REPLACEMENT PARTS MANUAL

WALL-MOUNTED VARIABLE CAPACITY ENVIRONMENTAL CONTROL UNITS

Models:

W5RV2-R W5LV2-R
W5RV2-S W5LV2-S
W5RV2-T W5LV2-T

Contents

Description	Page
Cabinet Components – Right (Extreme Duty Door)	
♦ Exploded View	2
♦ Usage List	3
Cabinet Components – Right (Moderate Duty Door)	
♦ Exploded View	4
♦ Usage List	5
Cabinet Components – Left (Extreme Duty Door)	
♦ Exploded View	6
♦ Usage List	7
Cabinet Components – Left (Moderate Duty Door)	
♦ Exploded View	8
♦ Usage List	9
Functional Components	
♦ Exploded View – Right Hand	10
♦ Exploded View – Left Hand	11
♦ Usage List – Right & Left Hand	12

Description	Page
Control Panel	
♦ Layout View – Right Hand	13
♦ Layout View – Left Left	14
♦ Usage List – Right & Left Hand	15
Blower Assembly	
♦ Exploded View	16
♦ Usage List	16

General Notes

- Revised and/or additional pages may be issued from time to time.
- A complete and current manual consists of pages shown in the following contents section.

Important

- Contact the installing and/or local Bard distributor for all parts requirements. Make sure to have the complete model and serial number available from the unit rating plates.



Climate Control Solutions

Bard Manufacturing Company, Inc.
Bryan, Ohio 43506
www.bardhvac.com

Manual: 2110-1417G
Supersedes: 2110-1417F
Date: 12-20-18

CABINET COMPONENTS - RIGHT (EXTREME DUTY DOOR)

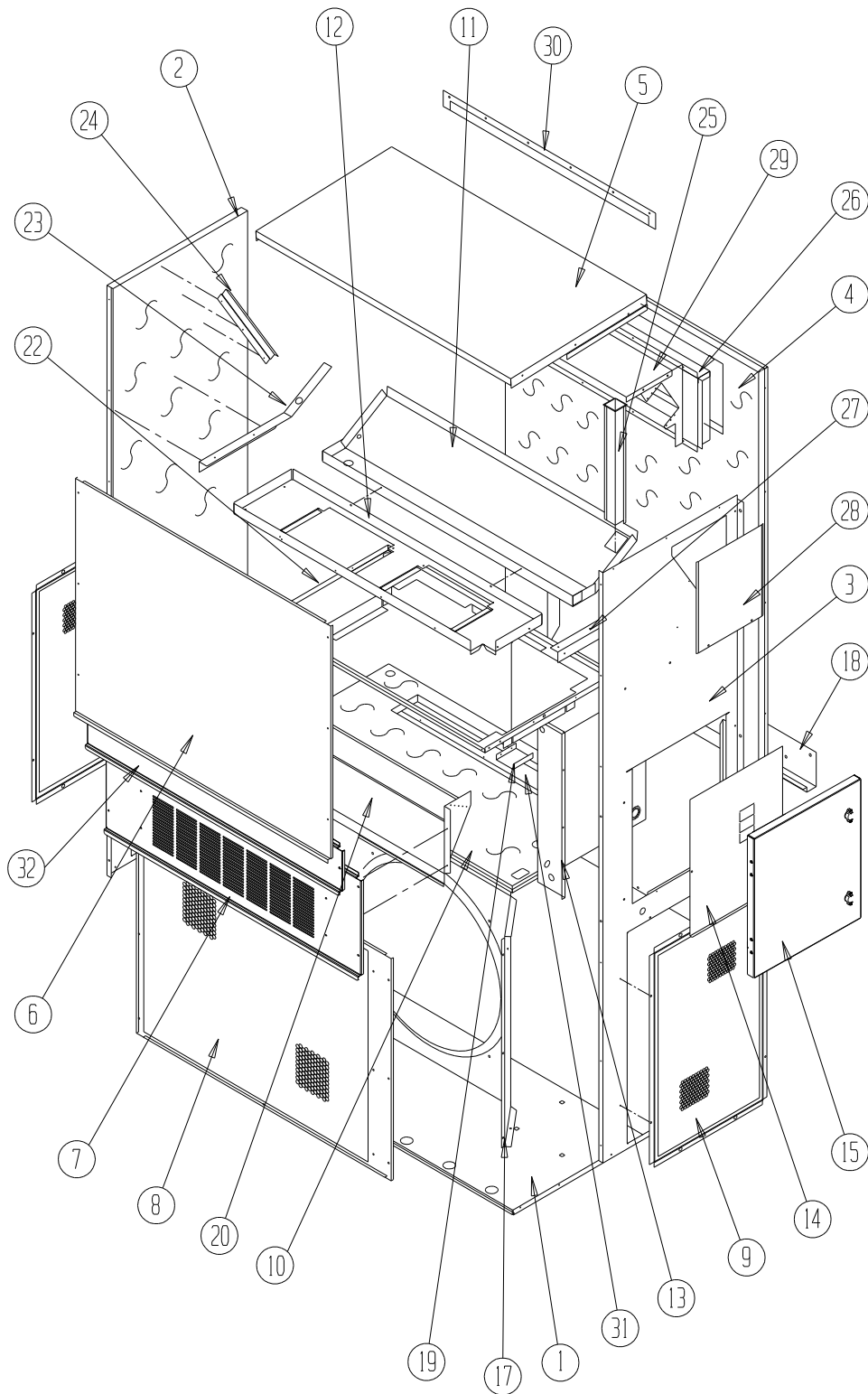

SEXP-734

CABINET COMPONENTS – RIGHT (EXTREME DUTY DOOR)

Drawing No.	Part No.	Description	W5RV2-R,S	W5RV2-T
1	S127-425	Lower Base	X	X
1	S127-430 ③	Lower Base	X	X
2	S501-686-* ①	Left Side	X	X
2	S501-699 ②	Left Side	X	X
2	S501-701 ③	Left Side	X	X
3	S501-853-* ①	Right Side	X	X
3	S501-855 ②	Right Side	X	X
3	S501-854 ③	Right Side	X	X
4	S508-098	Back	X	X
4	S508-275 ②	Back	X	X
4	S508-221 ③	Back	X	X
5	S507-307-* ①	Top	X	X
5	S507-309 ②	Top	X	X
5	S507-310 ③	Top	X	X
6	S515-230-* ①	Upper Front	X	X
6	S514-231 ②	Upper Front	X	X
6	S514-232 ③	Upper Front	X	X
7	S553-522-* ①	Vent Option Door	X	X
7	S552-525 ②	Vent Option Door	X	X
7	S553-527 ③	Vent Option Door	X	X
8	118-048-* ①	Condenser Grille	X	X
8	118-064 ②	Condenser Grille	X	X
8	118-072 ③	Condenser Grille	X	X
9	118-057-* ①	Side Grille	2	2
9	118-063 ②	Side Grille	2	2
9	118-073 ③	Side Grille	2	2
10	S521X462	Condenser Partition	X	X
11	S123-125 ③	Drain Pan	X	X
12	121X463	Blower Partition	X	X
13	Control Panel Assy.	See Control Panel Assy. Dwg. & Parts List	X	X
14	S132-114	Control Panel Cover (Inner)	X	
14	S132-183	Control Panel Cover (Inner)		X
15	DDD5A-* ①	Control Panel Cover (Outer)	X	X
15	DDD5A-S ④	Control Panel Cover (Outer)	X	X
17	125-024	Fan Shroud	X	X
17	125-058 ③	Fan Shroud	X	X
18	113-140	Bottom Mounting Bracket	X	X
19	137-209	Fill	X	X
20	BFAD-5	Fresh Air Damper Assembly	X	X
22	131X099	Filter Tray	X	X
23	105X877	Left Side Support	X	X
24	147-046	Left Evaporator Support	X	X
25	135-128	Raceway	X	X
26	S111X034	Outlet Air Frame Assembly	X	X
27	105X878	Right Side Support	X	X
28	S543-172-* ①	Heater Access Cover Assembly	X	X
28	S543-176 ②	Heater Access Cover Assembly	X	X
28	S543-177 ③	Heater Access Cover Assembly	X	X
29	135-129	Heat Shield	X	X
30	113-150-* ①	Top Rain Flashing	X	X
30	113-359 ③	Top Rain Flashing	X	X
31	S536X610	Condenser Partition Block-Off Plate	X	X
32	S553-521-* ①	Filter Door Assembly	X	X
32	S552-526 ②	Filter Door Assembly	X	X
32	S553-528 ③	Filter Door Assembly	X	X
NS	105-1302	Grommet Retainer	X	X

① Exterior cabinet parts are manufactured with various paint color options. To ensure the proper paint color is received, include the complete model and serial number of the unit for which cabinet parts are being ordered.

② Exterior cabinet parts are manufactured from aluminum Code "A"

③ Exterior cabinet parts are manufactured from stainless steel Code "S"

④ Exterior cabinet parts are used for both aluminum and stainless steel cabinets

NS – Not Shown

CABINET COMPONENTS - RIGHT (MODERATE DUTY DOOR)

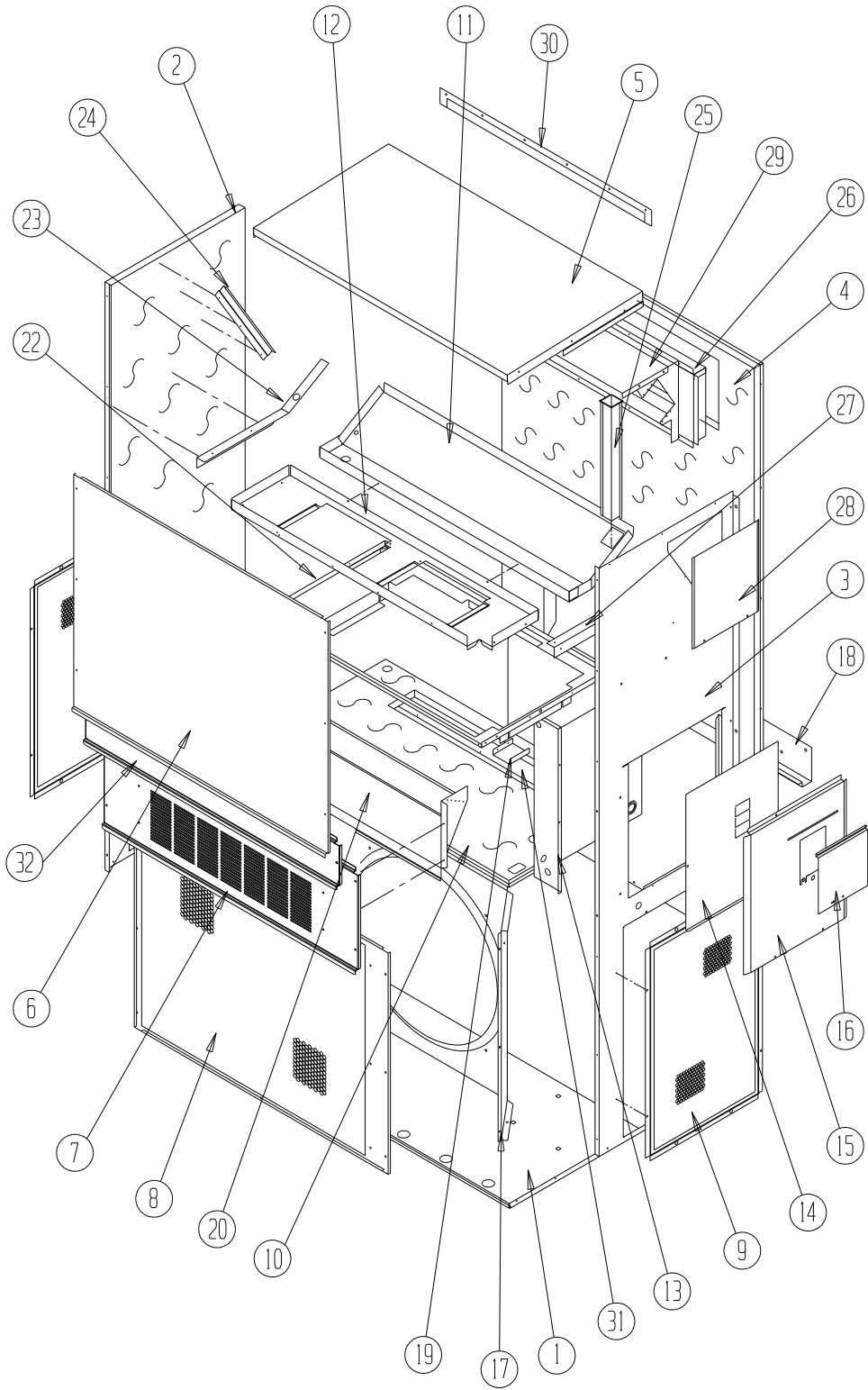

SEXP-735

CABINET COMPONENTS – RIGHT (MODERATE DUTY DOOR)

Drawing No.	Part No.	Description	W5RV2-R,S	W5RV2-T
1	S127-425	Lower Base	X	X
1	S127-430 ③	Lower Base	X	X
2	S501-686-* ①	Left Side	X	X
2	S501-699 ②	Left Side	X	X
2	S501-701 ③	Left Side	X	X
3	S501-677-* ①	Right Side	X	X
3	S501-698 ②	Right Side	X	X
3	S501-700 ③	Right Side	X	X
4	S508-098	Back	X	X
4	S508-275 ②	Back	X	X
4	S508-221 ③	Back	X	X
5	S507-307-* ①	Top	X	X
5	S507-309 ②	Top	X	X
5	S507-310 ③	Top	X	X
6	S515-230-* ①	Upper Front	X	X
6	S514-231 ②	Upper Front	X	X
6	S514-232 ③	Upper Front	X	X
7	S553-522-* ①	Vent Option Door	X	X
7	S552-525 ②	Vent Option Door	X	X
7	S553-527 ③	Vent Option Door	X	X
8	118-048-* ①	Condenser Grille	X	X
8	118-064 ②	Condenser Grille	X	X
8	118-072 ③	Condenser Grille	X	X
9	118-057-* ①	Side Grille	2	2
9	118-063 ②	Side Grille	2	2
9	118-073 ③	Side Grille	2	2
10	S521X462	Condenser Partition	X	X
11	S123-125	Drain Pan	X	X
12	121X463	Blower Partition	X	X
13	Control Panel Assy.	See Control Panel Assy. Dwg. & Parts List	X	X
14	S132-114	Control Panel Cover (Inner)	X	X
14	S132-183	Control Panel Cover (Inner)	X	X
15	S533-225-* ①	Control Panel Cover (Outer)	X	X
15	S533-229 ②	Control Panel Cover (Outer)	X	X
15	S533-230 ③	Control Panel Cover (Outer)	X	X
16	S153-218-* ①	Disconnect Access Door	X	X
16	S153-387 ②	Disconnect Access Door	X	X
16	S153-405 ③	Disconnect Access Door	X	X
17	125-024	Fan Shroud	X	X
17	125-058 ③	Fan Shroud	X	X
18	113-140	Bottom Mounting Bracket	X	X
19	137-209	Fill	X	X
20	BFAD-5	Fresh Air Damper Assembly	X	X
22	131X099	Filter Tray	X	X
23	105X877	Left Side Support	X	X
24	147-046	Left Evaporator Support	X	X
25	135-128	Raceway	X	X
26	S111X034	Outlet Air Frame Assembly	X	X
27	105X878	Right Side Support	X	X
28	S543-172-* ①	Heater Access Cover Assembly	X	X
28	S543-176 ②	Heater Access Cover Assembly	X	X
28	S543-177 ③	Heater Access Cover Assembly	X	X
29	135-129	Heat Shield	X	X
30	113-150-* ①	Top Rain Flashing	X	X
30	113-359 ③	Top Rain Flashing	X	X
31	S536X610	Condenser Partition Block-Off Plate	X	X
32	S553-521-* ①	Filter Door Assembly	X	X
32	S552-526 ②	Filter Door Assembly	X	X
32	S553-528 ③	Filter Door Assembly	X	X
NS	105-1302	Grommet Retainer	X	X

① Exterior cabinet parts are manufactured with various paint color options. To ensure the proper paint color is received, include the complete model and serial number of the unit for which cabinet parts are being ordered.

② Exterior cabinet parts are manufactured from aluminum Code "A"

③ Exterior cabinet parts are manufactured from stainless steel Code "S"

④ Exterior cabinet parts are used for both aluminum and stainless steel cabinets

NS – Not Shown

CABINET COMPONENTS - LEFT (EXTREME DUTY DOOR)

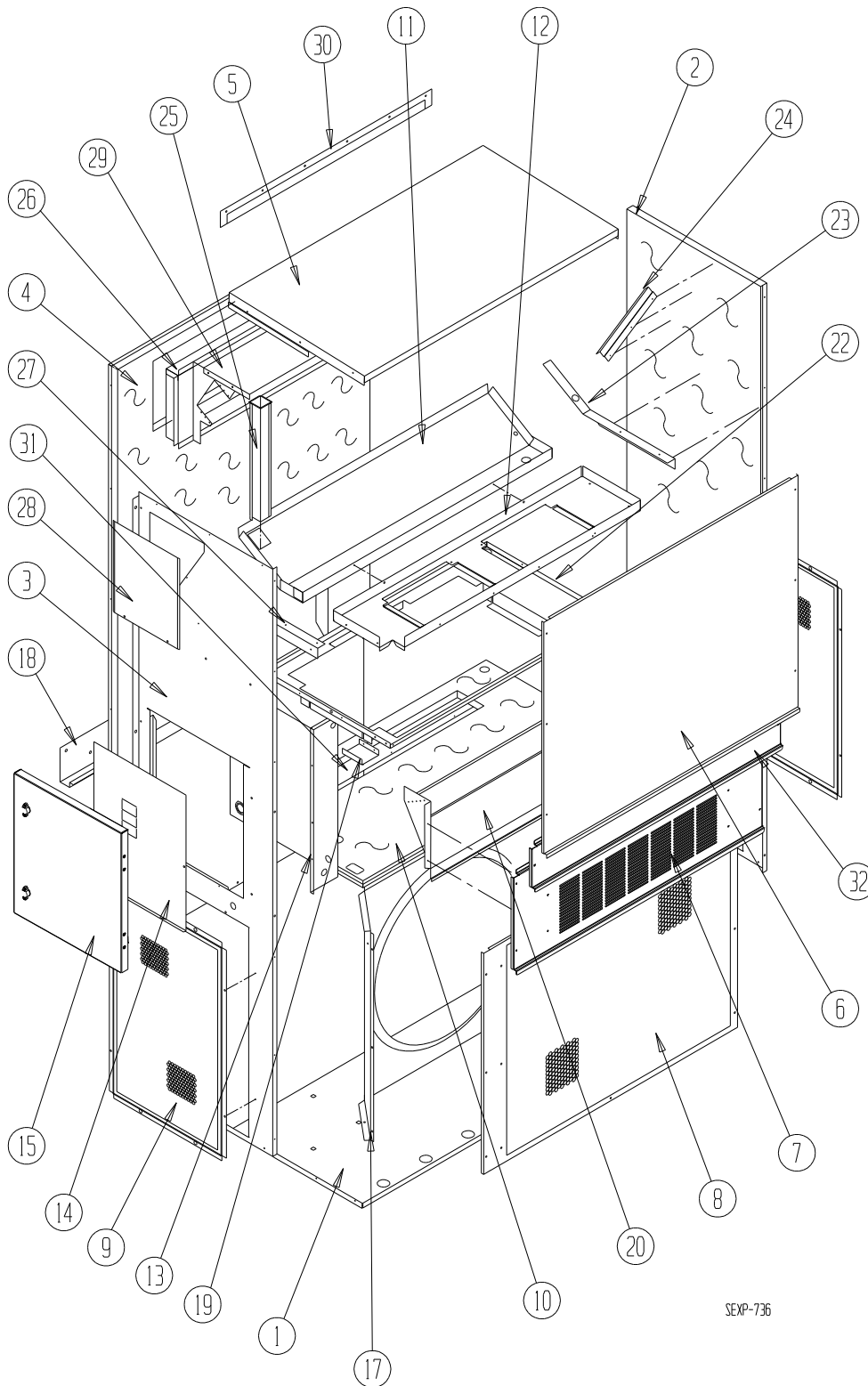

SEXP-736

CABINET COMPONENTS – LEFT (EXTREME DUTY DOOR)

Drawing No.	Part No.	Description	W51V2-R,S	W51V2-T
1	S127Y428	Lower Base	X	X
1	S127Y436 ③	Lower Base	X	X
2	S501-687-* ①	Right Side	X	X
2	S501-713 ②	Right Side	X	X
2	S501-715 ③	Right Side	X	X
3	S501-856-* ①	Left Side	X	X
3	S501-858 ②	Left Side	X	X
3	S501-857 ③	Left Side	X	X
4	S508-098	Back	X	X
4	S508-275 ②	Back	X	X
4	S508-221 ③	Back	X	X
5	S507-307-* ①	Top	X	X
5	S507-309 ②	Top	X	X
5	S507-310 ③	Top	X	X
6	S515-230-* ①	Upper Front	X	X
6	S514-231 ②	Upper Front	X	X
6	S514-232 ③	Upper Front	X	X
7	S553-522-* ①	Vent Option Door	X	X
7	S552-525 ②	Vent Option Door	X	X
7	S553-527 ③	Vent Option Door	X	X
8	118-049-* ①	Condenser Grille	X	X
8	118-065 ②	Condenser Grille	X	X
8	118-074 ③	Condenser Grille	X	X
9	118-057-* ①	Side Grille	2	2
9	118-063 ②	Side Grille	2	2
9	118-073 ③	Side Grille	2	2
10	S521Y462	Condenser Partition	X	X
11	123-125	Drain Pan	X	X
12	121Y463	Blower Partition	X	X
13	Control Panel Assembly	See Control Panel Assembly Drawing and Parts List	X	X
14	S133-114	Control Panel Cover (Inner)	X	
14	S133-306	Control Panel Cover (Inner)		X
15	DDD5L-* ①	Control Panel Cover (Outer)	X	X
15	DDD5L-S ④	Control Panel Cover (Outer)	X	X
17	125-024	Fan Shroud	X	X
17	125-058 ③	Fan Shroud	X	X
18	113-140	Bottom Mounting Bracket	X	X
19	137-209	Fill	X	X
20	BFAD-5	Fresh Air Damper Assembly	X	X
22	131Y099	Filter Tray	X	X
23	105Y878	Left Side Support	X	X
24	147-046	Left Evaporator Support	X	X
25	135-128	Raceway	2	2
26	S111Y034	Outlet Air Frame Assembly	X	X
27	105Y877	Right Side Support	X	X
28	S543-172-* ①	Heater Access Cover Assembly	X	X
28	S543-176 ②	Heater Access Cover Assembly	X	X
28	S543-177 ③	Heater Access Cover Assembly	X	X
29	135-129	Heat Shield	X	X
30	113-150-* ①	Top Rain Flashing	X	X
30	113-359 ③	Top Rain Flashing	X	X
31	S536Y610	Condenser Partition Block-Off Plate	X	X
32	S553-521-* ①	Filter Door Assembly	X	X
32	S552-526 ②	Filter Door Assembly	X	X
32	S553-528 ③	Filter Door Assembly	X	X
NS	105-1302	Grommet Retainer	X	X

① Exterior cabinet parts are manufactured with various paint color options. To ensure the proper paint color is received, include the complete model and serial number of the unit for which cabinet parts are being ordered.

② Exterior cabinet parts are manufactured from aluminum Code "A"

③ Exterior cabinet parts are manufactured from stainless steel Code "S"

④ Exterior cabinet parts are used for both aluminum and stainless steel cabinets

NS – Not Shown

CABINET COMPONENTS - LEFT (MODERATE DUTY DOOR)

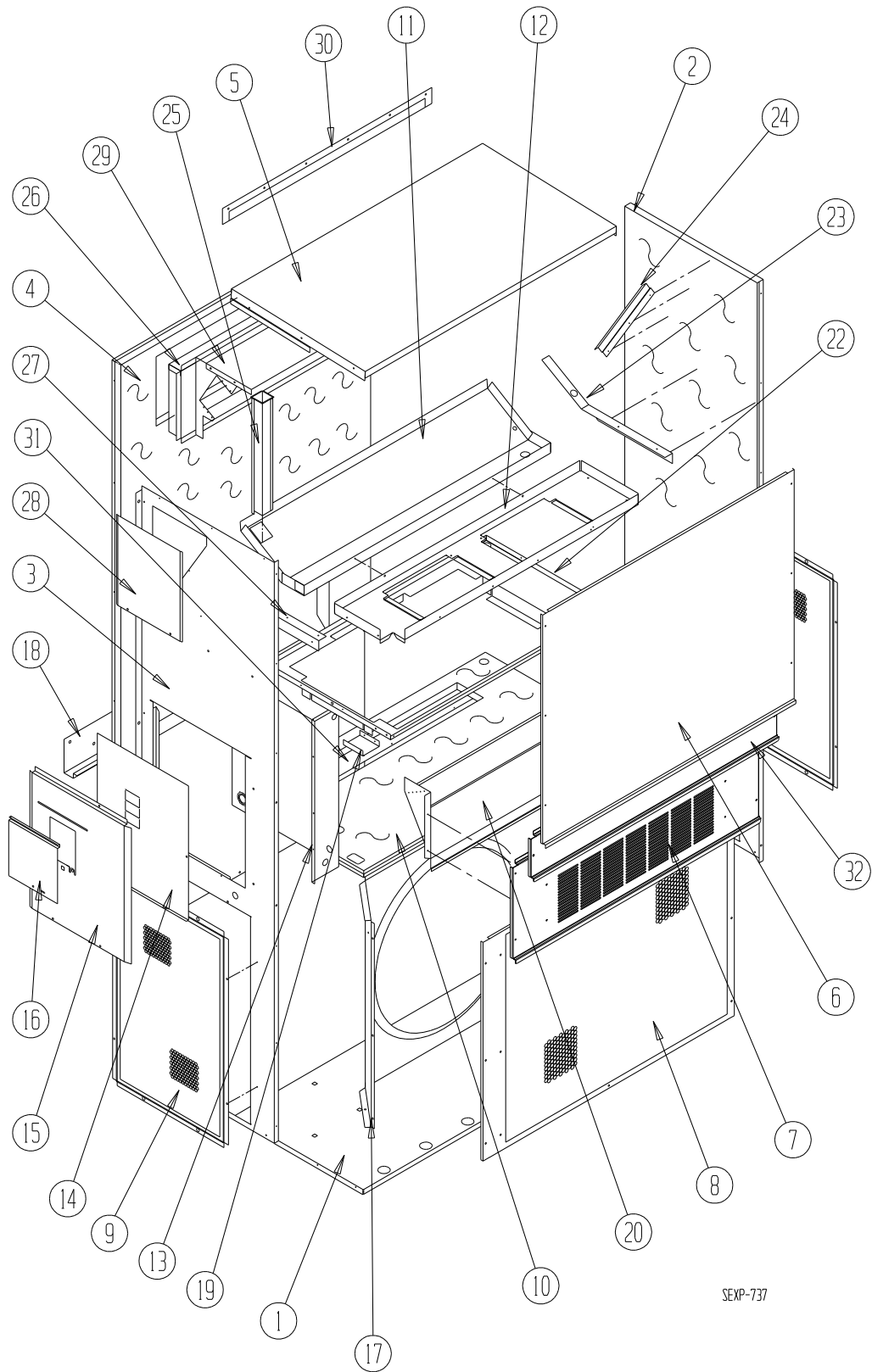

SEXP-737

CABINET COMPONENTS – LEFT (MODERATE DUTY DOOR)

Drawing No.	Part No.	Description	W5LV2-R,S	W5LV2-T
1	S127Y428	Lower Base	X	X
1	S127Y430 ③	Lower Base	X	X
2	S501-687-* ①	Right Side	X	X
2	S501-713 ②	Right Side	X	X
2	S501-715 ③	Right Side	X	X
3	S501-680-* ①	Left Side	X	X
3	S501-714 ②	Left Side	X	X
3	S501-716 ③	Left Side	X	X
4	S508-098	Back	X	X
4	S508-275 ②	Back	X	X
4	S508-221 ③	Back	X	X
5	S507-307-* ①	Top	X	X
5	S507-309 ②	Top	X	X
5	S507-310 ③	Top	X	X
6	S515-230-* ①	Upper Front	X	X
6	S514-231 ②	Upper Front	X	X
6	S514-232 ③	Upper Front	X	X
7	S553-522-* ①	Vent Option Door	X	X
7	S552-525 ②	Vent Option Door	X	X
7	S553-527 ③	Vent Option Door	X	X
8	118-049-* ①	Condenser Grille	X	X
8	118-065 ②	Condenser Grille	X	X
8	118-074 ③	Condenser Grille	X	X
9	118-057-* ①	Side Grille	2	2
9	118-063 ②	Side Grille	2	2
9	118-073 ③	Side Grille	2	2
10	S521Y462	Condenser Partition	X	X
11	123-125	Drain Pan	X	X
12	121Y463	Blower Partition	X	X
13	Control Panel Assembly	See Control Panel Assembly Drawing and Parts List	X	X
14	S133-114	Control Panel Cover (Inner)	X	
14	S133-306	Control Panel Cover (Inner)		X
15	S533-227-* ①	Control Panel Cover (Outer)	X	X
15	S533-231 ②	Control Panel Cover (Outer)	X	X
15	S533-233 ③	Control Panel Cover (Outer)	X	X
16	S153-218-* ①	Disconnect Access Door	X	X
16	S153-387 ②	Disconnect Access Door	X	X
16	S153-405 ③	Disconnect Access Door	X	X
17	125-024	Fan Shroud	X	X
17	125-058 ③	Fan Shroud	X	X
18	113-140	Bottom Mounting Bracket	X	X
19	137-209	Fill	X	X
20	BFAD-5	Fresh Air Damper Assembly	X	X
22	131Y099	Filter Tray	X	X
23	105Y878	Left Side Support	X	X
24	147-046	Left Evaporator Support	X	X
25	135-128	Raceway	2	2
26	S111Y034	Outlet Air Frame Assembly	X	X
27	105Y877	Right Side Support	X	X
28	S543-172-* ①	Heater Access Cover Assembly	X	X
28	S543-176 ②	Heater Access Cover Assembly	X	X
28	S543-177 ③	Heater Access Cover Assembly	X	X
29	135-129	Heat Shield	X	X
30	113-150-* ①	Top Rain Flashing	X	X
30	113-359 ③	Top Rain Flashing	X	X
31	S536Y610	Condenser Partition Block-Off Plate	X	X
32	S553-521-* ①	Filter Door Assembly	X	X
32	S552-526 ②	Filter Door Assembly	X	X
32	S553-528 ③	Filter Door Assembly	X	X
NS	105-1302	Grommet Retainer	X	X

① Exterior cabinet parts are manufactured with various paint color options. To ensure the proper paint color is received, include the complete model and serial number of the unit for which cabinet parts are being ordered.

② Exterior cabinet parts are manufactured from aluminum Code "A"

③ Exterior cabinet parts are manufactured from stainless steel Code "S"

④ Exterior cabinet parts are used for both aluminum and stainless steel cabinets

NS – Not Shown

FUNCTIONAL COMPONENTS - RIGHT HAND

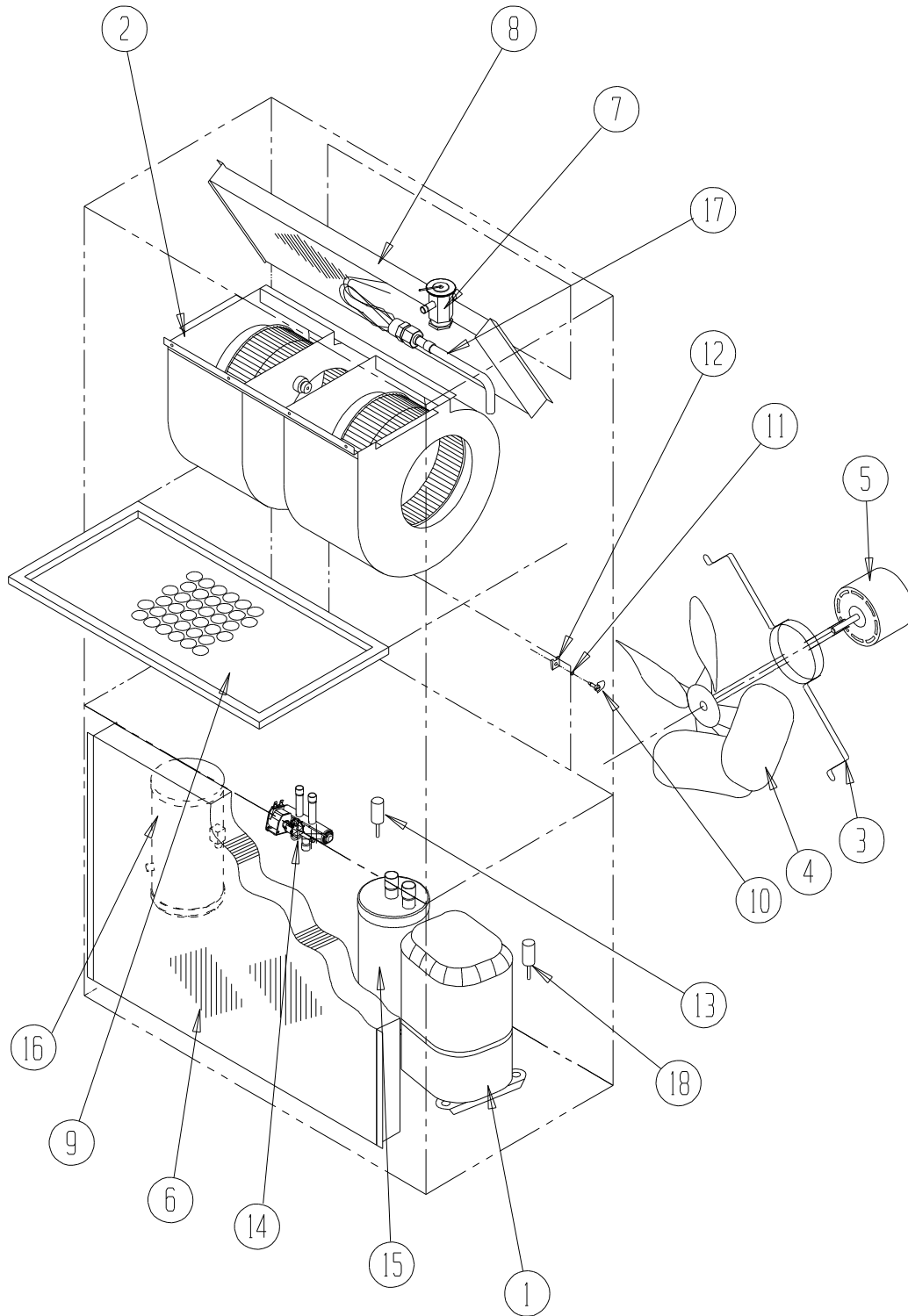

SEXP-589

This exploded view references table on page 12

FUNCTIONAL COMPONENTS - LEFT HAND

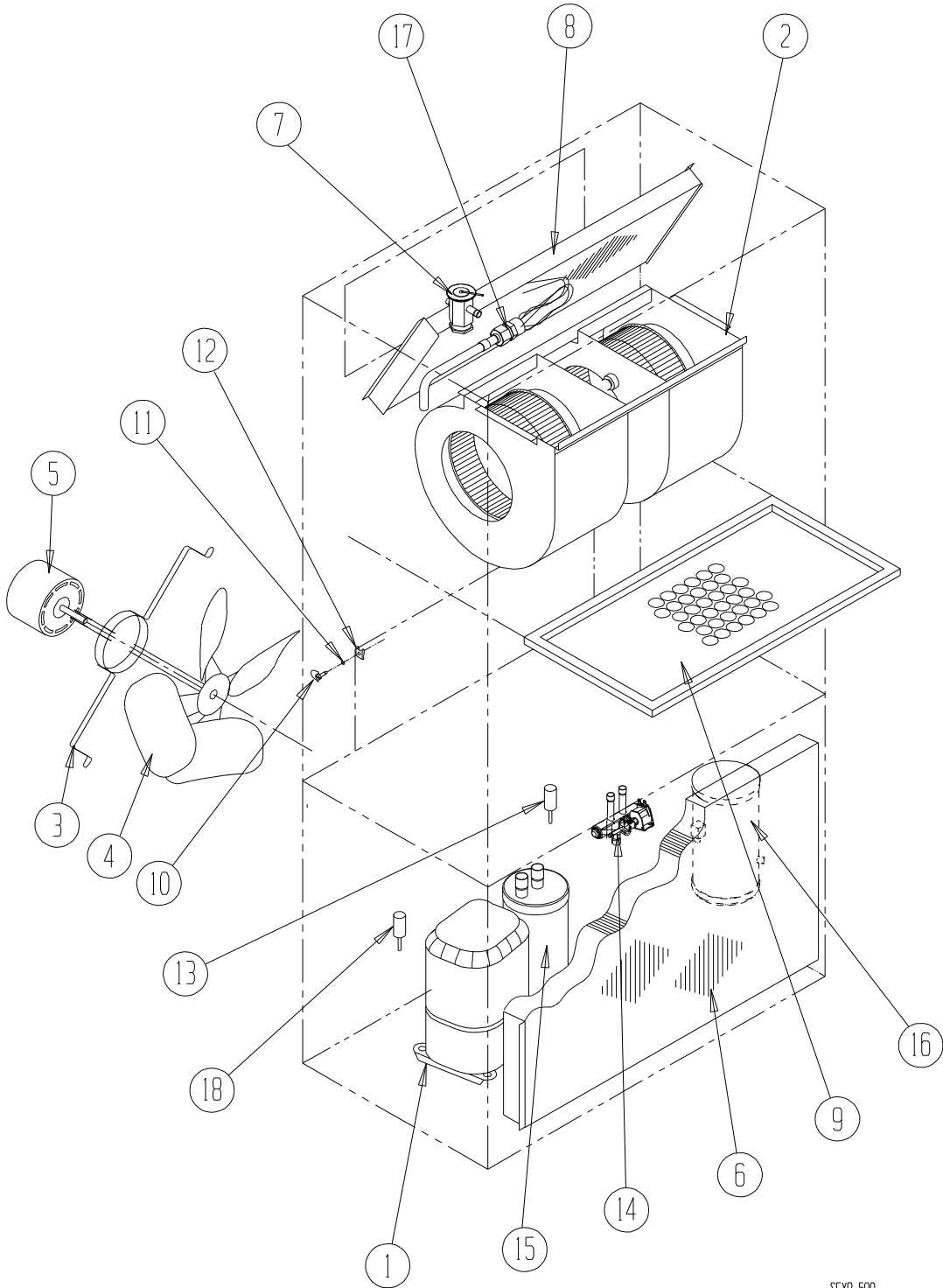

SEXP-590

This exploded view references table on page 12

FUNCTIONAL COMPONENTS – RIGHT & LEFT HAND

Drawing No.	Part No.	Description	W5RV2-R	W5RV2-S	W5RV2-T	W5LV2-R	W5LV2-S	W5LV2-T
1	8000-352	Compressor	X			X		
1	8000-360	Compressor		X			X	
1	8000-361	Compressor			X			X
2	S900-340-001	Blower Assembly	X	X		X	X	
2	S900-341-001	Blower Assembly			X			X
3	8200-004	Fan Motor Mount	X	X	X	X	X	X
4	5151-060	Fan Blade	X	X	X	X	X	X
5	S8106-061-0132	1/2 HP ECM Motor with Programmed Control	X	X		X	X	
5	S8106-058-0133	1/2 HP ECM Motor with Programmed Control			X			X
6	5051-083BX	Condenser Coil	X	X	X			
6	5051-153BX	Condenser Coil				X	X	X
7	5651-215	Cooling TXV	X	X	X	X	X	X
8	5060-082BX	Evaporator Coil	X	X	X	X	X	X
9	7004-016	Air Filter 1" Throw-Away	X	X	X	X	X	X
9	7003-030	Air Filter 1" Washable ①	X	X	X	X	X	X
9	7004-027	Air Filter 2" Pleated ①	X	X	X	X	X	X
10	1171-022	1/4 Turn Fastener	X	X	X	X	X	X
11	1171-024	1/4 Turn Retainer	X	X	X	X	X	X
12	1171-023	1/4 Turn Receptacle	X	X	X	X	X	X
13	1804-0462	High Pressure Switch (Flare) - Red Leads	X	X	X	X	X	X
14	5650-049	Solenoid Valve	X	X	X	X	X	X
15	5202-018	Accumulator	X	X	X	X	X	X
16	5203-006	Receiver	X	X	X	X	X	X
17	800-0395	Cooling Distributor Assembly	X	X	X	X	X	X
18	1804-0107	Low Pressure Switch (Flare) - Blue Leads	X	X	X	X	X	X
NS	5201-002	Filter Drier	X	X	X	X	X	X
NS	8605-017	Crankcase Heater	X	X		X	X	
NS	8605-018	Crankcase Heate			X			X
NS	8408-039	Discharge Line Thermostat	X	X	X	X	X	X
NS	8406-128	Pressure Transducer	X	X	X	X	X	X
NS	5451-024	Tubing Grommet	2	2	2	2	2	2

NS – Not Shown

① – Optional

This table references exploded views on pages 10 & 11

CONTROL PANEL - RIGHT HAND

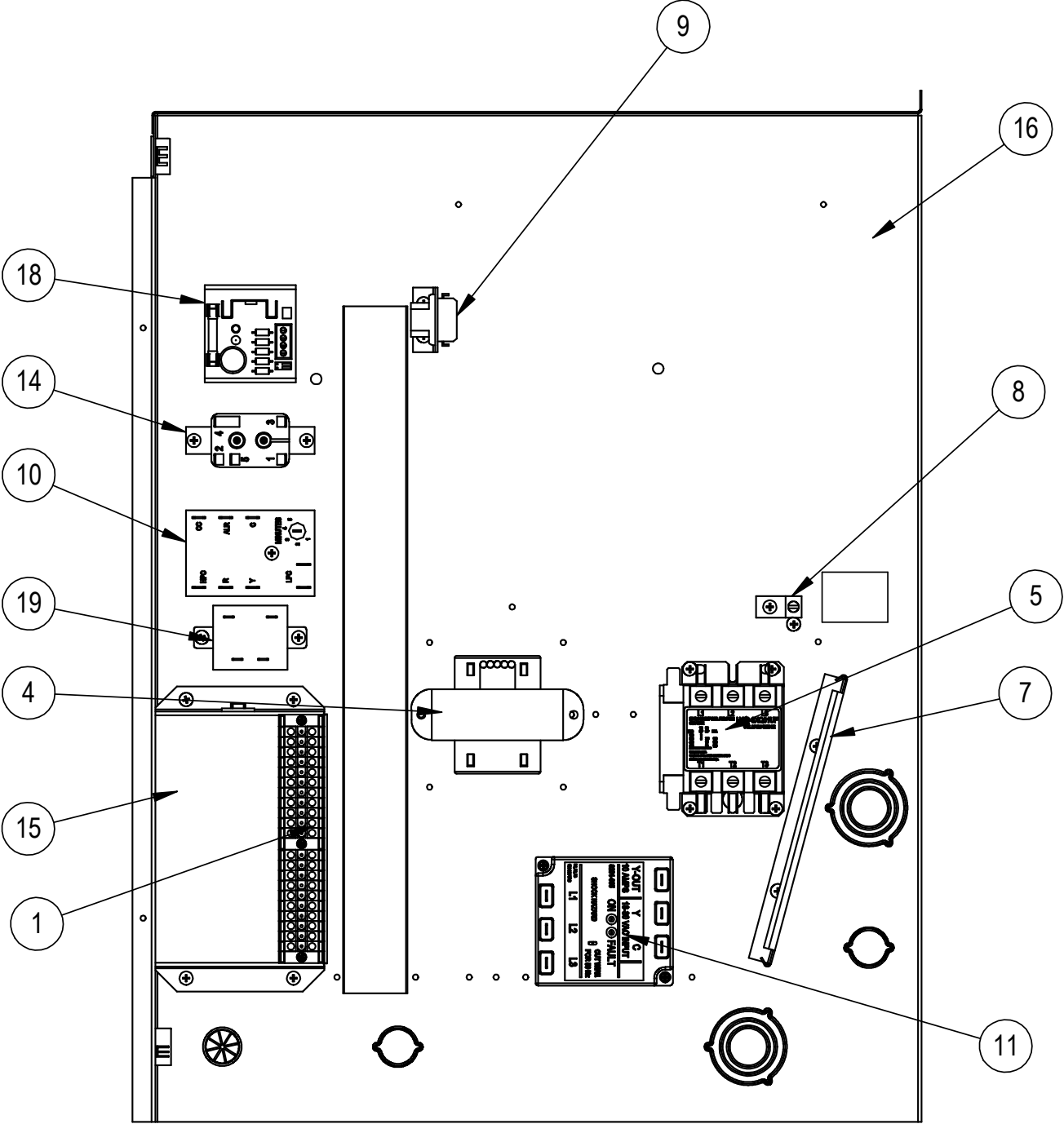

SEXP-738 A

This exploded view references table on page 15

CONTROL PANEL - LEFT HAND

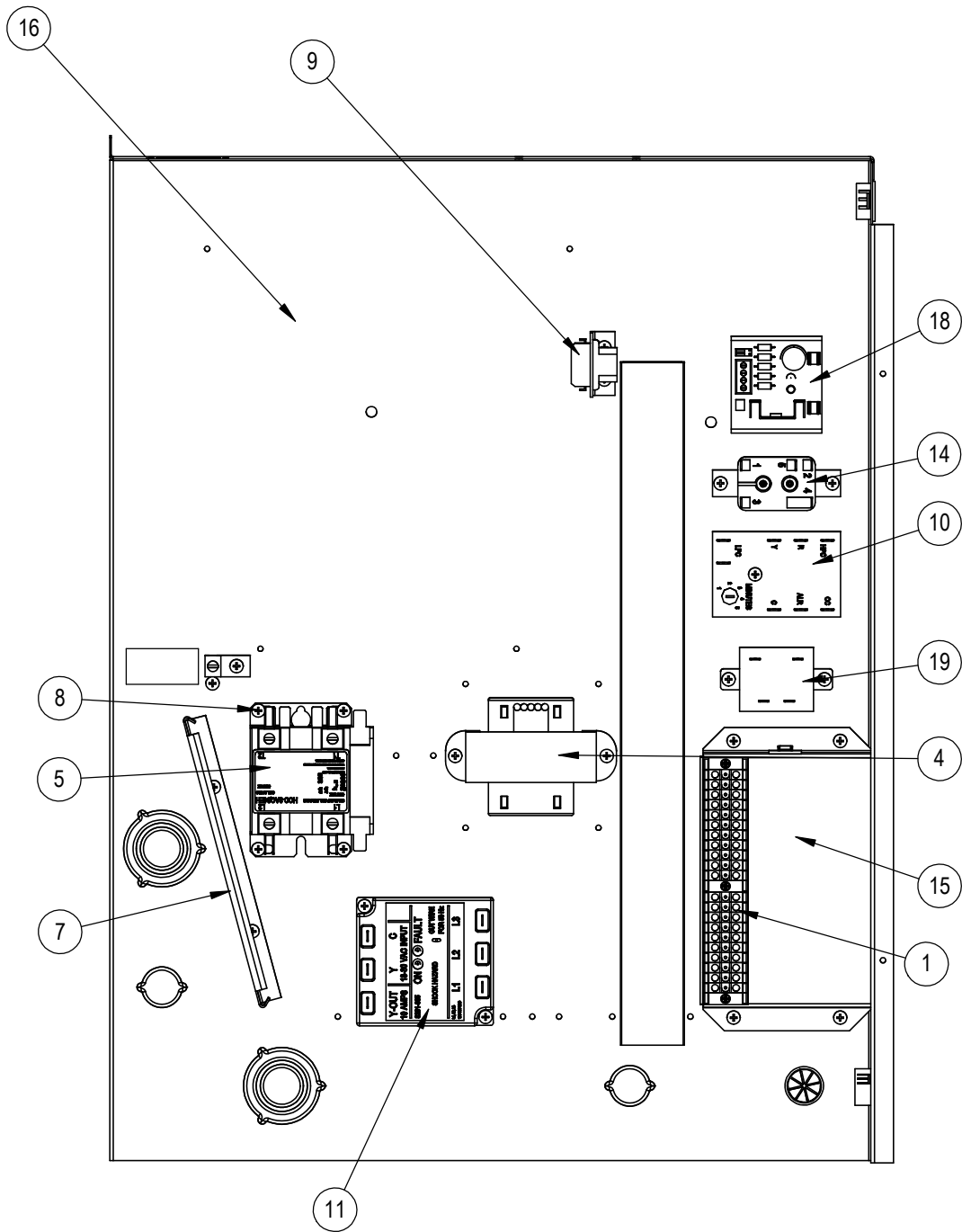

SEXP-739 A

This exploded view references table on page 15

CONTROL PANEL – RIGHT & LEFT HAND

Drawing No.	Part No.	Description	W5RV2-R	W5RV2-S	W5RV2-T	W5LV2-R	W5LV2-S	W5LV2-T
1	8607-036	Low Voltage Terminal Strip	X	X	X	X	X	X
4	8407-071	Transformer	X	X		X	X	
4	8407-072	Transformer			X			X
5	8401-038	Compressor Contactor	X			X		
5	8401-037	Compressor Contactor		X	X		X	X
7	135-130	Wire Shield	X	X	X	X	X	X
8	8611-006	Ground Terminal	X	X	X	X	X	X
9	3000-1463	6 Pin Connector	X	X	X	X	X	X
10	8201-148	Compressor Control Module	X	X	X	X	X	X
11	8201-126	Phase Monitor		X	X		X	X
14	8201-062	Alarm Relay	X	X	X	X	X	X
15	S117-350	Low Voltage Box	X	X	X	X	X	X
16	117X351	Control Panel	X	X	X			
16	117Y351	Control Panel				X	X	X
18	8301-041	5VDC Supply	X	X	X	X	X	X
19	8201-149	Solid State Relay	X	X	X	X	X	X
NS	8552-092	Compressor Capacitor	X			X		
NS	8551-004	Motor Starting Device	X			X		
NS	8301-014	Outdoor Air Sensor	X	X	X	X	X	X
NS	8403-066	Thermostat Controller	X	X	X	X	X	X
NS	8615-041	Circuit Breaker 60A 2 Pole (Opt) ①	X			X		
NS	8615-043	Circuit Breaker 40A 3 Pole (Opt) ①		X			X	
NS	8615-068	Toggle Disconnect (Optional)			X			X
NS	3000-1360	Pressure Transducer Harness	X	X	X	X	X	X
NS	3000-1224	Compressor Harness	X			X		
NS	3000-1231	Compressor Harness		X	X		X	X
NS	4095-175	Wiring Diagram	X			X		
NS	4095-275	Wiring Diagram		X			X	
NS	4095-375	Wiring Diagram			X			X

NS – Not Shown

- ① Circuit breakers listed are for units without electric heat "OZ" models.
See heater replacement parts manual for units with electric heat.

This table references exploded views on pages 13 & 14

BLOWER ASSEMBLY

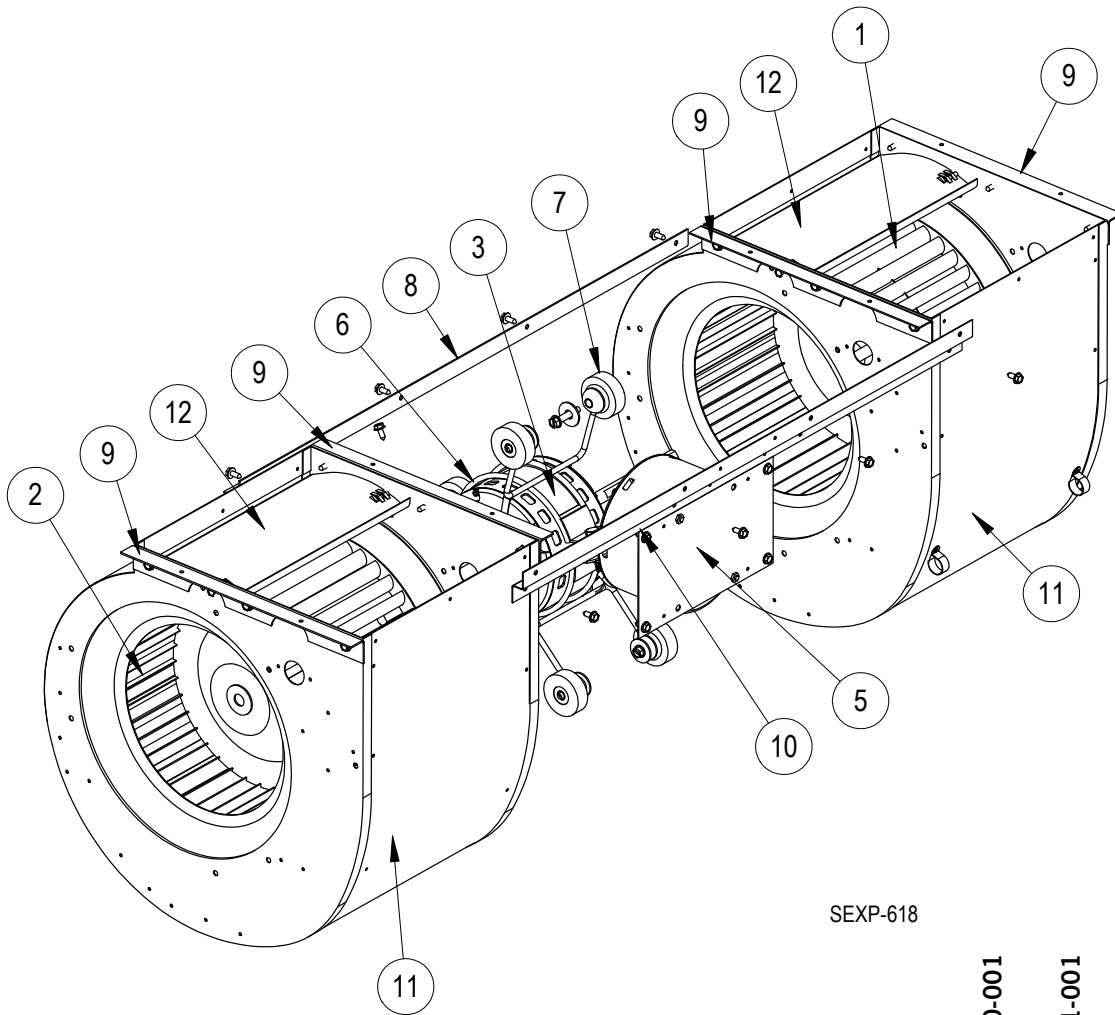

SEXP-618

Drawing No.	Part No.	Description	900-340-001	900-341-001
1	5152-011	Wheel (CW)	X	X
2	5152-012	Wheel (CCW)	X	X
3	S8107-023-0130	Programmed Motor w/Control	X	
3	S8107-024-0131	Programmed Motor w/Control		X
5	112-344	Blower Motor Control Mount	X	X
6	8200-040	Motor Mount	X	X
7	5451-011	Grommets	6	6
8	105-881	Back Brace	X	X
9	105-880	Blower Angle	4	4
10	103-389	Front Brace	X	X
11	151-101	Blower Housing	2	2
12	144-166	Diffuser	2	2