REPLACEMENT PARTS MANUAL

WALL MOUNTED PACKAGE AIR CONDITIONER

Models:

W42LA-A W48LA-A W60LA-A W72LA-A
W42LA-B W48LA-B W60LA-B W72LA-B
W42LA-C W48LA-C W60LA-C W72LA-C
W42LA-F W48LA-F W60LA-F W72LA-F

General Notes

- Revised and/or additional pages may be issued from time to time.
- A complete and current manual consists of pages shown in the following contents section.

Important

- Contact the installing and/or local Bard distributor for all parts requirements. Make sure to have the complete model and serial number available from the unit rating plates.

Contents

<u>Description</u>	<u>Page</u>
Cabinet Components	
♦ Exploded View	2
♦ Usage List	3
♦ Usage List	4
Functional Components	
♦ Exploded View	5
♦ Usage List	6
♦ Usage List	7
Control Panel	
♦ Layout View	8
♦ Usage List	9
♦ Usage List	10
Blower Assembly	
♦ Exploded View	11
♦ Usage List	11
♦ Exploded View	12
♦ Usage List	12



Bard Manufacturing Company, Inc.
Bryan, Ohio 43506
www.bardvac.com

Manual: 2110-1424D
Supersedes: 2110-1424C
Date: 2-8-18

CABINET COMPONENTS

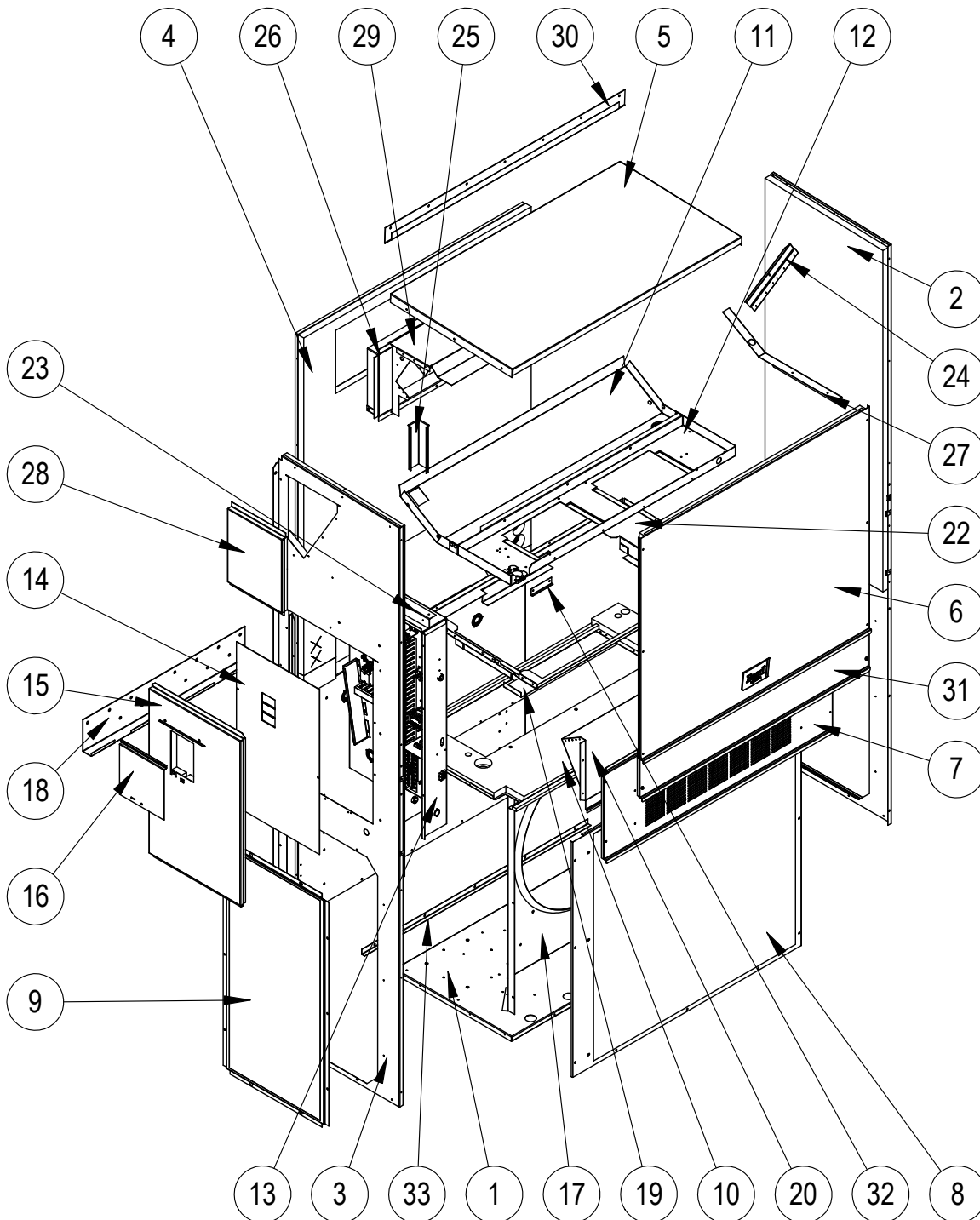

SEXP-788

This drawing is referenced in tables on pages 3 and 4

CABINET COMPONENTS

Dwg No.	Part Number	Description	W42LA-A, B	W42LA-C, F	W48LA-A, B	W48LA-C, F
1	S127-428	Lower Base	X	X	X	X
1	S127-543 ③	Lower Base	X	X	X	X
2	S501-687-* ①	Right Side	X	X	X	X
2	S501-713 ②	Right Side	X	X	X	X
2	S501-1007 ③	Right Side	X	X	X	X
3	S501-842-* ①	Left Side	X	X	X	X
3	S501-927 ②	Left Side	X	X	X	X
3	S501-1008 ③	Left Side	X	X	X	X
4	S508-098	Back	X	X	X	X
4	S508-275 ②	Back	X	X	X	X
4	S508-395 ③	Back	X	X	X	X
5	S507-307-* ①	Top	X	X	X	X
5	S507-309 ②	Top	X	X	X	X
5	S507-310 ③	Top	X	X	X	X
6	S515-230-* ①	Upper Front	X	X	X	X
6	S514-231 ②	Upper Front	X	X	X	X
6	S514-232 ③	Upper Front	X	X	X	X
7	S553-522-* ①	Vent Option Door	X	X	X	X
7	S553-525 ②	Vent Option Door	X	X	X	X
7	S553-527 ③	Vent Option Door	X	X	X	X
8	118-049-* ①	Condenser Grille	X	X	X	X
8	118-065 ②	Condenser Grille	X	X	X	X
8	118-074 ③	Condenser Grille	X	X	X	X
9	118-057-* ①	Side Grille	2	2	2	2
9	118-063 ②	Side Grille	2	2	2	2
9	118-073 ③	Side Grille	2	2	2	2
10	S521Y503	Condenser Partition	X	X	X	X
10	S521-563 ③	Condenser Partition	X	X	X	X
11	S123-121	Drain Pan	X	X	X	X
11	S123-137 ②③	Drain Pan	X	X	X	X
12	121Y463	Blower Partition	X	X	X	X
13	Control Panel Assy.	See Control Panel Assy. Drawing & Parts List	X	X	X	X
14	S133-277	Control Panel Cover (Inner)	X		X	
14	S133-278	Control Panel Cover (Inner)		X		X
15	S533-280-* ①	Control Panel Cover (Outer)	X	X	X	X
15	S533-273 ②	Control Panel Cover (Outer)	X	X	X	X
15	S533-274 ③	Control Panel Cover (Outer)	X	X	X	X
16	S153-218-* ①	Disconnect Access Door	X	X	X	X
16	S153-387 ②	Disconnect Access Door	X	X	X	X
16	S153-405 ③	Disconnect Access Door	X	X	X	X
17	125-024	Fan Shroud	X	X	X	X
17	125-058 ③	Fan Shroud	X	X	X	X
18	113-140	Bottom Mounting Bracket	X	X	X	X
19	137-209	Fill	X	X	X	X
20	BFAD-5	Fresh Air Damper Assembly	X	X	X	X
22	131Y099	Filter Tray	X	X	X	X
23	105Y878	Left Side Support	X	X	X	X
24	147-046	Left Evaporator Support	X	X	X	X
25	135-377	Raceway	2	2	2	2
26	S111Y034	Outlet Air Frame Assembly	X	X	X	X
27	105Y877	Right Side Support	X	X	X	X
28	S543-172-* ①	Right Side Cover Plate (Outer)	X	X	X	X
28	S543-176 ②	Right Side Cover Plate (Outer)	X	X	X	X
28	S543-177 ③	Right Side Cover Plate (Outer)	X	X	X	X
29	135-129	Heat Shield	X	X	X	X
30	113-150-* ①	Top Rain Flashing	X	X	X	X
30	113-359 ③	Top Rain Flashing	X	X	X	X
31	S553-521-* ①	Filter Door Assembly	X	X	X	X
31	S553-526 ②	Filter Door Assembly	X	X	X	X
31	S553-528 ③	Filter Door Assembly	X	X	X	X
32	105-1302	Grommet Retainer	X	X	X	X
33	105-1324	Close Off Angle	X	X	X	X
NS	S536-804	Cond. Partition Block Off Plate	X	X	X	X
NS	S536-881 ③	Cond. Partition Block Off Plate	X	X	X	X

① Exterior cabinet parts are manufactured with various paint color options. To ensure the proper paint color is received, include the complete model and serial number of the unit for which cabinet parts are being ordered.

② Exterior cabinet parts are manufactured from aluminum Code "A"

NS – Not Shown

③ Exterior cabinet parts are manufactured from stainless steel Code "S"

CABINET COMPONENTS

Dwg No.	Part Number	Description	W60LA-A, B	W60LA-C, F	W72LA-A, B	W72LA-C, F
1	127-428	Lower Base	X	X	X	X
1	127-543 ③	Lower Base	X	X	X	X
2	S501-912-* ①	Right Side	X	X	X	X
2	S501-932 ②	Right Side	X	X	X	X
2	S501-1011 ③	Right Side	X	X	X	X
3	S501-843-* ①	Left Side	X	X	X	X
3	S501-930 ②	Left Side	X	X	X	X
3	S501-1012 ③	Left Side	X	X	X	X
4	S508-251	Back	X	X	X	X
4	S508-252 ②	Back	X	X	X	X
4	S508-396 ③	Back	X	X	X	X
5	S507-307-* ①	Top	X	X	X	X
5	S507-309 ②	Top	X	X	X	X
5	S507-310 ③	Top	X	X	X	X
6	S515-246-* ①	Upper Front	X	X	X	X
6	S514-280 ②	Upper Front	X	X	X	X
6	S514-253 ③	Upper Front	X	X	X	X
7	S553-522-* ①	Vent Option Door	X	X	X	X
7	S553-525 ②	Vent Option Door	X	X	X	X
7	S553-527 ③	Vent Option Door	X	X	X	X
8	118-094-* ①	Condenser Grille	X	X	X	X
8	118-100 ②	Condenser Grille	X	X	X	X
8	118-099 ③	Condenser Grille	X	X	X	X
9	118-086-* ①	Side Grille	2	2	2	2
9	118-088 ②	Side Grille	2	2	2	2
9	118-090 ③	Side Grille	2	2	2	2
10	S521Y503	Condenser Partition	X	X	X	X
10	S521-563 ③	Condenser Partition	X	X	X	X
11	S123-121	Drain Pan	X	X	X	X
11	S123-137 ②③	Drain Pan	X	X	X	X
12	121Y463	Blower Partition	X	X	X	X
13	Control Panel Assy.	See Control Panel Assy. Drawing & Parts List	X	X	X	X
14	S133-277	Control Panel Cover (Inner)	X		X	
14	S133-278	Control Panel Cover (Inner)		X		X
15	S533-280-* ①	Control Panel Cover (Outer)	X	X	X	X
15	S533-273 ②	Control Panel Cover (Outer)	X	X	X	X
15	S533-274 ③	Control Panel Cover (Outer)	X	X	X	X
16	S153-218-* ①	Disconnect Access Door	X	X	X	X
16	S153-387 ②	Disconnect Access Door	X	X	X	X
16	S153-405 ③	Disconnect Access Door	X	X	X	X
17	125-070	Fan Shroud	X	X		
17	125-079 ③	Fan Shroud	X	X	X	X
17	125-084	Fan Shroud			X	X
18	113-140	Bottom Mounting Bracket	X	X	X	X
19	137-209	Fill	X	X	X	X
20	BFAD-5	Fresh Air Damper Assembly	X	X	X	X
22	131Y099	Filter Tray	X	X	X	X
23	105Y878	Left Side Support	X	X	X	X
24	147-046	Left Evaporator Support	X	X	X	X
25	135-377	Raceway	2	2	2	2
26	S111Y034	Outlet Air Frame Assembly	X	X	X	X
27	105Y877	Right Side Support	X	X	X	X
28	S543-172-* ①	Right Side Cover Plate (Outer)	X	X	X	X
28	S543-176 ②	Right Side Cover Plate (Outer)	X	X	X	X
28	S543-177 ③	Right Side Cover Plate (Outer)	X	X	X	X
29	135-129	Heat Shield	X	X	X	X
30	113-150-* ①	Top Rain Flashing	X	X	X	X
30	113-359 ③	Top Rain Flashing	X	X	X	X
31	S553-521-* ①	Filter Door Assembly	X	X	X	X
31	S553-526 ②	Filter Door Assembly	X	X	X	X
31	S553-528 ③	Filter Door Assembly	X	X	X	X
32	105-1302	Grommet Retainer	X	X	X	X
33	105-1324	Close Off Angle	X	X	X	X
NS	S536-804	Cond. Partition Block Off Plate	X	X	X	X
NS	S536-881 ③	Cond. Partition Block Off Plate	X	X	X	X

① Exterior cabinet parts are manufactured with various paint color options. To insure the proper paint color is received, include the complete model and serial number of the unit for which cabinet parts are being ordered.

② Exterior cabinet parts are manufactured from aluminum Code "A"

③ Exterior cabinet parts are manufactured from stainless steel Code "S"

NS – Not Shown

FUNCTIONAL COMPONENTS

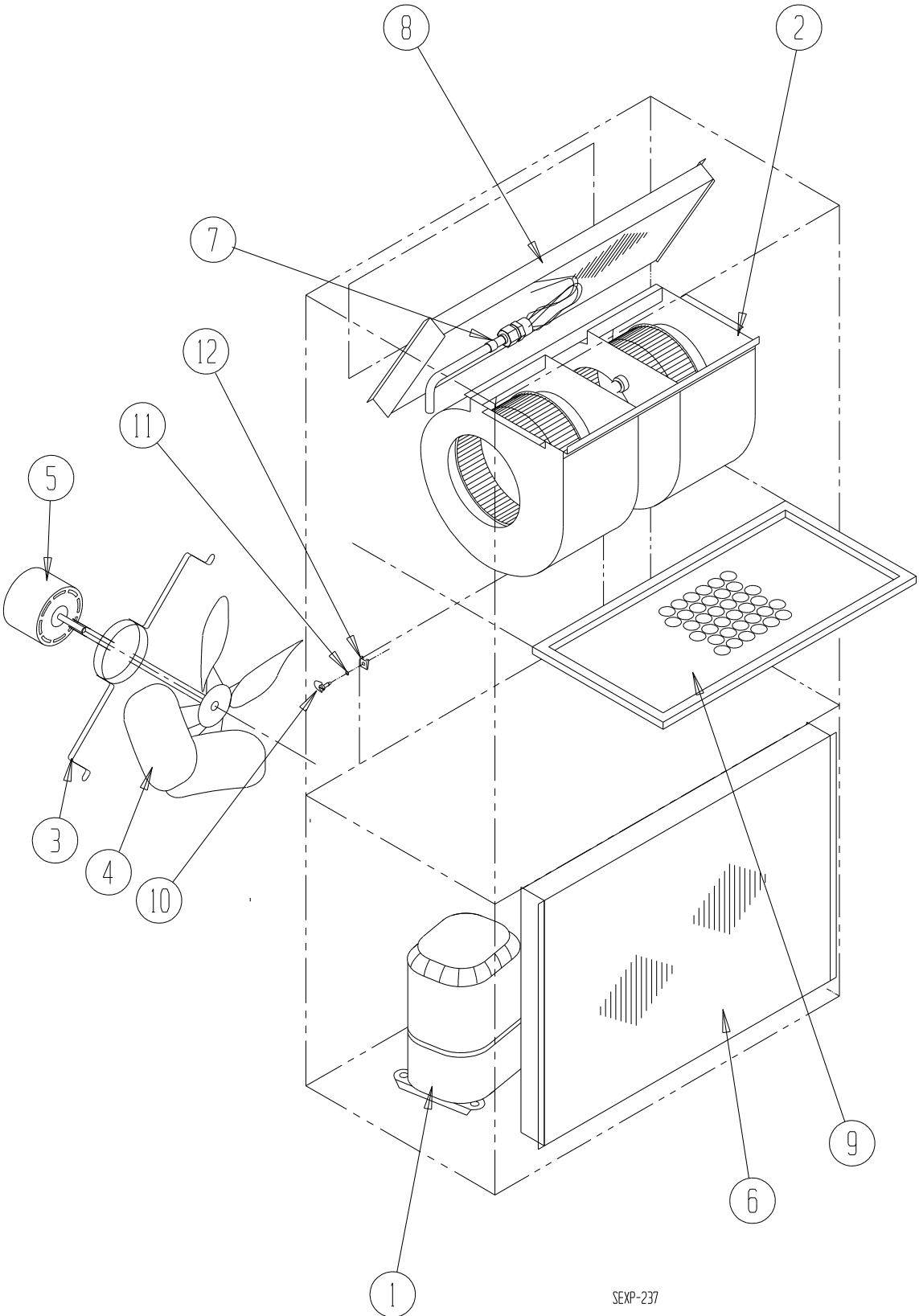

SEXP-237

This drawing is referenced in tables on pages 6 and 7

FUNCTIONAL COMPONENTS

Dwg No.	Part Number	Description	W42LA-A	W42LA-B	W42LA-C	W42LA-F	W48LA-A	W48LA-B	W48LA-C	W48LA-F	W60LA-A	W60LA-B	W60LA-C	W60LA-F
1	8000-349	Compressor	X											
1	8000-350	Compressor		X										
1	8000-351	Compressor			X	X								
1	8000-343	Compressor					X							
1	8000-344	Compressor						X						
1	8000-345	Compressor							X	X				
1	8000-415	Compressor									X			
1	8000-416	Compressor										X		
1	8000-417	Compressor											X	X
2	S900-320	Blower Assembly	X	X		X	X	X		X				
2	S900-321	Blower Assembly			X				X					
2	S900-185	Blower Assembly									X	X		X
2	S900-186	Blower Assembly											X	
3	8200-004	Fan Motor Mount	X	X	X	X	X	X	X	X	X	X	X	X
3	8200-051 ①	Stainless Steel Fan Motor Mount	X	X	X	X	X	X	X	X	X	X	X	X
4	5151-060	Fan Blade	X	X	X	X	X	X	X	X	X	X	X	X
4	5151C060 ①	Coated Fan Blade	X	X	X	X	X	X	X	X	X	X	X	X
5	8105-030	Condenser Motor			X				X				X	
5	8105-066	Condenser Motor	X	X			X	X			X	X		
5	8105-039	Condenser Motor				X				X				X
6	5051-200BX	Condenser Coil	X	X	X	X								
6	5054-200BX	Condenser Coil - Coated	X	X	X	X								
6	5051-198BX	Condenser Coil									X	X	X	X
6	5054-198BX	Condenser Coil - Coated									X	X	X	X
6	5051-199BX	Condenser Coil					X	X	X	X				
6	5054-199BX	Condenser Coil - Coated					X	X	X	X				
7	800-0452	Distributor Assembly	X	X	X	X								
7	800-0451	Distributor Assembly					X	X	X	X				
7	800-0453	Distributor Assembly									X	X	X	X
8	917-0256BX	Evaporator Coil					X	X	X	X				
8	917-0266BX	Evaporator Coil - Coated					X	X	X	X				
8	917-0257BX	Evaporator Coil									X	X	X	X
8	917-0268BX	Evaporator Coil - Coated									X	X	X	X
8	917-0255BX	Evaporator Coil	X	X	X	X								
8	917-0265BX	Evaporator Coil - Coated	X	X	X	X								
9	7004-016	Air Filter 1" Throw-Away (20x30x1)	X	X	X	X	X	X	X	X	X	X	X	X
9	7003-030	Air Filter 1" Washable (20x30x1)	X	X	X	X	X	X	X	X	X	X	X	X
9	7004-027	Air Filter 2" Pleated (20x30x2)	X	X	X	X	X	X	X	X	X	X	X	X
10	1171-022	1/4 Turn Fastener	X	X	X	X	X	X	X	X	X	X	X	X
11	1171-024	1/4 Turn Retainer	X	X	X	X	X	X	X	X	X	X	X	X
12	1171-023	1/4 Receptacle	X	X	X	X	X	X	X	X	X	X	X	X
NS	5201-022	Filter Drier	X	X	X	X	X	X	X	X	X	X	X	X
NS	CMA-28	Low Ambient Control ②	X	X	X	X	X	X	X	X	X	X	X	X
NS	8406-142	High Pressure Switch	X	X	X	X	X	X	X	X	X	X	X	X
NS	8406-140	Low Pressure Switch	X	X	X	X	X	X	X	X	X	X	X	X
NS	5451-024	Tubing Isolation Grommet	2	2	2	2	2	2	2	2	2	2	2	2
NS	6031-009	Coremax Valve Core	2	2	2	2	2	2	2	2	2	2	2	2
NS	8620-113	Compressor Crankcase Heater									X	X	X	X
NS	1171-028	Filter Door Clip	2	2	2	2	2	2	2	2	2	2	2	2
NS	1171-057	Filter Door Screw	2	2	2	2	2	2	2	2	2	2	2	2
NS	1171-027	Filter Door Screw Retainer	2	2	2	2	2	2	2	2	2	2	2	2

NS – Not Shown

① – Used with stainless steel cabinet option

② – Optional on these models

This table references drawing on page 5

FUNCTIONAL COMPONENTS

Dwg No.	Part Number	Description	W72LA-A	W72LA-B	W72LA-C	W72LA-F
1	8000-403	Compressor	X			
1	8000-404	Compressor		X		
1	8000-405	Compressor			X	X
2	S900-348-001	Blower Assembly	X	X		X
2	S900-349-001	Blower Assembly			X	
3	8200-049	Fan Motor Mount	X	X	X	X
3	8200-052 ①	Stainless Steel Fan Motor Mount	X	X	X	X
4	5151-063	Fan Blade	X	X	X	X
4	5151C063 ①	Coated Fan Blade	X	X	X	X
5	8106-067	Condenser Motor			X	
5	8106-016	Condenser Motor	X	X		X
6	5051-197BX	Condenser Coil	X	X	X	X
6	5054-197BX	Condenser Coil - Coated	X	X	X	X
7	800-0454	Distributor Assembly	X	X	X	X
8	917-0347BX	Evaporator Coil	X	X	X	X
8	917-0348BX	Evaporator Coil - Coated	X	X	X	X
9	7004-016	Air Filter 1" Throw-Away (20x30x1)	X	X	X	X
9	7003-030	Air Filter 1" Washable (20x30x1)	X	X	X	X
9	7004-027	Air Filter 2" Pleated (20x30x2)	X	X	X	X
10	1171-022	1/4 Turn Fastener	X	X	X	X
11	1171-024	1/4 Turn Retainer	X	X	X	X
12	1171-023	1/4 Receptacle	X	X	X	X
NS	5201-022	Filter Drier	X	X	X	X
NS	CMA-28	Low Ambient Control (Flare) ②	X	X	X	X
NS	8406-142	High Pressure Switch	X	X	X	X
NS	8406-140	Low Pressure Switch	X	X	X	X
NS	5451-024	Tubing Isolation Grommet	2	2	2	2
NS	CMC-29	Freeze Thermostat Kit	X	X	X	X
NS	6031-009	Coremax Valve Core	2	2	2	2
NS	1171-028	Filter Door Clip	2	2	2	2
NS	1171-057	Filter Door Screw	2	2	2	2
NS	1171-027	Filter Door Screw Retainer	2	2	2	2

NS – Not Shown

① – Used with stainless steel cabinet option

② – Optional on these models

This table references drawing on page 5

CONTROL PANEL

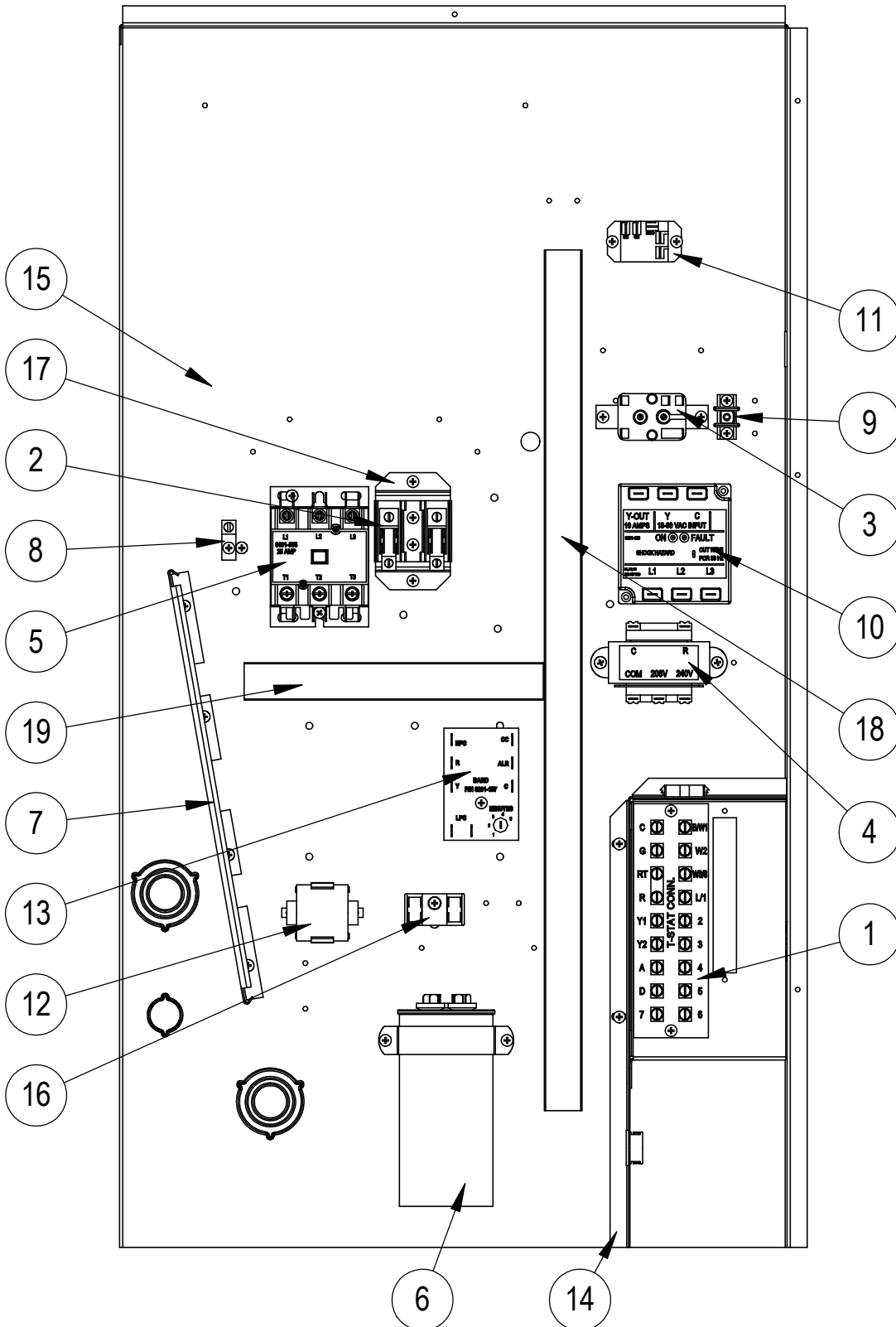

SEXP-791

This drawing is referenced in tables on pages 9 and 10

CONTROL PANEL

Dwg No.	Part Number	Description	W42LA-A	W42LA-B	W42LA-C	W42LA-F	W48LA-A	W48LA-B	W48LA-C	W48LA-F	W60LA-A	W60LA-B	W60LA-C	W60LA-F
1	8607-044	Low Voltage Terminal Strip	X	X	X	X	X	X	X	X	X	X	X	X
2	8607-013	Terminal Block 2 Pole	X			X	X			X	X			X
3	8201-130	Blower Control Relay	X			X	X			X	X			X
3	8201-009	Blower Control Relay		X			X					X		
3	8201-032	Blower Control Relay			X			X					X	
4	8407-068	Transformer	X	X		X	X	X		X	X	X		X
4	8407-042	Transformer			X			X					X	
5	8401-035	Compressor Contactor		X	X	X		X	X	X		X	X	X
5	8401-034	Compressor Contactor	X				X				X			
6	8552-079	Compressor Capacitor	X											
6	8552-005	Outdoor Motor Capacitor		X		X		X		X		X		X
6	8552-026	Outdoor Motor Capacitor			X			X					X	
6	8552-059	Compressor Capacitor									X			
6	8552-089	Compressor Capacitor					X							
7	135-122	Wire Shield	X	X	X	X	X	X	X	X	X	X	X	X
8	8611-006	Ground Terminal	X	X	X	X	X	X	X	X	X	X	X	X
9	8607-041	6 Pin Connector Park Terminal	X	X	X	2	X	X	X	2	X	X	X	2
10	8201-126	Phase Monitor		X	X	X		X	X	X		X	X	X
11	8201-130	Alarm Relay ①	X	X	X	X	X	X	X	X	X	X	X	X
12	8551-004	Start Device (PTCR) ①	X				X				X			
13	8201-157	Compressor Control Module	X	X	X	X	X	X	X	X	X	X	X	X
14	117Y371	Low Voltage Box	X	X	X	X	X	X	X	X	X	X	X	X
15	117Y373	Control Panel	X	X	X	X	X	X	X	X	X	X	X	X
16	8607-017	Terminal Block ①	X	X	X	X	X	X	X	X	X	X	X	X
17	113-601	Terminal Block Bracket				X				X				X
18	8611-140-2300	Cable Duct	X	X	X	X	X	X	X	X	X	X	X	X
19	8611-140-0800	Cable Duct	X	X	X	X	X	X	X	X	X	X	X	X
NS	3000-1222	Compressor Plug/Harness	X				X							
NS	3000-1231	Compressor Plug/Harness		X	X	X		X	X	X				
NS	3000-1508	Compressor Plug/Harness									X			
NS	3000-1509	Compressor Plug/Harness										X	X	X
NS	3003-008	Main Wire Harness	X				X				X			
NS	3003-009	Main Wire Harness		X	X			X	X			X	X	
NS	3003-013	Main Wire Harness				X				X				X
NS	3000-1494	Low Voltage Terminal Block Harness	X	X	X	X	X	X	X	X	X	X	X	X
NS	S910-2005	Complete Low Voltage Box Assembly (Sheet Metal, LVTS & Wire Harness)	X	X	X	X	X	X	X	X	X	X	X	X
NS	8615-040	Circuit Breaker 50A 2 Pole ②	X				X							
NS	8615-042	Circuit Breaker 35A 3 Pole ②		X				X						
NS	8615-067	Toggle Disconnect ②			X	X			X	X			X	X
NS	8615-044	Circuit Breaker 45A 3 Pole ②										X		
NS	8615-041	Circuit Breaker 60A 2 Pole ②									X			
NS	4095-185	Wiring Diagram	X				X				X			
NS	4095-262	Wiring Diagram		X				X				X		
NS	4095-362	Wiring Diagram			X			X					X	
NS	4095-637	Wiring Diagram				X			X					X

① Optional on these models.

② Circuit breakers listed are for units without electric heat "OZ" models. See heater replacement parts manual for units with electric heat.

NS – Not Shown

CONTROL PANEL

Dwg No.	Part Number	Description	W72LA-A	W72LA-B	W72LA-C	W72LA-F
1	8607-044	Low Voltage Terminal Strip	X	X	X	X
2	8607-013	Terminal Block 2 Pole				X
3	8201-130	Blower Control Relay	X	X	X	X
4	8407-068	Transformer	X	X		X
4	8407-042	Transformer			X	
5	8401-035	Compressor Contactor		X	X	X
5	8401-034	Compressor Contactor	X			
6	8552-005	Outdoor Motor Capacitor			X	
6	8552-097	Compressor Capacitor	X			
6	8552-004	Compressor Capacitor		X		X
7	135-122	Wire Shield	X	X	X	X
8	8611-006	Ground Terminal	X	X	X	X
10	8201-126	Phase Monitor		X	X	X
11	8201-130	Alarm Relay ①	X	X	X	X
12	8551-004	Start Device (PTCR) ①	X			
13	8201-157	Compressor Control Module	X	X	X	X
14	117Y371	Low Voltage Box	X	X	X	X
15	117Y373	Control Panel	X	X	X	X
16	8607-017	Terminal Block ①	X	X	X	X
17	113-601	Terminal Block Bracket				X
18	8611-140-2300	Cable Duct	X	X	X	X
19	8611-140-0800	Cable Duct	X	X	X	X
NS	3000-1510	Compressor Plug/Harness	X			
NS	3000-1511	Compressor Plug/Harness		X	X	X
NS	3003-014	Main Wire Harness	X			
NS	3003-015	Main Wire Harness		X	X	
NS	3003-016	Main Wire Harness				X
NS	3000-1494	Low Voltage Terminal Block Harness	X	X	X	X
NS	S910-2005	Complete Low Voltage Box Assembly (Sheet Metal, LVTS & Wire Harness)	X	X	X	X
NS	8607-042	Blower Speed Terminal	X	X	X	X
NS	3000-1512	High Voltage Blower Motor Harness (4 wires)	X	X	X	X
NS	3000-1513	High Voltage Blower Motor Harness (3 wires)	X	X	X	X
NS	8615-067	Toggle Disconnect ②			X	X
NS	8615-041	Circuit Breaker 60A 2 Pole ②	X	X		
NS	4095-188	Wiring Diagram	X			
NS	4095-264	Wiring Diagram		X		
NS	4095-364	Wiring Diagram			X	
NS	4095-638	Wiring Diagram				X

① Optional on these models.

② Circuit breakers listed are for units without electric heat "OZ" models. See heater replacement parts manual for units with electric heat.

NS – Not Shown

This table references drawing on page 8

BLOWER ASSEMBLY

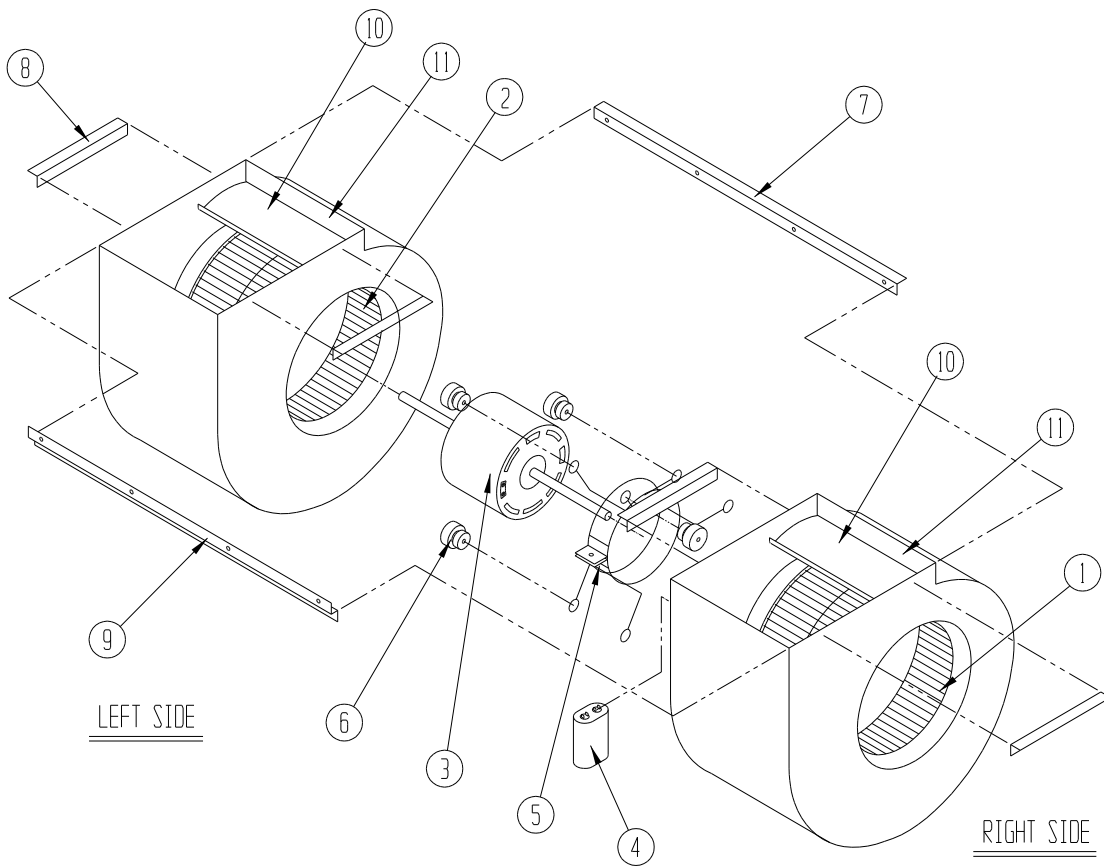

SEXP-178

Dwg No.	Part Number	Description	900-320	900-321	900-185	900-186
1	5152-011	10 Inch Wheel (CW)			X	X
1	5152-057	9 Inch Wheel (CW)	X	X		
2	5152-012	10 Inch Wheel (CW)			X	X
2	5152-058	9 Inch Wheel (CW)	X	X		
3	8105-061	Blower Motor (230/208)	X			
3	8105-062	Blower Motor (460)		X		
3	8106-046	Blower Motor (230/208)			X	
3	8106-025	Blower Motor (460)				X
4	8552-091	Capacitor	X	X		
4	8552-005	Capacitor			X	X
5	8200-040	Motor Mount	X	X	X	X
6	5451-011	Grommets	6	6	6	6
7	105-881	Back Brace	X	X	X	X
8	105-880	Side Angle	4	4	4	4
9	103-389	Front Brace	X	X	X	X
10	151-101	Housing	2	2	2	2
11	144-166	Diffuser	2	2	2	2

BLOWER ASSEMBLY

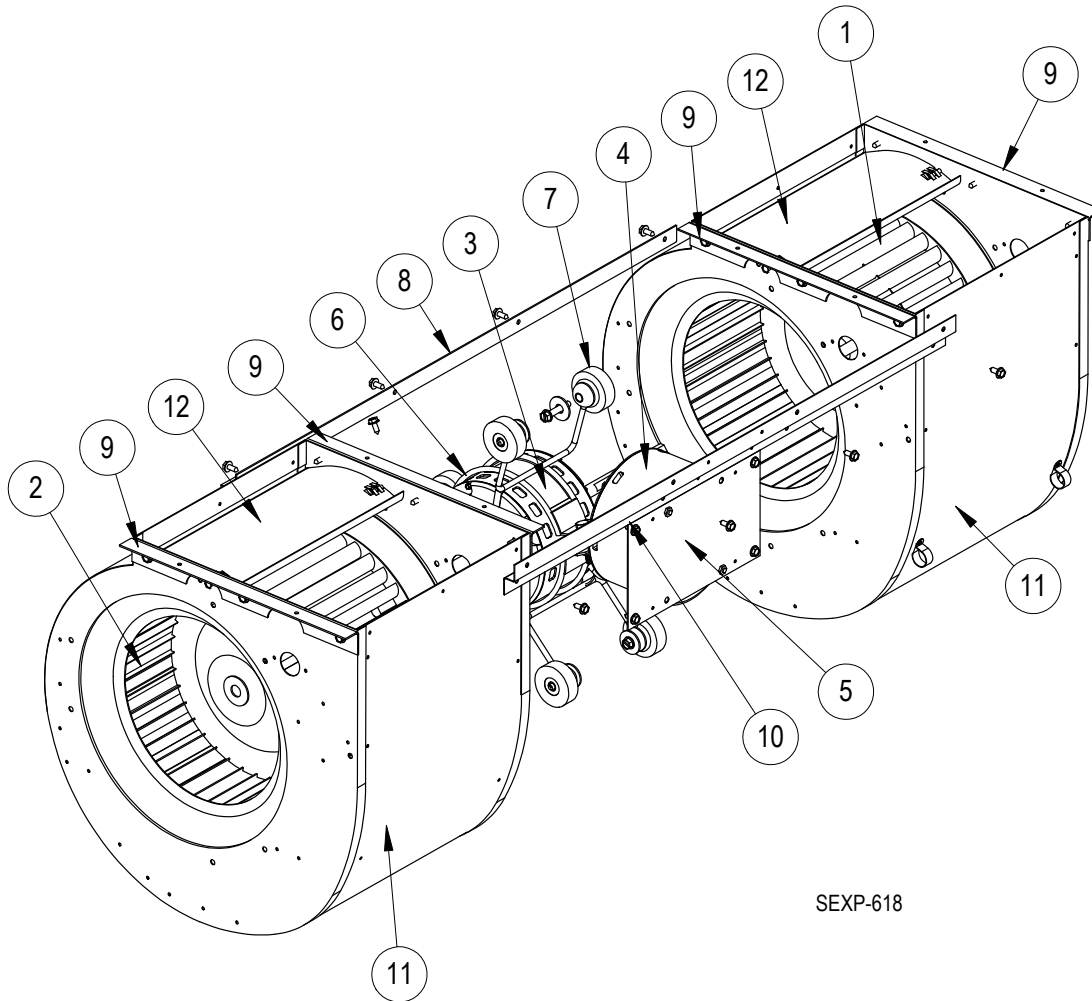

SEXP-618

Dwg. No.	Part Number	Description	S900-348-001	S900-349-001
1	5152-011	10-Inch Wheel (CW)	X	X
2	5152-012	10-Inch Wheel (CCW)	X	X
3	S8107-019-0135	3/4 HP Programmed Motor	X	
3	S8107-026-0136	3/4 HP Programmed Motor		X
4	C8107-019-0135	Programmed Motor Control Only	X	
4	C8107-026-0136	Programmed Motor Control Only		X
5	112-580	Blower Motor Control Bracket	X	X
6	8200-040	Motor Mount	X	X
7	5451-011	Grommets	6	6
8	105-881	Back Brace	X	X
9	105-880	Side Angle	4	4
10	103-389	Front Brace	X	X
11	151-101	Housing	2	2
12	144-166	Diffuser	2	2