REPLACEMENT PARTS MANUAL

WALL MOUNTED PACKAGED AIR CONDITIONER

Models:

W30LA-A W36LA-A
W30LA-B W36LA-B
W30LA-C W36LA-C
W30AA-F W36LA-F

General Notes

- Revised and/or additional pages may be issued from time to time.
- A complete and current manual consists of pages shown in the following contents section.

Important

- Contact the installing and/or local Bard distributor for all parts requirements. Make sure you have the complete model and serial number available from the unit rating plates.

Contents

Description	Page
Cabinet Components	
♦ Exploded View.....	2
♦ Usage List	3
Functional Components	
♦ Exploded View.....	4
♦ Usage List	5
Control Panel	
♦ Layout View	6
♦ Usage List	7
Blower Assembly	
♦ Exploded View.....	8
♦ Usage List	8



Bard Manufacturing Company, Inc.
Bryan, Ohio 43506
www.bardhvac.com

Manual: 2110-1426
Supersedes: **NEW**
Date: 10-6-15

CABINET COMPONENTS

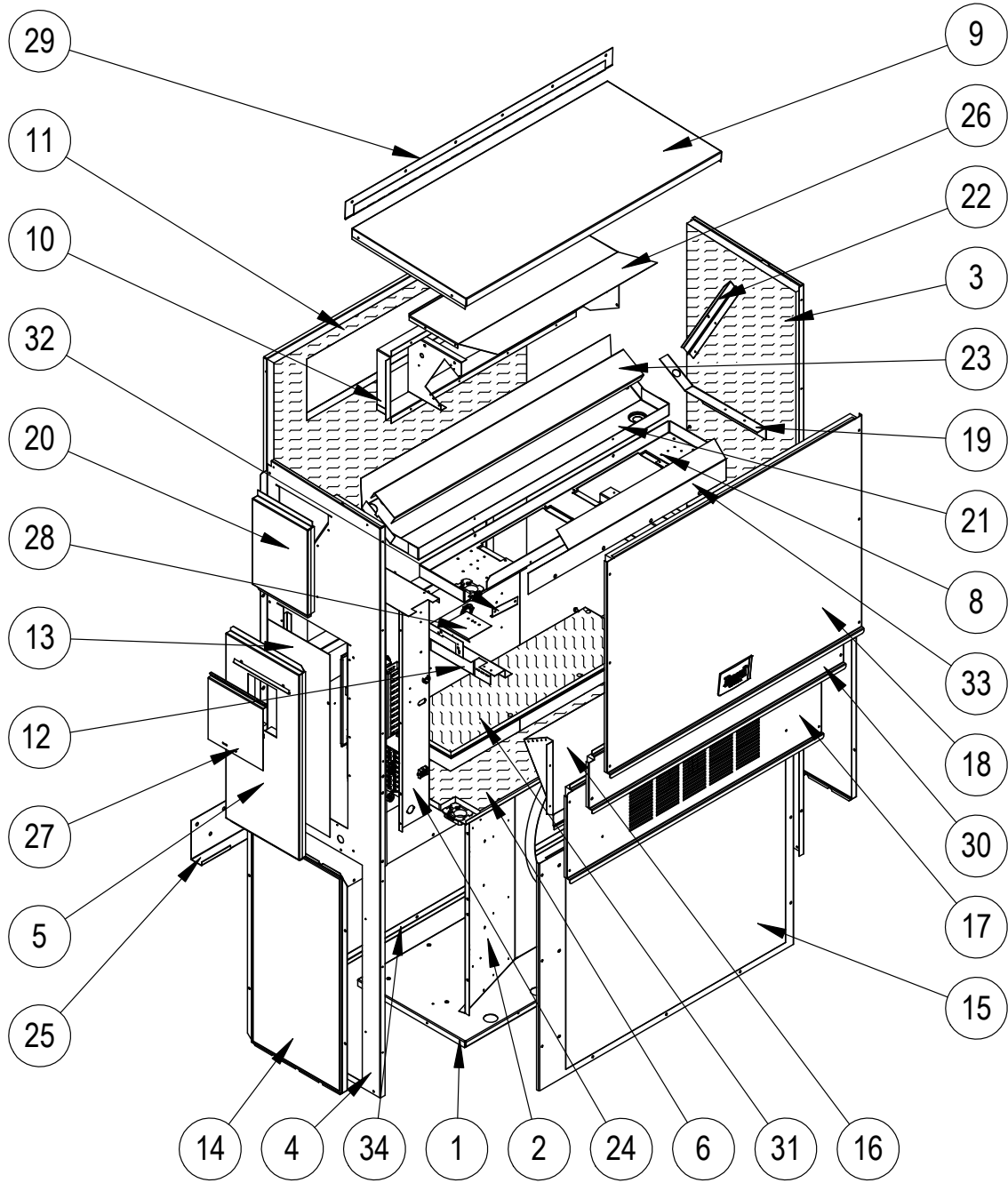

SEXP-802

CABINET COMPONENTS

Dwg No.	Part Number	Description	W30LA-A, B	W30LA-C	W30LA-F	W36LA-A, B	W36LA-C	W36LA-F
1	S127-472	Lower Base	X	X	X	X	X	X
1	S127-474 ②	Lower Base	X	X	X	X	X	X
2	125-081	Fan Shroud	X	X	X	X	X	X
2	125-083 ②	Fan Shroud	X	X	X	X	X	X
3	S501-935-* ①	Right Side	X	X	X	X	X	X
3	S501-945 ②	Right Side	X	X	X	X	X	X
3	S501-943 ③	Right Side	X	X	X	X	X	X
4	S501-936-* ①	Left Side	X	X	X	X	X	X
4	S501-944 ②	Left Side	X	X	X	X	X	X
4	S501-946 ③	Left Side	X	X	X	X	X	X
5	S533-228 ①	Control Panel Cover (Outer)	X	X	X	X	X	X
5	S533-235 ②	Control Panel Cover (Outer)	X	X	X	X	X	X
5	S533-236 ③	Control Panel Cover (Outer)	X	X	X	X	X	X
6	S521Y527	Condenser Partition	X	X	X	X	X	X
8	121Y467	Blower Partition	X	X	X	X	X	X
9	S507-308-* ①	Top	X	X	X	X	X	X
9	S507-319 ②	Top	X	X	X	X	X	X
9	S507-320 ③	Top	X	X	X	X	X	X
10	S111Y030	Outlet Air Frame Assembly	X	X	X	X	X	X
11	S508-343	Back	X	X	X	X	X	X
11	S508-347 ②	Back	X	X	X	X	X	X
11	S508-345	Back	X	X	X	X	X	X
12	113Y480	Filter Bracket	2	2	2	2	2	2
13	S132-104	Control Panel Cover (Inner)	X			X		
13	S132-172	Control Panel Cover (Inner)		X	X		X	X
14	118-105-* ①	Side Grille	2	2	2	2	2	2
14	118-110 ②	Side Grille	2	2	2	2	2	2
14	118-115 ③	Side Grille	2	2	2	2	2	2
15	118-104-* ①	Condenser Grille	X	X	X	X	X	X
15	118-109 ②	Condenser Grille	X	X	X	X	X	X
15	118-114 ③	Condenser Grille	X	X	X	X	X	X
16	BFAD-3	Fresh Air Damper Assembly	X	X	X	X	X	X
17	S553-523-* ①	Vent Option Door	X	X	X	X	X	X
17	S553-549 ②	Vent Option Door	X	X	X	X	X	X
17	S553-550 ③	Vent Option Door	X	X	X	X	X	X
18	S514-241-* ①	Upper Front	X	X	X	X	X	X
18	S514-238 ②	Upper Front	X	X	X	X	X	X
18	S514-239 ③	Upper Front	X	X	X	X	X	X
19	105Y850	Side Support	X	X	X	X	X	X
20	S543-175-* ①	Right Side Cover Plate (Outer)	X	X	X	X	X	X
20	S543-185 ②	Right Side Cover Plate (Outer)	X	X	X	X	X	X
20	S543-184 ③	Right Side Cover Plate (Outer)	X	X	X	X	X	X
21	S123-130	Drain Pan	X	X	X	X	X	X
21	S123-143 ②③	Drain Pan	X	X	X	X	X	X
22	147-044	Evaporator Support	X	X	X	X	X	X
23	137-685	Bottom Evaporator Fill	X	X	X	X	X	X
24	Control Panel Assembly	See Control Panel Assy. Drawing & Parts List Assy.	X	X	X	X	X	X
25	113-140	Bottom Mounting Bracket	X	X	X	X	X	X
26	135Y123	Heat Shield	X	X	X	X	X	X
27	S153-218 ①	Disconnect Access Door	X	X	X	X	X	X
27	S153-405 ②	Disconnect Access Door	X	X	X	X	X	X
27	S153-387 ③	Disconnect Access Door	X	X	X	X	X	X
28	137-259	Fill Plate	X	X	X	X	X	X
29	113-149-* ①	Top Rain Flashing	X	X	X	X	X	X
29	113-360 ②	Top Rain Flashing	X	X	X	X	X	X
29	113-149-4 ③	Top Rain Flashing	X	X	X	X	X	X
30	S553-524-* ①	Filter Door	X	X	X	X	X	X
30	S553-553 ②	Filter Door	X	X	X	X	X	X
30	S553-554 ③	Filter Door	X	X	X	X	X	X
31	S536-498	Cond. Partition Block Off Plate	X	X	X	X	X	X
32	105-1302	Grommet Retainer	X	X	X	X	X	X
33	135-329	Air Baffle	X	X	X	X	X	X
34	105-1393	Close Off Angle	X	X	X	X	X	X

① Exterior cabinet parts are manufactured with various paint color options. To ensure the proper paint color is received, include the complete model and serial number of the unit for which cabinet parts are being ordered.

② Exterior cabinet parts are manufactured from stainless steel Code "S"

③ Exterior cabinet parts are manufactured from aluminum Code "A"

FUNCTIONAL COMPONENTS

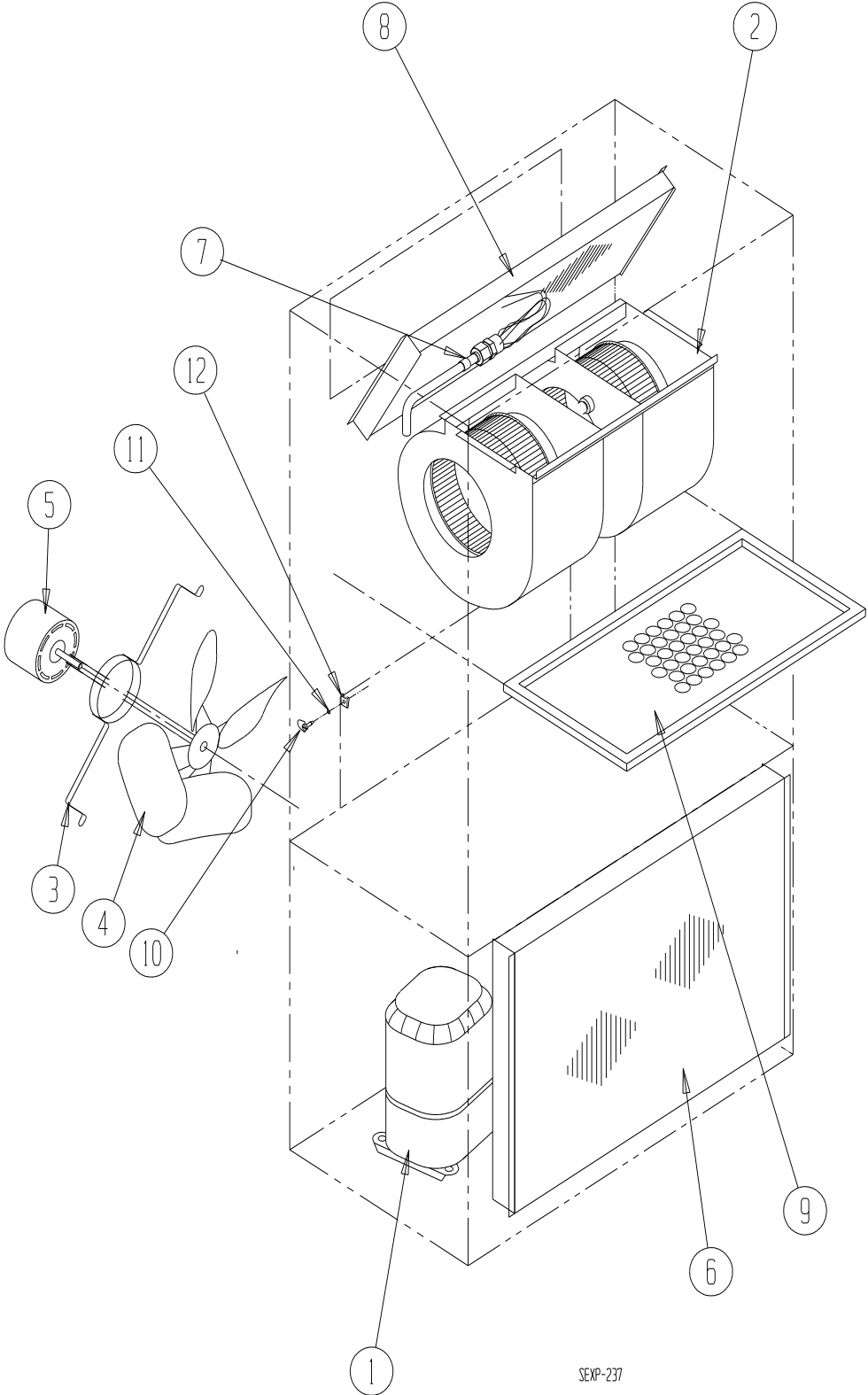

SEXP-237

FUNCTIONAL COMPONENTS

Dwg No.	Part Number	Description	W30LA-A	W30LA-B	W30LA-C	W30LA-F	W36LA-A	W36LA-B	W36LA-C	W36AA-F
1	8000-346	Compressor	X							
1	8000-347	Compressor		X						
1	8000-348	Compressor			X	X				
1	8000-309	Compressor					X			
1	8000-310	Compressor						X		
1	8000-311	Compressor							X	X
2	S900-231	Blower Assembly	X	X		X	X	X		X
2	S900-232	Blower Assembly			X				X	
3	8200-001	Fan Motor Mount	X	X	X	X	X	X	X	X
4	5151-045	Fan Blade	X	X	X	X	X	X	X	X
5	8103-013	Condenser Motor	X	X		X	X	X		X
5	8103-020	Condenser Motor			X				X	
6	5051-203BX	Condenser Coil	X	X	X	X				
6	5054-203BX	Condenser Coil – Coated	X	X	X	X				
6	5051-202BX	Condenser Coil					X	X	X	X
6	5054-202BX	Condenser Coil – Coated					X	X	X	X
7	800-0456	Distributor Assembly					X	X	X	X
7	800-0457	Distributor Assembly	X	X	X	X				
8	917-0275BX	Evaporator Coil w/Distributor Assy.	X	X	X	X				
8	917-0285BX	Evaporator Coil – Coated w/Distributor Assy.	X	X	X	X				
8	917-0274BX	Evaporator Coil w/Distributor Assy.					X	X	X	X
8	917-0287BX	Evaporator Coil – Coated w/Distributor Assy.					X	X	X	X
9	7004-019	Air Filter 1" Throw-Away (16x30x1)	X	X	X	X	X	X	X	X
9	7003-031	Air Filter 1" Washable ① (16x30x1)	X	X	X	X	X	X	X	X
9	7004-026	Air Filter 2" Pleated ① (16x30x2)	X	X	X	X	X	X	X	X
10	1171-022	1/4" Turn Fastener	X	X	X	X	X	X	X	X
11	1171-024	1/4" Turn Retainer	X	X	X	X	X	X	X	X
12	1171-023	1/4" Receptacle	X	X	X	X	X	X	X	X
NS	8406-142	High Pressure Switch (Screw On)	X	X	X	X	X	X	X	X
NS	8406-140	Low Pressure Switch (Screw On)	X	X	X	X	X	X	X	X
NS	CMA-28	Low Ambient Control (Screw On) ①	X	X	X	X	X	X	X	X
NS	5201-021	Filter Drier	X	X	X	X	X	X	X	X
NS	5451-024	Tubing Isolation Grommet	X	X	X	X	X	X	X	X
NS	6031-009	Coremax Valve Core	X	X	X	X	X	X	X	X
NS	1171-028	Filter Door Clip	X	X	X	X	X	X	X	X
NS	1171-057	Filter Door Screw	X	X	X	X	X	X	X	X
NS	1171-027	Filter Door Screw Retainer	X	X	X	X	X	X	X	X

NS – Not Shown

① – Optional on these models

CONTROL PANEL

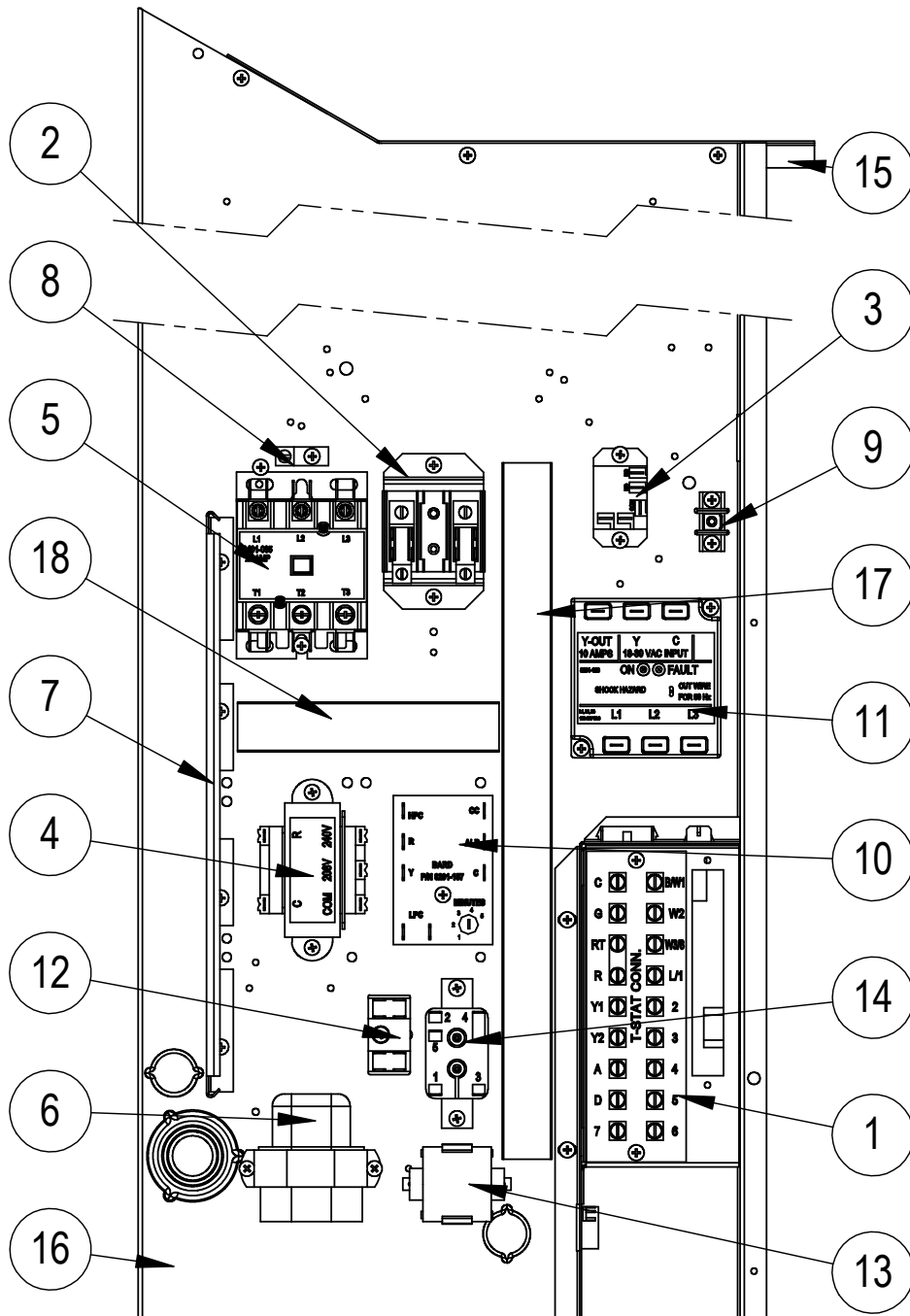

SEXP-803

CONTROL PANEL

Dwg No.	Part Number	Description	W30LA-A	W30LA-B	W30LA-C	W30LA-F	W36LA-A	W36LA-B	W36LA-C	W36LA-F
1	8607-044	Low Voltage Terminal Strip	X	X	X	X	X	X	X	X
2	8607-013	Terminal Block 2 Pole				X				X
2	113-601	Terminal Block Bracket				X				X
3	8201-130	Blower Control Relay	X			X	X			X
3	8201-009	Blower Control Relay		X				X		
3	8201-032	Blower Control Relay			X				X	
4	8407-034	Transformer	X	X		X	X	X		X
4	8407-042	Transformer			X				X	
5	8401-033	Compressor Contactor	X				X			
5	8401-035	Compressor Contactor		X	X	X		X	X	X
6	8552-052	Compressor Capacitor	X				X			
6	8552-002	Outdoor Motor Capacitor		X	X	X		X	X	X
7	135-122	Wire Shield	X	X	X	X	X	X	X	X
8	8611-006	Ground Terminal	X	X	X	X	X	X	X	X
9	8607-041	Park Terminal	X	X	X	X	X	X	X	X
10	8201-157	Compressor Control Module	X	X	X	X	X	X	X	X
11	8201-126	Phase Monitor		X	X	X		X	X	X
12	8607-017	Terminal Block (Optional)	X	X	X	X	X	X	X	X
13	8551-004	Start Device (PTCR) (Optional)	X	X	X	X	X	X	X	X
14	8201-062	Alarm Relay (Optional)	X	X	X	X	X	X	X	X
15	117Y137	Control Panel Top	X	X	X	X	X	X	X	X
16	117Y374	Control Panel	X	X	X	X	X	X	X	X
17	8611-140-1400	Cable Duct	X	X	X	X	X	X	X	X
18	8611-140-0500	Cable Duct	X	X	X	X	X	X	X	X
NS	8615-038	Circuit Breaker 35A 2 Pole (Opt.) ①	X				X			
NS	8615-054	Circuit Breaker 20A 3 Pole (Opt.) ①		X						
NS	8615-052	Circuit Breaker 30A 3 Pole (Opt.) ①						X		
NS	8615-067	Toggle Disconnect (Optional) ①			X	X			X	X
NS	4095-185	Wiring Diagram	X				X			
NS	4095-262	Wiring Diagram		X				X		
NS	4095-362	Wiring Diagram			X				X	
NS	4095-639	Wiring Diagram				X				X
NS	3000-1224	Compressor Plug/Harness	X				X			
NS	3000-1231	Compressor Plug/Harness		X	X	X		X	X	X
NS	3003-017	Control Panel Harness	X				X			
NS	3003-018	Control Panel Harness		X	X			X	X	
NS	3003-019	Control Panel Harness				X				X
NS	3000-1494	Low Voltage Terminal Block Harness	X	X	X	X	X	X	X	X

NS = Not Shown

① Circuit breakers listed are for units without electric heat, "OZ" models. Hot gas bypass models not available without electric heat. See Heater Replacement Parts Manual for units with electric heat.

BLOWER ASSEMBLY

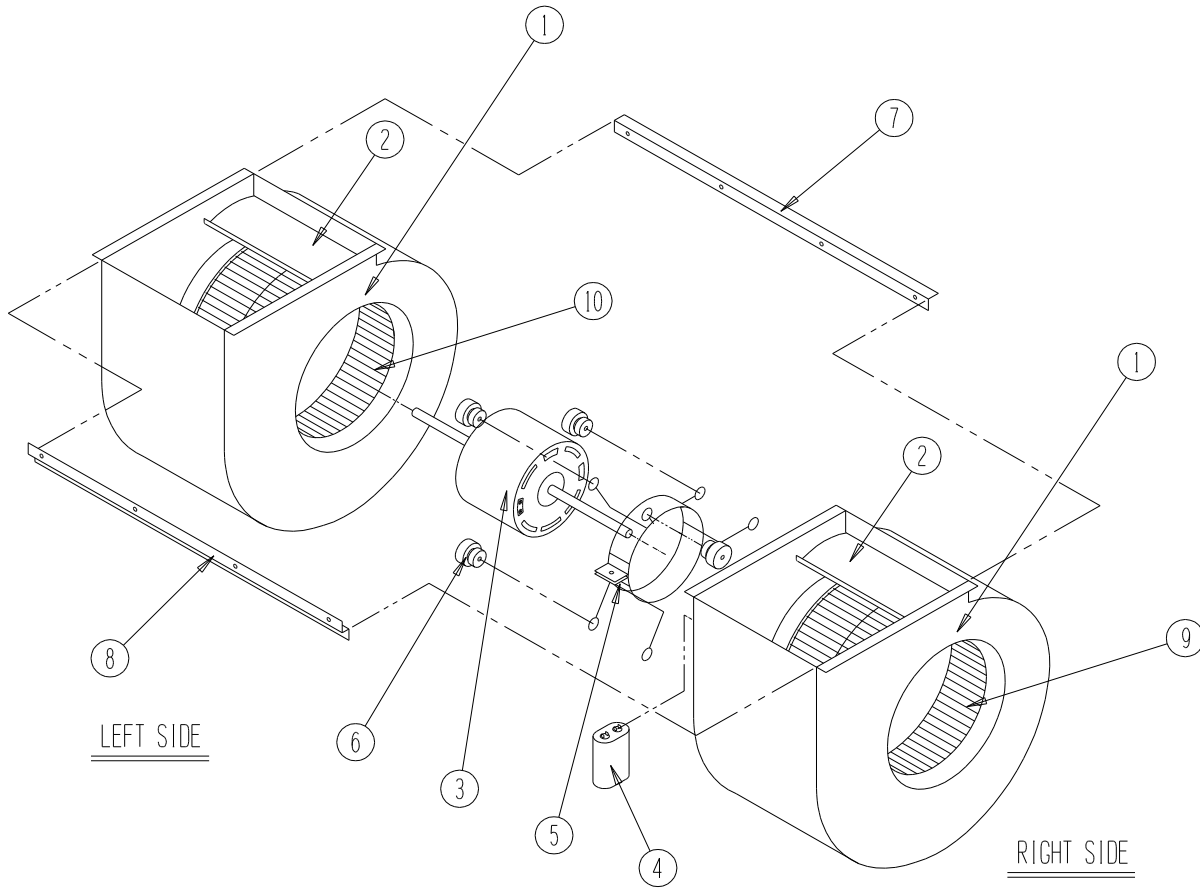

SEXP-346

Dwg No.	Part Number	Description	S900-231	S900-232
1	151-111	Housing	2	2
2	144-174	Diffuser	2	2
3	8105-029	Blower Motor (230/208)	X	
3	8105-033	Blower Motor (460)		X
4	8552-002	Capacitor	X	X
5	8200-031	Motor Mount	X	X
6	5451-011	Grommets	6	6
7	105-870	Back Brace	X	X
8	103-401	Front Brace	X	X
9	5152-090	Wheel CW	X	X
10	5152-091	Wheel CCW	X	X