

---

# REPLACEMENT PARTS MANUAL

---

## WALL MOUNTED PACKAGED AIR CONDITIONER

Models:

W18AA-A W24AA-A  
W24AA-B  
W24AA-C  
W24AA-D  
W24AA-F

---

### General Notes

- Revised and/or additional pages may be issued from time to time.
- A complete and current manual consists of pages shown in the following contents section.

### Important

- Contact the installing and/or local Bard distributor for all parts requirements. Make sure you have the complete model and serial number available from the unit rating plates.

### Contents

<u>Description</u>	<u>Page</u>
Cabinet Components	
♦ Exploded View .....	2
♦ Usage List .....	3
Functional Components	
♦ Exploded View .....	4
♦ Usage List .....	5
Control Panel	
♦ Layout View .....	6
♦ Usage List .....	7
Blower Assembly	
♦ Exploded View .....	8
♦ Usage List .....	8



Bard Manufacturing Company, Inc.  
Bryan, Ohio 43506  
www.bardhvac.com

Manual: 2110-1427G  
Supersedes: 2110-1427F  
Date: 8-1-18

# CABINET COMPONENTS

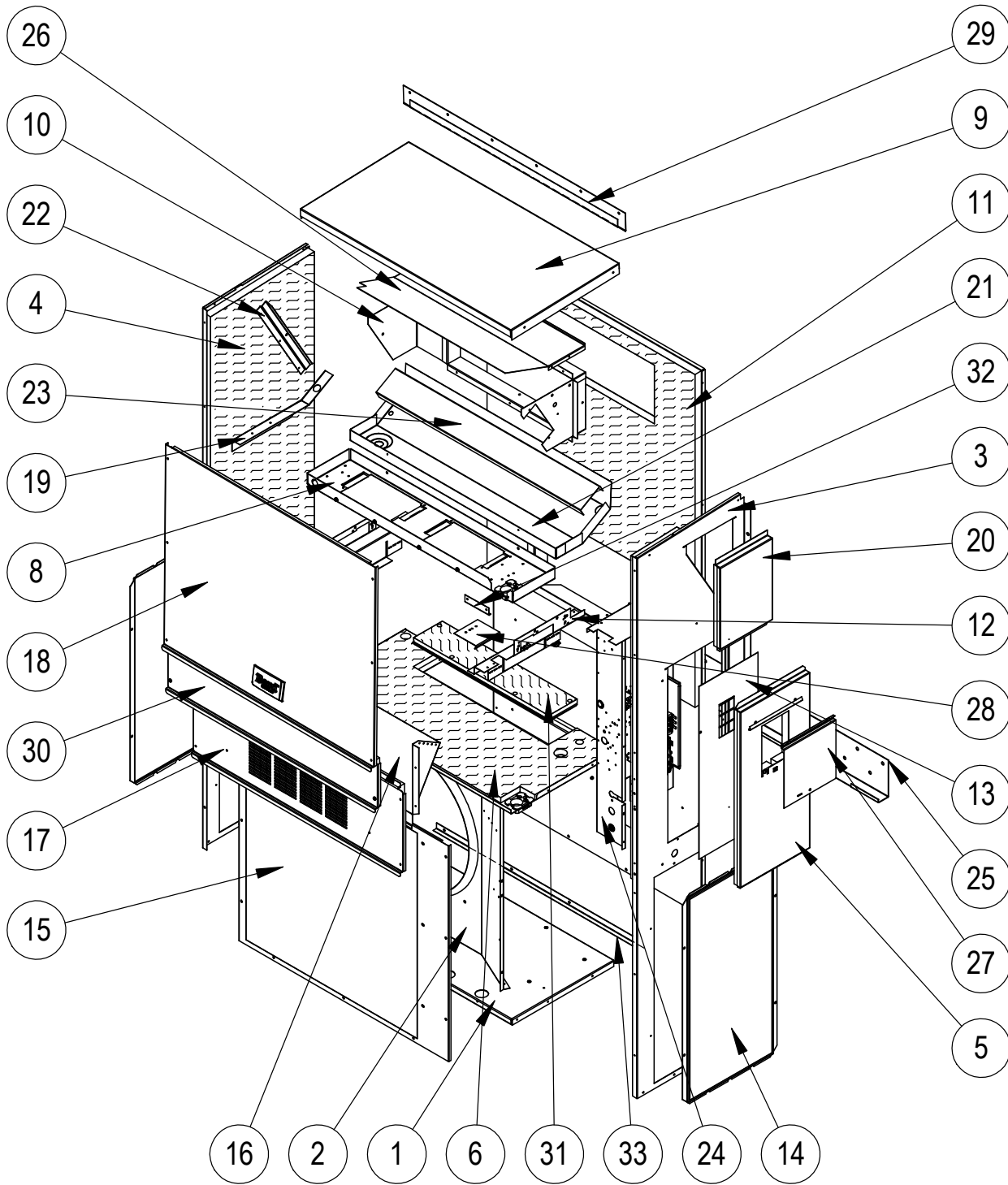

SEXP-804

# CABINET COMPONENTS

Dwg No.	Part Number	Description	W18AA-A	W24AA-A, B, D	W24AA-F, C
1	S127-467	Lower Base	X	X	X
1	S127-534 ②	Lower Base	X	X	X
2	125-080	Fan Shroud	X	X	X
2	125-082 ②	Fan Shroud	X	X	X
3	S501-933-* ①	Right Side	X	X	X
3	S501-994 ②	Right Side	X	X	X
3	S501-937 ③	Right Side	X	X	X
4	S501-934-* ①	Left Side	X	X	X
4	S501-995 ②	Left Side	X	X	X
4	S501-940 ③	Left Side	X	X	X
5	S533-228-* ①	Control Panel Cover (Outer)	X	X	X
5	S533-235 ②	Control Panel Cover (Outer)	X	X	X
5	S533-236 ③	Control Panel Cover (Outer)	X	X	X
6	S521X528	Condenser Partition	X	X	X
6	S521-553 ②	Condenser Partition	X	X	X
8	121X480	Blower Partition	X	X	X
9	S507-311-* ①	Top	X	X	X
9	S507-318-* ③	Top	X	X	X
9	S507-317 ②	Top	X	X	X
10	S111X032	Outlet Air Frame Assembly	X	X	X
11	S508-342	Back	X	X	X
11	S508-344 ③	Back	X	X	X
11	S508-391 ②	Back	X	X	X
12	113X480	Filter Bracket	2	2	2
13	S132-104	Control Panel Cover (Inner)	X	X	
13	S132-172	Control Panel Cover (Inner)			X
14	118-105-* ①	Side Grille	2	2	2
14	118-110 ②	Side Grille	2	2	2
14	118-115 ③	Side Grille	2	2	2
15	118-101-* ①	Condenser Grille	X	X	X
15	118-106 ②	Condenser Grille	X	X	X
15	118-111 ③	Condenser Grille	X	X	X
16	BFAD-2	Fresh Air Damper Assembly	X	X	X
17	S553-537-* ①	Vent Option Door	X	X	X
17	S553-548 ③	Vent Option Door	X	X	X
17	S553-555-* ②	Vent Option Door with ERV	X	X	X
17	S553-539 ①	Vent Option Door with ERV	X	X	X
17	S553-556 ③	Vent Option Door with ERV	X	X	X
17	S553-547 ②	Vent Option Door	X	X	X
18	S514-240-* ①	Upper Front	X	X	X
18	S514-237-* ③	Upper Front	X	X	X
18	S514-236 ②	Upper Front	X	X	X
19	105X850	Side Support	X	X	X
20	S543-175-* ①	Right Side Cover Plate (Outer)	X	X	X
20	S543-185 ②	Right Side Cover Plate (Outer)	X	X	X
20	S543-184 ③	Right Side Cover Plate (Outer)	X	X	X
21	S123-126	Drain Pan	X	X	X
21	S123-140 ②③	Drain Pan	X	X	X
22	147-044	Evaporator Support	X	X	X
23	137-694	Bottom Evaporator Fill	X	X	X
24	Control Panel Assembly	See Control Panel Assy. Drawing & Parts List Assy.	X	X	X
25	113-140	Bottom Mounting Bracket	X	X	X
26	135X127	Heat Shield	X	X	X
27	S153-218 ①	Disconnect Access Door	X	X	X
27	S153-405 ②	Disconnect Access Door	X	X	X
27	S153-387 ③	Disconnect Access Door	X	X	X
28	137-259	Fill Plate	X	X	X
29	113-141-* ①	Top Rain Flashing	X	X	X
29	113-361 ②	Top Rain Flashing	X	X	X
29	113-141-4 ③	Top Rain Flashing	X	X	X
30	S553-538-* ①	Filter Door	X	X	X
30	S553-552-* ③	Filter Door	X	X	X
30	S553-551 ②	Filter Door	X	X	X
31	S536-176	Cond. Partition Block Off Plate	X	X	X
31	S536-878 ②	Cond. Partition Block Off Plate	X	X	X
32	105-1302	Grommet Retainer	X	X	X
33	105-1392	Close Off Angle	X	X	X

① Exterior cabinet parts are manufactured with various paint color options. To ensure the proper paint color is received, include the complete model and serial number of the unit for which cabinet parts are being ordered.

② Exterior cabinet parts are manufactured from stainless steel Code "S"

③ Exterior cabinet parts are manufactured from aluminum Code "A"

# FUNCTIONAL COMPONENTS

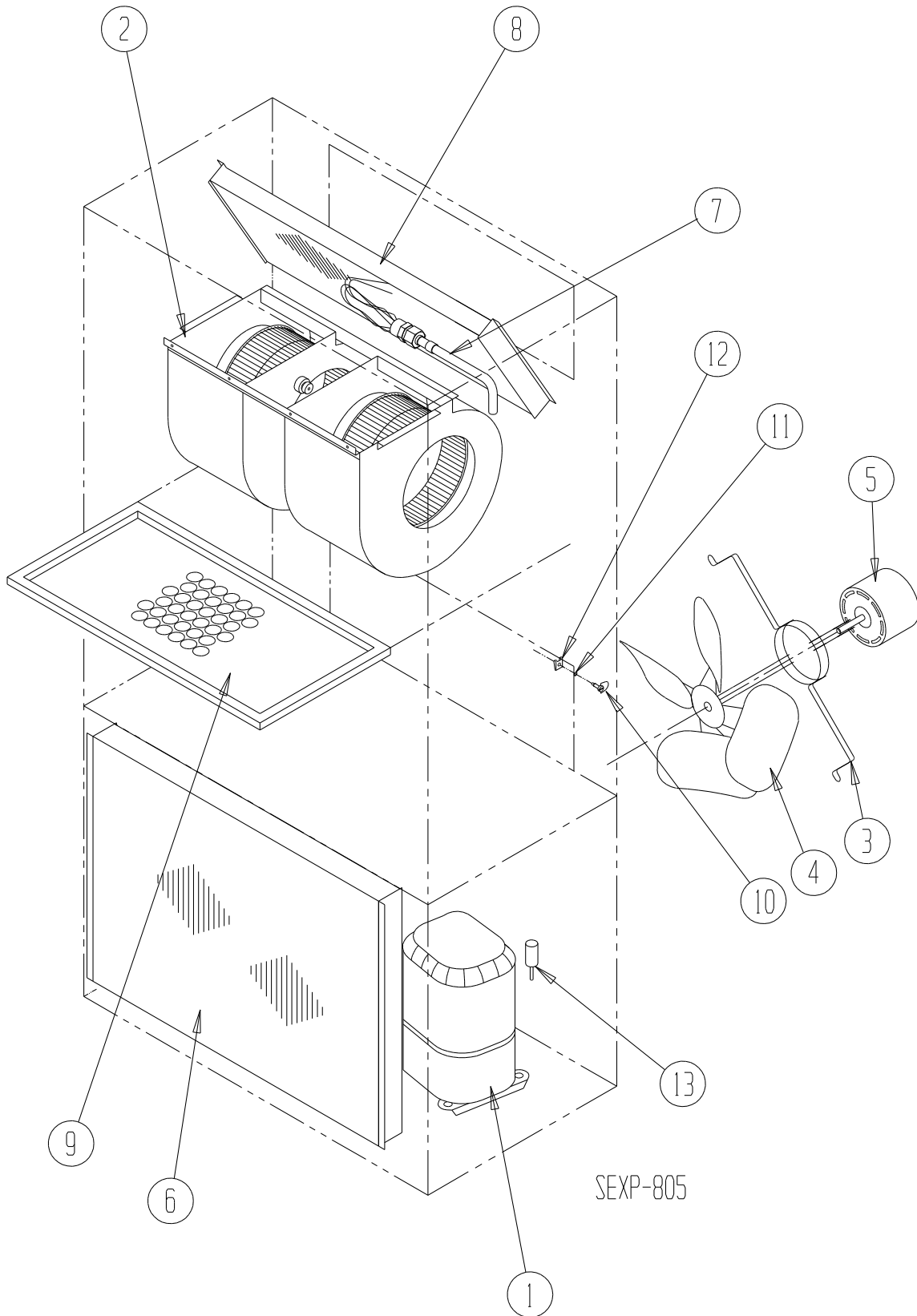

# FUNCTIONAL COMPONENTS

Dwg No.	Part Number	Description	W18AA-A	W24AA-A	W24AA-B	W24AA-C	W24AA-D	W24AA-F
1	8000-313	Compressor	X					
1	8000-314	Compressor		X				
1	8000-315	Compressor			X			
1	8000-316	Compressor				X		X
1	8000-317	Compressor					X	
2	S900-326	Blower Assembly		X	X		X	X
2	S900-327	Blower Assembly				X		
2	S900-291	Blower Assembly	X					
3	8200-001	Fan Motor Mount	X	X	X	X	X	X
3	8200-050 ①	Stainless Steel Fan Motor Mount	X	X	X	X	X	X
4	5151-033	Fan Blade	X	X	X		X	X
4	5151C003 ①	Coated Fan Blade	X	X	X		X	X
4	5151-046	Fan Blade				X		
4	5151C046 ①	Coated Fan Blade				X		
5	8103-016	Condenser Motor	X	X	X		X	X
5	8103-020	Condenser Motor				X		
6	5051-205BX	Condenser Coil	X					
6	5054-205BX	Condenser Coil – Coated	X					
6	5051-204BX	Condenser Coil		X	X	X	X	X
6	5054-204BX	Condenser Coil – Coated		X	X	X	X	X
7	800-0458	Distributor Assembly	X					
7	800-0459	Distributor Assembly		X	X	X	X	X
8	917-0276BX	Evaporator Coil with Distributor Assembly	X					
8	917-0283BX	Evaporator Coil – Coated with Distributor Assembly	X					
8	917-0277BX	Evaporator Coil with Distributor Assembly		X	X	X	X	X
8	917-0284BX	Evaporator Coil – Coated with Distributor Assembly		X	X	X	X	X
9	7004-011	Air Filter 1" Throw-Away (16x25x1)	X	X	X	X	X	X
9	7003-032	Air Filter 1" Washable ② (16x25x1)	X	X	X	X	X	X
9	7004-025	Air Filter 2" Pleated ② (16x25x2)	X	X	X	X	X	X
10	1171-022	1/4" Turn Fastener	X	X	X	X	X	X
11	1171-024	1/4" Turn Retainer	X	X	X	X	X	X
12	1171-023	1/4" Receptacle	X	X	X	X	X	X
13	8406-142	High Pressure Switch (Screw On)	X	X	X	X	X	X
13	8406-140	Low Pressure Switch (Screw On)	X	X	X	X	X	X
NS	CMA-33	Modulating Low Ambient Control (Screw On) ②	X	X	X		X	X
NS	CMA-34	460V Modulating Low Ambient Control ②				X		
NS	5201-021	Filter Drier	X	X	X	X	X	X
NS	5451-024	Tubing Isolation Grommet	X	X	X	X	X	X
NS	6031-009	Coremax Value Core	X	X	X	X	X	X
NS	1171-028	Filter Door Clip	2	2	2	2	2	2
NS	1171-057	Filter Door Screw	2	2	2	2	2	2
NS	1171-027	Filter Door Screw Retainer	2	2	2	2	2	2

NS – Not Shown

① – Used with stainless steel cabinet option

② – Optional on these models

# CONTROL PANEL

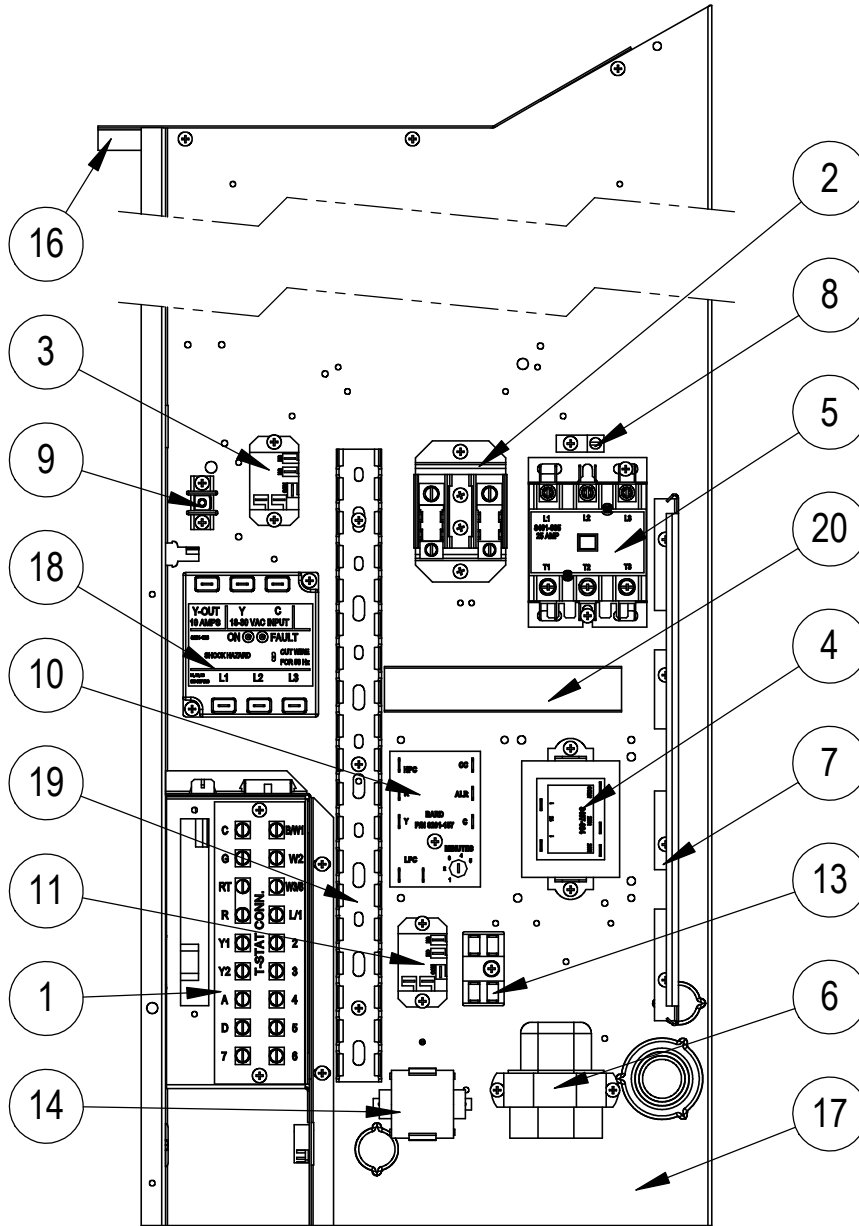

SEXP-806A

# CONTROL PANEL

Dwg No.	Part Number	Description	W18AA-A	W24AA-A	W24AA-B	W24AA-C	W24AA-D	W24AA-F
1	8607-044	Low Voltage Terminal Strip	X	X	X	X	X	X
2	8607-013	Terminal Block 2 Pole						X
2	113-601	Terminal Block Bracket						X
3	8201-130	Blower Control Relay	2	X			X	X
3	8201-009	Blower Control Relay			X			
3	8201-032	Blower Control Relay				X		
4	8407-068	Transformer	X	X	X		X	X
4	8407-069	Transformer				X		
5	8401-033	Compressor Contactor	X	X			X	
5	8401-035	Compressor Contactor			X	X		X
6	8552-046	Compressor Capacitor	X					
6	8552-051	Compressor Capacitor		X			X	
6	8552-002	Outdoor Motor Capacitor			X	X		X
7	135-122	Wire Shield	X	X	X	X	X	X
8	8611-006	Ground Terminal	X	X	X	X	X	X
9	8607-041	Park Terminal	X					
10	8201-164	Compressor Control Module	X	X	X	X	X	X
11	8201-130	Alarm Relay (Optional)	X	X	X	X	X	X
13	8607-017	Terminal Block (Optional)	X	X	X	X	X	X
14	8551-004	Start Device (PTCR) (Optional)	X	X			X	
16	117X137	Control Panel Top	X	X	X	X	X	X
17	117X374	Control Panel	X	X	X	X	X	X
18	8201-126	Phase Monitor			X	X		X
19	8611-140-1400	Cable Duct	X	X	X	X	X	X
20	8611-140-0500	Cable Duct	X	X	X	X	X	X
NS	8615-035	Circuit Breaker 20A 2 Pole (Opt.) ①	X					X
NS	8615-036	Circuit Breaker 25A 2 Pole (Opt.) ①		X				
NS	8615-067	Toggle Disconnect (Optional) ①				X		X
NS	8615-056	Circuit Breaker 15A 3 Pole (Opt.) ①			X			
NS	4095-189	Wiring Diagram	X					
NS	4095-185	Wiring Diagram		X			X	
NS	4095-262	Wiring Diagram			X			
NS	4095-362	Wiring Diagram				X		
NS	4095-639	Wiring Diagram						X
NS	3000-1224	Compressor Plug/Harness	X	X			X	
NS	3000-1231	Compressor Plug/Harness			X	X		X
NS	3000-017	Control Panel Harness		X			X	
NS	3000-018	Control Panel Harness			X	X		
NS	3000-019	Control Panel Harness						X
NS	3000-022	Control Panel Harness	X					
NS	3000-1494	Low Voltage Terminal Block Harness	X	X	X	X	X	X
NS	S910-2002	Complete Low Voltage Box Assembly (Sheet Metal, LVTS & Wire Harness)	X	X	X	X	X	X

NS = Not Shown

① Circuit breakers listed are for units without electric heat, "OZ" models. Hot gas bypass models not available without electric heat. See heater replacement parts manual for units with electric heat.

# BLOWER ASSEMBLY

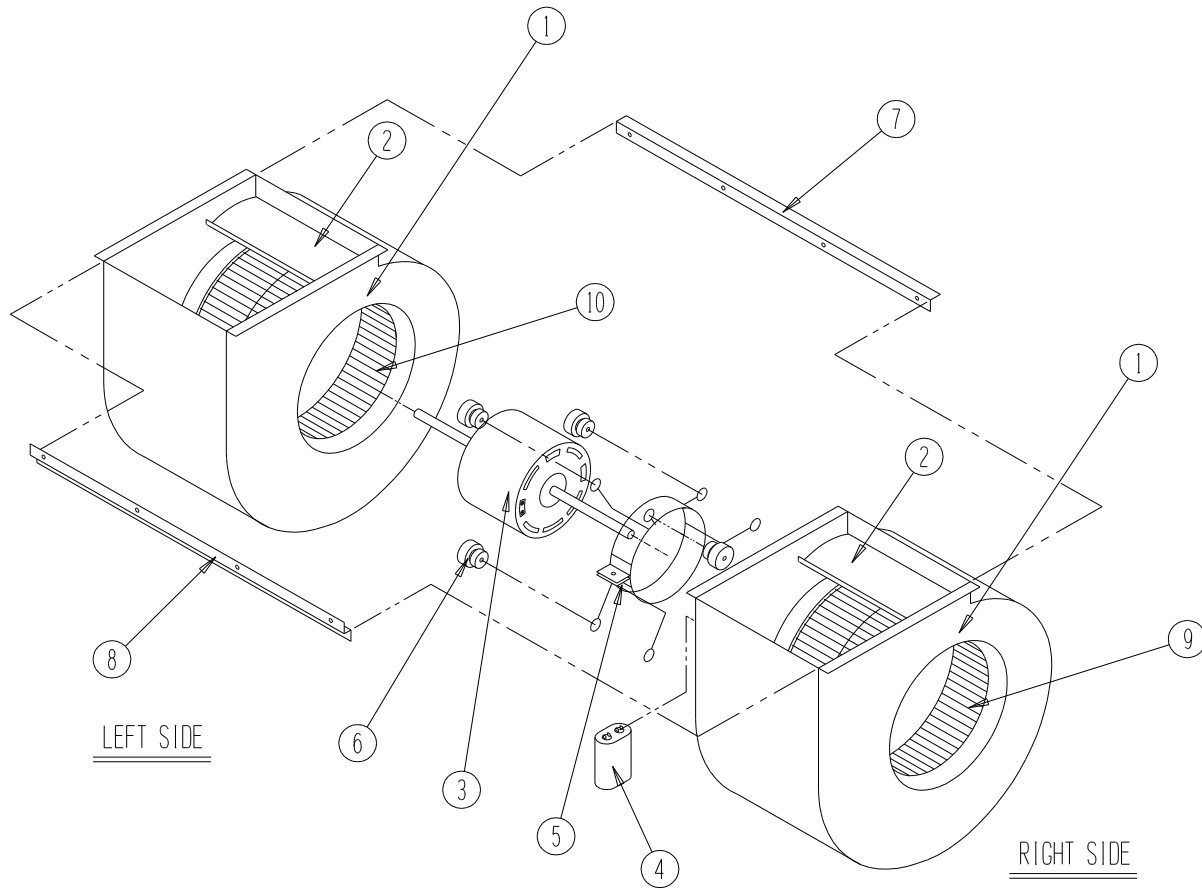

SEXP-346

Dwg No.	Part Number	Description	S900-326	S900-327	S900-291
1	151-115	Housing	2	2	2
2	144-183	Cutoff	X	X	X
3	8102-016	Blower Motor (230/208)	X		
3	8102-017	Blower Motor (460)		X	
3	8102-014	Blower Motor (230/208)			X
4	8552-002	Capacitor			X
4	8552-004	Capacitor	X	X	
5	8200-031	Motor Mount	X	X	X
6	5451-011	Grommets	6	6	6
7	105-1061	Back Brace	X	X	X
8	103-435	Front Brace	X	X	X
9	5152-092	Wheel 9-6 CW	X	X	X
10	5152-093	Wheel 9-6 CCW	X	X	X