

REPLACEMENT PARTS MANUAL

DC FREE COOLING UNIT SYSTEM

AIR CONDITIONER MODELS

D28A2PA	D36A2PA	D42A2PA	D48A2PA	D60A2PA
D28A2PB	D36A2PB	D42A2PB	D48A2PB	D60A2PB
D28L2PA	D36L2PA	D42L2PA	D48L2PA	D60L2PA
D28L2PB	D36L2PB	D42L2PB	D48L2PB	D60L2PB

CONTROLLER MODELS

LC1000 LC1500 LC2000

<u>Description</u>	<u>Page</u>	<u>Description</u>	<u>Page</u>
Cabinet Components – Right Hand		DC Freecooling Air Hood	
♦ Exploded View	2	♦ Exploded View	20
♦ Usage List	3	♦ Usage List	20
Cabinet Components – Left Hand		DC Freecooling Damper Motor	
♦ Exploded View	4	♦ Exploded View	21
♦ Usage List	5	♦ Usage List	21
Functional Components		Bard-Link™ PLC Lead/Lag Controller	
♦ Exploded View	6	♦ Layout View	22
♦ Usage List	7, 8	♦ Usage List	22
Control Panel – Right Hand		General Notes	
♦ Layout View	10	➤ Revised and/or additional pages may be issued from time to time.	
♦ Usage List	11, 12	➤ A complete and current manual consists of pages shown in the following contents section.	
Control Panel – Left Hand		Important	
♦ Layout View	14	➤ Contact the installing and/or local Bard distributor for all parts requirements. Make sure to have the complete model and serial number available from the unit rating plates.	
♦ Usage List	15, 16		
Blower Assembly			
♦ Exploded View	18		
♦ Usage List	18		
DC Freecooling			
♦ Exploded View	19		
♦ Usage List	19		



Bard Manufacturing Company, Inc.
Bryan, Ohio 43506

www.bardhvac.com

Manual: 2110-1430B
Supersedes: 2110-1430A
Date: 06-28-16

CABINET COMPONENTS - Right Hand

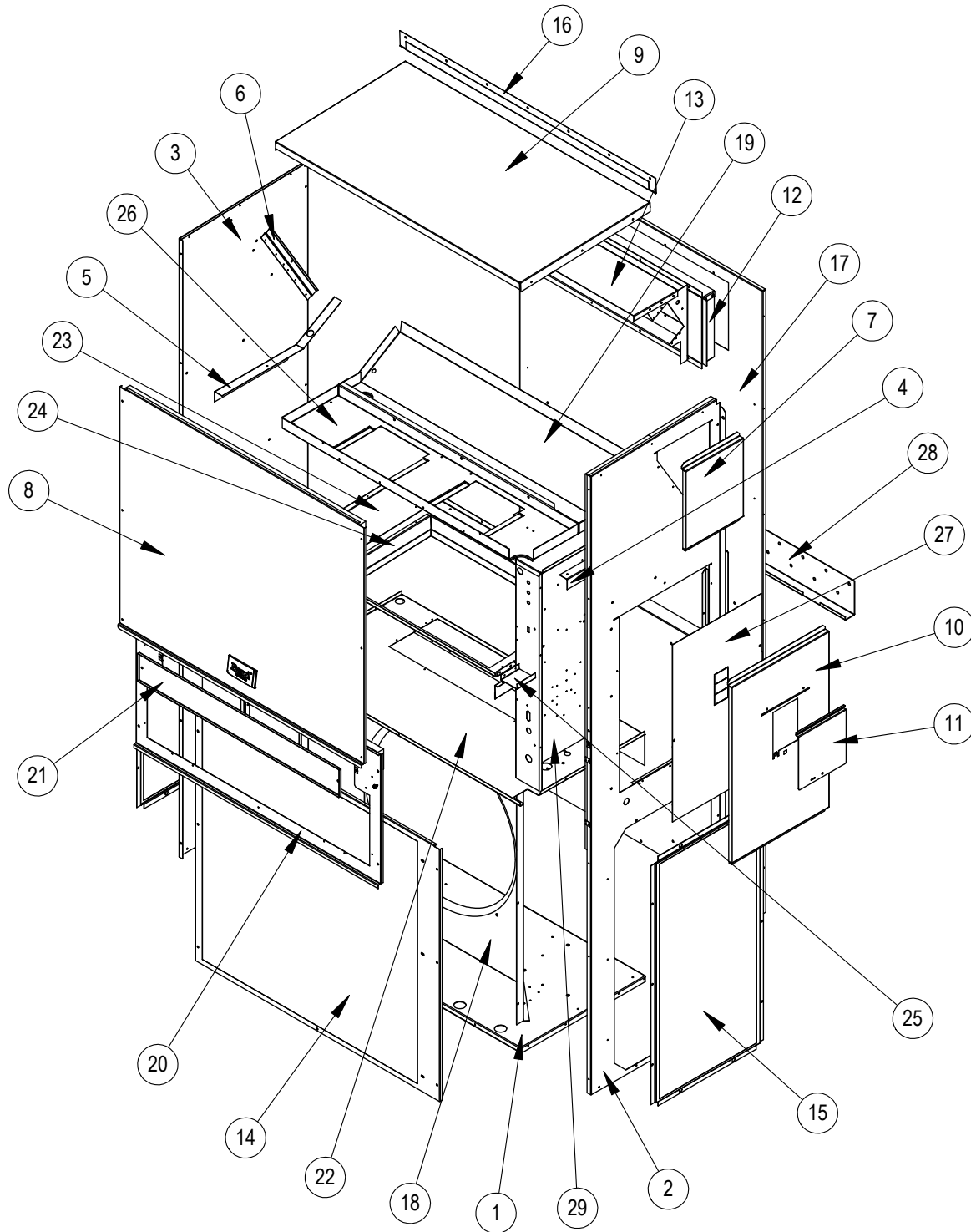

SEXP-713

CABINET COMPONENTS – Right Hand

Dwg. No.	Part Number	Description	D28A2P-A, -B	D36A2P-A, -B	D42A2P-A, -B	D48A2P-A, -B	D60A2P-A, -B
1	S127-481	Base	X	X	X	X	X
2	S501-840-* ①	Right Side	X	X	X		
2	S501-841-* ①	Right Side				X	X
3	S501-686-* ①	Left Side	X	X	X		
3	S501-733-* ①	Left Side				X	X
4	105X878	Support Angle	X	X	X	X	X
5	105X877	Support Angle	X	X	X	X	X
6	147-046	Evap. Angle	X	X	X	X	X
7	543-172-* ①	Heater Access Cover	X	X	X	X	X
8	S515-230-* ①	Upper Front	X	X	X		
8	S515-246-* ①	Upper Front				X	X
9	507-307-* ①	Top	X	X	X	X	X
10	S533-256-* ①	Control Panel Cover	X	X	X	X	X
11	S153-218-* ①	Disconnect Access Door	X	X	X	X	X
12	S111X034	Outlet Airframe Assembly	X	X	X	X	X
13	135-129	Heat Shield	X	X	X	X	X
14	118-048-* ①	Condenser Grille	X	X	X		
14	118-085-* ①	Condenser Grille				X	X
15	118-057-* ①	Side Grille	2	2	2		
15	118-086-* ①	Side Grille				2	2
16	113-150-* ①	Rain Flashing	X	X	X	X	X
17	508-098	Back	X	X	X		
17	509-251	Back				X	X
18	125-069	Fan Shroud	X	X	X		
18	125-070	Fan Shroud				X	X
19	523-144	Drain Pan Assembly	X	X	X	X	X
20	553-600-* ①	Hood Mounting Door	X	X	X	X	X
21	553-564	Filter Door	X	X	X	X	X
22	521X258	Condenser Partition	X	X	X	X	X
23	131X164	Filter Tray	X	X	X	X	X
24	131-165	Filter Tray Angle	X	X	X	X	X
25	137-209	Fill Plate	X	X	X	X	X
26	121X501	Blower Partition	X	X	X	X	X
27	S132-255	Inner Control Panel Cover	X	X	X	X	X
28	113-140	Bottom Support Bracket	X	X	X	X	X
29	Control Panel Assembly	See Control Panel Assembly Drawing & Parts List	X	X	X	X	X

① Exterior cabinet parts are manufactured with various paint color options. To ensure the proper paint color is received, reference the following codes:

Beige	-X	Buckeye Gray	-4
White	-1		

CABINET COMPONENTS - Left Hand

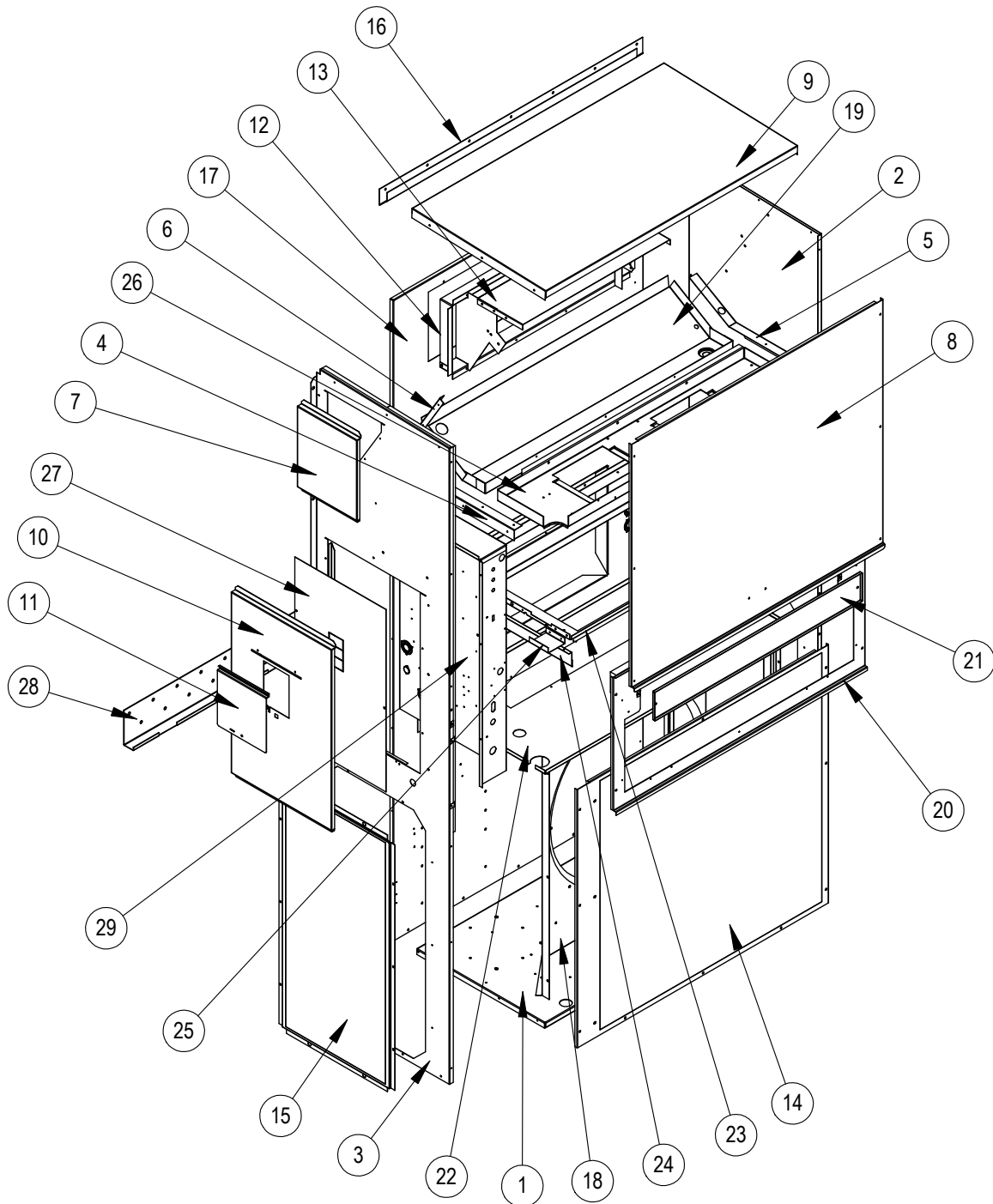

SEXP-714

CABINET COMPONENTS - Left Hand

Dwg. No.	Part Number	Description	D28L2P-A, -B	D36L2P-A, -B	D42L2P-A, -B	D48L2P-A, -B	D60L2P-A, -B
1	S127-482	Base	X	X	X	X	X
2	S501-687-* ①	Right Side	X	X	X		
2	S501-826-* ①	Right Side				X	X
3	S501-842-* ①	Left Side	X	X	X		
3	S501-843-* ①	Left Side				X	X
4	105Y878	Support Angle	X	X	X	X	X
5	105Y877	Support Angle	X	X	X	X	X
6	147-046	Evap. Angle	X	X	X	X	X
7	543-172-* ①	Heater Access Cover	X	X	X	X	X
8	S515-230-* ①	Upper Front	X	X	X		
8	S515-246-* ①	Upper Front				X	X
9	507-307-* ①	Top	X	X	X	X	X
10	S533-257-* ①	Control Panel Cover	X	X	X	X	X
11	S153-218-* ①	Disconnect Access Door	X	X	X	X	X
12	S111Y034	Outlet Airframe Assembly	X	X	X	X	X
13	135-129	Heat Shield	X	X	X	X	X
14	118-049-* ①	Condenser Grille	X	X	X		
14	118-094-* ①	Condenser Grille				X	X
15	118-057-* ①	Side Grille	2	2	2		
15	118-086-* ①	Side Grille				2	2
16	113-150-* ①	Rain Flashing	X	X	X	X	X
17	508-098	Back	X	X	X		
17	509-251	Back				X	X
18	125-069	Fan Shroud	X	X	X		
18	125-070	Fan Shroud				X	X
19	523-145	Drain Pan Assembly	X	X	X	X	X
20	553-600-* ①	Hood Mounting Door	X	X	X	X	X
21	553-564	Filter Door	X	X	X	X	X
22	521Y258	Condenser Partition	X	X	X	X	X
23	131Y164	Filter Tray	X	X	X	X	X
24	131-165	Filter Tray Angle	X	X	X	X	X
25	137-209	Fill Plate	X	X	X	X	X
26	121Y501	Blower Partition	X	X	X	X	X
27	S132-255	Inner Control Panel Cover	X	X	X	X	X
28	113-140	Bottom Support Bracket	X	X	X	X	X
29	Control Panel Assembly	See Control Panel Assembly Drawing & Parts List	X	X	X	X	X

① Exterior cabinet parts are manufactured with various paint color options. To ensure the proper paint color is received, reference the following codes:

Beige	-X	Buckeye Gray	-4
White	-1		

FUNCTIONAL COMPONENTS

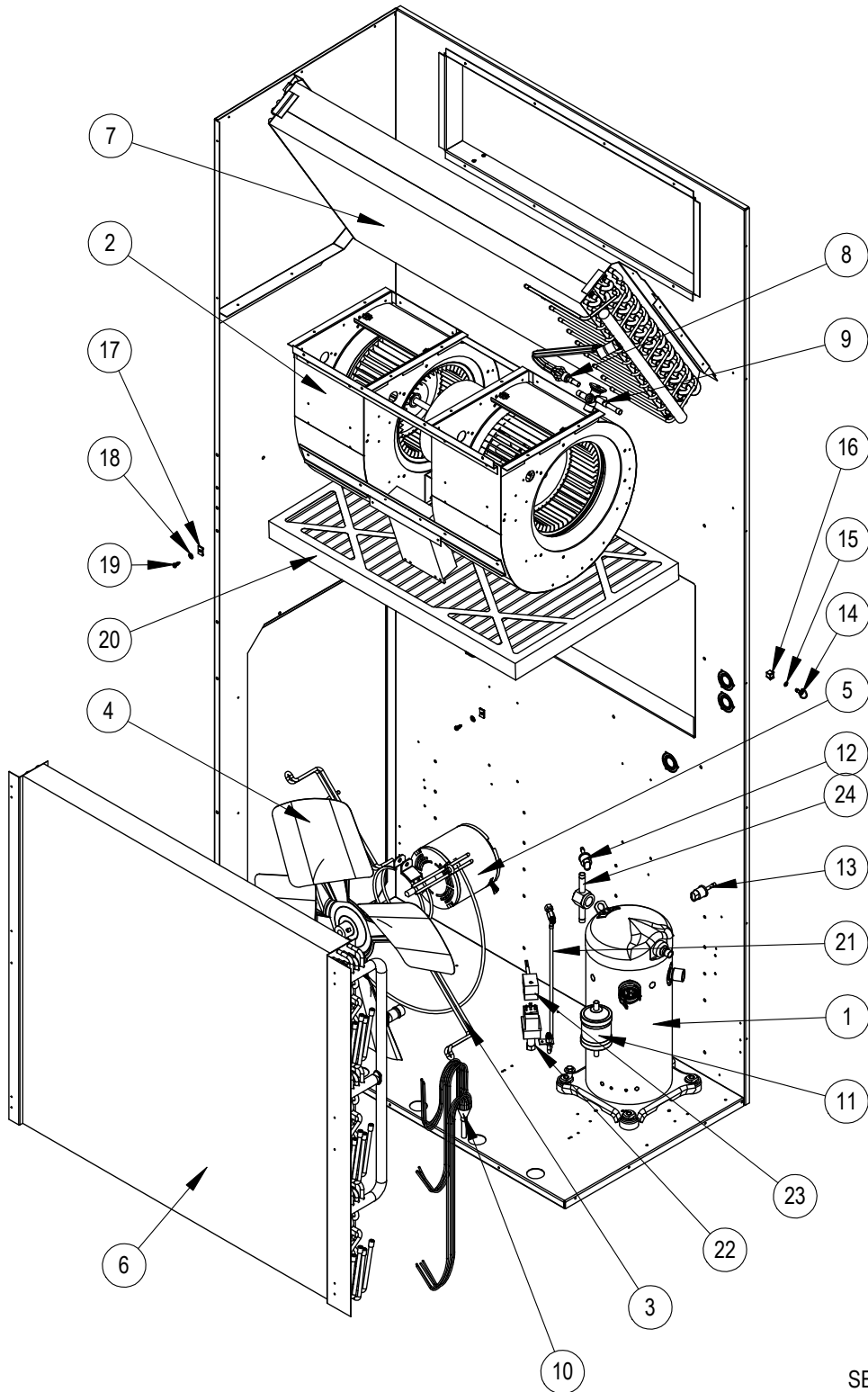

SEXP-715

This drawing is referenced in tables on pages 7 and 8

FUNCTIONAL COMPONENTS – Single Phase Units

Dwg. No.	Part Number	Description	D28A2P-A	D28L2P-A	D36A2P-A	D36L2P-A	D42A2P-A	D42L2P-A	D48A2P-A	D48L2P-A	D60A2P-A	D60L2P-A
1	8000-314	Compressor	X	X								
1	8000-278	Compressor			X	X						
1	8000-362	Compressor					X	X				
1	8000-332	Compressor							X	X		
1	8000-324	Compressor									X	X
2	S900-338	Blower Assembly	X	X	X	X	X	X	X	X	X	X
3	8200-004	Fan Motor Mount	X	X	X	X	X	X	X	X	X	X
4	5151-060	Fan Blade	X	X	X	X	X	X	X	X	X	X
5	8105-066	Condenser Motor	X	X	X	X	X	X	X	X	X	X
6	5051-107BX	Condenser Coil	X	X	X	X						
6	5051-167BX	Condenser Coil					X	X				
6	5051-193BX	Condenser Coil							X	X	X	X
7	5060-164BX	Evaporator Coil	X	X	X	X						
7	917-0184BX	Evaporator Coil					X	X				
7	917-0190BX	Evaporator Coil							X	X	X	X
8	800-0342	Cooling Distributor	X	X								
8	800-0409	Cooling Distributor			X	X						
8	800-0383	Cooling Distributor					X	X				
8	800-0415	Cooling Distributor							X	X		
8	800-0416	Cooling Distributor									X	X
9	5651-239	Expansion Valve	X	X								
10	800-0440	Heating Distributor			X							
10	800-0441	Heating Distributor				X						
10	800-0444	Heating Distributor					X					
10	800-0445	Heating Distributor						X				
10	800-0439	Heating Distributor							X		X	
10	800-0438	Heating Distributor								X		X
11	5201-022	Filter Drier	X	X	X	X	X	X	X	X	X	X
12	1804-0462	High Pressure Switch (Flare)	X	X	X	X	X	X	X	X	X	X
13	1804-0386	Low Pressure Switch (Flare)	X	X	X	X	X	X	X	X	X	X
14	1171-022	1/4" Turn Fastener	X	X	X	X	X	X	X	X	X	X
15	1171-024	1/4" Retainer Clip	X	X	X	X	X	X	X	X	X	X
16	1171-023	1/4" Receptacle	X	X	X	X	X	X	X	X	X	X
17	1171-028	No. 9 Clip on Receptacle	2	2	2	2	2	2	2	2	2	2
18	1171-027	No. 9 Retainer Clip	2	2	2	2	2	2	2	2	2	2
19	1171-057	No. 9 Captive Screw Fastener	2	2	2	2	2	2	2	2	2	2
20	7004-027	Air Filter 2" Pleated MERV 8 ①	X	X	X	X	X	X	X	X	X	X
20	7004-049	Air Filter 2" Pleated MERV 11 ①	X	X	X	X	X	X	X	X	X	X
21	1804-0541	Low Ambient Control Extension Tube			X		X		X		X	
21	1804-0544	Low Ambient Control Extension Tube				X		X		X		X
22	8612-027	230V Head Pressure Control			X	X	X	X	X	X	X	X
23	8611-115	Plug & Wire Assembly			X	X	X	X	X	X	X	X
24	5201-014	Sight Glass	X	X	X	X	X	X	X	X	X	X
NS	3000-1222	Compressor Power Plug	X	X	X	X	X	X	X	X	X	X
NS	8605-019	Crankcase Heater ①	X	X	X	X	X					
NS	8605-015	Crankcase Heater ①						X	X		X	X
NS	8301-056	Temperature/Humidity Sensor	X	X	X	X	X	X	X	X	X	X
NS	3020-005	Wire Assembly to Outdoor Sensor	X	X	X	X	X	X	X	X	X	X

NS – Not Shown

① – Optional

FUNCTIONAL COMPONENTS – Three Phase Units

Dwg. No.	Part Number	Description	D28A2P-B	D28L2P-B	D36A2P-B	D36L2P-B	D42A2P-B	D42L2P-B	D48A2P-B	D48L2P-B	D60A2P-B	D60L2P-B
1	8000-315	Compressor	X	X								
1	8000-283	Compressor			X	X						
1	8000-363	Compressor					X	X				
1	8000-333	Compressor							X	X		
1	8000-325	Compressor									X	X
2	S900-338	Blower Assembly	X	X	X	X	X	X	X	X	X	X
3	8200-004	Fan Motor Mount	X	X	X	X	X	X	X	X	X	X
4	5151-060	Fan Blade	X	X	X	X	X	X	X	X	X	X
5	8105-066	Condenser Motor	X	X	X	X	X	X	X	X	X	X
6	5051-107BX	Condenser Coil	X	X	X	X						
6	5051-167BX	Condenser Coil					X	X				
6	5051-193BX	Condenser Coil							X	X	X	X
7	5060-164BX	Evaporator Coil	X	X	X	X						
7	917-0184BX	Evaporator Coil					X	X				
7	917-0190BX	Evaporator Coil							X	X	X	X
8	800-0342	Cooling Distributor	X	X								
8	800-0409	Cooling Distributor			X	X						
8	800-0383	Cooling Distributor					X	X				
8	800-0415	Cooling Distributor							X	X		
8	800-0416	Cooling Distributor									X	X
9	5651-239	Expansion Valve	X	X								
10	800-0440	Heating Distributor			X							
10	800-0441	Heating Distributor				X						
10	800-0444	Heating Distributor					X					
10	800-0445	Heating Distributor						X				
10	800-0439	Heating Distributor							X		X	
10	800-0438	Heating Distributor								X		X
11	5201-022	Filter Drier	X	X	X	X	X	X	X	X	X	X
12	1804-0462	High Pressure Switch (Flare)	X	X	X	X	X	X	X	X	X	X
13	1804-0386	Low Pressure Switch (Flare)	X	X	X	X	X	X	X	X	X	X
14	1171-022	1/4" Turn Fastener	X	X	X	X	X	X	X	X	X	X
15	1171-024	1/4" Retainer Clip	X	X	X	X	X	X	X	X	X	X
16	1171-023	1/4" Receptacle	X	X	X	X	X	X	X	X	X	X
17	1171-028	No. 9 Clip on Receptacle	2	2	2	2	2	2	2	2	2	2
18	1171-027	No. 9 Retainer Clip	2	2	2	2	2	2	2	2	2	2
19	1171-057	No. 9 Captive Screw Fastener	2	2	2	2	2	2	2	2	2	2
20	7004-027	Air Filter 2" Pleated MERV 8 ①	X	X	X	X	X	X	X	X	X	X
20	7004-049	Air Filter 2" Pleated MERV 11 ①	X	X	X	X	X	X	X	X	X	X
21	1804-0541	Low Ambient Control Extension Tube			X		X		X		X	
21	1804-0544	Low Ambient Control Extension Tube				X		X		X		X
22	8612-027	230V Head Pressure Control			X	X	X	X	X	X	X	X
23	8611-115	Plug & Wire Assembly			X	X	X	X	X	X	X	X
24	5201-014	Sight Glass	X	X	X	X	X	X	X	X	X	X
NS	3000-1230	Compressor Power Plug	X	X	X	X	X	X	X	X	X	X
NS	8605-019	Crankcase Heater ①	X	X	X	X	X					
NS	8605-015	Crankcase Heater ①						X	X	X	X	
NS	8301-056	Temperature/Humidity Sensor	X	X	X	X	X	X	X	X	X	X
NS	3020-005	Wire Assembly to Outdoor Sensor	X	X	X	X	X	X	X	X	X	X

NS – Not Shown

① – Optional

This table references the drawing on page 6

This page intentionally left blank

CONTROL PANEL - Right Hand

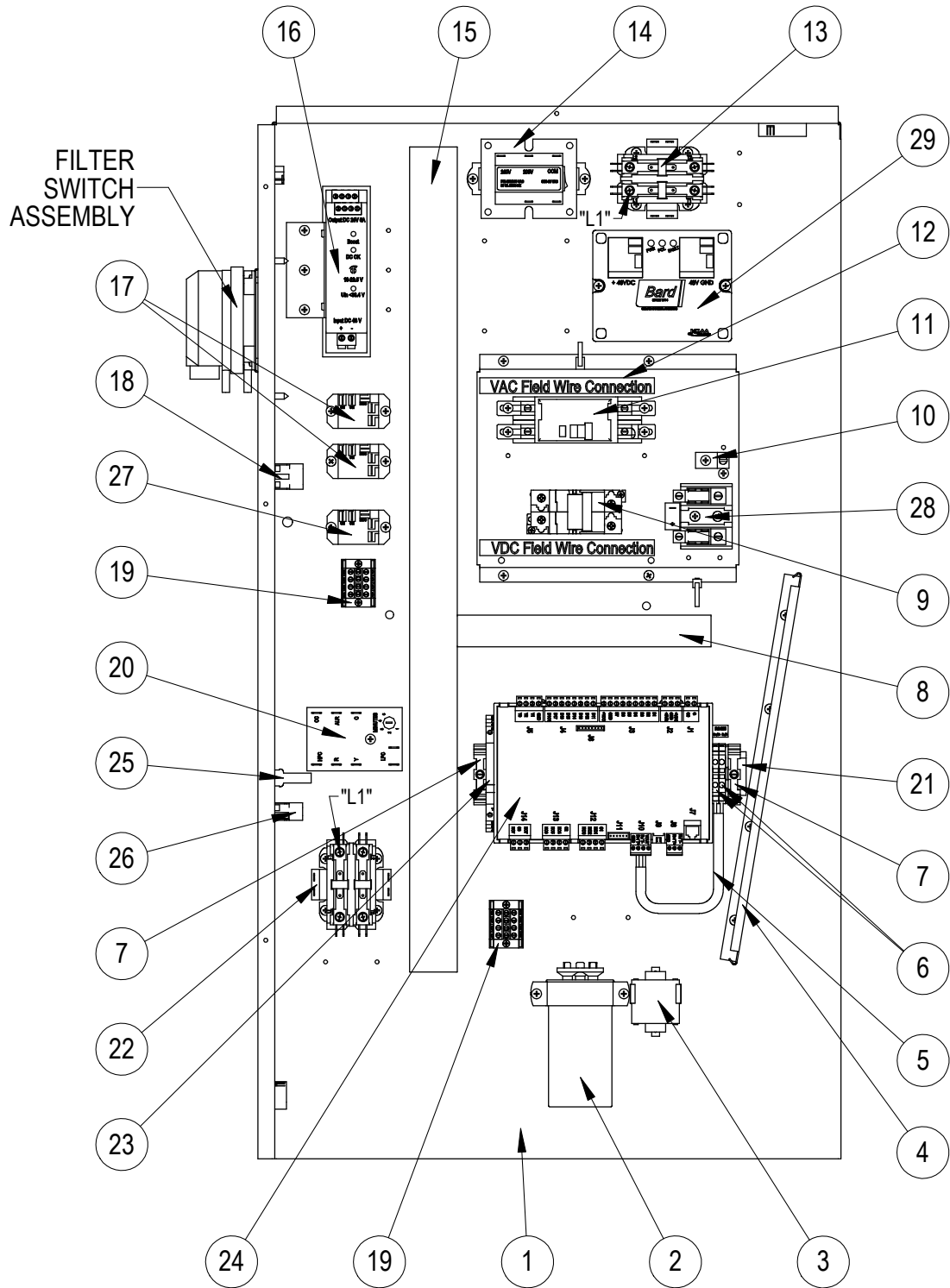

SEXP-750

This drawing is referenced in tables on pages 11 and 12

CONTROL PANEL – Right Hand, Single Phase Units

Dwg. No.	Part Number	Description	D28AP2-A05	D36AP2-A05	D42A2P-A05	D48A2P-A05	D60A2P-A05
1	517X357	Control Panel	X	X	X	X	X
2	8552-080	Capacitor 40/10 MFD 370V	X				
2	8552-079	Capacitor 45/10 MFD 370V		X	X		
2	8552-089	Capacitor 70/10 MFD 370V				X	
2	8552-058	Capacitor 80/10 MFD 440V					X
3	8551-004	Motor Starting Device	X	X	X	X	X
4	135-122	Wire Shield	X	X	X	X	X
5	3020-004	12" 2 Conductor Shielded Cable	X	X	X	X	X
6	8611-150	Terminal Block for DIN Rail RS485	X	X	X	X	X
7	8611-144	End Clamp for DIN Rail	X	X	X	X	X
8	8611-140-0800	1-1/2" x 1" Cable Duct x 8"	X	X	X	X	X
9	8615-079	Circuit Breaker 20A 125 VDC	X	X	X	X	X
10	8611-006	Ground Terminal	X	X	X	X	X
11	8615-055	Circuit Breaker 40A 2-Pole	X	X	X	X	
11	8615-041	Circuit Breaker 60A 2-Pole					X
12	8615-057	Circuit Breaker Mounting Foot	X	X	X	X	X
13	8401-006	Contacto 2-Pole 20 Amp	1	1	1	1	1
14	8407-048	Transformer 208/240-24-75VA	X	X	X	X	X
15	8611-139-2600	1-1/2" x 1-1/2" Cable Duct 26"	X	X	X	X	X
16	8301-050	48VDC to 24VDC Converter 5 Amps	X	X	X	X	X
17	8201-130	Compressor and Power Loss SPDT Relays	2	2	2	2	2
18	3000-1471	Wire Assembly	X	X	X	X	X
19	8607-037	Terminal Block 4 Position	2	2	2	2	2
20	8201-088	Compressor Control Module	X	X	X	X	X
21	8611-145	35mm DIN Rail 8-1/2"	X	X	X	X	X
22	8401-034	Contacto 2-Pole 40 Amp	X	X	X	X	X
23	8201-153	3-Way Isolation Relay 0-10VDC	1	1	1	1	1
24	8301-051-003	Micro PC - Small	X	X	X	X	X
25	3000-1470	Vent Motor Plug	X	X	X	X	X
26	3000-1472	Blade Switch and Return Air Sensor	X	X	X	X	X
27	8201-151	Blower Motor Start Relay SPDT 24VDC Coil	X	X	X	X	X
28	8607-013	Terminal Block	X	X	X	X	X
29	8201-156	DC Polarity-Voltage Monitor	X	X	X	X	X
NS	910-1946	Filter Switch Assembly	X	X	X	X	X
NS	4206-106	Unit Wiring Diagram	X	X	X	X	X

NS – Not Shown

CONTROL PANEL – Right Hand, Three Phase Units

Dwg. No.	Part Number	Description	D28AP2-B06	D36AP2-B06	D42A2P-B06	D48A2P-B06	D60A2P-B06
1	517X357	Control Panel	X	X	X	X	X
2	8552-005	Capacitor 40/10 MFD 370V	X	X	X	X	X
3	8551-004	Motor Starting Device	X	X	X	X	X
4	135-122	Wire Shield	X	X	X	X	X
5	3020-004	12" 2 Conductor Shielded Cable	X	X	X	X	X
6	8611-150	Terminal Block for DIN Rail RS485	X	X	X	X	X
7	8611-144	End Clamp for DIN Rail	X	X	X	X	X
8	8611-140-0800	1-1/2" x 1" Cable Duct x 8"	X	X	X	X	X
9	8615-079	Circuit Breaker 20A 125 VDC	X	X	X	X	X
10	8611-006	Ground Terminal	X	X	X	X	X
11	8615-054	Circuit Breaker 20A 3-Pole	X				
11	8615-044	Circuit Breaker 45A 3-Pole		X	X		
11	8615-045	Circuit Breaker 50A 3-Pole				X	
11	8615-046	Circuit Breaker 60A 3-Pole					X
12	8615-057	Circuit Breaker Mounting Foot	X	X	X	X	X
13	8401-002	Contactora 3-Pole 20 Amp	1	1	1	1	1
14	8407-048	Transformer 208/240-24-75VA	X	X	X	X	X
15	8611-139-2600	1-1/2" x 1-1/2" Cable Duct 26"	X	X	X	X	X
16	8301-050	48VDC to 24VDC Converter 5 Amps	X	X	X	X	X
17	8201-130	Compressor and Power Loss SPDT Relays	2	2	2	2	2
18	3000-1471	Wire Assembly	X	X	X	X	X
19	8607-037	Terminal Block 4 Position	2	2	2	2	2
20	8201-088	Compressor Control Module	X	X	X	X	X
21	8611-145	35mm DIN Rail 8-1/2"	X	X	X	X	X
22	8401-035	Contactora 3-Pole 40 Amp	X	X	X	X	X
23	8201-153	3-Way Isolation Relay 0-10VDC	1	1	1	1	1
24	8301-051-003	Micro PC - Small	X	X	X	X	X
25	3000-1470	Vent Motor Plug	X	X	X	X	X
26	3000-1472	Blade Switch and Return Air Sensor	X	X	X	X	X
27	8201-151	Blower Motor Start Relay SPDT 24VDC Coil	X	X	X	X	X
28	8607-013	Terminal Block	X	X	X	X	X
29	8201-156	DC Polarity-Voltage Monitor	X	X	X	X	X
NS	910-1946	Filter Switch Assembly	X	X	X	X	X
NS	4206-106	Unit Wiring Diagram	X	X	X	X	X
NS	8201-126	Phase Monitor	X	X	X	X	X

NS – Not Shown

This table references the drawing on page 10

This page intentionally left blank

CONTROL PANEL - Left Hand

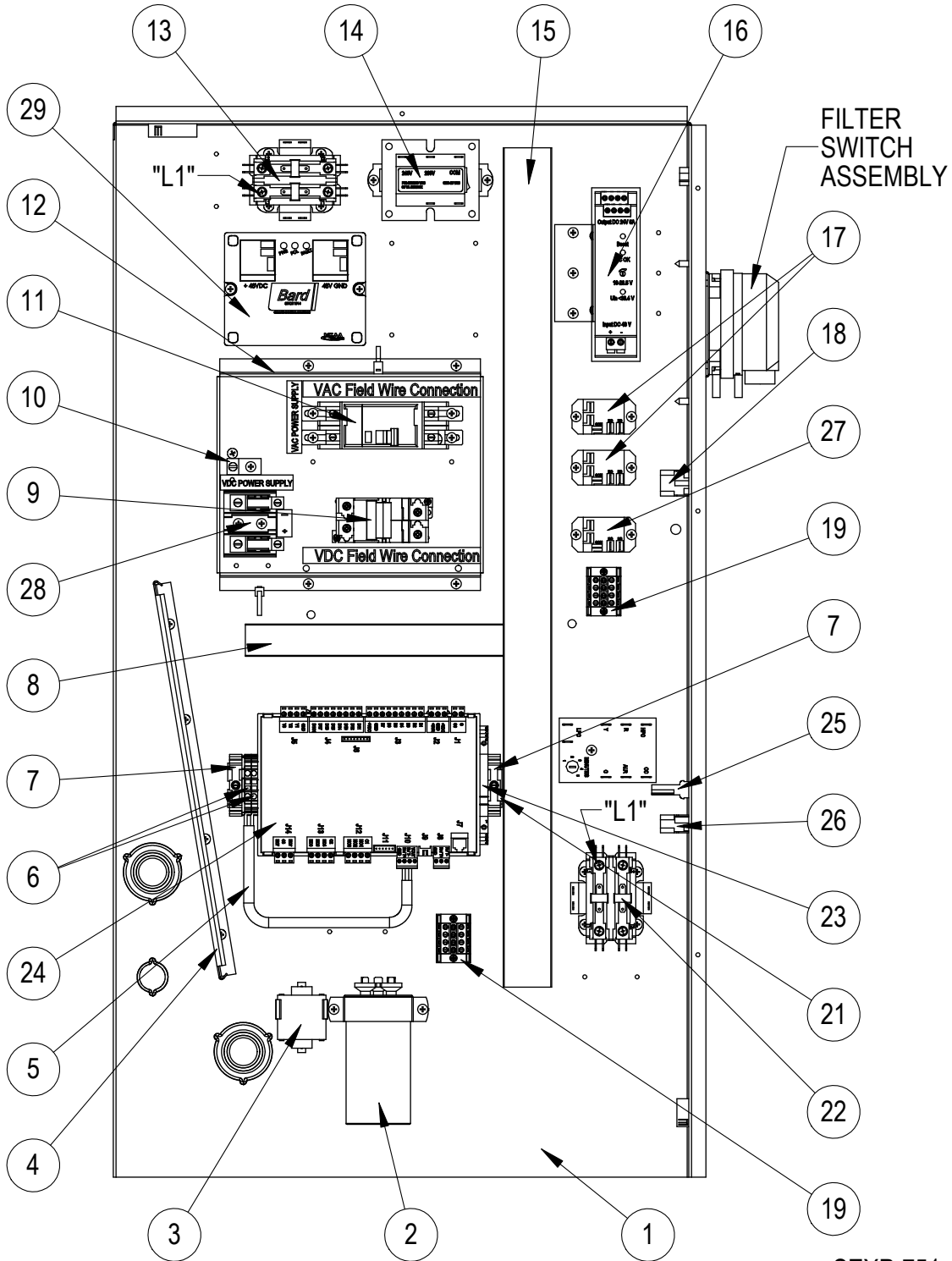

This drawing is referenced in tables on pages 15 and 16

CONTROL PANEL – Left Hand, Single Phase Units

Dwg. No.	Part Number	Description	D28L2P-A05	D36L2P-A05	D42L2P-A05	D48L2P-A05	D60L2P-A05
1	517Y357	Control Panel	X	X	X	X	X
2	8552-080	Capacitor 40/10 MFD 370V	X				
2	8552-079	Capacitor 45/10 MFD 370V		X	X		
2	8552-089	Capacitor 70/10 MFD 370V				X	
2	8552-058	Capacitor 80/10 MFD 440V					X
3	8551-004	Motor Starting Device	X	X	X	X	X
4	135-122	Wire Shield	X	X	X	X	X
5	3020-004	12" 2 Conductor Shielded Cable	X	X	X	X	X
6	8611-150	Terminal Block for DIN Rail RS485	X	X	X	X	X
7	8611-144	End Clamp for DIN Rail	X	X	X	X	X
8	8611-140-0800	1-1/2" x 1" Cable Duct x 8"	X	X	X	X	X
9	8615-079	Circuit Breaker 20A 125 VDC	X	X	X	X	X
10	8611-006	Ground Terminal	X	X	X	X	X
11	8615-055	Circuit Breaker 40A 2-Pole	X	X	X	X	
11	8615-041	Circuit Breaker 60A 2-Pole					X
12	8615-057	Circuit Breaker Mounting Foot	X	X	X	X	X
13	8401-006	Contactors 2-Pole 20 Amp	1	1	1	1	1
14	8407-048	Transformer 208/240-24-75VA	X	X	X	X	X
15	8611-139-2600	1-1/2" x 1-1/2" Cable Duct 26"	X	X	X	X	X
16	8301-050	48VDC to 24VDC Converter 5 Amps	X	X	X	X	X
17	8201-130	Compressor and Power Loss SPDT Relays	2	2	2	2	2
18	3000-1471	Wire Assembly	X	X	X	X	X
19	8607-037	Terminal Block 4 Position	2	2	2	2	2
20	8201-088	Compressor Control Module	X	X	X	X	X
21	8611-145	35mm DIN Rail 8-1/2"	X	X	X	X	X
22	8401-034	Contactors 2-Pole 40 Amp	X	X	X	X	X
23	8201-153	3-Way Isolation Relay 0-10VDC	1	1	1	1	1
24	8301-051-003	Micro PC - Small	X	X	X	X	X
25	3000-1470	Vent Motor Plug	X	X	X	X	X
26	3000-1472	Blade Switch and Return Air Sensor	X	X	X	X	X
27	8201-151	Blower Motor Start Relay SPDT 24VDC Coil	X	X	X	X	X
28	8607-013	Terminal Block	X	X	X	X	X
29	8201-156	DC Polarity-Voltage Monitor	X	X	X	X	X
NS	910-1946	Filter Switch Assembly	X	X	X	X	X
NS	4206-106	Unit Wiring Diagram	X	X	X	X	X

NS – Not Shown

CONTROL PANEL – Left Hand, Three Phase Units

Dwg. No.	Part Number	Description	D28LP2-B06	D36LP2-B06	D42LP2-B06	D48LP2-B06	D60LP2-B06
1	517Y357	Control Panel	X	X	X	X	X
2	8552-005	Capacitor 40/10 MFD 370V	X	X	X	X	X
3	8551-004	Motor Starting Device	X	X	X	X	X
4	135-122	Wire Shield	X	X	X	X	X
5	3020-004	12" 2 Conductor Shielded Cable	X	X	X	X	X
6	8611-150	Terminal Block for DIN Rail RS485	X	X	X	X	X
7	8611-144	End Clamp for DIN Rail	X	X	X	X	X
8	8611-140-0800	1-1/2" x 1" Cable Duct x 8"	X	X	X	X	X
9	8615-079	Circuit Breaker 20A 125 VDC	X	X	X	X	X
10	8611-006	Ground Terminal	X	X	X	X	X
11	8615-054	Circuit Breaker 20A 3-Pole	X				
11	8615-044	Circuit Breaker 45A 3-Pole		X	X		
11	8615-045	Circuit Breaker 50A 3-Pole				X	
11	8615-046	Circuit Breaker 60A 3-Pole					X
12	8615-057	Circuit Breaker Mounting Foot	X	X	X	X	X
13	8401-002	Contactors 3-Pole 20 Amp	1	1	1	1	1
14	8407-048	Transformer 208/240-24-75VA	X	X	X	X	X
15	8611-139-2600	1-1/2" x 1-1/2" Cable Duct 26"	X	X	X	X	X
16	8301-050	48VDC to 24VDC Converter 5 Amps	X	X	X	X	X
17	8201-130	Compressor and Power Loss SPDT Relays	2	2	2	2	2
18	3000-1471	Wire Assembly	X	X	X	X	X
19	8607-037	Terminal Block 4 Position	2	2	2	2	2
20	8201-148	Compressor Control Module	X	X	X	X	X
21	8611-145	35mm DIN Rail 8-1/2"	X	X	X	X	X
22	8401-035	Contactors 3-Pole 40 Amp	X	X	X	X	X
23	8201-153	3-Way Isolation Relay 0-10VDC	1	1	1	1	1
24	8301-051-003	Micro PC - Small	X	X	X	X	X
25	3000-1470	Vent Motor Plug	X	X	X	X	X
26	3000-1472	Blade Switch and Return Air Sensor	X	X	X	X	X
27	8201-151	Blower Motor Start Relay SPDT 24VDC Coil	X	X	X	X	X
28	8607-013	Terminal Block	X	X	X	X	X
29	8201-156	DC Polarity-Voltage Monitor	X	X	X	X	X
NS	910-1946	Filter Switch Assembly	X	X	X	X	X
NS	4206-106	Unit Wiring Diagram	X	X	X	X	X
NS	8201-126	Phase Monitor	X	X	X	X	X

NS – Not Shown

This table references the drawing on page 14

This page intentionally left blank

BLOWER ASSEMBLY

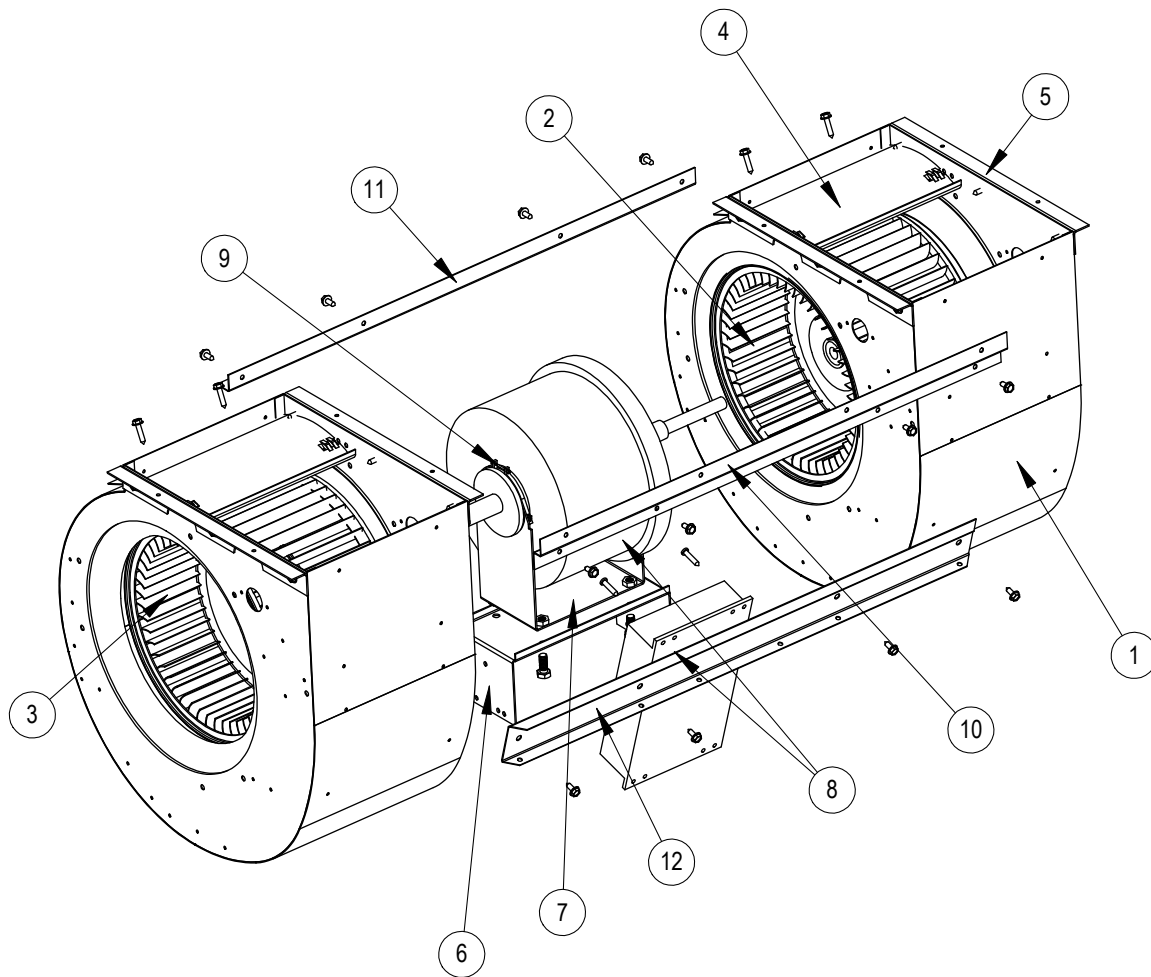

SEXP-718 A

Dwg. No.	Part Number	Description	S900-338
1	151-117	Blower Housing	2
2	5152-072	Blower Wheel	X
3	5152-096	Blower Wheel	X
4	144-167	Diffuser	2
5	105-880	Blower Angle	4
6	129-024	Cradle Support	1
7	129-022	Cradle Motor Mount	X
8	8107-021	3/4 HP Motor	X
8	8107-022	Motor Controller	X
9	8200-018	Motor Mount Latch	2
10	103-514	Hold In Offset	X
11	105-1332	Rear Blower Angle	X
12	113-518	Motor Controller Mount	X

DC FREE COOLING

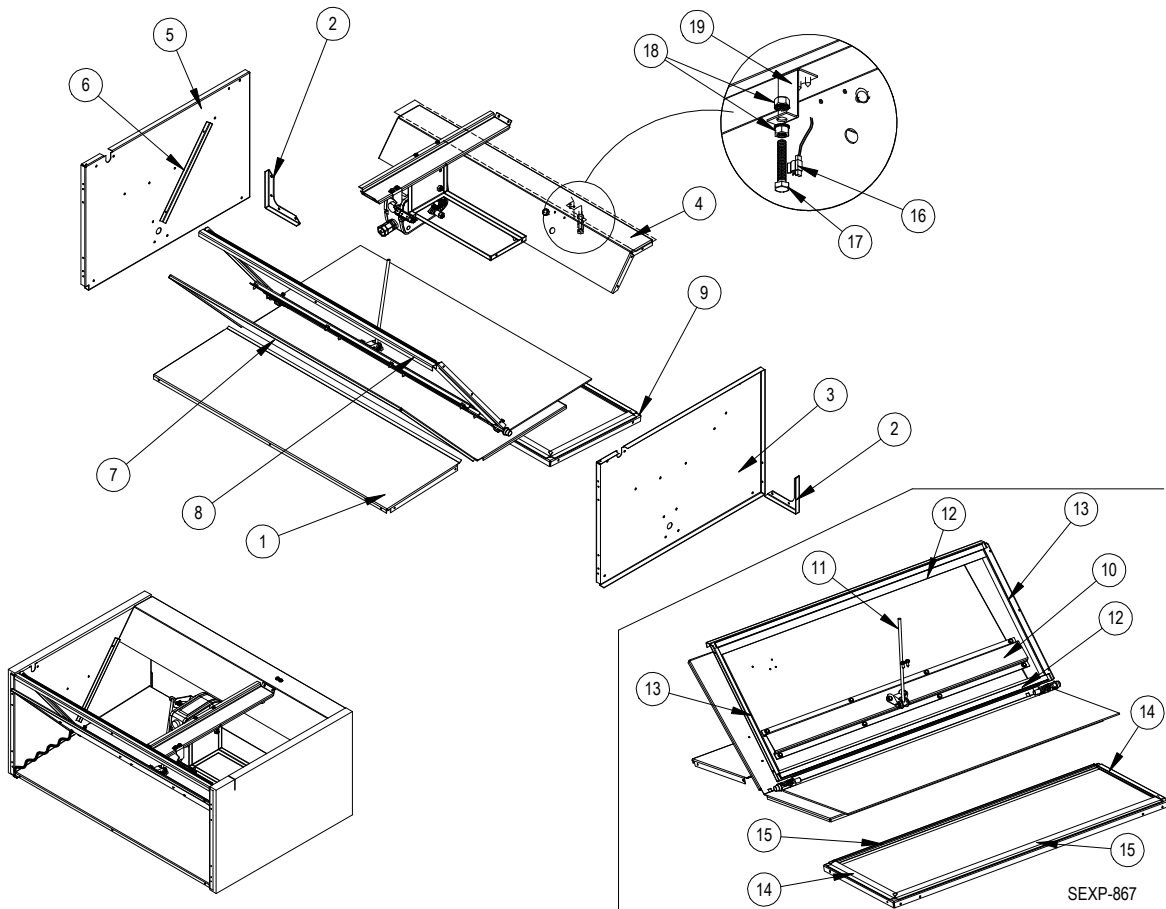

Dwg. No.	Part Number	Description
1	137-734	Lower Front Partition
2	113-526	Corner Bracket
3	S101X981	Right Side
4	S137-871	Upper Rear Partition
5	S101Y981	Left Side
6	S105-1341	Blade Seal Angle
7	S139-323	Blade
8	S137-870	Upper Front Partition
9	S137-736	Lower Rear Partition
10	141-426	Blade Support
11	8602-077	1/4 x 9" Rod
12	1921-067-2909	29-9/16" Damper Blade Seal
13	1921-067-1300	13" Damper Blade Seal
14	1921-067-1011	10-11/16" Damper Blade Seal
15	1921-067-2906	29-3/8" Damper Blade Seal
16	8408-044	Defrost Support 10K Ohm Curve J w/ 5/16" Clip
17	1012-052	Hex Head Bolt 5/16 - 18x1-3/4" 0.0005 Zinc w/ Yellow Chromate
18	1012-210	5/16" Nut 0.0005 Zinc w/ Yellow Chromate
19	113-541	Sensor Bracket

DC FREE COOLING AIR HOOD

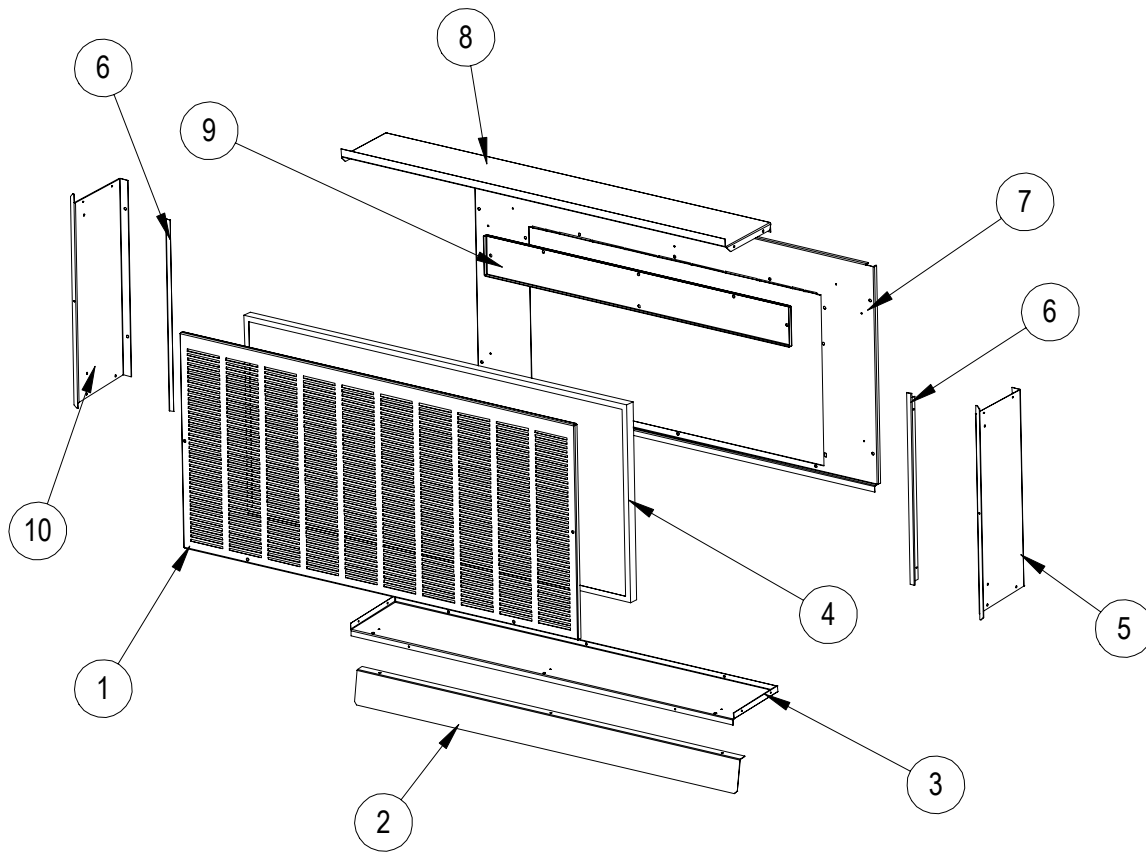

SEXP-752A

1	115-283-* ①	Hooded Front Door
2	113-484-* ①	Bottom Divider Bracket
3	S127-489-* ①	Hood Bottom
4	7003-062	Mist Filter 40-1/4" x 17-7/8" x 7/8"
5	S101-870-* ①	Right Side
6	105-1342	Side Filter Angle
7	553-600-* ①	Hood Mounting Door
8	S107-344-* ①	Hood Top
9	553-641	Filter Door
10	S101-860-* ①	Left Side
	S920-0261	Complete Hood Assembly - Beige
	S920-0262	Complete Hood Assembly - White
	S920-0263	Complete Hood Assembly - Buckeye Gray

① Exterior cabinet parts are manufactured with various paint color options.
To ensure the proper paint color is received, reference the following codes:

Beige	-X	Buckeye Gray	-4
White	-1		

DC FREE COOLING DAMPER MOTOR

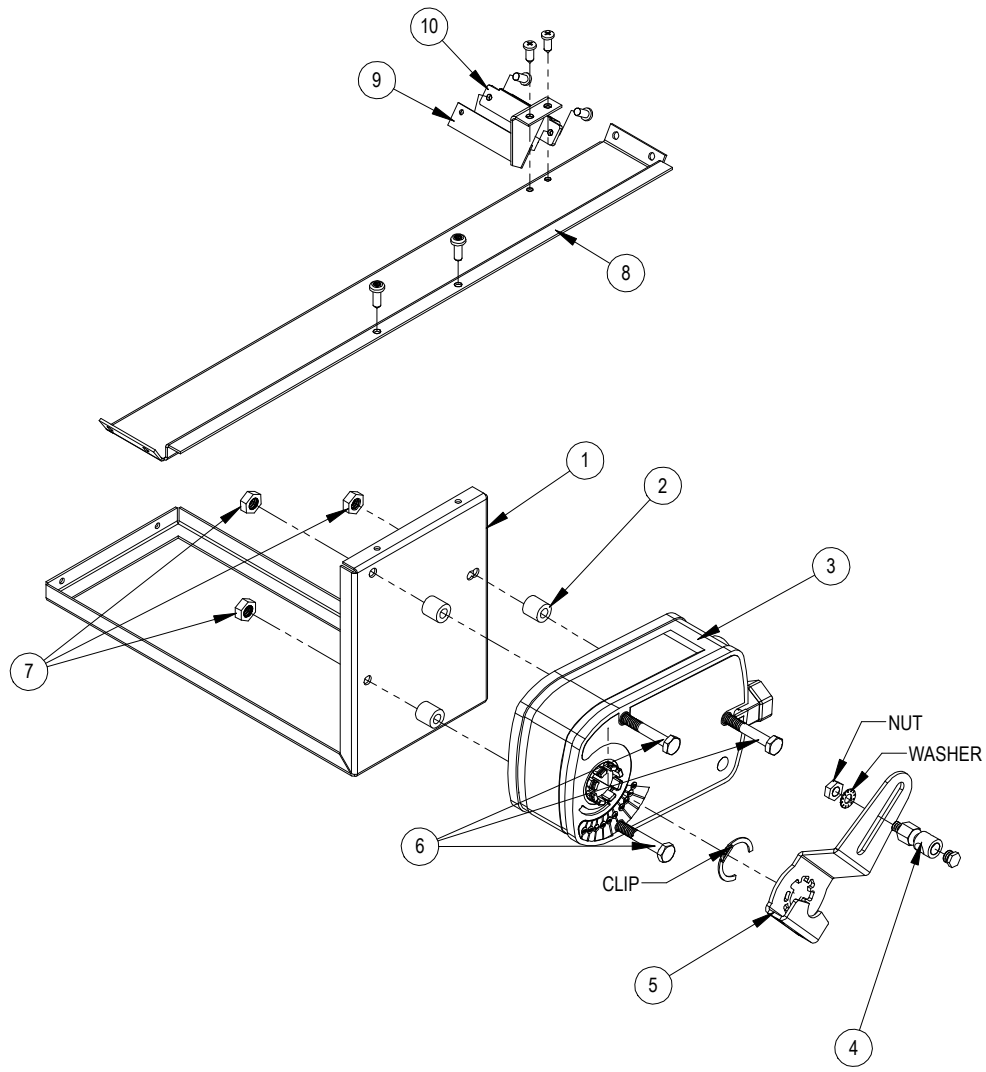

SEXP-868

1	141-467	Actuator Support Plate
2	5451-029	Nylon Sleeve 0.257" ID x 0.5" Long
3	8602-075	Direct Coupled Actuator
4	8602-008	Ball Joint
5	8602-078	Belimo Actuator Crank Arm 1/2"
6	1012-174	1/4" - 20x3 - 1/4 Hex Cap Screws
7	1012-201	1/4-20 Steel Keps Hex Nut Zinc
8	141-468	Actuator Support Bar
9	113-655	Blade Switch Bracket
10	8406-150	Lever Switch SPDT Sealed Pilot Duty
11	1012-178	4-40 x 5/8" Phillips Pan Head Machine Screw, Zinc Plated
12	1012-231	4-40 Steel Keps Hex Nut Zinc

BARD-LINK™ PLC LEAD/LAG CONTROLLER

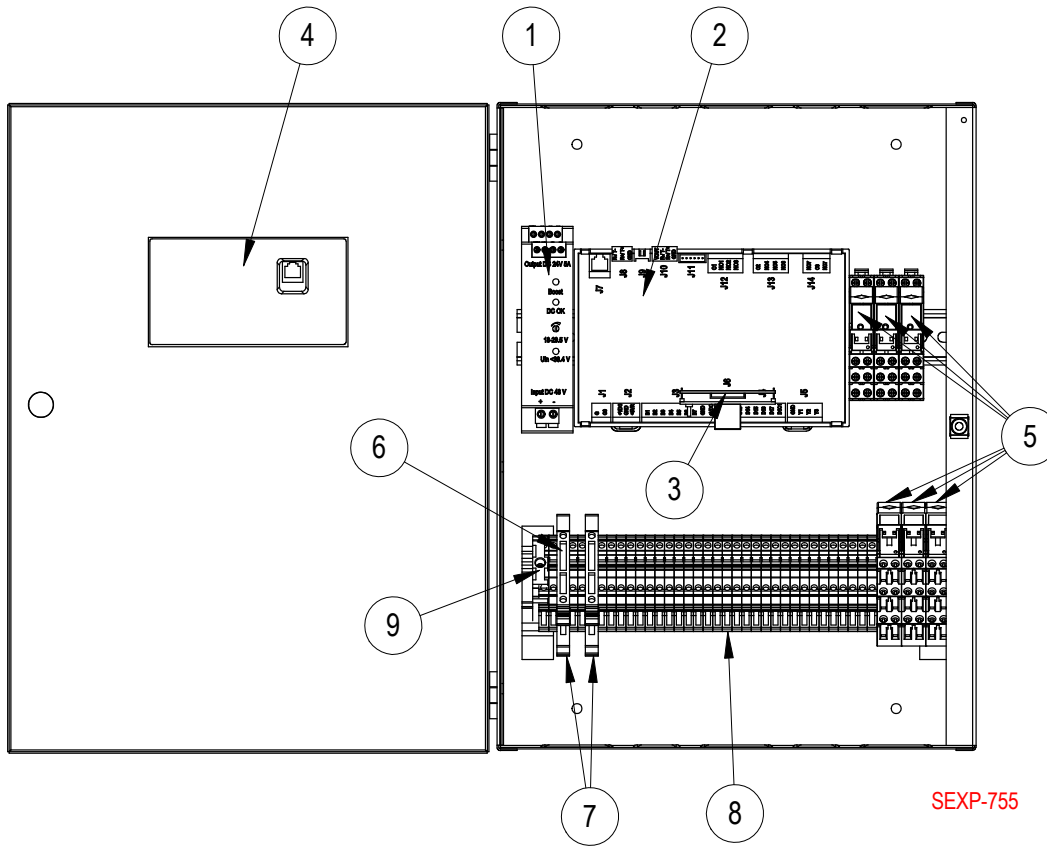

Dwg. No.	Part Number	Description	LC1000	LC1500	LC2000
1	8301-050	48VDC to 24VDC Converter 5 Amps	X	X	
2	8301-051-001	Micro PC – Small, programmed for LC1000/LC1500	X	X	
2	8301-051-005	Micro PC – Small, programmed for LC2000			X
3	8301-052	Web Card (Ethernet 1BaseT card for SNMP, FTP, HTTP, DHCP, DNS, BACnet over IP and BACnet Ethernet)	X	X	X
4	8301-053	Panel mounting display flush, pGDEvolution 132x64, black buttons with cable	X	X	X
5	8201-154	24VDC Isolation Relay, DPDT	6	6	6
6	8614-055	2.5 Amp Fuse	2	2	2
7	8607-039	Fused Terminal Block	2	2	2
8	8607-038	Terminal Block	32	32	32
9	8611-144	End Clamp (for din rail)	2	2	2
NS	8301-055	EMI Ferrite Filter	2	2	2
NS	8301-058	Remote Temperature Sensor*	X	X	X
NS	8403-079	Remote Temperature/Humidity Sensor	X	X	X
NS	8611-181	Umbilical Cord for Punch-Down Alarm Block		X	
NS	8607-040	66 Punch-Down Alarm Block		X	
NS	8301-060	Smoke Detector		X	
NS	8301-061	Hydrogen Detector*		X	
NS	8301-059	TEC-EYE™ (Service Tool), 5 ft. telephone cable	X	X	X

NS – Not Shown

* Optional