

---

# REPLACEMENT PARTS MANUAL

---

## DC FREE COOLING UNIT SYSTEM

### AIR CONDITIONER MODELS

D28A2PA	D36A2PA	D42A2PA	D48A2PA	D60A2PA
D28A2PB	D36A2PB	D42A2PB	D48A2PB	D60A2PB
D28L2PA	D36L2PA	D42L2PA	D48L2PA	D60L2PA
D28L2PB	D36L2PB	D42L2PB	D48L2PB	D60L2PB

### CONTROLLER MODELS

LC1000 LC1500 LC2000

---

<u>Description</u>	<u>Page</u>	<u>Description</u>	<u>Page</u>
Cabinet Components – Right Hand		DC Freecooling Air Hood	
♦ Exploded View .....	2	♦ Exploded View .....	20
♦ Usage List .....	3	♦ Usage List .....	20
Cabinet Components – Left Hand		DC Freecooling Damper Motor	
♦ Exploded View .....	4	♦ Exploded View .....	21
♦ Usage List .....	5	♦ Usage List .....	21
Functional Components		Bard-Link™ PLC Lead/Lag Controller	
♦ Exploded View .....	6	♦ Layout View .....	22
♦ Usage List .....	7, 8	♦ Usage List .....	22
Control Panel – Right Hand		<b>General Notes</b>	
♦ Layout View .....	10	➤ Revised and/or additional pages may be issued	
♦ Usage List .....	11, 12	from time to time.	
Control Panel – Left Hand		➤ A complete and current manual consists of pages	
♦ Layout View .....	14	shown in the following contents section.	
♦ Usage List .....	15, 16	<b>Important</b>	
Blower Assembly		➤ Contact the installing and/or local Bard distributor	
♦ Exploded View .....	18	for all parts requirements. Make sure to have the	
♦ Usage List .....	18	complete model and serial number available from	
DC Freecooling		the unit rating plates.	
♦ Exploded View .....	19		
♦ Usage List .....	19		

---



Bard Manufacturing Company, Inc.  
Bryan, Ohio 43506

[www.bardhvac.com](http://www.bardhvac.com)

Manual: 2110-1430D  
Supersedes: 2110-1430C  
Date: 6-17-19  
**REVISED: 5-26-22**

# CABINET COMPONENTS - Right Hand

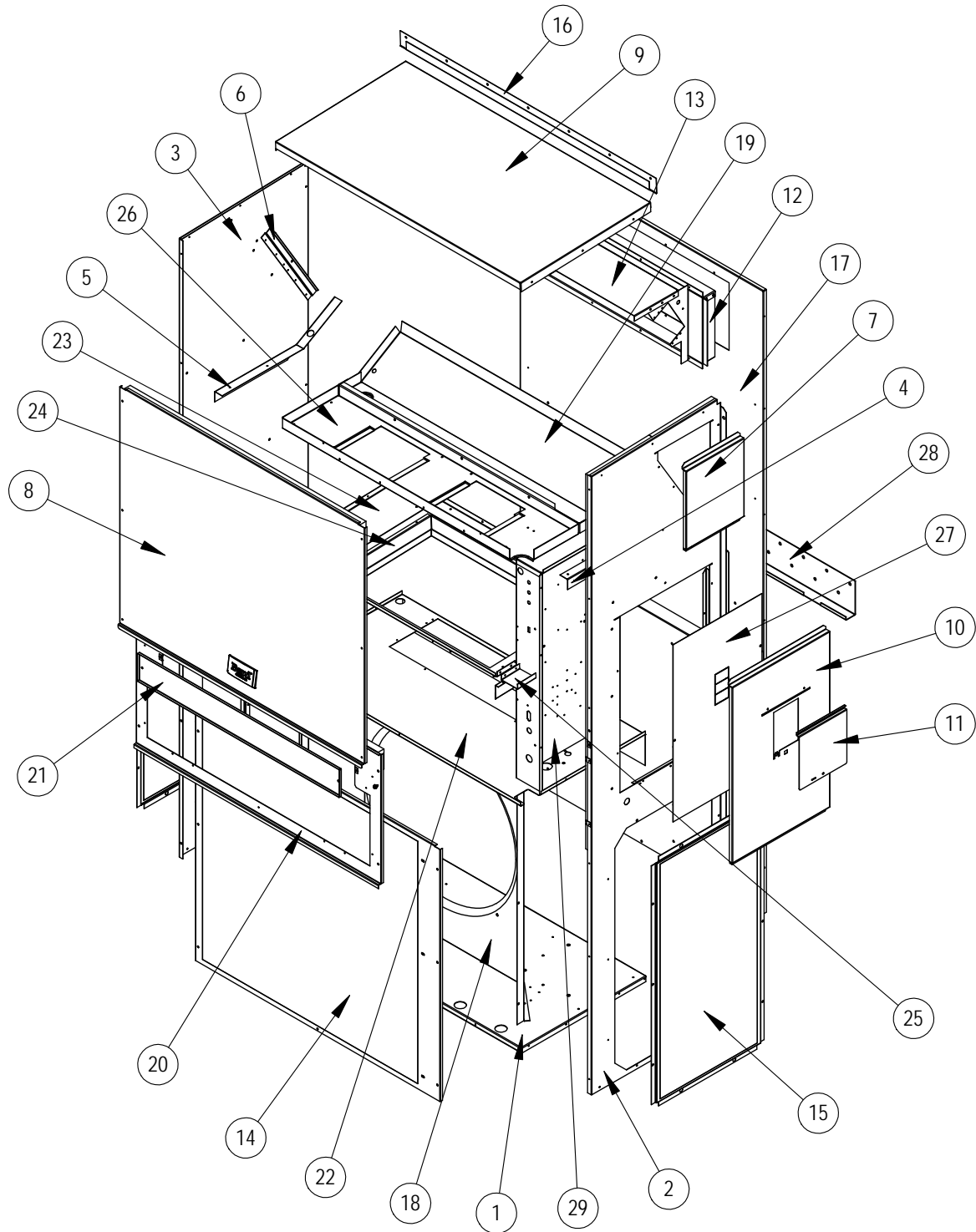

SEXP-713

## CABINET COMPONENTS – Right Hand

Dwg. No.	Part Number	Description	D28A2P-A, -B	D36A2P-A, -B	D42A2P-A, -B	D48A2P-A, -B	D60A2P-A, -B
1	S127-481	Base	X	X	X	X	X
2	S501-840-* ①	Right Side	X	X	X		
2	S501-841-* ①	Right Side				X	X
3	S501-686-* ①	Left Side	X	X	X		
3	S501-733-* ①	Left Side				X	X
4	105X878	Support Angle	X	X	X	X	X
5	105X877	Support Angle	X	X	X	X	X
6	147-046	Evap. Angle	X	X	X	X	X
7	543-172-* ①	Heater Access Cover	X	X	X	X	X
8	S515-230-* ①	Upper Front	X	X	X		
8	S515-246-* ①	Upper Front				X	X
9	507-307-* ①	Top	X	X	X	X	X
10	S533-256-* ①	Control Panel Cover	X	X	X	X	X
11	S153-218-* ①	Disconnect Access Door	X	X	X	X	X
12	S111X034	Outlet Airframe Assembly	X	X	X	X	X
13	135-129	Heat Shield	X	X	X	X	X
14	118-048-* ①	Condenser Grille	X	X	X		
14	118-085-* ①	Condenser Grille				X	X
15	118-057-* ①	Side Grille	2	2	2		
15	118-086-* ①	Side Grille				2	2
16	113-150-* ①	Rain Flashing	X	X	X	X	X
17	508-098	Back	X	X	X		
17	509-251	Back				X	X
18	125-069	Fan Shroud	X	X	X		
18	125-070	Fan Shroud				X	X
19	523-144	Drain Pan Assembly	X	X	X	X	X
20	553-600-* ①	Hood Mounting Door	X	X	X	X	X
21	553-564	Filter Door	X	X	X	X	X
22	521X258	Condenser Partition	X	X	X	X	X
23	131X164	Filter Tray	X	X	X	X	X
24	131-165	Filter Tray Angle	X	X	X	X	X
25	137-209	Fill Plate	X	X	X	X	X
26	121X501	Blower Partition	X	X	X	X	X
27	S132-255	Inner Control Panel Cover	X	X	X	X	X
28	113-140	Bottom Support Bracket	X	X	X	X	X
29	Control Panel Assembly	See Control Panel Assembly Drawing & Parts List	X	X	X	X	X

① Exterior cabinet parts are manufactured with various paint color options. To ensure the proper paint color is received, reference the following codes:

Beige	-X	Buckeye Gray	-4
White	-1		

# CABINET COMPONENTS - Left Hand

---

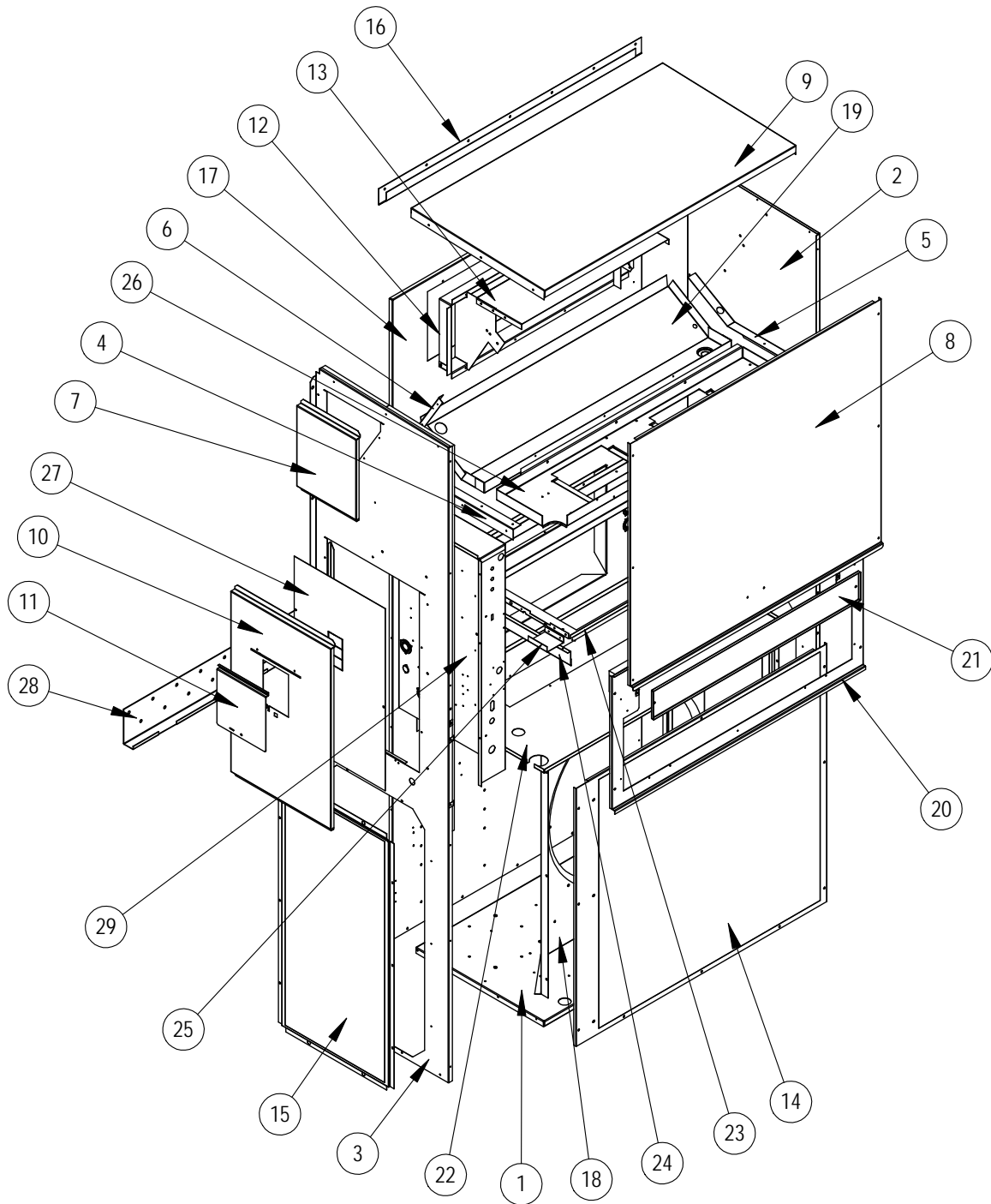

SEXP-714

## CABINET COMPONENTS - Left Hand

Dwg. No.	Part Number	Description	D28L2P-A, -B	D36L2P-A, -B	D42L2P-A, -B	D48L2P-A, -B	D60L2P-A, -B
1	S127-482	Base	X	X	X	X	X
2	S501-687-* ①	Right Side	X	X	X		
2	S501-826-* ①	Right Side				X	X
3	S501-842-* ①	Left Side	X	X	X		
3	S501-843-* ①	Left Side				X	X
4	105Y878	Support Angle	X	X	X	X	X
5	105Y877	Support Angle	X	X	X	X	X
6	147-046	Evap. Angle	X	X	X	X	X
7	543-172-* ①	Heater Access Cover	X	X	X	X	X
8	S515-230-* ①	Upper Front	X	X	X		
8	S515-246-* ①	Upper Front				X	X
9	507-307-* ①	Top	X	X	X	X	X
10	S533-257-* ①	Control Panel Cover	X	X	X	X	X
11	S153-218-* ①	Disconnect Access Door	X	X	X	X	X
12	S111Y034	Outlet Airframe Assembly	X	X	X	X	X
13	135-129	Heat Shield	X	X	X	X	X
14	118-049-* ①	Condenser Grille	X	X	X		
14	118-094-* ①	Condenser Grille				X	X
15	118-057-* ①	Side Grille	2	2	2		
15	118-086-* ①	Side Grille				2	2
16	113-150-* ①	Rain Flashing	X	X	X	X	X
17	508-098	Back	X	X	X		
17	509-251	Back				X	X
18	125-069	Fan Shroud	X	X	X		
18	125-070	Fan Shroud				X	X
19	523-145	Drain Pan Assembly	X	X	X	X	X
20	553-600-* ①	Hood Mounting Door	X	X	X	X	X
21	553-564	Filter Door	X	X	X	X	X
22	521Y258	Condenser Partition	X	X	X	X	X
23	131Y164	Filter Tray	X	X	X	X	X
24	131-165	Filter Tray Angle	X	X	X	X	X
25	137-209	Fill Plate	X	X	X	X	X
26	121Y501	Blower Partition	X	X	X	X	X
27	S132-255	Inner Control Panel Cover	X	X	X	X	X
28	113-140	Bottom Support Bracket	X	X	X	X	X
29	Control Panel Assembly	See Control Panel Assembly Drawing & Parts List	X	X	X	X	X

① Exterior cabinet parts are manufactured with various paint color options. To ensure the proper paint color is received, reference the following codes:

Beige	-X	Buckeye Gray	-4
White	-1		

# FUNCTIONAL COMPONENTS

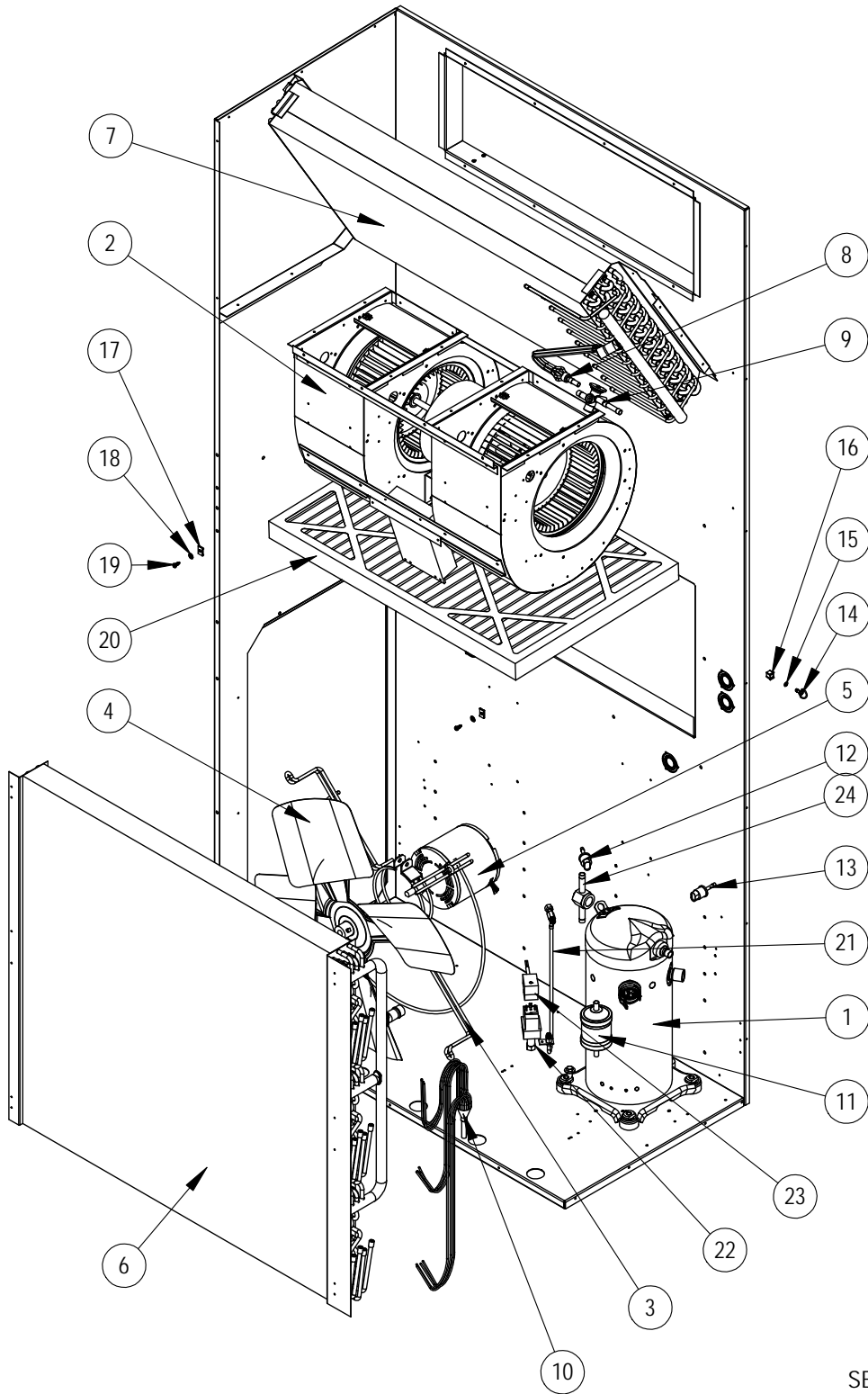

SEXP-715

This drawing is referenced in tables on pages 7 and 8

## FUNCTIONAL COMPONENTS – Single Phase Units

Dwg. No.	Part Number	Description	D28A2P-A	D28L2P-A	D36A2P-A	D36L2P-A	D42A2P-A	D42L2P-A	D48A2P-A	D48L2P-A	D60A2P-A	D60L2P-A
1	8000-314	Compressor	X	X								
1	8000-278	Compressor			X	X						
1	8000-362	Compressor					X	X				
1	8000-332	Compressor							X	X		
1	8000-324	Compressor									X	X
2	S900-357	Blower Assembly	X	X	X	X	X	X	X	X	X	X
3	8200-004	Fan Motor Mount	X	X	X	X	X	X	X	X	X	X
4	5151-060	Fan Blade	X	X	X	X	X	X	X	X	X	X
5	8105-068	Condenser Motor	X	X	X	X	X	X	X	X	X	X
6	5051-107BX	Condenser Coil	X	X	X	X						
6	5051-167BX	Condenser Coil					X	X				
6	5051-193BX	Condenser Coil							X	X	X	X
7	5060-164BX	Evaporator Coil	X	X	X	X						
7	917-0184BX	Evaporator Coil					X	X				
7	917-0190BX	Evaporator Coil							X	X	X	X
8	800-0342	Cooling Distributor	X	X								
8	800-0409	Cooling Distributor			X	X						
8	800-0383	Cooling Distributor					X	X				
8	800-0415	Cooling Distributor							X	X		
8	800-0416	Cooling Distributor									X	X
9	5651-239	Expansion Valve	X	X								
10	800-0440	Heating Distributor			X							
10	800-0441	Heating Distributor				X						
10	800-0444	Heating Distributor					X					
10	800-0445	Heating Distributor						X				
10	800-0439	Heating Distributor							X		X	
10	800-0438	Heating Distributor								X		X
11	5201-022	Filter Drier	X	X	X	X	X	X	X	X	X	X
12	1804-0462	High Pressure Switch (Flare)	X	X	X	X	X	X	X	X	X	X
13	1804-0386	Low Pressure Switch (Flare)	X	X	X	X	X	X	X	X	X	X
14	1171-022	1/4" Turn Fastener	X	X	X	X	X	X	X	X	X	X
15	1171-024	1/4" Retainer Clip	X	X	X	X	X	X	X	X	X	X
16	1171-023	1/4" Receptacle	X	X	X	X	X	X	X	X	X	X
17	1171-028	No. 9 Clip on Receptacle	2	2	2	2	2	2	2	2	2	2
18	1171-027	No. 9 Retainer Clip	2	2	2	2	2	2	2	2	2	2
19	1171-057	No. 9 Captive Screw Fastener	2	2	2	2	2	2	2	2	2	2
20	7004-027	Air Filter 2" Pleated MERV 8 ①	X	X	X	X	X	X	X	X	X	X
20	7004-049	Air Filter 2" Pleated MERV 11 ①	X	X	X	X	X	X	X	X	X	X
21	1804-0541	Low Ambient Control Extension Tube			X		X		X		X	
21	1804-0544	Low Ambient Control Extension Tube				X		X		X		X
22	8612-027	230V Head Pressure Control			X	X	X	X	X	X	X	X
23	8611-115	Plug & Wire Assembly			X	X	X	X	X	X	X	X
24	5201-014	Sight Glass	X	X	X	X	X	X	X	X	X	X
NS	3000-1222	Compressor Power Plug	X	X	X	X	X	X	X	X	X	X
NS	8605-019	Crankcase Heater ①	X	X	X	X	X	X				
NS	8605-015	Crankcase Heater ①							X	X	X	X
NS	8301-056	Temperature/Humidity Sensor	X	X	X	X	X	X	X	X	X	X
NS	3020-005	Wire Assembly to Outdoor Sensor	X	X	X	X	X	X	X	X	X	X

NS – Not Shown

① – Optional

# FUNCTIONAL COMPONENTS – Three Phase Units

Dwg. No.	Part Number	Description	D28A2P-B	D28L2P-B	D36A2P-B	D36L2P-B	D42A2P-B	D42L2P-B	D48A2P-B	D48L2P-B	D60A2P-B	D60L2P-B
1	8000-315	Compressor	X	X								
1	8000-283	Compressor			X	X						
1	8000-363	Compressor					X	X				
1	8000-333	Compressor							X	X		
1	8000-325	Compressor									X	X
2	S900-357	Blower Assembly	X	X	X	X	X	X	X	X	X	X
3	8200-004	Fan Motor Mount	X	X	X	X	X	X	X	X	X	X
4	5151-060	Fan Blade	X	X	X	X	X	X	X	X	X	X
5	8105-068	Condenser Motor	X	X	X	X	X	X	X	X	X	X
6	5051-107BX	Condenser Coil	X	X	X	X						
6	5051-167BX	Condenser Coil					X	X				
6	5051-193BX	Condenser Coil							X	X	X	X
7	5060-164BX	Evaporator Coil	X	X	X	X						
7	917-0184BX	Evaporator Coil					X	X				
7	917-0190BX	Evaporator Coil							X	X	X	X
8	800-0342	Cooling Distributor	X	X								
8	800-0409	Cooling Distributor			X	X						
8	800-0383	Cooling Distributor					X	X				
8	800-0415	Cooling Distributor							X	X		
8	800-0416	Cooling Distributor									X	X
9	5651-239	Expansion Valve	X	X								
10	800-0440	Heating Distributor			X							
10	800-0441	Heating Distributor				X						
10	800-0444	Heating Distributor					X					
10	800-0445	Heating Distributor						X				
10	800-0439	Heating Distributor							X		X	
10	800-0438	Heating Distributor								X		X
11	5201-022	Filter Drier	X	X	X	X	X	X	X	X	X	X
12	1804-0462	High Pressure Switch (Flare)	X	X	X	X	X	X	X	X	X	X
13	1804-0386	Low Pressure Switch (Flare)	X	X	X	X	X	X	X	X	X	X
14	1171-022	1/4" Turn Fastener	X	X	X	X	X	X	X	X	X	X
15	1171-024	1/4" Retainer Clip	X	X	X	X	X	X	X	X	X	X
16	1171-023	1/4" Receptacle	X	X	X	X	X	X	X	X	X	X
17	1171-028	No. 9 Clip on Receptacle	2	2	2	2	2	2	2	2	2	2
18	1171-027	No. 9 Retainer Clip	2	2	2	2	2	2	2	2	2	2
19	1171-057	No. 9 Captive Screw Fastener	2	2	2	2	2	2	2	2	2	2
20	7004-027	Air Filter 2" Pleated MERV 8 ①	X	X	X	X	X	X	X	X	X	X
20	7004-049	Air Filter 2" Pleated MERV 11 ①	X	X	X	X	X	X	X	X	X	X
21	1804-0541	Low Ambient Control Extension Tube			X		X		X		X	
21	1804-0544	Low Ambient Control Extension Tube				X		X		X		X
22	8612-027	230V Head Pressure Control			X	X	X	X	X	X	X	X
23	8611-115	Plug & Wire Assembly			X	X	X	X	X	X	X	X
24	5201-014	Sight Glass	X	X	X	X	X	X	X	X	X	X
NS	3000-1230	Compressor Power Plug	X	X	X	X	X	X	X	X	X	X
NS	8605-019	Crankcase Heater ①	X	X	X	X	X					
NS	8605-015	Crankcase Heater ①						X	X	X	X	
NS	8301-056	Temperature/Humidity Sensor	X	X	X	X	X	X	X	X	X	X
NS	3020-005	Wire Assembly to Outdoor Sensor	X	X	X	X	X	X	X	X	X	X

NS – Not Shown

① – Optional

**This table references the drawing on page 6**



*This page intentionally left blank*

# CONTROL PANEL - Right Hand

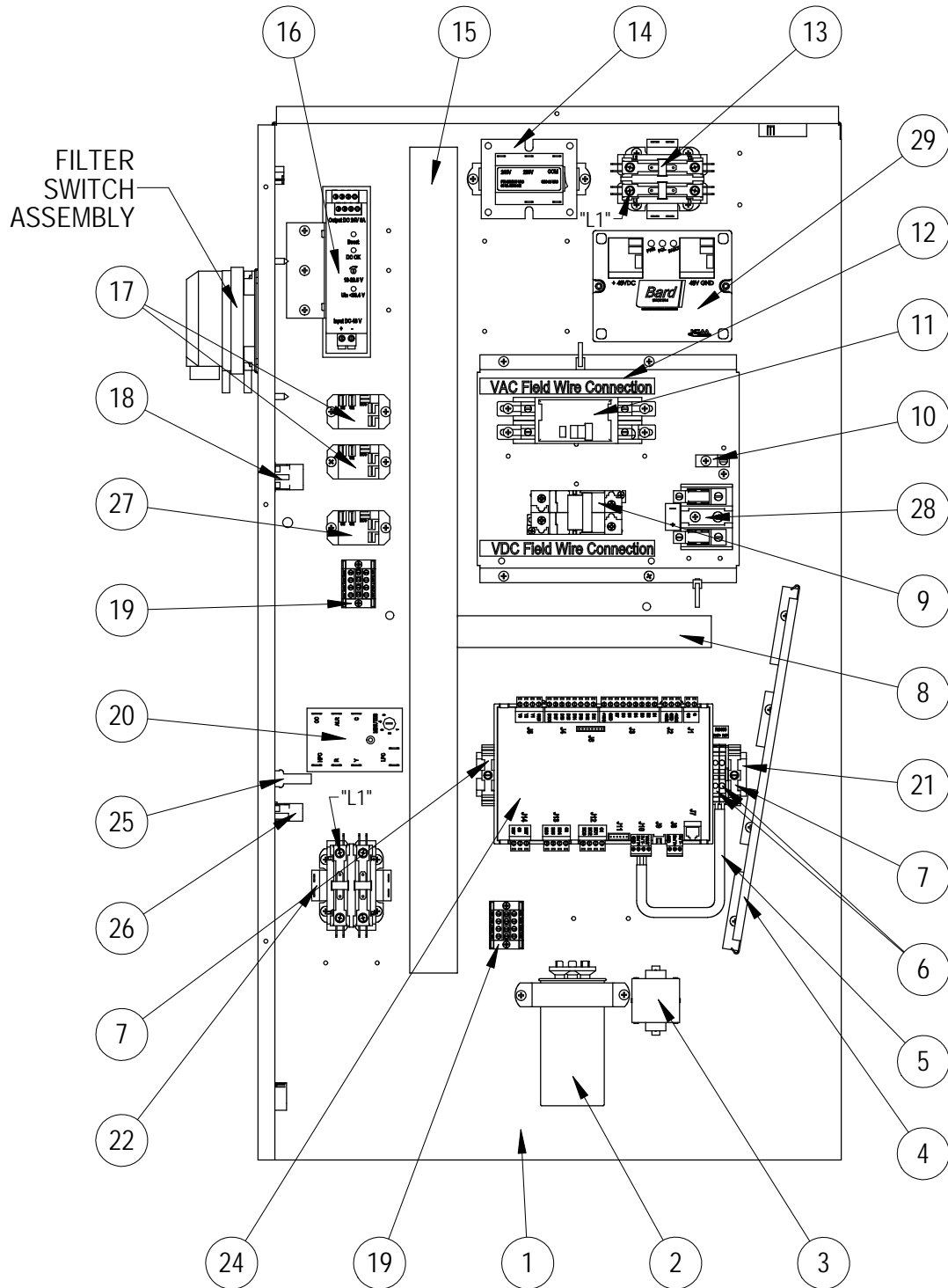

SEXP-750 A

This drawing is referenced in tables on pages 11 and 12

## CONTROL PANEL – Right Hand, Single Phase Units

Dwg. No.	Part Number	Description	D28AP2-A05	D36AP2-A05	D42A2P-A05	D48A2P-A05	D60A2P-A05
1	517X357	Control Panel	X	X	X	X	X
2	8552-080	Capacitor 40/10 MFD 370V	X				
2	8552-079	Capacitor 45/10 MFD 370V		X	X		
2	8552-089	Capacitor 70/10 MFD 370V				X	
2	8552-058	Capacitor 80/10 MFD 440V					X
3	8551-004	Motor Starting Device	X	X	X	X	X
4	135-122	Wire Shield	X	X	X	X	X
5	3020-004	12" 2 Conductor Shielded Cable	X	X	X	X	X
6	8611-150	Terminal Block for DIN Rail RS485	X	X	X	X	X
7	8611-144	End Clamp for DIN Rail	X	X	X	X	X
8	8611-140-0800	1-1/2" x 1" Cable Duct x 8"	X	X	X	X	X
9	8615-079	Circuit Breaker 20A 125 VDC	X	X	X	X	X
10	8611-006	Ground Terminal	X	X	X	X	X
11	8615-055	Circuit Breaker 40A 2-Pole	X	X	X	X	
11	8615-041	Circuit Breaker 60A 2-Pole					X
12	8615-057	Circuit Breaker Mounting Foot	X	X	X	X	X
13	8401-006	Contactors 2-Pole 20 Amp	1	1	1	1	1
14	8407-048	Transformer 208/240-24-75VA	X	X	X	X	X
15	8611-139-2600	1-1/2" x 1-1/2" Cable Duct 26"	X	X	X	X	X
16	8301-050	48VDC to 24VDC Converter 5 Amps	X	X	X	X	X
17	8201-130	Compressor and Power Loss SPDT Relays	2	2	2	2	2
18	3000-1595	Wire Assembly	X	X	X	X	X
19	8607-037	Terminal Block 4 Position	2	2	2	2	2
20	8201-088	Compressor Control Module	X	X	X	X	X
21	8611-145	35mm DIN Rail 8-1/2"	X	X	X	X	X
22	8401-034	Contactors 2-Pole 40 Amp	X	X	X	X	X
24	8301-051-003	Micro PC - Small	X	X	X	X	X
25	3000-1470	Vent Motor Plug	X	X	X	X	X
26	3000-1472	Blade Switch and Return Air Sensor Wire Assembly	X	X	X	X	X
27	8201-151	Blower Motor Start Relay SPDT 24VDC Coil	X	X	X	X	X
28	8607-013	Terminal Block	X	X	X	X	X
29	8201-156	DC Polarity-Voltage Monitor	X	X	X	X	X
NS	910-1946	Filter Switch Assembly	X	X	X	X	X
NS	4206-106	Unit Wiring Diagram	X	X	X	X	X

NS – Not Shown

# CONTROL PANEL – Right Hand, Three Phase Units

Dwg. No.	Part Number	Description	D28AP2-B06	D36AP2-B06	D42A2P-B06	D48A2P-B06	D60A2P-B06
1	517X357	Control Panel	X	X	X	X	X
2	8552-005	Capacitor 40/10 MFD 370V	X	X	X	X	X
3	8551-004	Motor Starting Device	X	X	X	X	X
4	135-122	Wire Shield	X	X	X	X	X
5	3020-004	12" 2 Conductor Shielded Cable	X	X	X	X	X
6	8611-150	Terminal Block for DIN Rail RS485	X	X	X	X	X
7	8611-144	End Clamp for DIN Rail	X	X	X	X	X
8	8611-140-0800	1-1/2" x 1" Cable Duct x 8"	X	X	X	X	X
9	8615-079	Circuit Breaker 20A 125 VDC	X	X	X	X	X
10	8611-006	Ground Terminal	X	X	X	X	X
11	8615-054	Circuit Breaker 20A 3-Pole	X				
11	8615-044	Circuit Breaker 45A 3-Pole		X	X		
11	8615-045	Circuit Breaker 50A 3-Pole				X	
11	8615-046	Circuit Breaker 60A 3-Pole					X
12	8615-057	Circuit Breaker Mounting Foot	X	X	X	X	X
13	8401-002	Contactors 3-Pole 20 Amp	1	1	1	1	1
14	8407-048	Transformer 208/240-24-75VA	X	X	X	X	X
15	8611-139-2600	1-1/2" x 1-1/2" Cable Duct 26"	X	X	X	X	X
16	8301-050	48VDC to 24VDC Converter 5 Amps	X	X	X	X	X
17	8201-130	Compressor and Power Loss SPDT Relays	2	2	2	2	2
18	3000-1595	Wire Assembly	X	X	X	X	X
19	8607-037	Terminal Block 4 Position	2	2	2	2	2
20	8201-088	Compressor Control Module	X	X	X	X	X
21	8611-145	35mm DIN Rail 8-1/2"	X	X	X	X	X
22	8401-035	Contactors 3-Pole 40 Amp	X	X	X	X	X
24	8301-051-003	Micro PC - Small	X	X	X	X	X
25	3000-1470	Vent Motor Plug	X	X	X	X	X
26	3000-1472	Blade Switch and Return Air Sensor Wire Assembly	X	X	X	X	X
27	8201-151	Blower Motor Start Relay SPDT 24VDC Coil	X	X	X	X	X
28	8607-013	Terminal Block	X	X	X	X	X
29	8201-156	DC Polarity-Voltage Monitor	X	X	X	X	X
NS	910-1946	Filter Switch Assembly	X	X	X	X	X
NS	4206-106	Unit Wiring Diagram	X	X	X	X	X
NS	8201-126	Phase Monitor	X	X	X	X	X

NS – Not Shown

This table references the drawing on page 10

*This page intentionally left blank*

# CONTROL PANEL - Left Hand

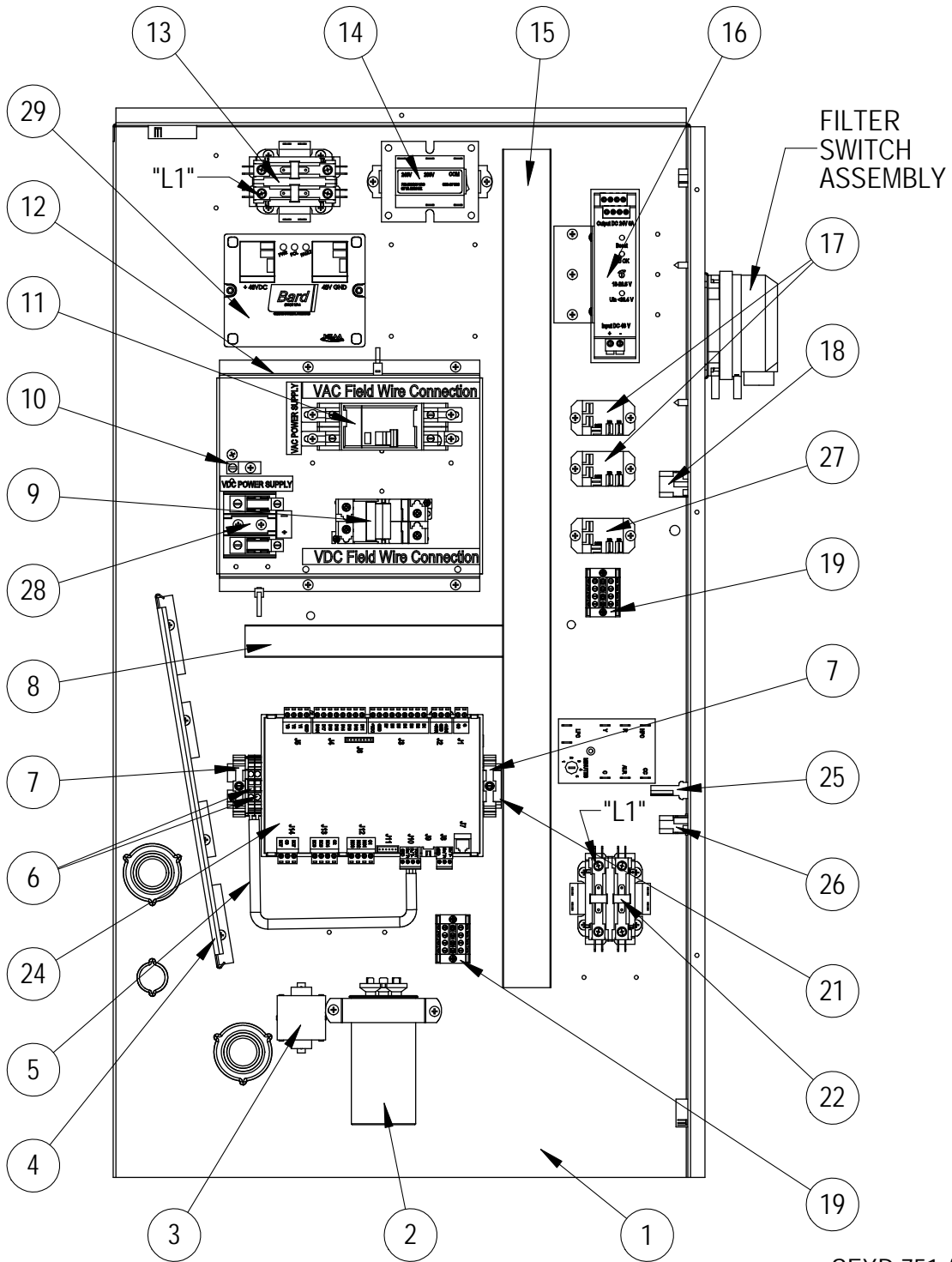

SEXP-751 A

This drawing is referenced in tables on pages 15 and 16

## CONTROL PANEL – Left Hand, Single Phase Units

Dwg. No.	Part Number	Description	D28L2P-A05	D36L2P-A05	D42L2P-A05	D48L2P-A05	D60L2P-A05
1	517Y357	Control Panel	X	X	X	X	X
2	8552-080	Capacitor 40/10 MFD 370V	X				
2	8552-079	Capacitor 45/10 MFD 370V		X	X		
2	8552-089	Capacitor 70/10 MFD 370V				X	
2	8552-058	Capacitor 80/10 MFD 440V					X
3	8551-004	Motor Starting Device	X	X	X	X	X
4	135-122	Wire Shield	X	X	X	X	X
5	3020-004	12" 2 Conductor Shielded Cable	X	X	X	X	X
6	8611-150	Terminal Block for DIN Rail RS485	X	X	X	X	X
7	8611-144	End Clamp for DIN Rail	X	X	X	X	X
8	8611-140-0800	1-1/2" x 1" Cable Duct x 8"	X	X	X	X	X
9	8615-079	Circuit Breaker 20A 125 VDC	X	X	X	X	X
10	8611-006	Ground Terminal	X	X	X	X	X
11	8615-055	Circuit Breaker 40A 2-Pole	X	X	X	X	
11	8615-041	Circuit Breaker 60A 2-Pole					X
12	8615-057	Circuit Breaker Mounting Foot	X	X	X	X	X
13	8401-006	Contactors 2-Pole 20 Amp	1	1	1	1	1
14	8407-048	Transformer 208/240-24-75VA	X	X	X	X	X
15	8611-139-2600	1-1/2" x 1-1/2" Cable Duct 26"	X	X	X	X	X
16	8301-050	48VDC to 24VDC Converter 5 Amps	X	X	X	X	X
17	8201-130	Compressor and Power Loss SPDT Relays	2	2	2	2	2
18	3000-1595	Wire Assembly	X	X	X	X	X
19	8607-037	Terminal Block 4 Position	2	2	2	2	2
20	8201-088	Compressor Control Module	X	X	X	X	X
21	8611-145	35mm DIN Rail 8-1/2"	X	X	X	X	X
22	8401-034	Contactors 2-Pole 40 Amp	X	X	X	X	X
24	8301-051-003	Micro PC - Small	X	X	X	X	X
25	3000-1470	Vent Motor Plug	X	X	X	X	X
26	3000-1472	Blade Switch and Return Air Sensor Wire Assembly	X	X	X	X	X
27	8201-151	Blower Motor Start Relay SPDT 24VDC Coil	X	X	X	X	X
28	8607-013	Terminal Block	X	X	X	X	X
29	8201-156	DC Polarity-Voltage Monitor	X	X	X	X	X
NS	910-1946	Filter Switch Assembly	X	X	X	X	X
NS	4206-106	Unit Wiring Diagram	X	X	X	X	X

NS – Not Shown

# CONTROL PANEL – Left Hand, Three Phase Units

Dwg. No.	Part Number	Description	D28LP2-B06	D36LP2-B06	D42LP2-B06	D48LP2-B06	D60LP2-B06
1	517Y357	Control Panel	X	X	X	X	X
2	8552-005	Capacitor 40/10 MFD 370V	X	X	X	X	X
3	8551-004	Motor Starting Device	X	X	X	X	X
4	135-122	Wire Shield	X	X	X	X	X
5	3020-004	12" 2 Conductor Shielded Cable	X	X	X	X	X
6	8611-150	Terminal Block for DIN Rail RS485	X	X	X	X	X
7	8611-144	End Clamp for DIN Rail	X	X	X	X	X
8	8611-140-0800	1-1/2" x 1" Cable Duct x 8"	X	X	X	X	X
9	8615-079	Circuit Breaker 20A 125 VDC	X	X	X	X	X
10	8611-006	Ground Terminal	X	X	X	X	X
11	8615-054	Circuit Breaker 20A 3-Pole	X				
11	8615-044	Circuit Breaker 45A 3-Pole		X	X		
11	8615-045	Circuit Breaker 50A 3-Pole				X	
11	8615-046	Circuit Breaker 60A 3-Pole					X
12	8615-057	Circuit Breaker Mounting Foot	X	X	X	X	X
13	8401-002	Contactactor 3-Pole 20 Amp	1	1	1	1	1
14	8407-048	Transformer 208/240-24-75VA	X	X	X	X	X
15	8611-139-2600	1-1/2" x 1-1/2" Cable Duct 26"	X	X	X	X	X
16	8301-050	48VDC to 24VDC Converter 5 Amps	X	X	X	X	X
17	8201-130	Compressor and Power Loss SPDT Relays	2	2	2	2	2
18	3000-1595	Wire Assembly	X	X	X	X	X
19	8607-037	Terminal Block 4 Position	2	2	2	2	2
20	8201-148	Compressor Control Module	X	X	X	X	X
21	8611-145	35mm DIN Rail 8-1/2"	X	X	X	X	X
22	8401-035	Contactactor 3-Pole 40 Amp	X	X	X	X	X
24	8301-051-003	Micro PC - Small	X	X	X	X	X
25	3000-1470	Vent Motor Plug	X	X	X	X	X
26	3000-1472	Blade Switch and Return Air Sensor Wire Assembly	X	X	X	X	X
27	8201-151	Blower Motor Start Relay SPDT 24VDC Coil	X	X	X	X	X
28	8607-013	Terminal Block	X	X	X	X	X
29	8201-156	DC Polarity-Voltage Monitor	X	X	X	X	X
NS	910-1946	Filter Switch Assembly	X	X	X	X	X
NS	4206-106	Unit Wiring Diagram	X	X	X	X	X
NS	8201-126	Phase Monitor	X	X	X	X	X

NS – Not Shown

**This table references the drawing on page 14**



*This page intentionally left blank*

# BLOWER ASSEMBLY

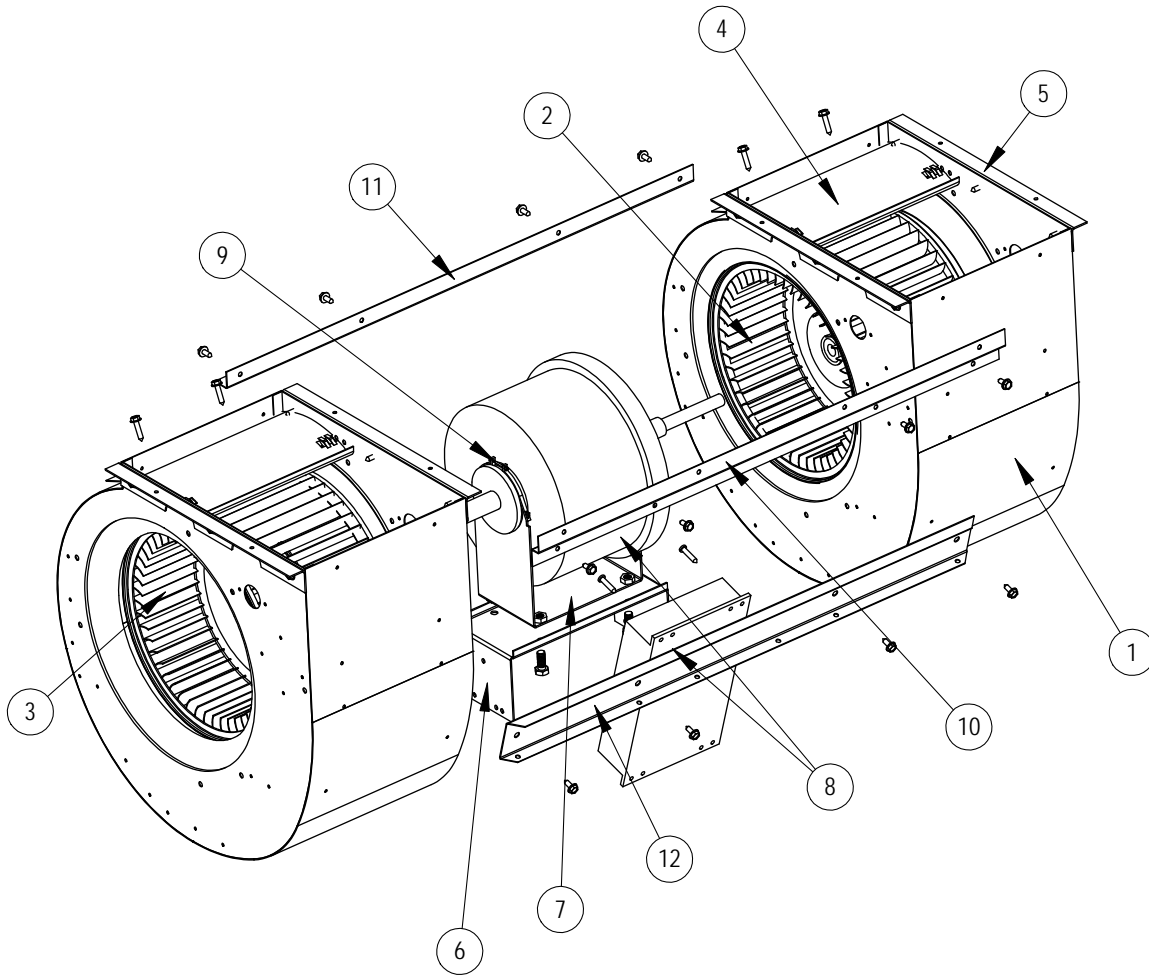

SEXP-718 A

Dwg. No.	Part Number	Description	S900-357
1	151-117	Blower Housing	2
2	5152-072	Blower Wheel	X
3	5152-096	Blower Wheel	X
4	144-167	Diffuser	2
5	105-880	Blower Angle	4
6	129-024	Cradle Support	1
7	129-022	Cradle Motor Mount	X
8	8107-021	3/4 HP Motor	X
8	8107-025	Motor Controller	X
9	8200-018	Motor Mount Latch	2
10	103-514	Hold In Offset	X
11	105-1332	Rear Blower Angle	X
12	113-518	Motor Controller Mount	X

# DC FREE COOLING

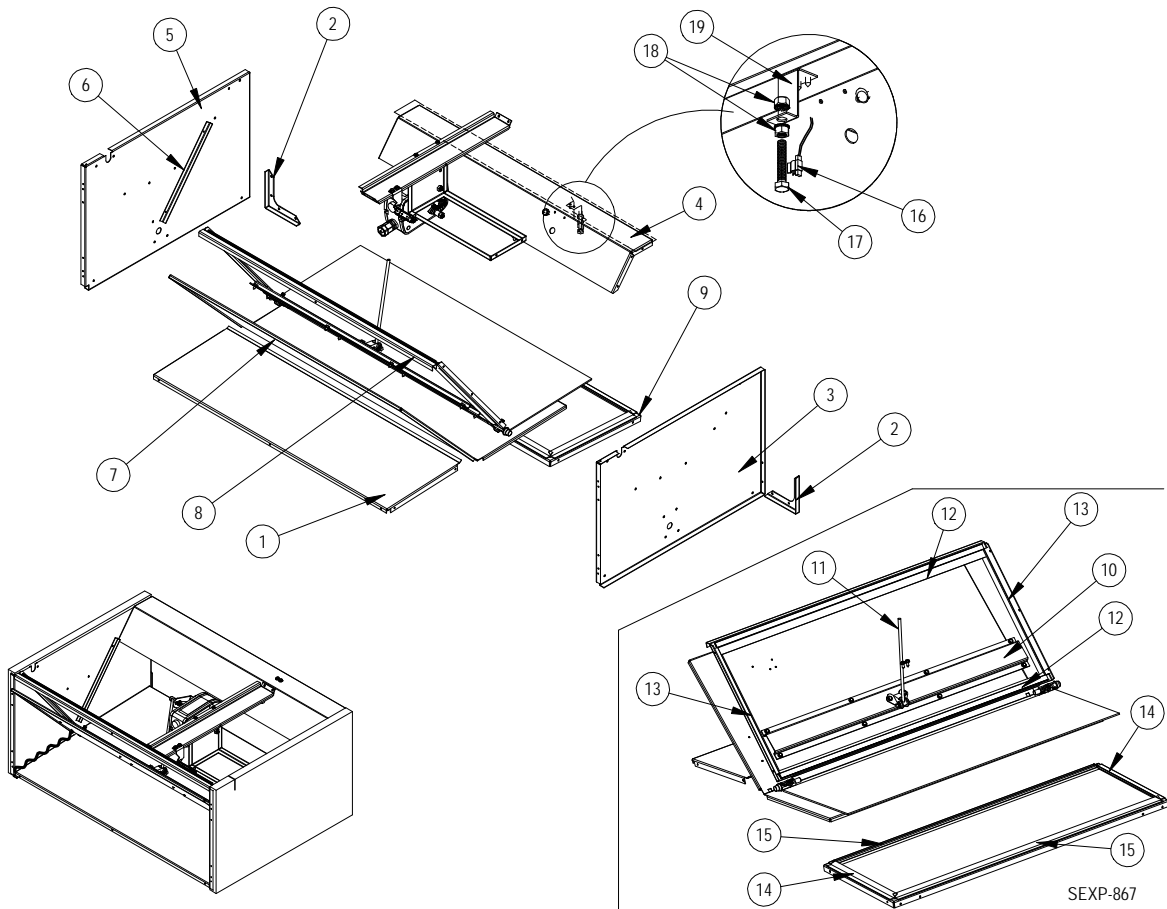

Dwg. No.	Part Number	Description
1	137-734	Lower Front Partition
2	113-526	Corner Bracket
3	S101X981	Right Side
4	S137-871	Upper Rear Partition
5	S101Y981	Left Side
6	S105-1341	Blade Seal Angle
7	S139-323	Blade
8	S137-870	Upper Front Partition
9	S137-736	Lower Rear Partition
10	141-426	Blade Support
11	8602-077	1/4 x 9" Rod
12	1921-067-2909	29-9/16" Damper Blade Seal
13	1921-067-1300	13" Damper Blade Seal
14	1921-067-1011	10-11/16" Damper Blade Seal
15	1921-067-2906	29-3/8" Damper Blade Seal
16	8408-044	Return Air Sensor 10K Ohm Curve J w/ 5/16" Clip
17	1012-052	Hex Head Bolt 5/16 - 18x1-3/4" 0.0005 Zinc w/ Yellow Chromate
18	1012-210	5/16" Nut 0.0005 Zinc w/ Yellow Chromate
19	113-541	Sensor Bracket

# DC FREE COOLING AIR HOOD

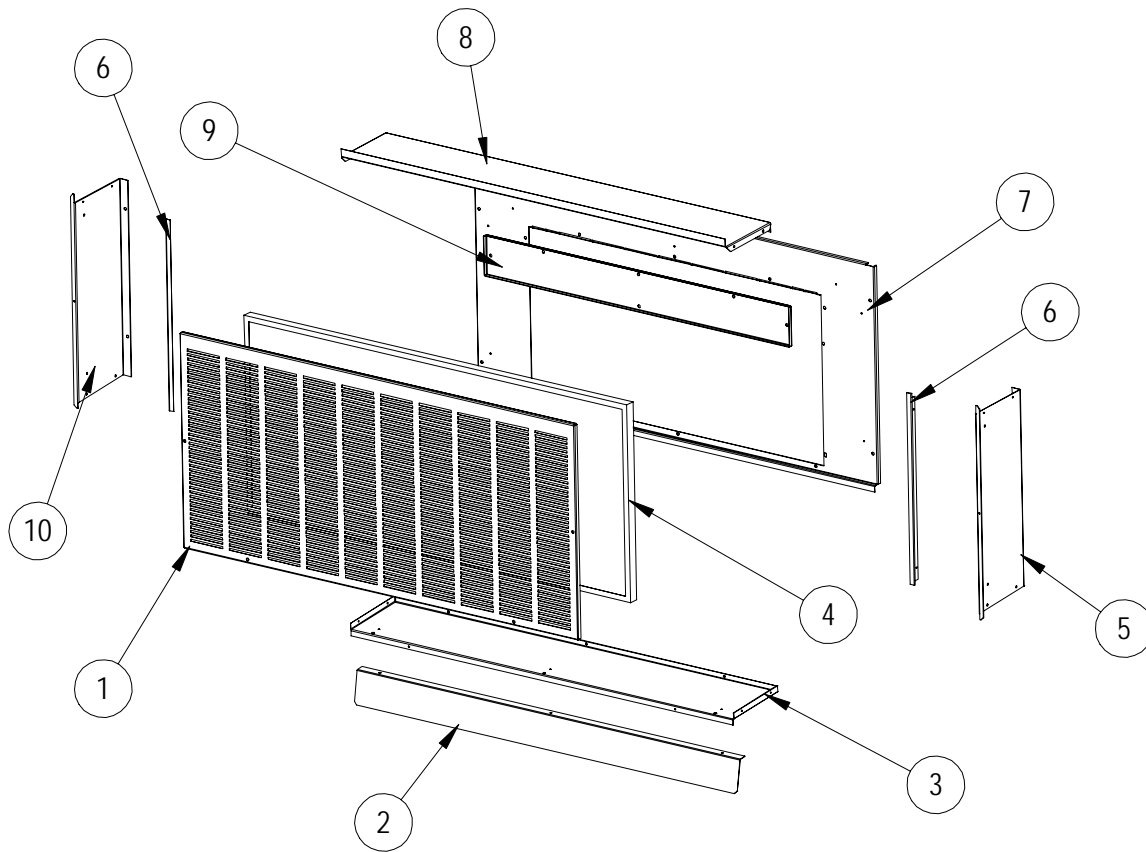

SEXP-752A

1	115-283-* ①	Hooded Front Door
2	113-484-* ①	Bottom Divider Bracket
3	S127-489-* ①	Hood Bottom
4	7003-062	Mist Filter 40-1/4" x 17-7/8" x 7/8"
5	S101-870-* ①	Right Side
6	105-1342	Side Filter Angle
7	553-600-* ①	Hood Mounting Door
8	S107-344-* ①	Hood Top
9	553-641	Filter Door
10	S101-860-* ①	Left Side
	S920-0261	Complete Hood Assembly - Beige
	S920-0262	Complete Hood Assembly - White
	S920-0263	Complete Hood Assembly - Buckeye Gray

① Exterior cabinet parts are manufactured with various paint color options.  
To ensure the proper paint color is received, reference the following codes:

Beige	-X	Buckeye Gray	-4
White	-1		

# DC FREE COOLING DAMPER MOTOR

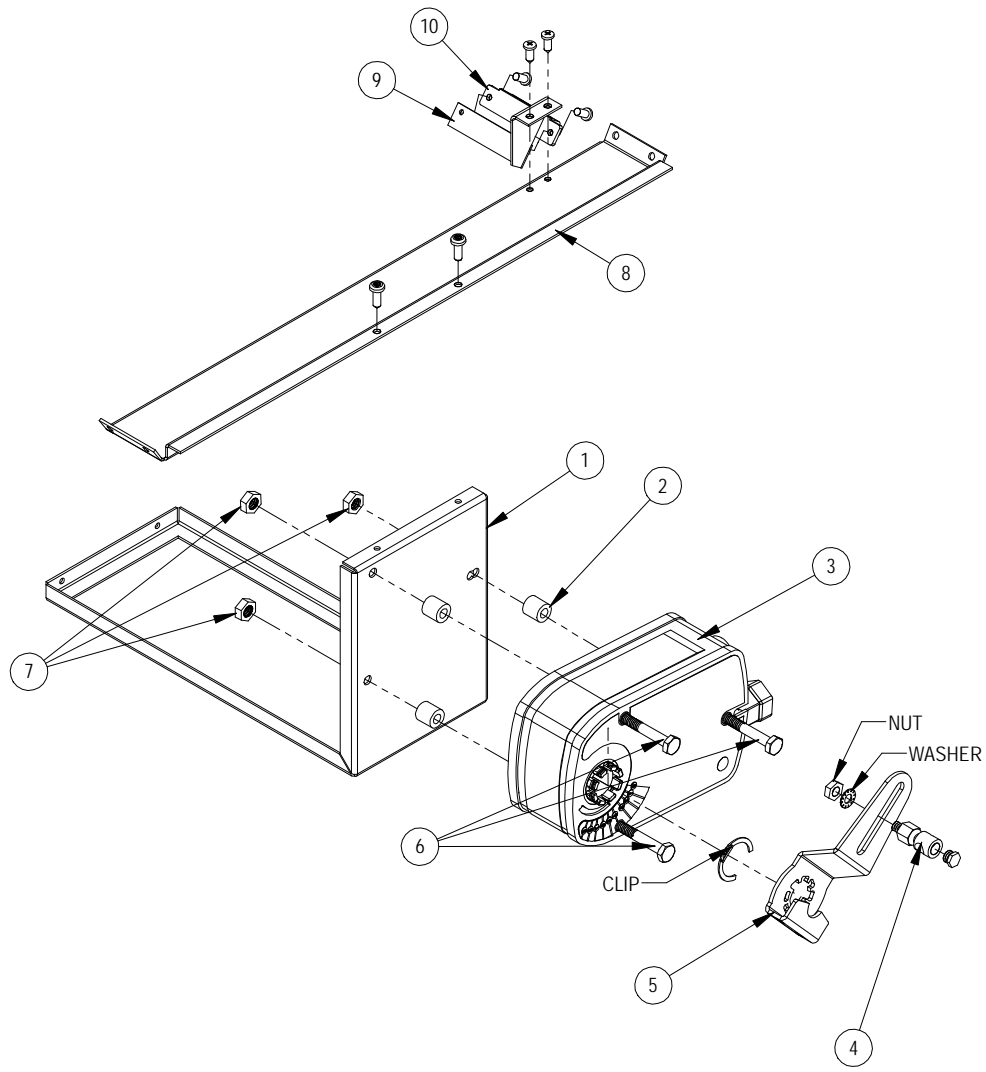

SEXP-868

1	141-467	Actuator Support Plate
2	5451-029	Nylon Sleeve 0.257" ID x 0.5" Long
3	8602-075	Direct Coupled Actuator
4	8602-008	Ball Joint
5	8602-078	Belimo Actuator Crank Arm 1/2"
6	1012-174	1/4" - 20x3 - 1/4 Hex Cap Screws
7	1012-201	1/4-20 Steel Keps Hex Nut Zinc
8	141-468	Actuator Support Bar
9	113-655	Blade Switch Bracket
10	8406-150	Lever Switch SPDT Sealed Pilot Duty
11	1012-178	4-40 x 5/8" Phillips Pan Head Machine Screw, Zinc Plated
12	1012-231	4-40 Steel Keps Hex Nut Zinc

# BARD-LINK™ PLC LEAD/LAG CONTROLLER

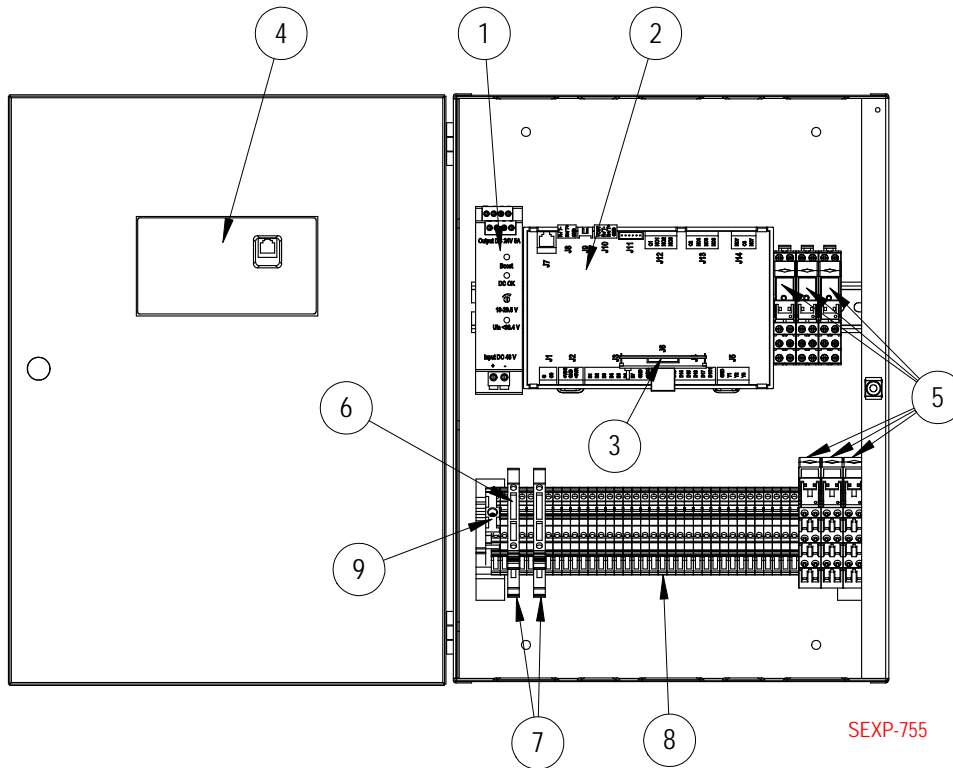

Dwg. No.	Part Number	Description	LC1000	LC1500	LC2000
1	8301-050	48VDC to 24VDC Converter 5 Amps	X	X	
2	8301-051-001	Micro PC – Small, programmed for LC1000/LC1500	X	X	
2	8301-051-005	Micro PC – Small, programmed for LC2000			X
3	8301-052	Web Card (Ethernet 1BaseT card for SNMP, FTP, HTTP, DHCP, DNS, BACnet over IP and BACnet Ethernet)	X	X	X
4	8301-053	Panel mounting display flush, pGDEvolution 132x64, black buttons with cable	X	X	X
5	8201-154	24VDC Isolation Relay, DPDT	6	6	6
6	8614-055	2.5 Amp Fuse	2	2	2
7	8607-039	Fused Terminal Block	2	2	2
8	8607-038	Terminal Block	32	32	32
9	8611-144	End Clamp (for din rail)	2	2	2
NS	8607-057	Double Level Terminal Block	3	3	3
NS	8907-052	Ground Terminal Block	X	X	X
NS	8301-055	EMI Ferrite Filter	2	2	2
NS	8301-058	Remote Temperature Sensor*	X	X	X
NS	8403-079	Remote Temperature/Humidity Sensor	X	X	X
NS	8611-181	Umbilical Cord for Punch-Down Alarm Block		X	
NS	8607-040	66 Punch-Down Alarm Block		X	
NS	8301-060	Smoke Detector		X	
NS	8301-061	Hydrogen Detector*		X	
NS	8301-059	TEC-EYE™ (Service Tool), 5 ft. telephone cable	X	X	X

NS – Not Shown

\* Optional