REPLACEMENT PARTS MANUAL

WALL MOUNTED PACKAGE AIR CONDITIONER

Models:

J18AA-A J18LA-A J24AA-A J24LA-A
J24AA-B J24LA-B
J24AA-C

Contents

<u>Description</u>	<u>Page</u>	<u>Description</u>	<u>Page</u>
Cabinet Components – Right Hand Models		Blower Assembly – Right & Left Hand Models	
♦ Exploded View	2	♦ Exploded View	14
♦ Usage List	3	♦ Usage List	14
Cabinet Components – Left Hand Models			
♦ Exploded View	4		
♦ Usage List	5		
Functional Components – Right Hand Models			
♦ Exploded View	6		
♦ Usage List	7		
Functional Components – Left Hand Models			
♦ Exploded View	8		
♦ Usage List	9		
Control Panel – Right Hand Models			
♦ Exploded View	10		
♦ Usage List	11		
Control Panel – Left Hand Models			
♦ Exploded View	12		
♦ Usage List	13		

General Notes

- Revised and/or additional pages may be issued from time to time.
- A complete and current manual consists of pages shown in the following contents section.

Important

- Contact the installing and/or local Bard distributor for all parts requirements. Make sure to have the complete model and serial number available from the unit rating plates.



Manual: 2110-1432A
Supersedes: 2110-1432
Date: 10-11-17

CABINET COMPONENTS - RIGHT

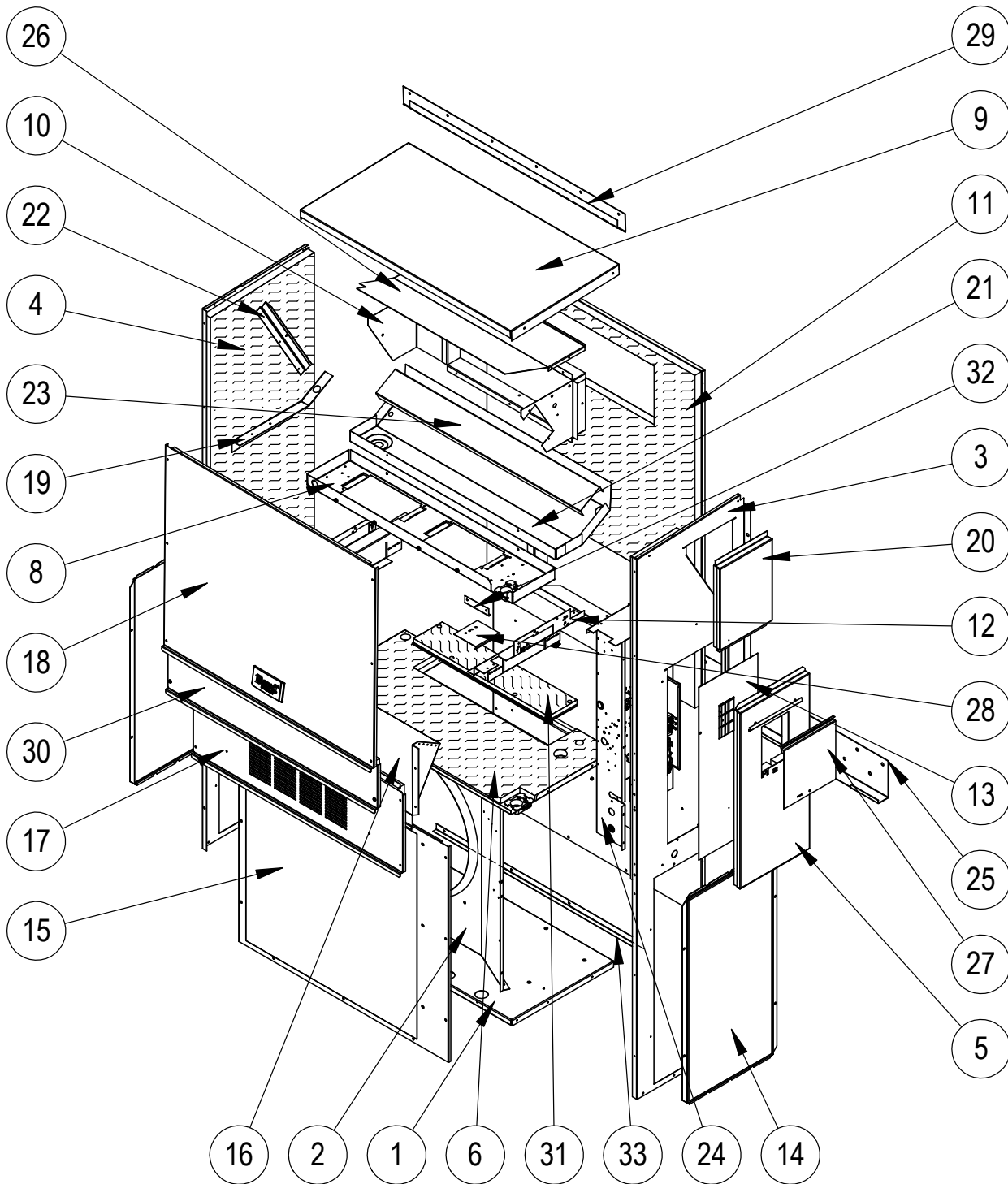

SEXP-804

CABINET COMPONENTS – RIGHT

Dwg No.	Part Number	Description	J18AA-A	J24AA-A, B	J24AA-C
1	127-467	Lower Base	X	X	X
2	125-080	Fan Shroud	X	X	X
3	S501-933-* ①	Right Side	X	X	X
4	S501-934-* ①	Left Side	X	X	X
5	S533-228-* ①	Control Panel Cover (Outer)	X	X	X
6	S521X528	Condenser Partition	X	X	X
8	121X480	Blower Partition	X	X	X
9	S507-311-* ①	Top	X	X	X
10	S111X032	Outlet Air Frame Assembly	X	X	X
11	S508-342	Back	X	X	X
12	113X480	Filter Bracket	2	2	2
13	S132-104	Control Panel Cover (Inner)	X	X	
13	S132-172	Control Panel Cover (Inner)			X
14	118-105-* ①	Side Grille	2	2	2
15	118-101-* ①	Condenser Grille	X	X	X
16	BFAD-2	Fresh Air Damper Assembly	X	X	X
17	S553-537-* ①	Vent Option Door	X	X	X
17	S553-539 ①	Vent Option Door with ERV	X	X	X
18	S514-276-* ①	Upper Front	X	X	X
19	105X850	Side Support	X	X	X
20	S543-175-* ①	Right Side Cover Plate (Outer)	X	X	X
21	S123-126	Drain Pan	X	X	X
22	147-044	Evaporator Support	X	X	X
23	137-694	Bottom Evaporator Fill	X	X	X
24	Control Panel Assembly	See Control Panel Assy. Drawing & Parts List Assy.	X	X	X
25	113-140	Bottom Mounting Bracket	X	X	X
26	135X127	Heat Shield	X	X	X
27	S153-218 ①	Disconnect Access Door	X	X	X
28	137-259	Fill Plate	X	X	X
29	113-141-* ①	Top Rain Flashing	X	X	X
30	S553-538-* ①	Filter Door	X	X	X
31	S536-176	Cond. Partition Block Off Plate	X	X	X
32	105-1302	Grommet Retainer	X	X	X
33	105-1392	Close Off Angle	X	X	X

① Exterior cabinet parts are manufactured with various paint color options. To ensure the proper paint color is received, include the complete model and serial number of the unit for which cabinet parts are being ordered.

CABINET COMPONENTS - LEFT

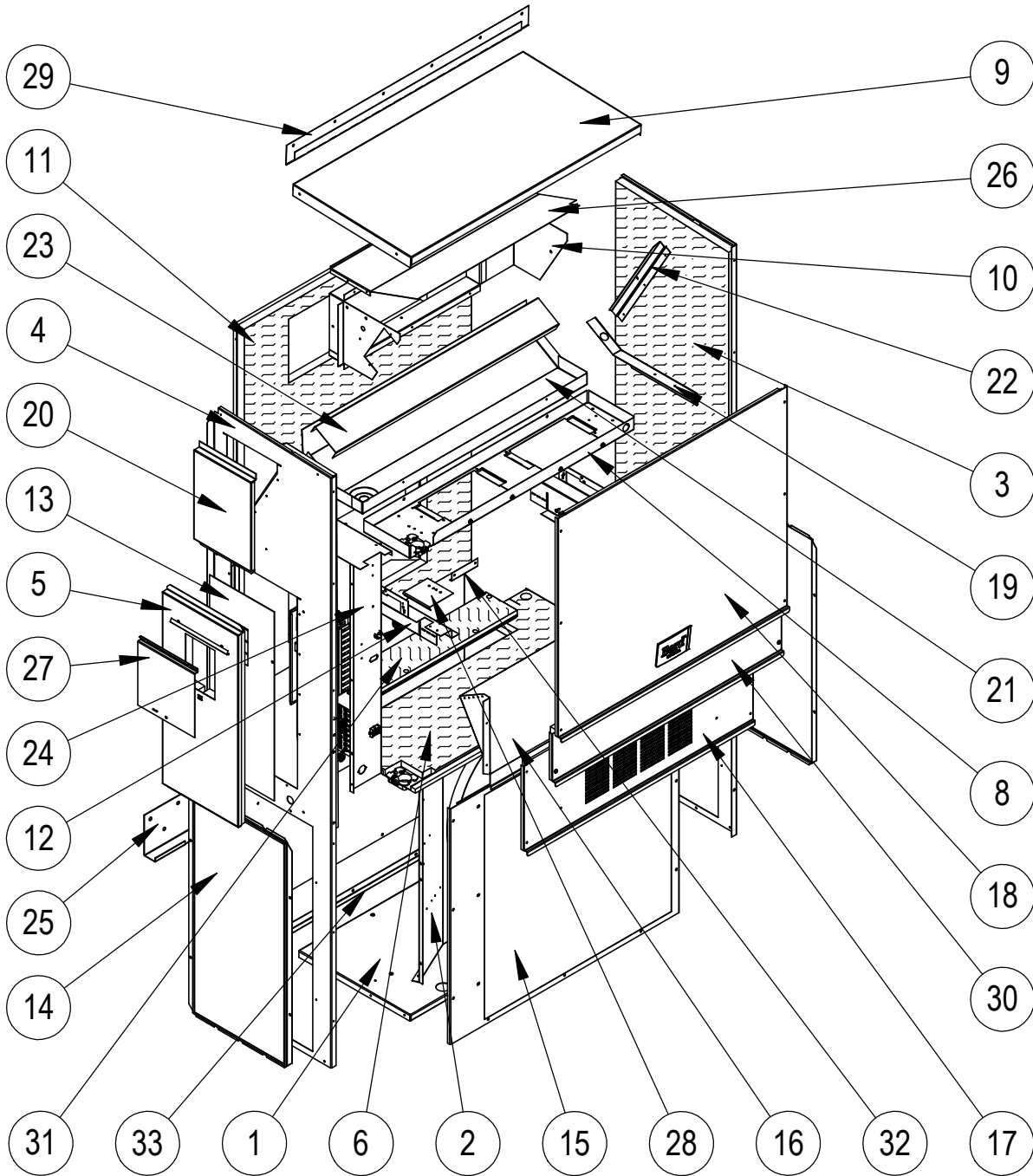

SEXP-807

CABINET COMPONENTS – LEFT

Dwg No.	Part Number	Description	J18LA-A	J24LA-A, -B
1	S127-468	Lower Base	X	X
2	125-080	Fan Shroud	X	X
3	S501-935-* ①	Right Side	X	X
4	S501-936-* ①	Left Side	X	X
5	S533-228-* ①	Control Panel Cover (Outer)	X	X
6	S521Y528	Condenser Partition	X	X
8	121Y480	Blower Partition	X	X
9	S507-311-* ①	Top	X	X
10	S111Y032	Outlet Air Frame Assembly	X	X
11	S508-342	Back	X	X
12	113Y480	Filter Bracket	2	2
13	S132-104	Control Panel Cover (Inner)	X	X
14	118-105-* ①	Side Grille	2	2
15	118-102-* ①	Condenser Grille	X	X
16	BFAD-2	Fresh Air Damper Assembly	X	X
17	S553-537-* ①	Vent Option Door	X	X
18	S514-276-* ①	Upper Front	X	X
19	105Y850	Side Support	X	X
20	S543-175-* ①	Right Side Cover Plate (Outer)	X	X
21	S123-131	Drain Pan	X	X
22	147-044	Evaporator Support	X	X
23	137-694	Bottom Evaporator Fill	X	X
24	Control Panel Assembly	See Control Panel Assy. Drawing & Parts List Assy.	X	X
25	113-140	Bottom Mounting Bracket	X	X
26	135Y127	Heat Shield	X	X
27	S153-218 ①	Disconnect Access Door	X	X
28	137-259	Fill Plate	X	X
29	113-141-* ①	Top Rain Flashing	X	X
30	S553-538-* ①	Filter Door	X	X
31	S536-176	Cond. Partition Block Off Plate	X	X
32	105-1302	Grommet Retainer	X	X
33	105-1392	Close Off Angle	X	X

① Exterior cabinet parts are manufactured with various paint color options. To ensure the proper paint color is received, include the complete model and serial number of the unit for which cabinet parts are being ordered.

FUNCTIONAL COMPONENTS - RIGHT

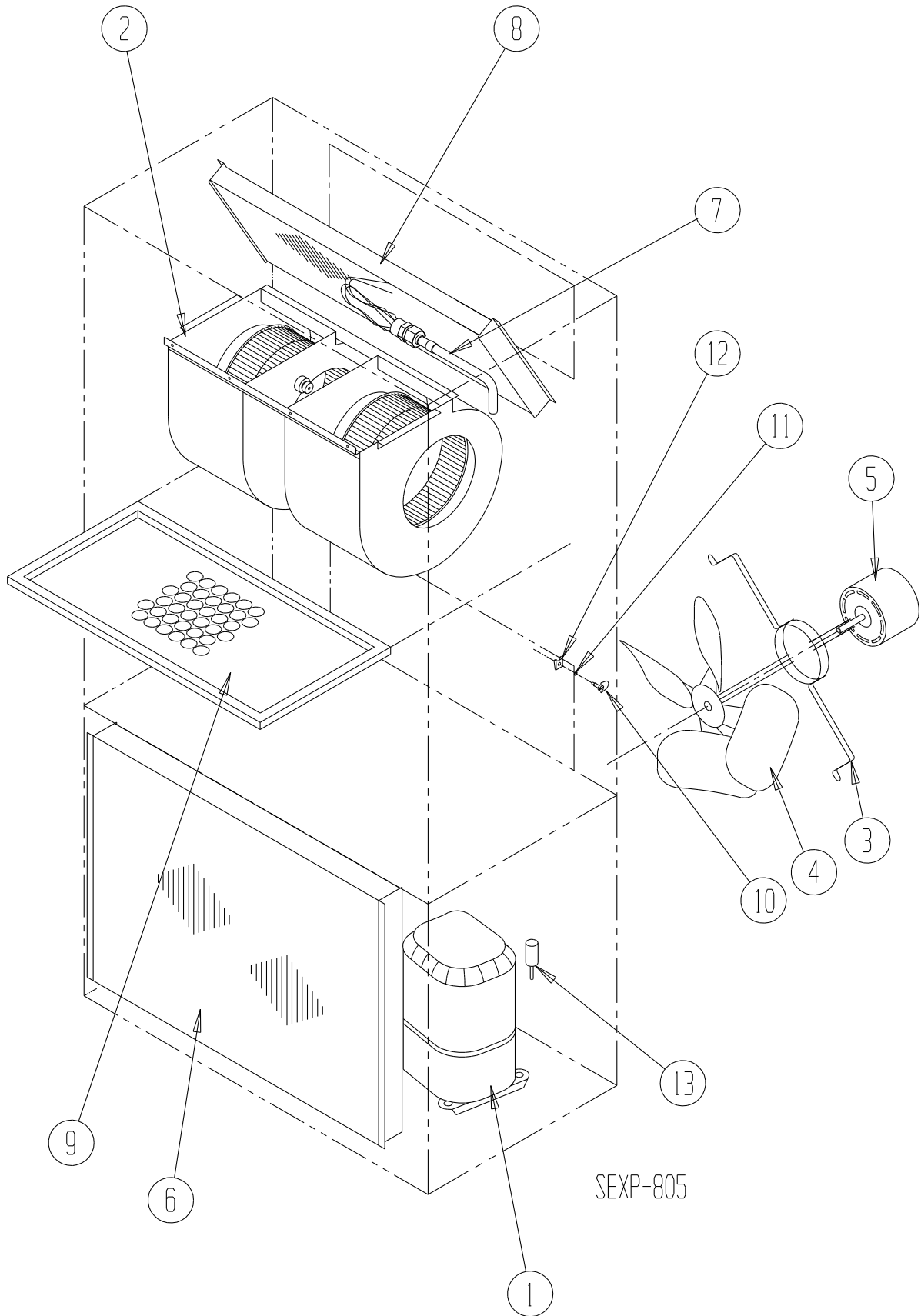

FUNCTIONAL COMPONENTS – RIGHT

Dwg No.	Part Number	Description	J18AA-A	J24AA-A	J24AA-B	J24AA-C
1	8000-313	Compressor	X			
1	8000-314	Compressor		X		
1	8000-315	Compressor			X	
1	8000-316	Compressor				X
2	S900-326	Blower Assembly		X	X	
2	S900-327	Blower Assembly				X
2	S900-291	Blower Assembly	X			
3	8200-001	Fan Motor Mount	X	X	X	X
4	5151-033	Fan Blade	X	X	X	
4	5151-046	Fan Blade				X
5	8103-016	Condenser Motor	X	X	X	
5	8103-020	Condenser Motor				X
6	5051-205BX	Condenser Coil	X			
6	5054-205BX	Condenser Coil – Coated	X			
6	5051-204BX	Condenser Coil		X	X	X
6	5054-204BX	Condenser Coil – Coated		X	X	X
7	800-0458	Distributor Assembly	X			
7	800-0459	Distributor Assembly		X	X	X
8	917-0276BX	Evaporator Coil with Distributor Assembly	X			
8	917-0283BX	Evaporator Coil – Coated with Distributor Assembly	X			
8	917-0277BX	Evaporator Coil with Distributor Assembly		X	X	X
8	917-0284BX	Evaporator Coil – Coated with Distributor Assembly		X	X	X
9	7004-011	Air Filter 1" Throw-Away (16x25x1)	X	X	X	X
9	7003-032	Air Filter 1" Washable ① (16x25x1)	O	O	O	O
9	7004-025	Air Filter 2" Pleated ① (16x25x2)	O	O	O	O
10	1171-022	1/4" Turn Fastener	X	X	X	X
11	1171-024	1/4" Turn Retainer	X	X	X	X
12	1171-023	1/4" Receptacle	X	X	X	X
13	8406-142	High Pressure Switch (Screw On)	X	X	X	X
13	8406-140	Low Pressure Switch (Screw On)	X	X	X	X
NS	CMA-28	Low Ambient Control (Screw On) ①		O	O	O
NS	5201-021	Filter Drier	X	X	X	X
NS	5451-024	Tubing Isolation Grommet	X	X	X	X
NS	6031-009	Coremax Value Core	X	X	X	X
NS	1171-028	Filter Door Clip	2	2	2	2
NS	1171-057	Filter Door Screw	2	2	2	2
NS	1171-027	Filter Door Screw Retainer	2	2	2	2

NS – Not Shown
 ① – Optional on these models

X – Standard
 O – Add-On Option

FUNCTIONAL COMPONENTS - LEFT

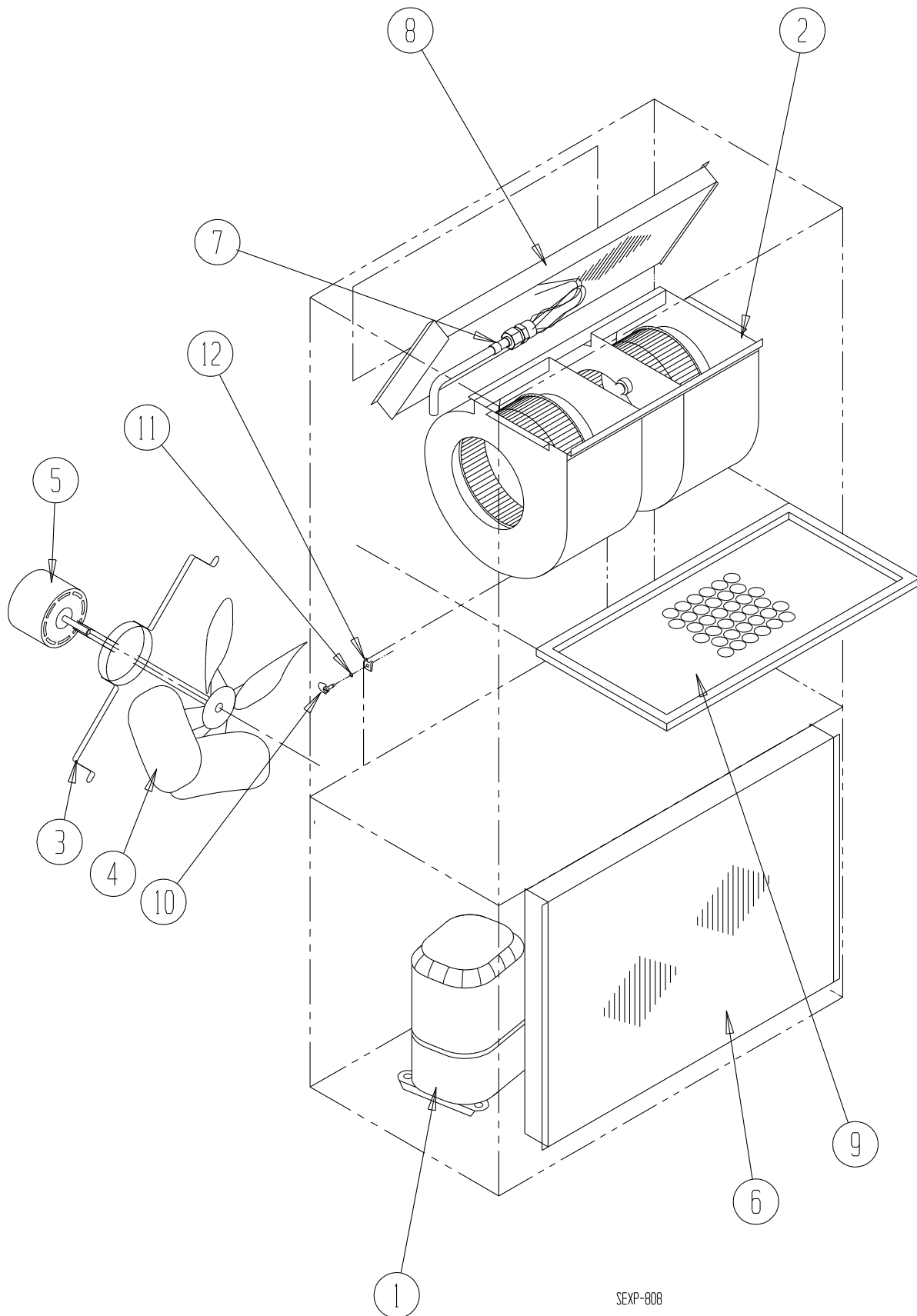

SEXP-808

FUNCTIONAL COMPONENTS – LEFT

Dwg No.	Part Number	Description	J18LA-A	J24LA-A	J24LA-B
1	8000-313	Compressor	X		
1	8000-314	Compressor		X	
1	8000-315	Compressor			X
2	S900-326	Blower Assembly		X	X
2	S900-291	Blower Assembly	X		
3	8200-001	Fan Motor Mount	X	X	X
4	5151-033	Fan Blade	X	X	X
5	8103-016	Condenser Motor	X	X	X
6	5051-205BX	Condenser Coil	X		
6	5054-205BX	Condenser Coil – Coated	X		
6	5051-204BX	Condenser Coil		X	X
6	5054-204BX	Condenser Coil – Coated		X	X
7	800-0458	Distributor Assembly	X		
7	800-0459	Distributor Assembly		X	X
8	917-0276BX	Evaporator Coil with Distributor Assembly	X		
8	917-0283BX	Evaporator Coil – Coated with Distributor Assembly	X		
8	917-0277BX	Evaporator Coil with Distributor Assembly		X	X
8	917-0284BX	Evaporator Coil – Coated with Distributor Assembly		X	X
9	7004-011	Air Filter 1" Throw-Away (16x25x1)	X	X	X
9	7003-032	Air Filter 1" Washable ① (16x25x1)	O	O	O
9	7004-025	Air Filter 2" Pleated ① (16x25x2)	O	O	O
10	1171-022	1/4" Turn Fastener	X	X	X
11	1171-024	1/4" Turn Retainer	X	X	X
12	1171-023	1/4" Receptacle	X	X	X
NS	8406-142	High Pressure Switch (Screw On)	X	X	X
NS	8406-140	Low Pressure Switch (Screw On)	X	X	X
NS	CMA-28	Low Ambient Control (Screw On) ①		O	O
NS	5201-021	Filter Drier	X	X	X
NS	5451-024	Tubing Isolation Grommet	X	X	X
NS	6031-009	Coremax Valve Core	X	X	X
NS	1171-028	Filter Door Clip	2	2	2
NS	1171-057	Filter Door Screw	2	2	2
NS	1171-027	Filter Door Screw Retainer	2	2	2

NS – Not Shown
 ① – Optional on these models

X – Standard
 O – Add-On Option

CONTROL PANEL - RIGHT

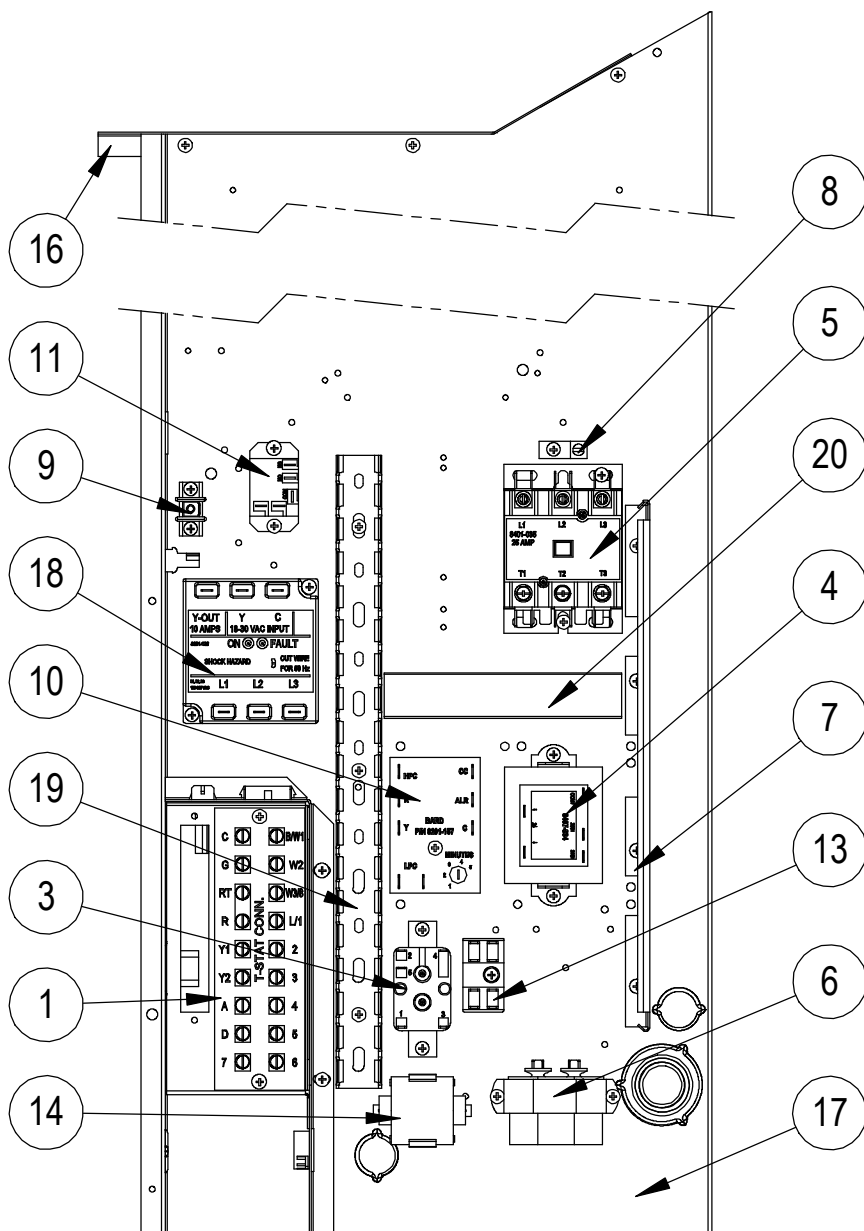

SEXP-851

CONTROL PANEL – RIGHT

Dwg No.	Part Number	Description	J18AA-A	J24AA-A	J24AA-B	J24AA-C
1	8607-044	Low Voltage Terminal Strip	X	X	X	X
3	8201-130	Blower Control Relay	2	X	X	X
3	8201-009	Blower Control Relay				
3	8201-032	Blower Control Relay				
4	8407-034	Transformer	X	X	X	X
4	8407-042	Transformer				
5	8401-033	Compressor Contactor	X	X	X	X
5	8401-035	Compressor Contactor				
6	8552-046	Compressor Capacitor	X	X	X	X
6	8552-051	Compressor Capacitor				
6	8552-002	Outdoor Motor Capacitor				
7	135-122	Wire Shield	X	X	X	X
8	8611-006	Ground Terminal	X	X	X	X
9	8607-041	Park Terminal	X			
10	8201-157	Compressor Control Module	X	X	X	X
11	8201-130	Alarm Relay (Optional)	X	X	X	X
13	8607-017	Terminal Block (Optional)	X	X	X	X
14	8551-004	Start Device (PTCR) (Optional)	X	X		
16	117X137	Control Panel Top	X	X	X	X
17	117X374	Control Panel	X	X	X	X
18	8201-126	Phase Monitor			X	X
19	8611-140-1400	Cable Duct	X	X	X	X
20	8611-140-0500	Cable Duct	X	X	X	X
NS	8615-035	Circuit Breaker 20A 2 Pole (Opt.) ①	X			
NS	8615-036	Circuit Breaker 25A 2 Pole (Opt.) ①		X		
NS	8615-067	Toggle Disconnect (Optional) ①				X
NS	8615-056	Circuit Breaker 15A 3 Pole (Opt.) ①			X	
NS	4095-189	Wiring Diagram	X			
NS	4095-185	Wiring Diagram		X		
NS	4095-262	Wiring Diagram			X	
NS	4095-362	Wiring Diagram				X
NS	3000-1224	Compressor Plug/Harness	X	X	X	X
NS	3000-1231	Compressor Plug/Harness				
NS	3000-017	Control Panel Harness	X	X	X	X
NS	3000-018	Control Panel Harness				
NS	3000-022	Control Panel Harness				
NS	3000-1494	Low Voltage Terminal Block Harness	X	X	X	X

NS – Not Shown

① Circuit breakers listed are for units without electric heat, "OZ" models. Hot gas bypass models not available without electric heat. See heater replacement parts manual for units with electric heat.

CONTROL PANEL - LEFT

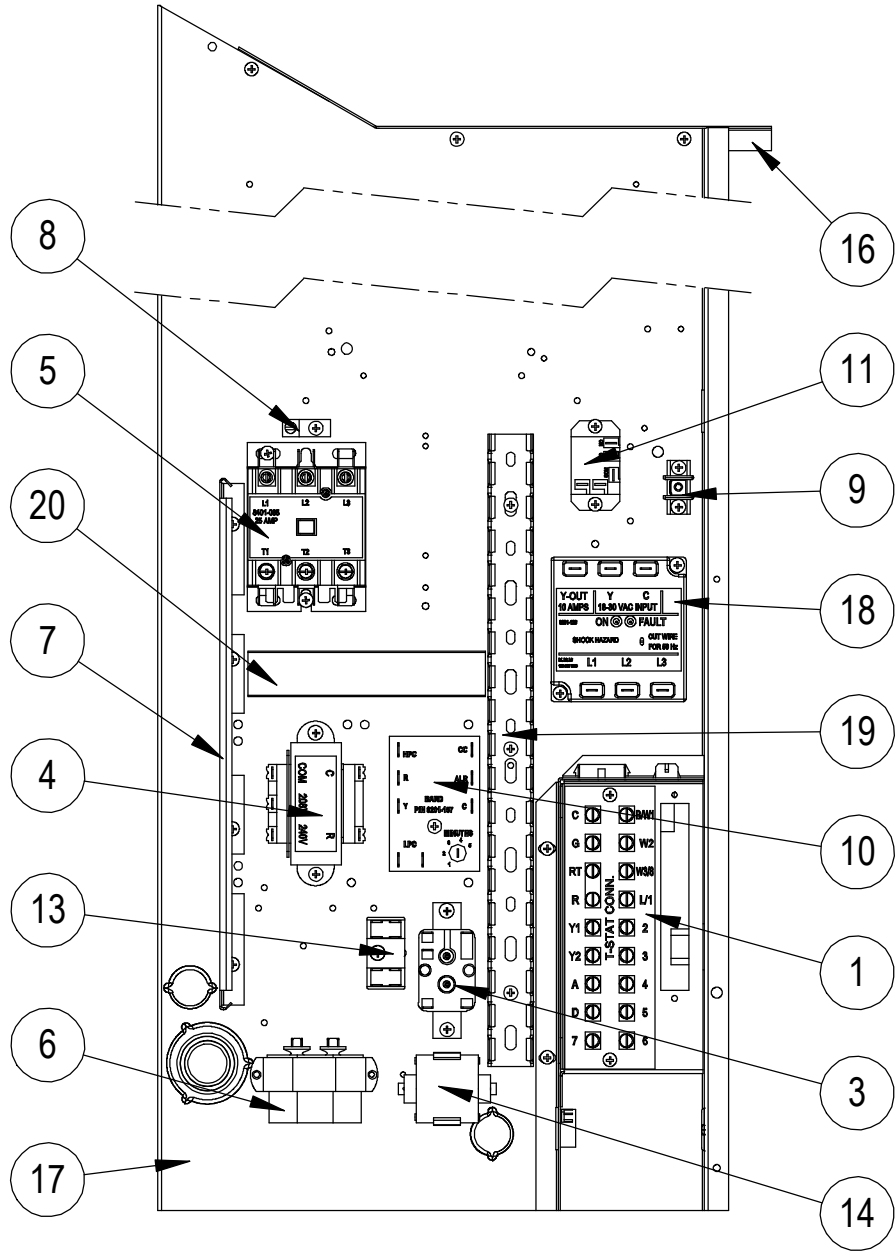

SEXP-852

CONTROL PANEL – LEFT

Dwg No.	Part Number	Description	J18LA-A	J24LA-A	J24LA-B
1	8607-044	Low Voltage Terminal Strip	X	X	X
3	8201-130	Blower Control Relay	2	X	
3	8201-009	Blower Control Relay			X
4	8407-034	Transformer	X	X	X
5	8401-033	Compressor Contactor	X	X	
5	8401-035	Compressor Contactor			X
6	8552-046	Compressor Capacitor	X		
6	8552-047	Compressor Capacitor		X	
6	8552-002	Outdoor Motor Capacitor			X
7	135-122	Wire Shield	X	X	X
8	8611-006	Ground Terminal	X	X	X
9	8607-041	Park Terminal	X		
10	8201-157	Compressor Control Module	X	X	X
11	8201-130	Alarm Relay (Optional)	X	X	X
13	8607-017	Terminal Block (Optional)	X	X	X
14	8551-004	Start Device (PTCR) (Optional)	X	X	X
16	117Y137	Control Panel Top	X	X	X
17	117Y374	Control Panel	X	X	X
18	8201-126	Phase Monitor			X
19	8611-140-1400	Cable Duct	X	X	X
20	8611-140-0500	Cable Duct	X	X	X
NS	8615-035	Circuit Breaker 20A 2 Pole (Opt.) ①	X		
NS	8615-036	Circuit Breaker 25A 2 Pole (Opt.) ①		X	
NS	8615-056	Circuit Breaker 15A 3 Pole (Opt.) ①			X
NS	4095-189	Wiring Diagram	X		
NS	4095-185	Wiring Diagram		X	
NS	4095-262	Wiring Diagram			X
NS	3000-1224	Compressor Plug/Harness	X	X	
NS	3000-1231	Compressor Plug/Harness			X
NS	3003-017	Control Panel Harness		X	
NS	3003-018	Control Panel Harness			X
NS	3003-020	Control Panel Harness	X		
NS	3000-1494	Low Voltage Terminal Block Harness	X	X	X

NS – Not Shown

① Circuit breakers listed are for units without electric heat, "OZ" models. Hot gas bypass models not available without electric heat. See heater replacement parts manual for units with electric heat.

BLOWER ASSEMBLY - RIGHT & LEFT

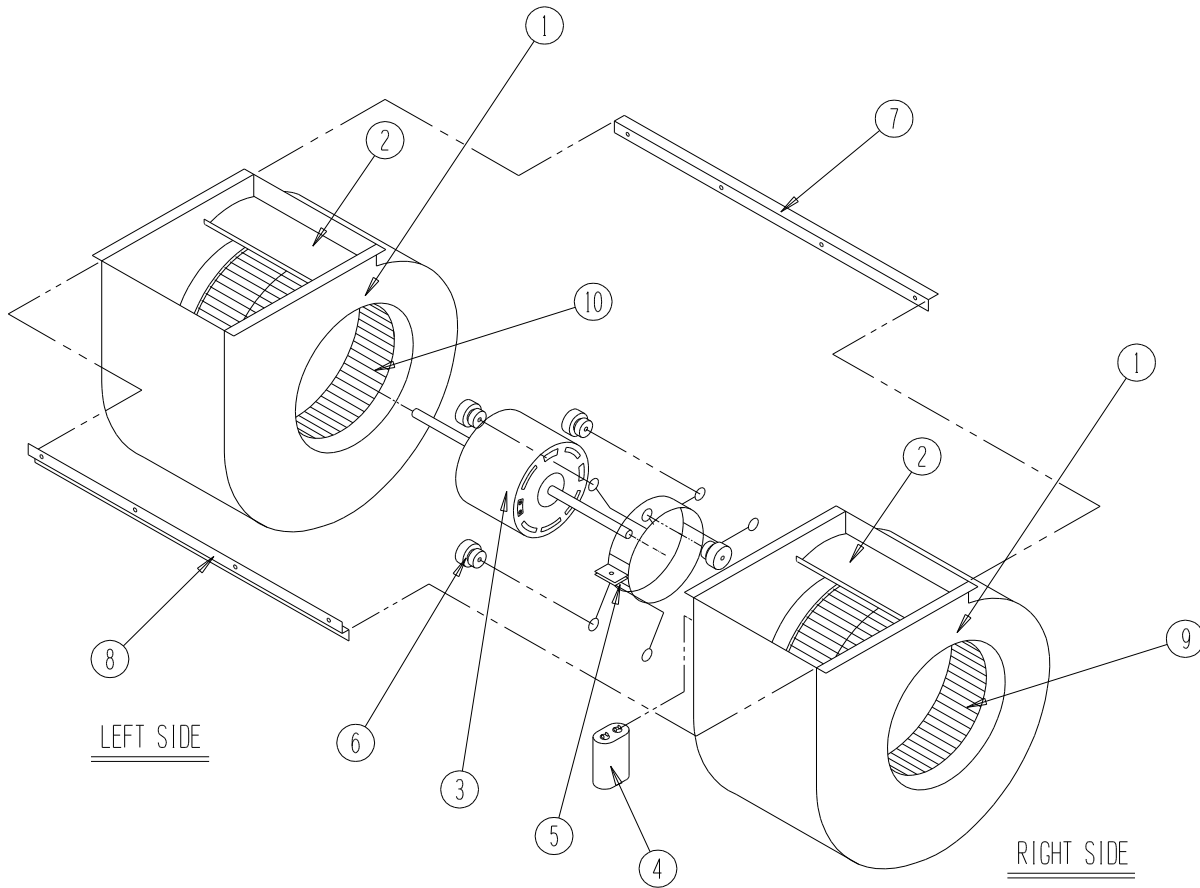

SEXP-346

Dwg No.	Part Number	Description	S900-326	S900-327	S900-291
1	151-115	Housing	2	2	2
2	144-183	Cutoff	X	X	X
3	8102-016	Blower Motor (230/208)	X		
3	8102-017	Blower Motor (460)		X	
3	8102-014	Blower Motor (230/208)			X
4	8552-002	Capacitor			X
4	8552-004	Capacitor	X	X	
5	8200-031	Motor Mount	X	X	X
6	5451-011	Grommets	6	6	6
7	105-1061	Back Brace	X	X	X
8	103-435	Front Brace	X	X	X
9	5152-092	Wheel 9-6 CW	X	X	X
10	5152-093	Wheel 9-6 CCW	X	X	X