REPLACEMENT PARTS MANUAL

WALL MOUNTED PACKAGE AIR CONDITIONER

Models:

J30AA-A	J30LA-A	J36AA-A	J36LA-A
J30AA-B	J30LA-B	J36AA-B	J36LA-B
J30AA-C	J30LA-C	J36AA-C	J36LA-C

Contents

<u>Description</u>	<u>Page</u>	<u>Description</u>	<u>Page</u>
Cabinet Components – Right Hand Models		Blower Assembly – Right & Left Hand Models	
♦ Exploded View	2	♦ Exploded View	14
♦ Usage List	3	♦ Usage List	14
Cabinet Components – Left Hand Models			
♦ Exploded View	4		
♦ Usage List	5		
Functional Components – Right Hand Models			
♦ Exploded View	6		
♦ Usage List	7		
Functional Components – Left Hand Models			
♦ Exploded View	8		
♦ Usage List	9		
Control Panel – Right Hand Models			
♦ Exploded View	10		
♦ Usage List	11		
Control Panel – Left Hand Models			
♦ Exploded View	12		
♦ Usage List	13		

General Notes

- Revised and/or additional pages may be issued from time to time.
- A complete and current manual consists of pages shown in the following contents section.

Important

- Contact the installing and/or local Bard distributor for all parts requirements. Make sure to have the complete model and serial number available from the unit rating plates.



Manual: 2110-1433D
Supersedes: 2110-1433C
Date: 6-19-19

CABINET COMPONENTS - RIGHT

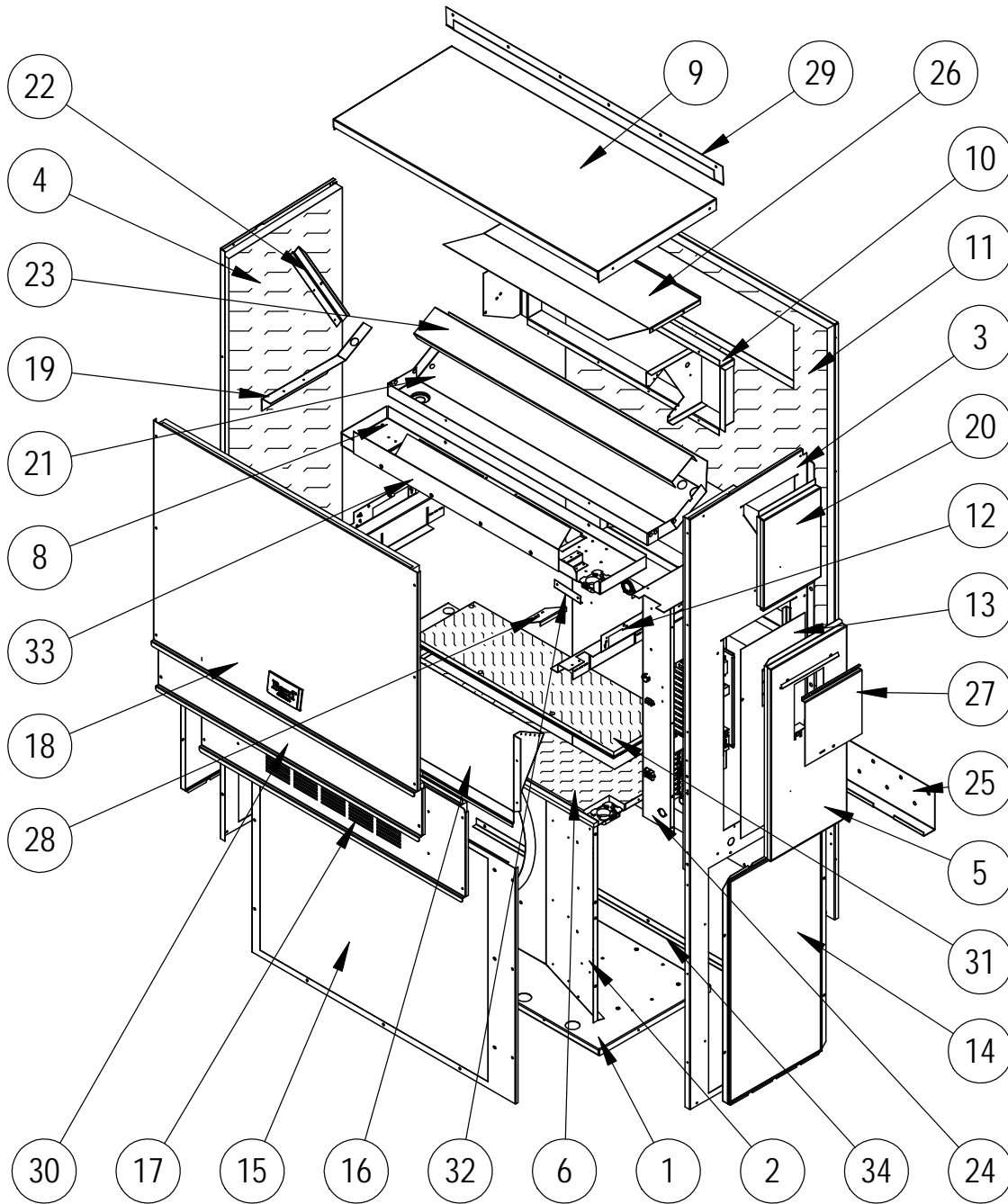

SEXP-799

CABINET COMPONENTS – RIGHT

Dwg No.	Part Number	Description	J30AA-A, B	J30AA-C	J36AA-A, B	J36AA-C
1	S127-471	Lower Base	X	X	X	X
2	125-081	Fan Shroud	X	X	X	X
3	S501-933-X	Right Side	X	X	X	X
4	S501-934-X	Left Side	X	X	X	X
5	S533-228	Control Panel Cover (Outer)	X	X	X	X
6	S521X527	Condenser Partition	X	X	X	X
8	121X467	Blower Partition	X	X	X	X
9	S507-308-X	Top	X	X	X	X
10	S111X030	Outlet Air Frame Assembly	X	X	X	X
11	S508-343	Back	X	X	X	X
12	113X480	Filter Bracket	2	2	2	2
13	S132-104	Control Panel Cover (Inner)	X		X	
13	S132-172	Control Panel Cover (Inner)		X		X
14	118-124-X	Side Grille	2	2	2	2
15	118-103-X	Condenser Grille	X	X	X	X
16	BFAD-3	Fresh Air Damper Assembly	X	X	X	X
17	S553-523-X	Vent Option Door	X	X	X	X
17	S553-540	Vent Option Door with ERV	X	X	X	X
18	S514-264-X	Upper Front	X	X	X	X
19	105X850	Side Support	X	X	X	X
20	S543-175-X	Right Side Cover Plate (Outer)	X	X	X	X
21	S123-127	Drain Pan	X	X	X	X
22	147-044	Evaporator Support	X	X	X	X
23	137-685	Bottom Evaporator Fill	X	X	X	X
24	Control Panel Assembly	See Control Panel Assy. Drawing & Parts List Assy.	X	X	X	X
25	113-140	Bottom Mounting Bracket	X	X	X	X
26	135X123	Heat Shield	X	X	X	X
27	S153-218	Disconnect Access Door	X	X	X	X
28	137-259	Fill Plate	X	X	X	X
29	113-149-X	Top Rain Flashing	X	X	X	X
30	S553-524-X	Filter Door	X	X	X	X
31	S536-498	Cond. Partition Block Off Plate	X	X	X	X
32	105-1302	Grommet Retainer	X	X	X	X
33	135-329	Air Baffle	X	X	X	X
34	105-1393	Close Off Angle	X	X	X	X

CABINET COMPONENTS - LEFT

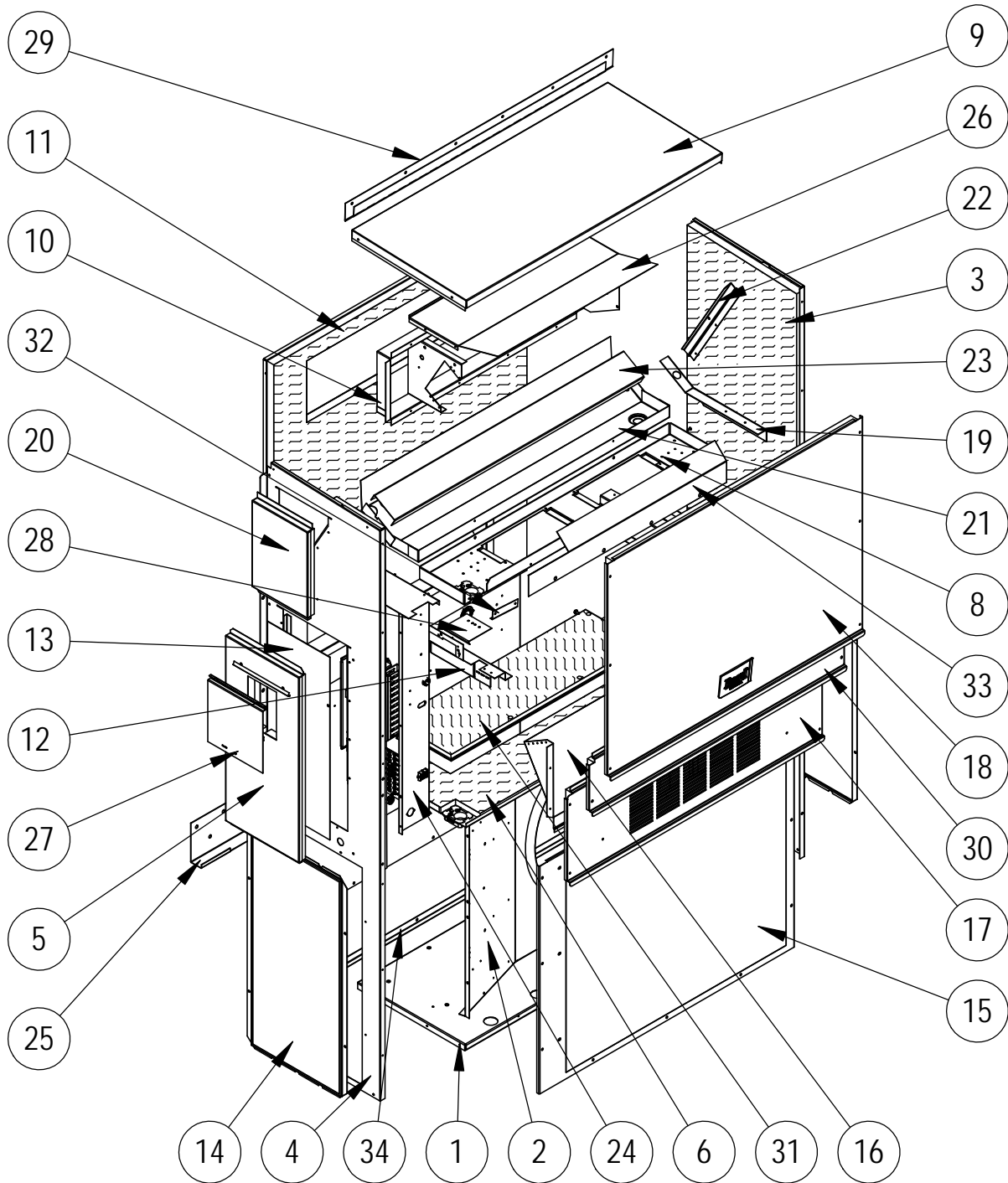

SEXP-802

CABINET COMPONENTS - LEFT

Dwg No.	Part Number	Description	J30LA-A, B	J30LA-C	J36LA-A, B	J36LA-C
1	S127-472	Lower Base	X	X	X	X
2	125-081	Fan Shroud	X	X	X	X
3	S501-935-X	Right Side	X	X	X	X
4	S501-936-X	Left Side	X	X	X	X
5	S533-228	Control Panel Cover (Outer)	X	X	X	X
6	S521Y527	Condenser Partition	X	X	X	X
8	121Y467	Blower Partition	X	X	X	X
9	S507-308-X	Top	X	X	X	X
10	S111Y030	Outlet Air Frame Assembly	X	X	X	X
11	S508-343	Back	X	X	X	X
12	113Y480	Filter Bracket	2	2	2	2
13	S132-104	Control Panel Cover (Inner)	X		X	
13	S132-172	Control Panel Cover (Inner)		X		X
14	118-124-X	Side Grille	2	2	2	2
15	118-104-X	Condenser Grille	X	X	X	X
16	BFAD-3	Fresh Air Damper Assembly	X	X	X	X
17	S553-523-X	Vent Option Door	X	X	X	X
18	S514-264-X	Upper Front	X	X	X	X
19	105Y850	Side Support	X	X	X	X
20	S543-175-X	Right Side Cover Plate (Outer)	X	X	X	X
21	S123-130	Drain Pan	X	X	X	X
22	147-044	Evaporator Support	X	X	X	X
23	137-685	Bottom Evaporator Fill	X	X	X	X
24	Control Panel Assembly	See Control Panel Assy. Drawing & Parts List Assy.	X	X	X	X
25	113-140	Bottom Mounting Bracket	X	X	X	X
26	135Y123	Heat Shield	X	X	X	X
27	S153-218	Disconnect Access Door	X	X	X	X
28	137-259	Fill Plate	X	X	X	X
29	113-149-X	Top Rain Flashing	X	X	X	X
30	S553-524-X	Filter Door	X	X	X	X
31	S536-498	Cond. Partition Block Off Plate	X	X	X	X
32	105-1302	Grommet Retainer	X	X	X	X
33	135-329	Air Baffle	X	X	X	X
34	105-1393	Close Off Angle	X	X	X	X

FUNCTIONAL COMPONENTS - RIGHT

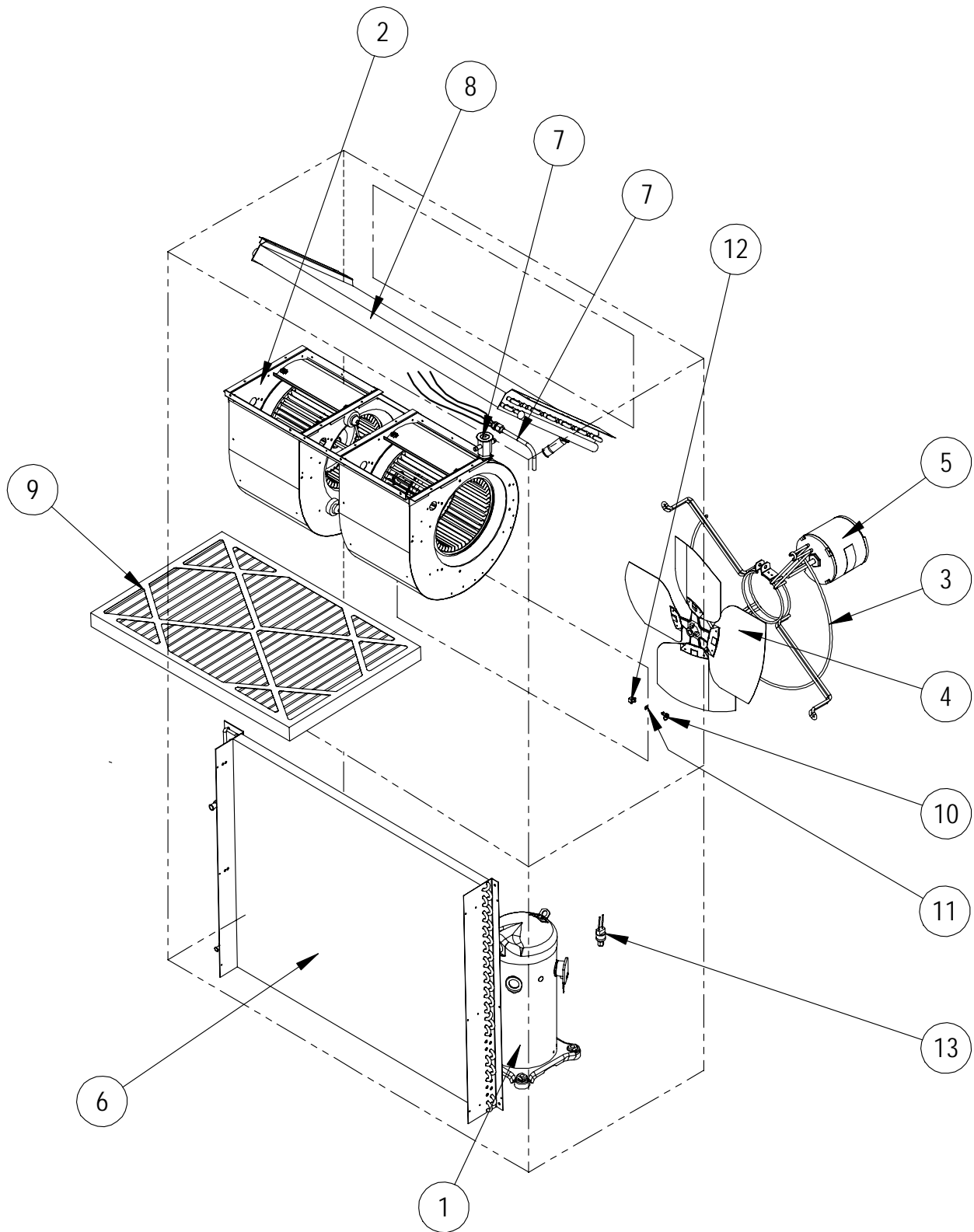

SEXP-177 A

FUNCTIONAL COMPONENTS – RIGHT

Dwg No.	Part Number	Description	J30AA-A	J30AA-B	J30AA-C	J36AA-A	J36AA-B	J36AA-C
1	8000-346	Compressor	X					
1	8000-347	Compressor		X				
1	8000-348	Compressor			X			
1	8000-309	Compressor				X		
1	8000-310	Compressor					X	
1	8000-311	Compressor						X
2	S900-231	Blower Assembly	X	X		X	X	
2	S900-232	Blower Assembly			X			X
3	8200-001	Fan Motor Mount	X	X	X	X	X	X
4	5151-045	Fan Blade	X	X	X	X	X	X
5	8103-029	Condenser Motor	X	X		X	X	
5	8103-030	Condenser Motor			X			X
6	5051-203BX	Condenser Coil	X	X	X			
6	5054-203BX	Condenser Coil - Coated	X	X	X			
6	5051-202BX	Condenser Coil				X	X	X
6	5054-202BX	Condenser Coil - Coated				X	X	X
7	800-0456	Distributor Assembly				X	X	X
7	800-0457	Distributor Assembly	X	X	X			
8	917-0275BX	Evaporator Coil w/Distributor Assy.	X	X	X			
8	917-0285BX	Evaporator Coil - Coated w/Distributor Assy.	X	X	X			
8	917-0274BX	Evaporator Coil w/Distributor Assy.				X	X	X
8	917-0287BX	Evaporator Coil - Coated w/Distributor Assy.				X	X	X
9	7004-026	Air Filter 2" Pleated (16x30x2)	X	X	X	X	X	X
9	7004-019	Air Filter 1" Throw-Away ① (16x30x1)	0	0	0	0	0	0
9	7003-031	Air Filter 1" Washable ① (16x30x1)	0	0	0	0	0	0
10	1171-022	1/4" Turn Fastener	X	X	X	X	X	X
11	1171-024	1/4" Turn Retainer	X	X	X	X	X	X
12	1171-023	1/4" Receptacle	X	X	X	X	X	X
13	8406-142	High Pressure Switch (Screw On)	X	X	X	X	X	X
NS	8406-140	Low Pressure Switch (Screw On)	X	X	X	X	X	X
NS	CMA-28	Low Ambient Control (Screw On) ①	0	0	0	0	0	0
NS	5201-021	Filter Drier	X	X	X	X	X	X
NS	5451-024	Tubing Isolation Grommet	2	2	2	2	2	2
NS	6031-009	Coremax Valve Core	2	2	2	2	2	2
NS	1171-028	Filter Door Clip	2	2	2	2	2	2
NS	1171-057	Filter Door Screw	2	2	2	2	2	2
NS	1171-027	Filter Door Screw Retainer	2	2	2	2	2	2

NS – Not Shown

① – Optional on these models

X – Standard

0 – Add-On Option

FUNCTIONAL COMPONENTS - LEFT

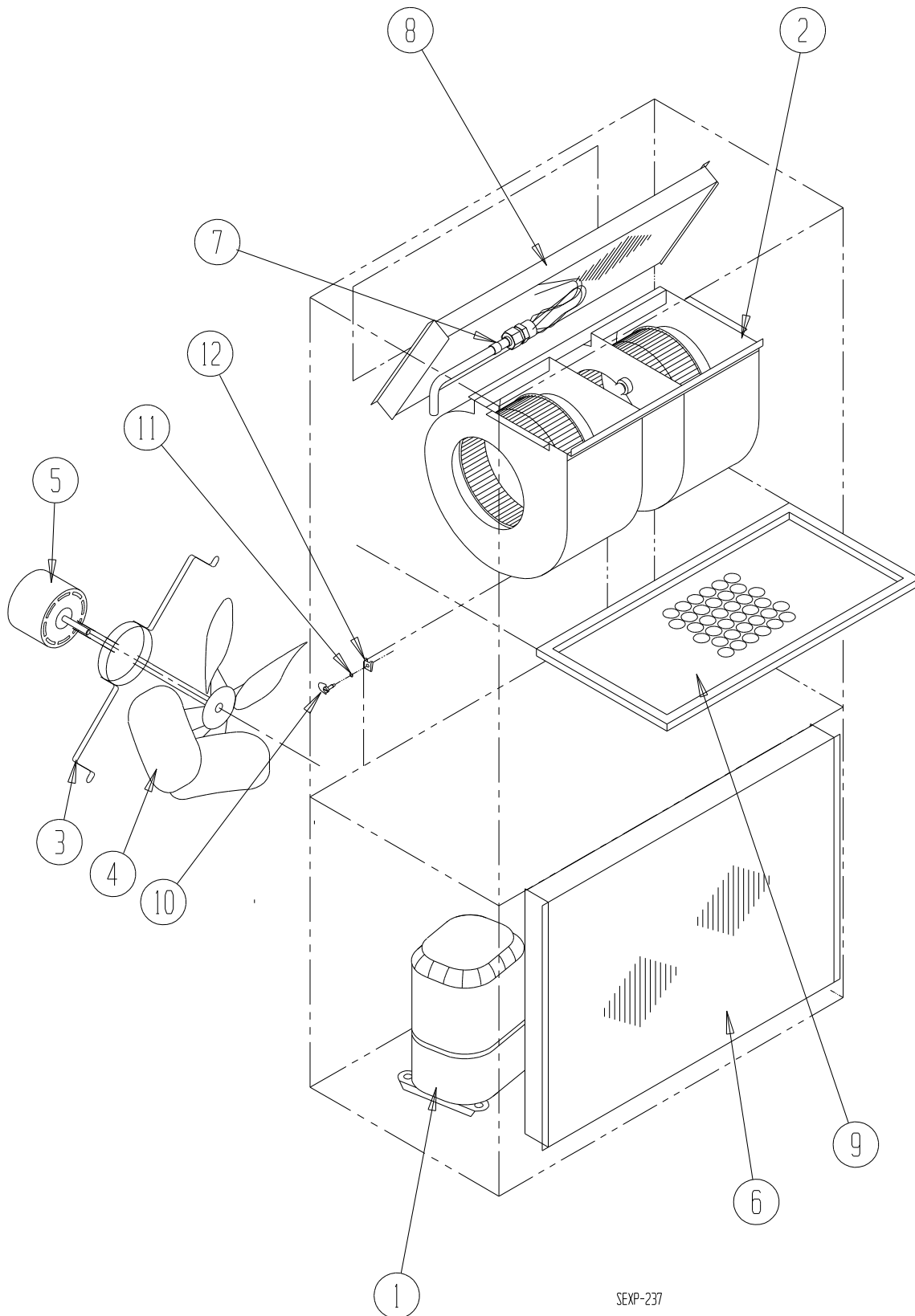

SEXP-237

FUNCTIONAL COMPONENTS – LEFT

Dwg No.	Part Number	Description	J30LA-A	J30LA-B	J30LA-C	J36LA-A	J36LA-B	J36LA-C
1	8000-346	Compressor	X					
1	8000-347	Compressor		X				
1	8000-348	Compressor			X			
1	8000-309	Compressor				X		
1	8000-310	Compressor					X	
1	8000-311	Compressor						X
2	S900-231	Blower Assembly	X	X		X	X	
2	S900-232	Blower Assembly			X			X
3	8200-001	Fan Motor Mount	X	X	X	X	X	X
4	5151-045	Fan Blade	X	X	X	X	X	X
5	8103-029	Condenser Motor	X	X		X	X	
5	8103-030	Condenser Motor			X			X
6	5051-203BX	Condenser Coil	X	X	X			
6	5054-203BX	Condenser Coil – Coated	X	X	X			
6	5051-202BX	Condenser Coil				X	X	X
6	5054-202BX	Condenser Coil – Coated				X	X	X
7	800-0456	Distributor Assembly				X	X	X
7	800-0457	Distributor Assembly	X	X	X			
8	917-0275BX	Evaporator Coil w/Distributor Assy.	X	X	X			
8	917-0285BX	Evaporator Coil – Coated w/Distributor Assy.	X	X	X			
8	917-0274BX	Evaporator Coil w/Distributor Assy.				X	X	X
8	917-0287BX	Evaporator Coil – Coated w/Distributor Assy.				X	X	X
9	7004-026	Air Filter 2" Pleated (16x30x2)	X	X	X	X	X	X
9	7004-019	Air Filter 1" Throw-Away ① (16x30x1)	O	O	O	O	O	O
9	7003-031	Air Filter 1" Washable ① (16x30x1)	O	O	O	O	O	O
10	1171-022	1/4" Turn Fastener	X	X	X	X	X	X
11	1171-024	1/4" Turn Retainer	X	X	X	X	X	X
12	1171-023	1/4" Receptacle	X	X	X	X	X	X
NS	8406-142	High Pressure Switch (Screw On)	X	X	X	X	X	X
NS	8406-140	Low Pressure Switch (Screw On)	X	X	X	X	X	X
NS	CMA-28	Low Ambient Control (Screw On) ①	O	O	O	O	O	O
NS	5201-021	Filter Drier	X	X	X	X	X	X
NS	5451-024	Tubing Isolation Grommet	X	X	X	X	X	X
NS	6031-009	Coremax Valve Core	X	X	X	X	X	X
NS	1171-028	Filter Door Clip	X	X	X	X	X	X
NS	1171-057	Filter Door Screw	X	X	X	X	X	X
NS	1171-027	Filter Door Screw Retainer	X	X	X	X	X	X

NS – Not Shown

① – Optional on these models

X – Standard

O – Add-On Option

CONTROL PANEL - RIGHT

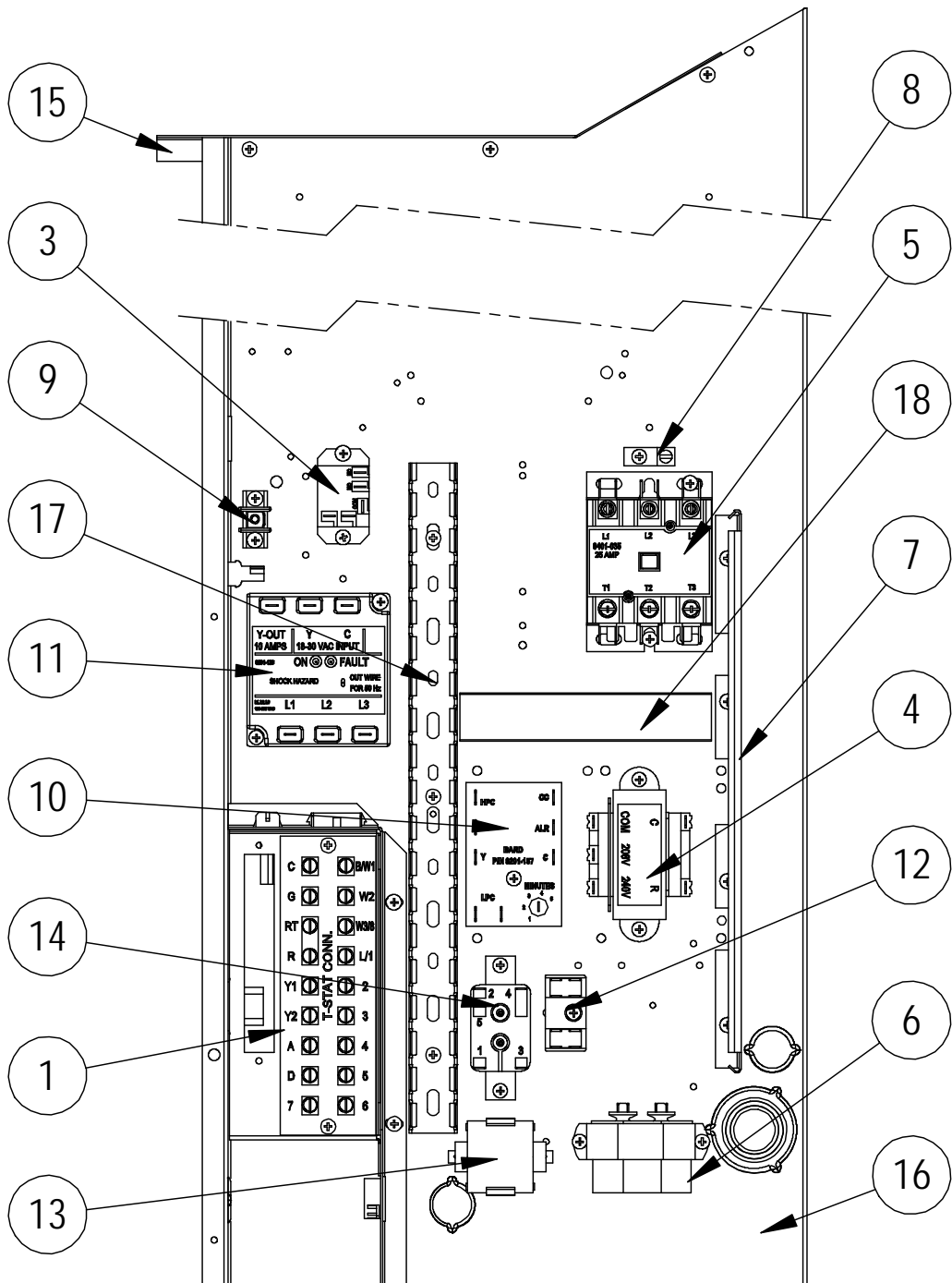

SEXP-853

CONTROL PANEL – RIGHT

Dwg No.	Part Number	Description	J30AA-A	J30AA-B	J30AA-C	J36AA-A	J36AA-B	J36AA-C
1	8607-044	Low Voltage Terminal Strip	X	X	X	X	X	X
3	8201-130	Blower Control Relay	X			X		
3	8201-009	Blower Control Relay		X			X	
3	8201-032	Blower Control Relay			X			X
4	8407-068	Transformer	X	X		X	X	
4	8407-069	Transformer			X			X
5	8401-033	Compressor Contactor	X			X		
5	8401-035	Compressor Contactor		X	X		X	X
6	8552-052	Compressor Capacitor	X			X		
6	8552-002	Outdoor Motor Capacitor		X	X		X	X
7	135-122	Wire Shield	X	X	X	X	X	X
8	8611-006	Ground Terminal	X	X	X	X	X	X
9	8607-041	Park Terminal	X	X	X	X	X	X
10	8201-164	Compressor Control Module	X	X	X	X	X	X
11	8201-126	Phase Monitor		X	X		X	X
12	8607-017	Terminal Block (Optional)	X	X	X	X	X	X
13	8551-004	Start Device (PTCR) (Optional)	X			X		
14	8201-062	Alarm Relay (Optional)	X	X	X	X	X	X
15	117X137	Control Panel Top	X	X	X	X	X	X
16	117X374	Control Panel	X	X	X	X	X	X
17	8611-140-1400	Cable Duct	X	X	X	X	X	X
18	8611-140-0500	Cable Duct	X	X	X	X	X	X
NS	8615-038	Circuit Breaker 35A 2 Pole (Opt.) ①	X			X		
NS	8615-054	Circuit Breaker 20A 3 Pole (Opt.) ①		X				
NS	8615-052	Circuit Breaker 30A 3 Pole (Opt.) ①					X	
NS	8615-067	Toggle Disconnect (Optional) ①			X			X
NS	4095-185	Wiring Diagram	X			X		
NS	4095-262	Wiring Diagram		X			X	
NS	4095-362	Wiring Diagram			X			X
NS	3000-1224	Compressor Plug/Harness	X			X		
NS	3000-1231	Compressor Plug/Harness		X	X		X	X
NS	3003-017	Control Panel Harness	X			X		
NS	3003-018	Control Panel Harness		X	X		X	X
NS	3000-1494	Low Voltage Terminal Block Harness	X	X	X	X	X	X

NS – Not Shown

① Circuit breakers listed are for units without electric heat, “OZ” models. Hot gas bypass models not available without electric heat. See heater replacement parts manual for units with electric heat.

CONTROL PANEL - LEFT

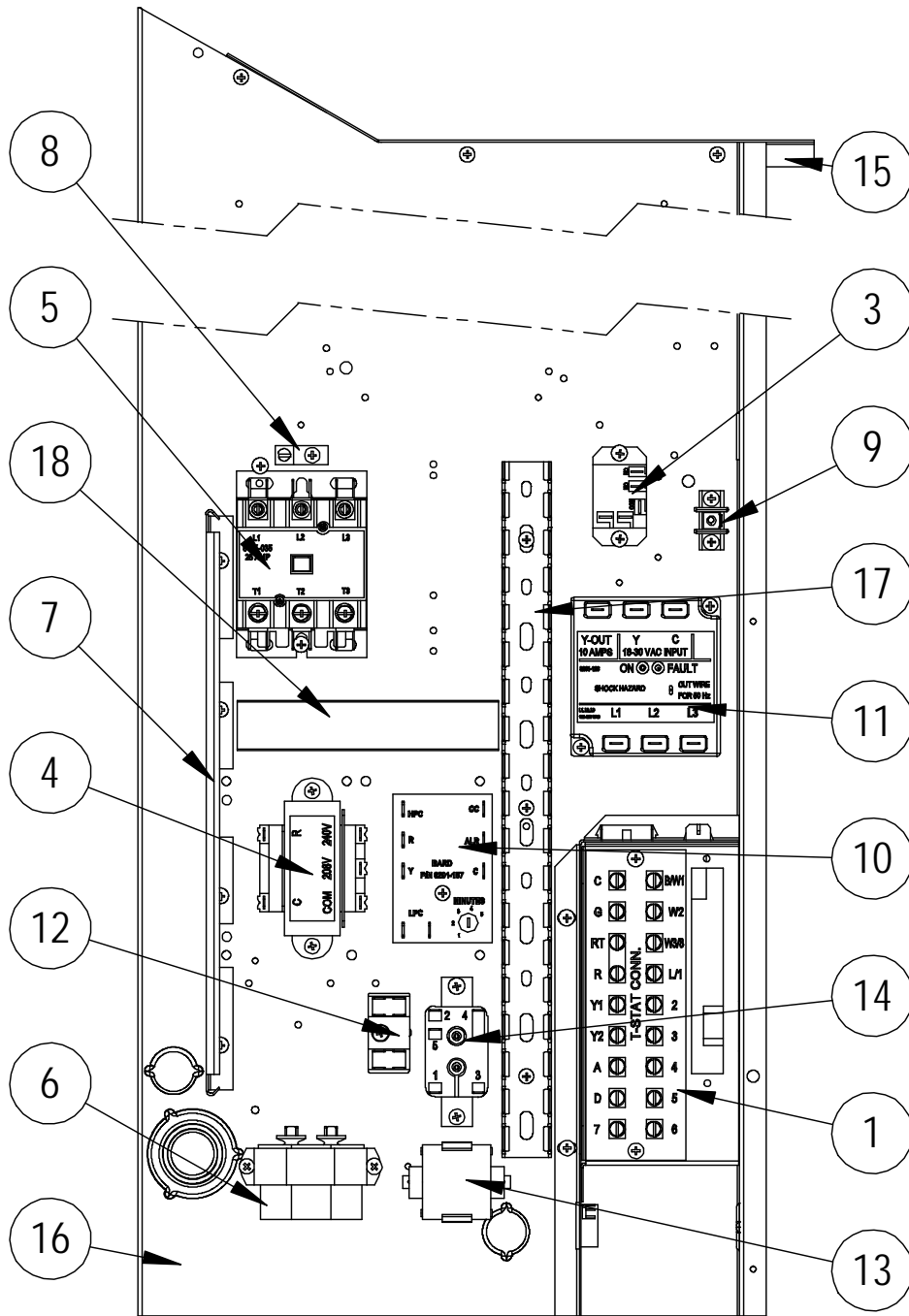

SEXP-854

CONTROL PANEL – LEFT

Dwg No.	Part Number	Description	J30LA-A	J30LA-B	J30LA-C	J36LA-A	J36LA-B	J36LA-C
1	8607-044	Low Voltage Terminal Strip	X	X	X	X	X	X
3	8201-130	Blower Control Relay	X			X		
3	8201-009	Blower Control Relay		X			X	
3	8201-032	Blower Control Relay			X			X
4	8407-068	Transformer	X	X		X	X	
4	8407-069	Transformer			X			X
5	8401-033	Compressor Contactor	X			X		
5	8401-035	Compressor Contactor		X	X		X	X
6	8552-052	Compressor Capacitor	X			X		
6	8552-002	Outdoor Motor Capacitor		X	X		X	X
7	135-122	Wire Shield	X	X	X	X	X	X
8	8611-006	Ground Terminal	X	X	X	X	X	X
9	8607-041	Park Terminal	X	X	X	X	X	X
10	8201-164	Compressor Control Module	X	X	X	X	X	X
11	8201-126	Phase Monitor		X	X		X	X
12	8607-017	Terminal Block (Optional)	X	X	X	X	X	X
13	8551-004	Start Device (PTCR) (Optional)	X	X	X	X	X	X
14	8201-062	Alarm Relay (Optional)	X	X	X	X	X	X
15	117Y137	Control Panel Top	X	X	X	X	X	X
16	117Y374	Control Panel	X	X	X	X	X	X
17	8611-140-1400	Cable Duct	X	X	X	X	X	X
18	8611-140-0500	Cable Duct	X	X	X	X	X	X
NS	8615-038	Circuit Breaker 35A 2 Pole (Opt.) ①	X			X		
NS	8615-054	Circuit Breaker 20A 3 Pole (Opt.) ①		X				
NS	8615-052	Circuit Breaker 30A 3 Pole (Opt.) ①					X	
NS	8615-067	Toggle Disconnect (Optional) ①			X			X
NS	4095-185	Wiring Diagram	X			X		
NS	4095-262	Wiring Diagram		X			X	
NS	4095-362	Wiring Diagram			X			X
NS	3000-1224	Compressor Plug/Harness	X			X		
NS	3000-1231	Compressor Plug/Harness		X	X		X	X
NS	3003-017	Control Panel Harness	X			X		
NS	3003-018	Control Panel Harness		X	X		X	X
NS	3000-1494	Low Voltage Terminal Block Harness	X	X	X	X	X	X

NS – Not Shown

① Circuit breakers listed are for units without electric heat, “OZ” models. Hot gas bypass models not available without electric heat. See heater replacement parts manual for units with electric heat.

BLOWER ASSEMBLY - RIGHT & LEFT

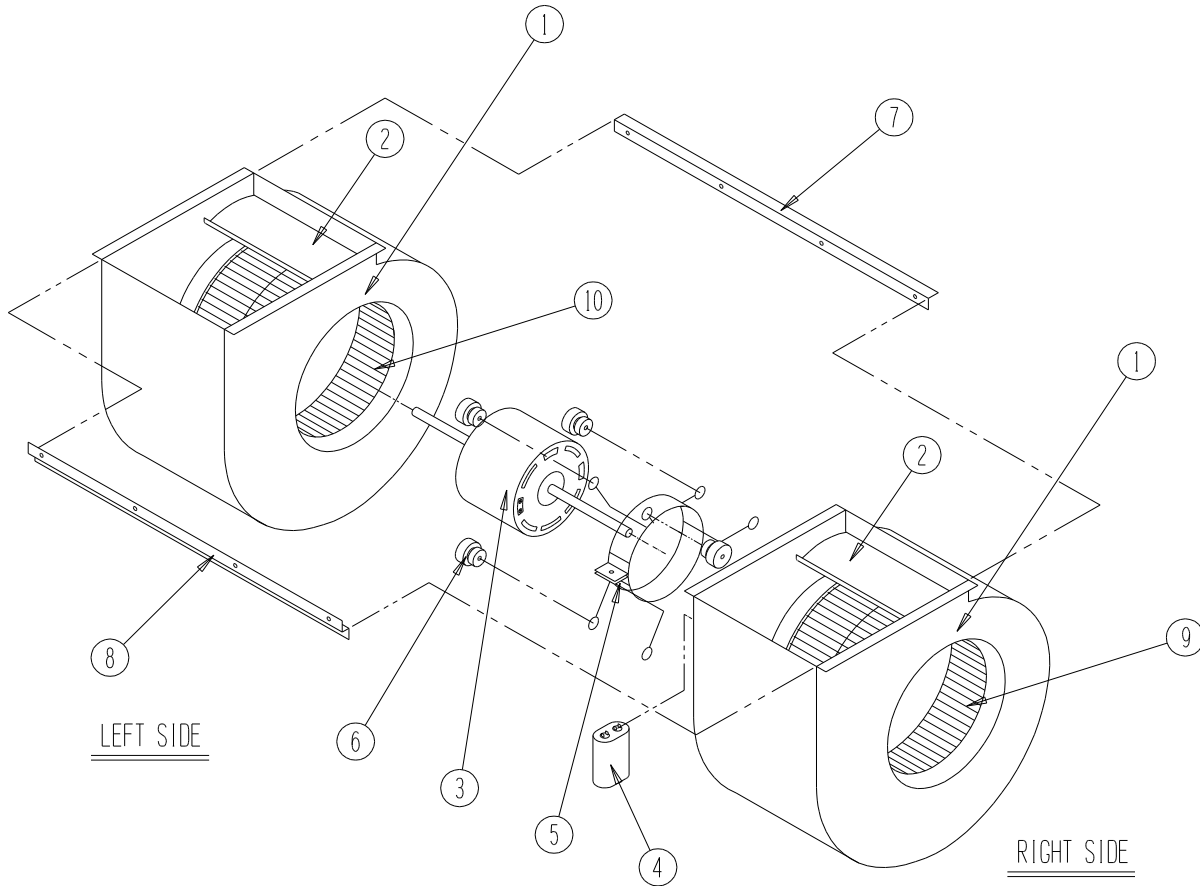

SEXP-346

Dwg No.	Part Number	Description	S900-231	S900-232
1	151-111	Housing	2	2
2	144-174	Cutoff	X	X
3	8105-029	Blower Motor (230/208)	X	
3	8105-033	Blower Motor (460)		X
4	8552-002	Capacitor	X	X
5	8200-031	Motor Mount	X	X
6	5451-011	Grommets	6	6
7	105-870	Back Brace	X	X
8	103-401	Front Brace	X	X
9	5152-090	Wheel CW	X	X
10	5152-091	Wheel CCW	X	X