

---

# REPLACEMENT PARTS MANUAL

---

## DC FREE COOLING UNIT SYSTEM

### AIR CONDITIONER MODELS

D25A2PA D35A2PA  
D25L2PA D35L2PA  
D35A2PB  
D35L2PB

### CONTROLLER MODELS

LC1000 LC1500 LC2000

---

Description	Page
Cabinet Components	
♦ Exploded View .....	2
♦ Usage List .....	3
Functional Components	
♦ Exploded View .....	4
♦ Usage List .....	5
Control Panel – Right Hand	
♦ Layout View .....	6
♦ Usage List .....	7
Control Panel – Left Hand	
♦ Layout View .....	8
♦ Usage List .....	9
Blower Assembly	
♦ Exploded View .....	10
♦ Usage List .....	10
DC Freecooling	
♦ Exploded View .....	11
♦ Usage List .....	11
DC Freecooling Air Hood	
♦ Exploded View .....	12
♦ Usage List .....	12

---

Description	Page
DC Freecooling Damper Motor	
♦ Exploded View .....	13
♦ Usage List .....	13
Bard-Link™ PLC Lead/Lag Controller	
♦ Layout View .....	14
♦ Usage List .....	14

### General Notes

- Revised and/or additional pages may be issued from time to time.
- A complete and current manual consists of pages shown in the following contents section.

### Important

- Contact the installing and/or local Bard distributor for all parts requirements. Make sure to have the complete model and serial number available from the unit rating plates.



Bard Manufacturing Company, Inc.  
Bryan, Ohio 43506  
www.bardhvac.com

Manual: 2110-1434  
Supersedes: **NEW**  
Date: 9-1-16

# CABINET COMPONENTS

---

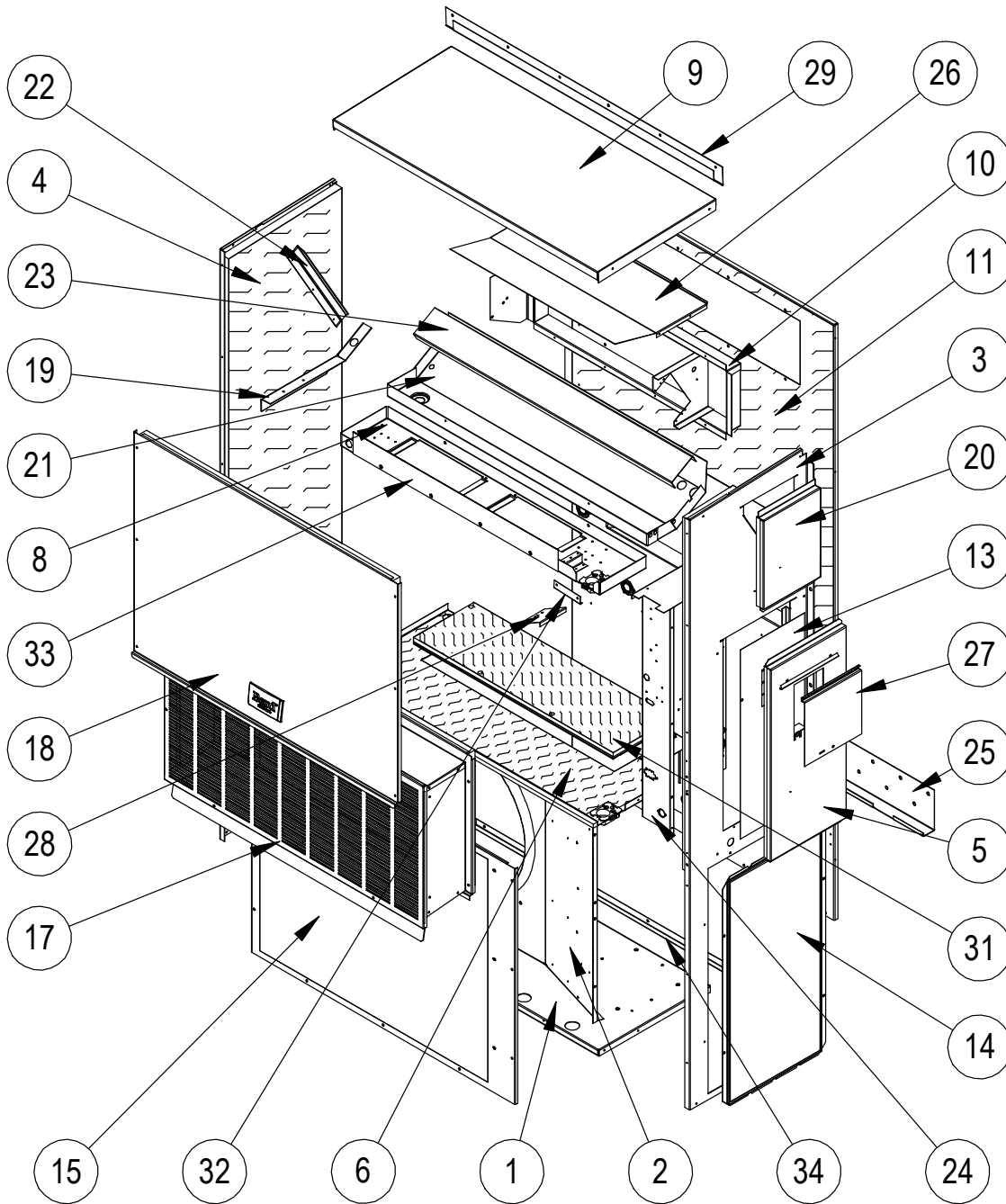

SEXP-860

# CABINET COMPONENTS

Dwg No.	Part Number	Description	D25A2PA	D35A2PA, B
1	S127-471	Lower Base	X	X
2	125-081	Fan Shroud	X	X
3	S501-977-* ①	Right Side	X	X
4	S501-934-* ①	Left Side	X	X
5	S533-285 ①	Control Panel Cover (Outer)	X	X
6	S521X527	Condenser Partition	X	X
8	121X541	Blower Partition	X	X
9	S507-308-* ①	Top	X	X
10	S111X247	Outlet Air Frame Assembly	X	X
11	S508-343	Back	X	X
13	S132-283	Control Panel Cover (Inner)	X	X
14	118-105-* ①	Side Grille	2	2
15	118-103-* ①	Condenser Grille	X	X
17	S553-660-* ①	Hood Assembly (see <b>DC Freecooling Air Hood</b> on page 12)	X	X
18	S514-241-* ①	Upper Front	X	X
19	105X850	Side Support	X	X
20	S543-175-* ①	Heater Access Cover	X	X
21	S123-127	Drain Pan	X	X
22	147-044	Evaporator Support	X	X
23	137-685	Bottom Evaporator Fill	X	X
24	Control Panel Assembly	See Control Panel Assy. Drawing & Parts List Assy.	X	X
25	113-140	Bottom Mounting Bracket	X	X
26	135X123	Heat Shield	X	X
27	S153-218 ①	Disconnect Access Door	X	X
28	137-259	Fill Plate	X	X
29	113-149-* ①	Top Rain Flashing	X	X
31	S536-498	Cond. Partition Block Off Plate	X	X
32	105-1302	Grommet Retainer	X	X
33	135-329	Air Baffle	X	X
34	105-1393	Close Off Angle	X	X

① Exterior cabinet parts are manufactured with various paint color options. To ensure the proper paint color is received, include the complete model and serial number of the unit for which cabinet parts are being ordered.

# FUNCTIONAL COMPONENTS

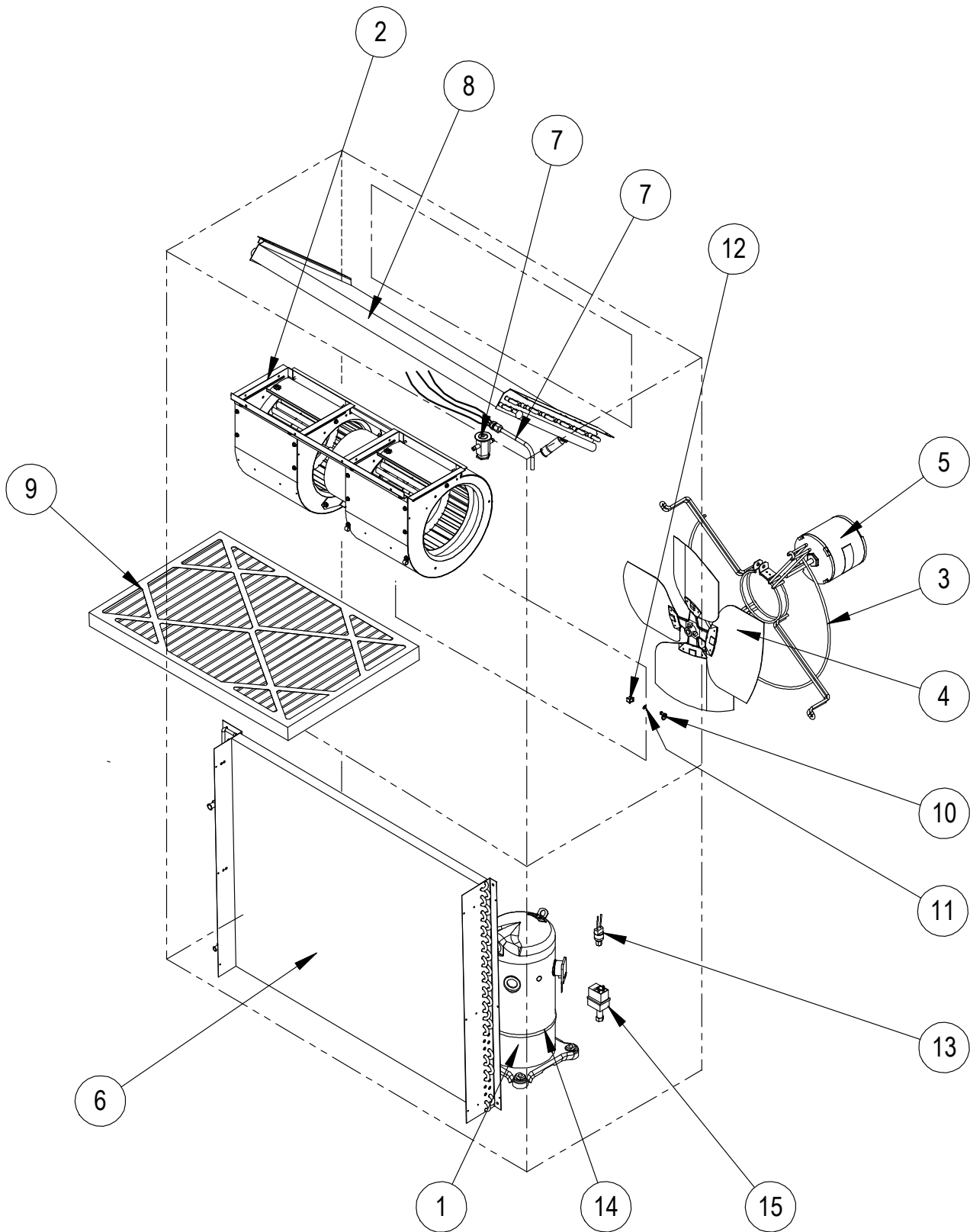

SEXP-855

# FUNCTIONAL COMPONENTS

Dwg No.	Part Number	Description	D25A2PA	D35A2PA	D35A2PB
1	8000-276	Compressor	X		
1	8000-309	Compressor		X	
1	8000-310	Compressor			X
2	S900-352	Blower Assembly	X	X	X
3	8200-001	Fan Motor Mount	X	X	X
4	5151-045	Fan Blade	X	X	X
5	8103-013	Condenser Motor	X	X	X
6	5051-202BX	Condenser Coil	X	X	X
6	5054-202BX	Condenser Coil - Coated	X	X	X
7	800-0456	Distributor Assembly	X	X	X
8	917-0331	Evaporator Coil w/Distributor Assy.	X		
8	917-0332	Evaporator Coil - Coated w/Distributor Assy.	X		
8	917-0274BX	Evaporator Coil w/Distributor Assy.		X	X
8	917-0287BX	Evaporator Coil - Coated w/Distributor Assy.		X	X
9	7004-026	Air Filter 2" Pleated (16x30x2) 8 MERV	X	X	X
9	7004-048	Air Filter 2" Pleated ① (16x30x2) 11 MERV	X	X	X
10	1171-022	1/4" Turn Fastener	X	X	X
11	1171-024	1/4" Turn Retainer	X	X	X
12	1171-023	1/4" Receptacle	X	X	X
13	8406-142	High Pressure Switch (Screw On)	X	X	X
NS	8406-140	Low Pressure Switch (Screw On)	X	X	X
14	8605-019	Crankcase Heater ①	X	X	X
15	8612-027	Low Ambient Control Modulating	X		
15	CMA-28	Low Ambient Control (Screw On) ①		X	X
NS	5201-021	Filter Drier	X	X	X
NS	5451-024	Tubing Isolation Grommet	2	2	2
NS	6031-009	Coremax Valve Core	2	2	2

NS – Not Shown

① – Optional on these models

# CONTROL PANEL - RIGHT HAND

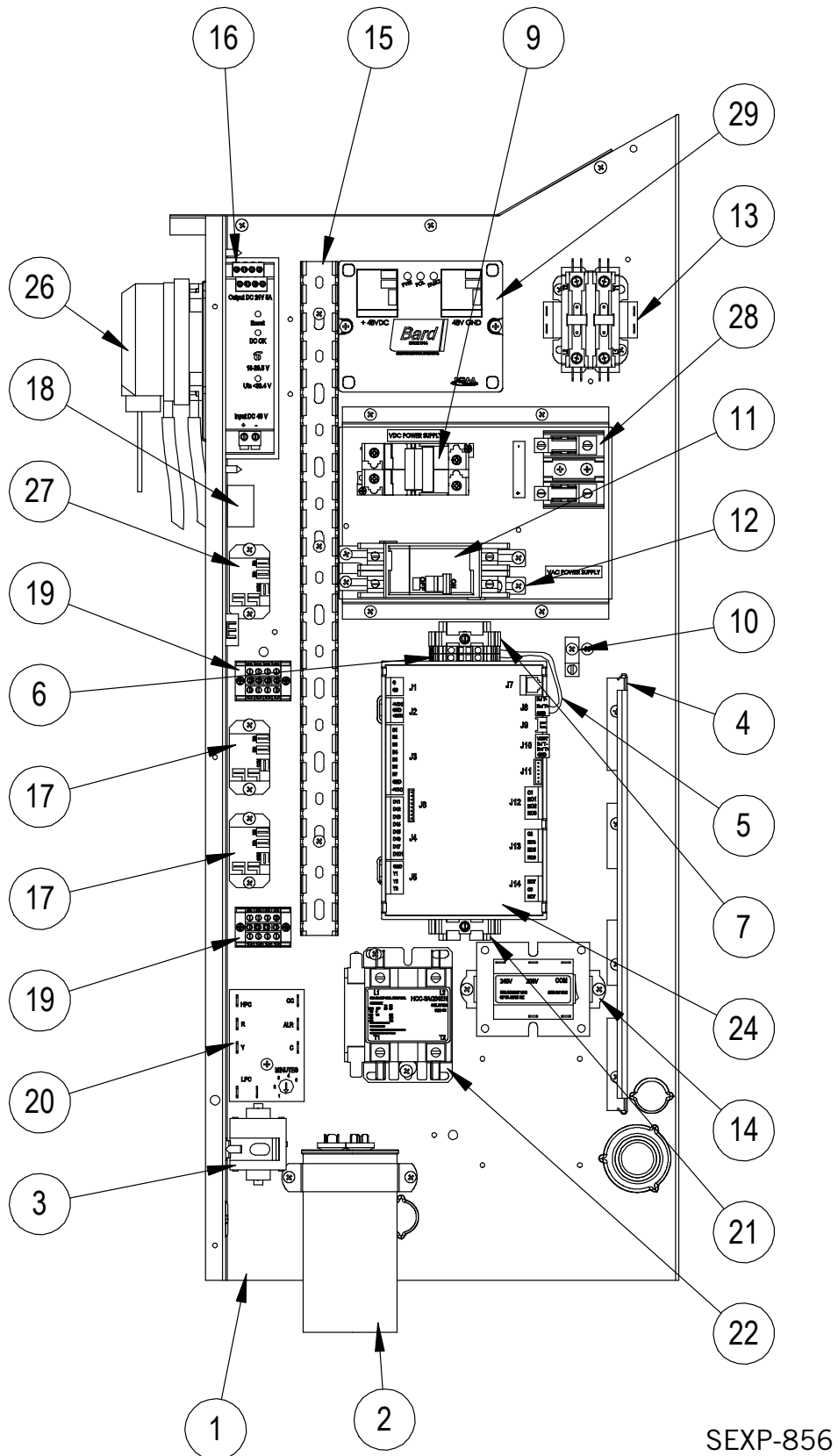

SEXP-856

## CONTROL PANEL - RIGHT HAND

Dwg. No.	Part Number	Description	D25AP2A	D35AP2A	D35AP2B
1	517X357	Control Panel	X	X	X
2	8552-050	Capacitor 40/5 MFD 370V	X		
2	8552-052	Capacitor 45/5 MFD 370V		X	
2	8552-002	Capacitor 70/5 MFD 370V			X
3	8551-004	Motor Starting Device	X	X	X
4	135-122	Wire Shield	X	X	X
5	3020-004	12" 2 Conductor Shielded Cable	X	X	X
6	8611-150	Terminal Block for DIN Rail RS485	X	X	X
7	8611-144	End Clamp for DIN Rail	X	X	X
9	8615-079	Circuit Breaker 20A 125 VDC	X	X	X
10	8611-006	Ground Terminal	X	X	X
11	8615-037	Circuit Breaker 40A 2-Pole	X		
11	8615-039	Circuit Breaker 60A 2-Pole		X	X
11	8615-051	Circuit Breaker 25A 3-Pole			X
12	8615-057	Circuit Breaker Mounting Foot	X	X	X
13	8401-006	Contactor 2-Pole 20 Amp	X	X	
13	8401-002	Contactor 3-Pole 25 Amp			X
14	8407-048	Transformer 208/240-24-75VA	X	X	X
15	8611-140-1800	2-1/4" x 1" Cable Duct 18"	X	X	X
16	8301-050	48VDC to 24VDC Converter 5 Amps	X	X	X
17	8201-130	Compressor and Power Loss SPDT Relays	2	2	2
18	3000-1553	Wire Assembly	X	X	X
19	8607-037	Terminal Block 4 Position	2	2	2
20	8201-088	Compressor Control Module	X	X	X
21	8611-145	35mm DIN Rail 8-1/2"	X	X	X
22	8401-038	Contactor 2-Pole 40 Amp	X	X	
22	8401-027	Contactor 3-Pole 30 Amp			X
24	8301-051-003A	Micro PC - Small	X	X	X
26	910-2016	Filter Switch Assembly	X	X	X
27	8201-151	Blower Motor Start Relay SPDT 24VDC Coil	X	X	X
28	8607-013	Terminal Block	X	X	X
29	8201-156	DC Polarity-Voltage Monitor	X	X	X
NS	3000-1555	Vent Motor Plug Harness	X	X	X
NS	3000-1554	Blade Switch and Return Air Sensor Harness	X	X	X
NS	4206-114	Unit Wiring Diagram	X	X	X
NS	4206-200	Unit Wiring Diagram			X
NS	3000-1224	Compressor Harness	X	X	
NS	3000-1231	Compressor Harness	X	X	

NS – Not Shown

# CONTROL PANEL - LEFT HAND

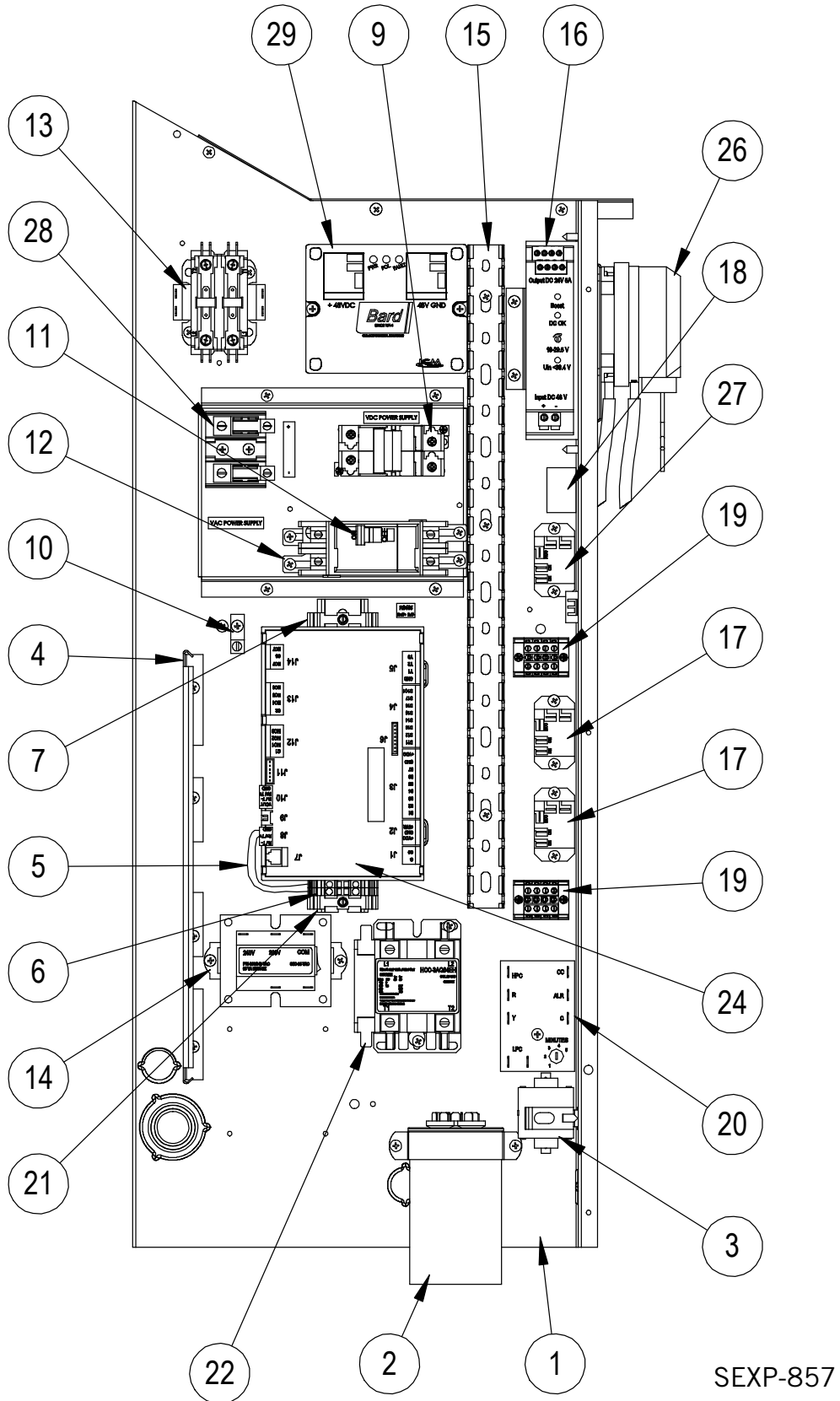

SEXP-857



## CONTROL PANEL - LEFT HAND

Dwg. No.	Part Number	Description	D25LP2A	D35LP2A	D35LP2B
1	517Y357	Control Panel	X	X	X
2	8552-050	Capacitor 40/5 MFD 370V	X		
2	8552-052	Capacitor 45/5 MFD 370V		X	
2	8552-002	Capacitor 70/5 MFD 370V			X
3	8551-004	Motor Starting Device	X	X	X
4	135-122	Wire Shield	X	X	X
5	3020-004	12" 2 Conductor Shielded Cable	X	X	X
6	8611-150	Terminal Block for DIN Rail RS485	X	X	X
7	8611-144	End Clamp for DIN Rail	X	X	X
9	8615-079	Circuit Breaker 20A 125 VDC	X	X	X
10	8611-006	Ground Terminal	X	X	X
11	8615-037	Circuit Breaker 40A 2-Pole	X		
11	8615-039	Circuit Breaker 60A 2-Pole		X	X
11	8615-051	Circuit Breaker 25A 3-Pole			X
12	8615-057	Circuit Breaker Mounting Foot	X	X	X
13	8401-006	Contactor 2-Pole 20 Amp	X	X	
13	8401-002	Contactor 3-Pole 25 Amp			X
14	8407-048	Transformer 208/240-24-75VA	X	X	X
15	8611-140-1800	2-1/4" x 1" Cable Duct 18"	X	X	X
16	8301-050	48VDC to 24VDC Converter 5 Amps	X	X	X
17	8201-130	Compressor and Power Loss SPDT Relays	2	2	2
18	3000-1553	Wire Assembly	X	X	X
19	8607-037	Terminal Block 4 Position	2	2	2
20	8201-088	Compressor Control Module	X	X	X
21	8611-145	35mm DIN Rail 8-1/2"	X	X	X
22	8401-038	Contactor 2-Pole 40 Amp	X	X	
22	8401-027	Contactor 3-Pole 30 Amp			X
24	8301-051-003A	Micro PC - Small	X	X	X
26	910-2016	Filter Switch Assembly	X	X	X
27	8201-151	Blower Motor Start Relay SPDT 24VDC Coil	X	X	X
28	8607-013	Terminal Block	X	X	X
29	8201-156	DC Polarity-Voltage Monitor	X	X	X
NS	3000-1555	Vent Motor Plug Harness	X	X	X
NS	3000-1554	Blade Switch and Return Air Sensor Harness	X	X	X
NS	4206-114	Unit Wiring Diagram	X	X	X
NS	4206-200	Unit Wiring Diagram			X
NS	3000-1224	Compressor Harness	X	X	
NS	3000-1231	Compressor Harness	X	X	

NS – Not Shown

# BLOWER ASSEMBLY

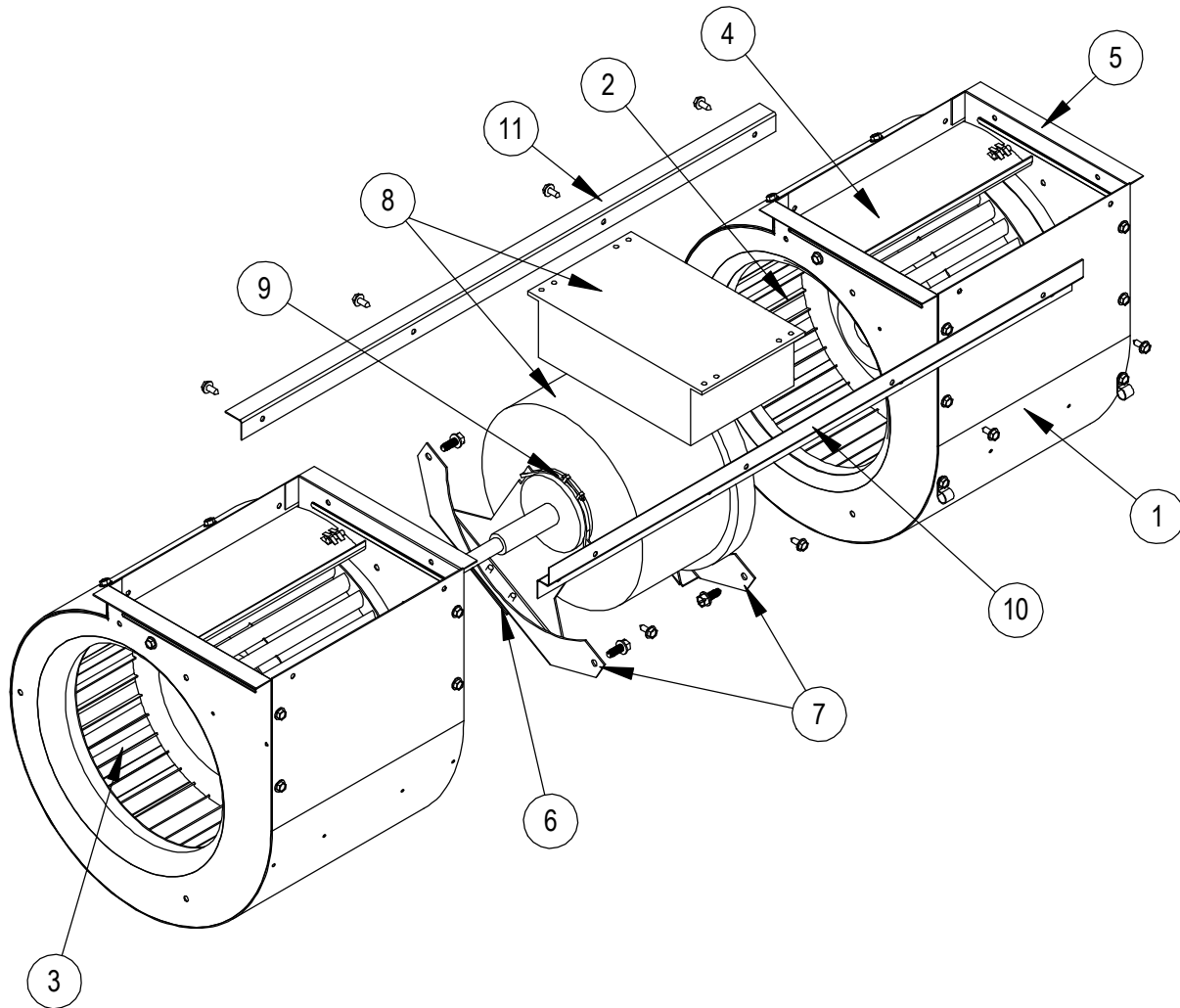

SEXP-858

Dwg. No.	Part Number	Description	S900-352
1	151-111	Blower Housing	2
2	5152-090	Blower Wheel	X
3	5152-091	Blower Wheel	X
4	144-174	Diffuser	2
5	105-880	Blower Angle	4
6	129-026	Cradle Support	1
7	129-025	Cradle Motor Mount	2
8	8107-021	3/4 HP Motor	X
8	8107-025	Motor Controller	X
9	8200-018	Motor Mount Latch	2
10	103-527	Hold In Offset	X
11	104-1406	Rear Blower Angle	X

# DC FREECOOLING

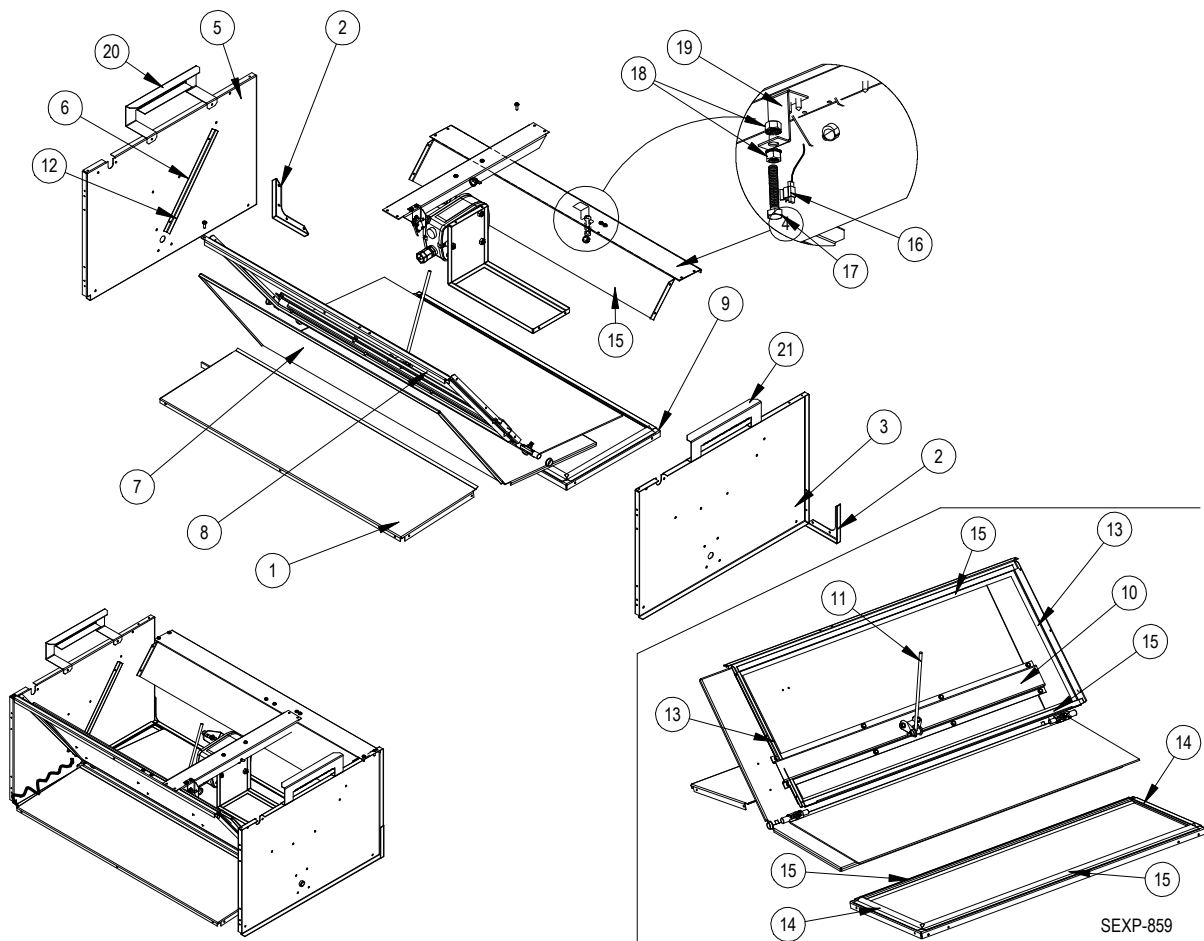

Dwg. No.	Part Number	Description
1	137-738	Lower Front Partition
2	113-526	Corner Bracket
3	S101X979	Right Side
4	S137-865	Upper Rear Partition
5	S101Y978	Left Side
6	S105-1344	Blade Seal Angle
7	S139-324	Blade
8	S137-867	Upper Front Partition
9	S137-740	Lower Rear Partition
10	141-430	Blade Support
11	8602-044	1/4 x 9" Rod
12	1921-067-0800	29-9/16" Damper Blade Seal
13	1921-067-1004	13" Damper Blade Seal
14	1921-067-0802	10-11/16" Damper Blade Seal
15	1921-067-2504	29-3/8" Damper Blade Seal
16	8408-044	Defrost Sensor 10K Ohm Curve J w/ 5/16" Clip
17	1012-052	Hex Head Bolt 5/16 - 18x1-3/4" 0.0005 Zinc w/ Yellow Chromate
18	1012-210	5/16" Nut 0.0005 Zinc w/ Yellow Chromate
19	113-631	Sensor Bracket
20	113-542	Filter Bracket
21	113-543	Filter Bracket

# DC FREECOOLING AIR HOOD

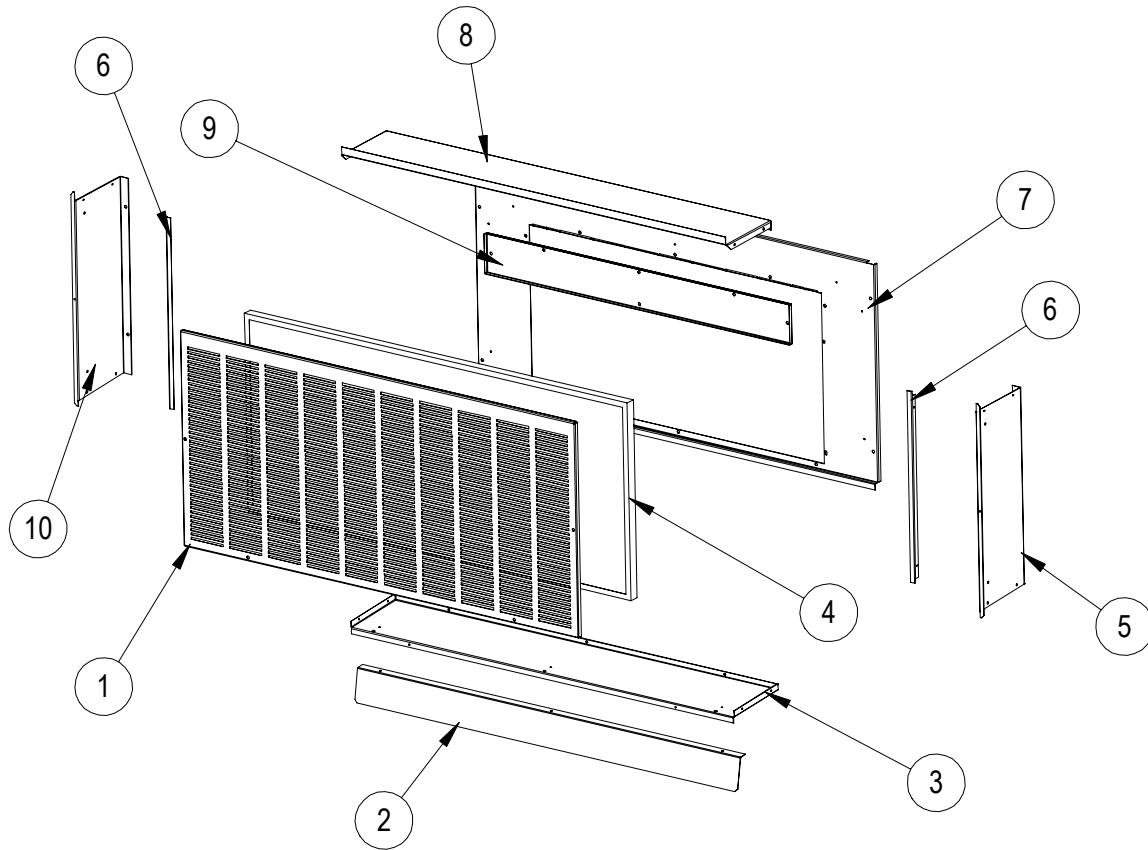

SEXP-752A

1	115-284-* ①	Hooded Front Door
2	113-538-* ①	Bottom Divider Bracket
3	S127-495-* ①	Hood Bottom
4	7003-066	Mist Filter 40-1/4" x 17-7/8" x 7/8"
5	S101-984-* ①	Right Side
6	105-1346	Side Filter Angle
7	553-600-* ①	Hood Mounting Door
8	S107-346-* ①	Hood Top
9	553-661	Filter Door
10	S101-873-* ①	Left Side
	S920-0375	Complete Hood Assembly - Beige
	S920-0376	Complete Hood Assembly - White
	S920-0377	Complete Hood Assembly - Buckeye Gray

① Exterior cabinet parts are manufactured with various paint color options. To ensure the proper paint color is received, reference the following codes:

Beige	-X	Buckeye Gray	-4
White	-1		

# DC FREECOOLING DAMPER MOTOR

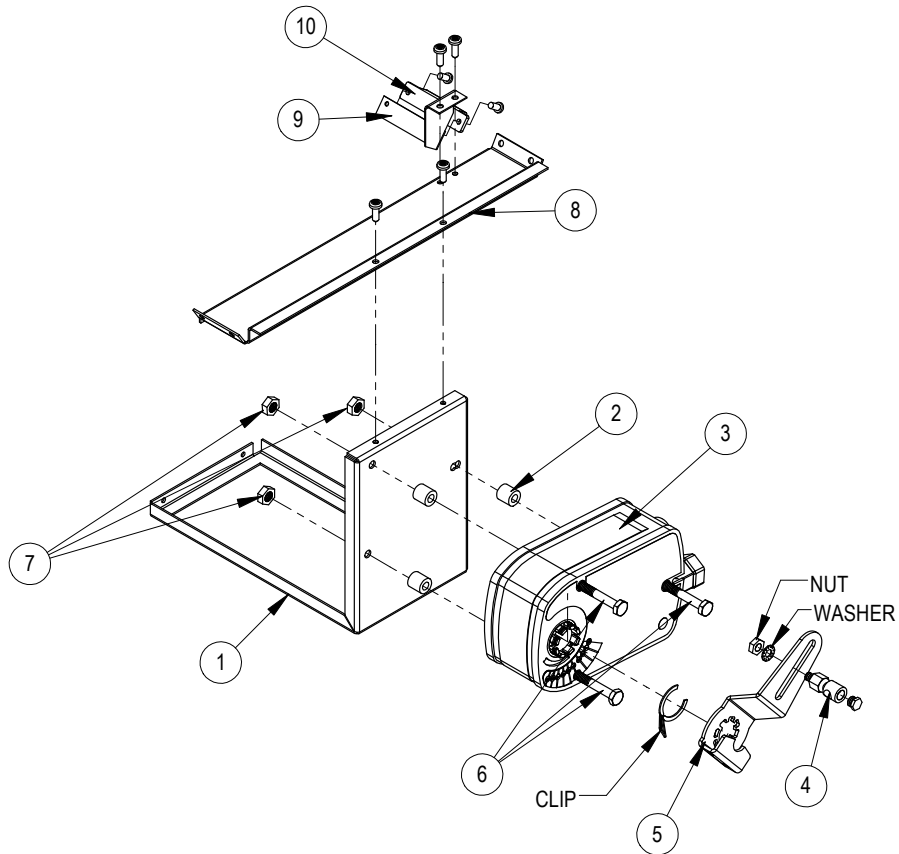

SEXP-754 A

1	141-466	Actuator Support Plate
2	5451-029	Nylon Sleeve 0.257" ID x 0.5" Long
3	8602-075	Direct Coupled Actuator
4	8602-008	Ball Joint
5	8602-078	Belimo Actuator Crank Arm 1/2"
6	1012-174	1/4" - 20x3 - 1/4 Hex Cap Screws
7	1012-201	1/4-20 Steel Keps Hex Nut Zinc
8	141-464	Actuator Support Bar
9	113-626	Blade Switch Bracket
10	8406-138	Lever Switch SPDT Sealed Pilot Duty
11	1012-178	4-40 x 5/8" Phillips Pan Head Machine Screw, Zinc Plated
12	1012-231	4-40 Steel Keps Hex Nut Zinc

# BARD-LINK™ PLC LEAD/LAG CONTROLLER

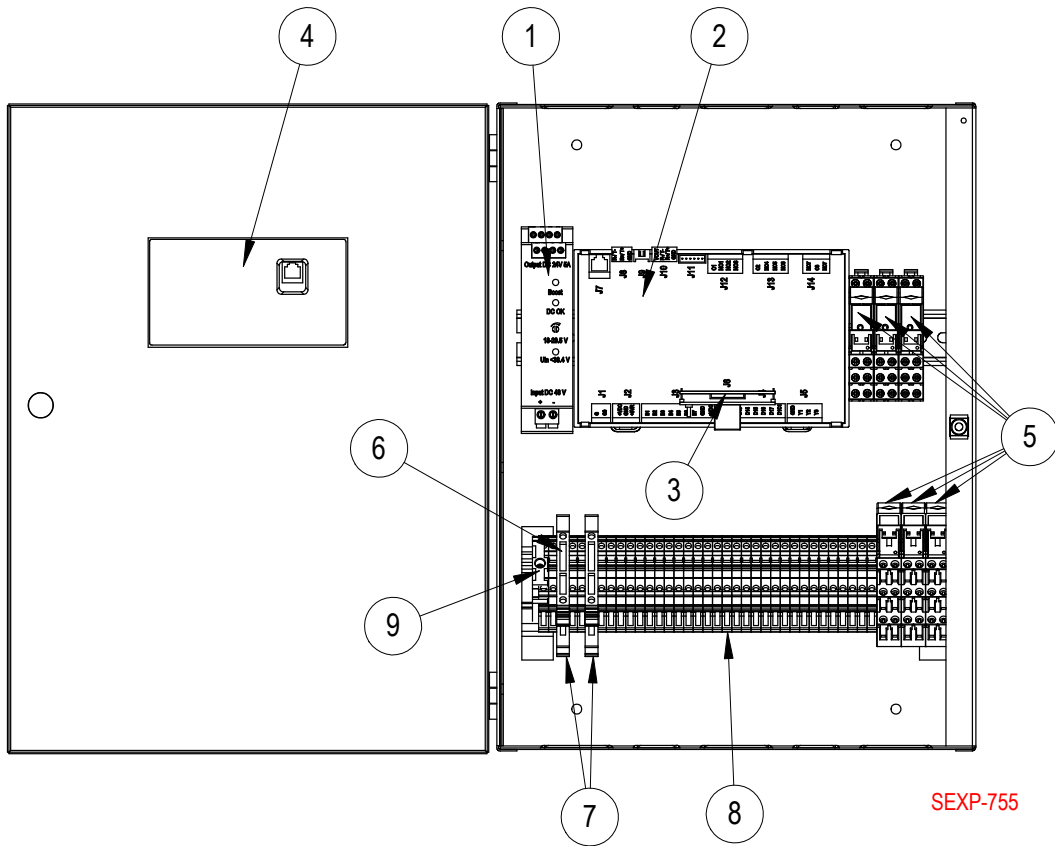

Dwg. No.	Part Number	Description	LC1000	LC1500	LC2000
1	8301-050	48VDC to 24VDC Converter 5 Amps	X	X	
2	8301-051-001B	Micro PC – Small, programmed for LC1000/LC1500	X	X	
2	8301-051-005B	Micro PC – Small, programmed for LC2000			X
3	8301-052	Web Card (Ethernet 1BaseT card for SNMP, FTP, HTTP, DHCP, DNS, BACnet over IP and BACnet Ethernet)	X	X	X
4	8301-053	Panel mounting display flush, pGDEvolution 132x64, black buttons with cable	X	X	X
5	8201-154	24VDC Isolation Relay, DPDT	6	6	6
6	8614-055	2.5 Amp Fuse	2	2	2
7	8607-039	Fused Terminal Block	2	2	2
8	8607-038	Terminal Block	32	32	32
9	8611-144	End Clamp (for din rail)	2	2	2
NS	8301-055	EMI Ferrite Filter	2	2	2
NS	8301-058	Remote Temperature Sensor*	X	X	X
NS	8403-079	Remote Temperature/Humidity Sensor	X	X	X
NS	8611-181	Umbilical Cord for Punch-Down Alarm Block		X	
NS	8607-040	66 Punch-Down Alarm Block		X	
NS	8301-060	Smoke Detector		X	
NS	8301-061	Hydrogen Detector*		X	
NS	8301-059	TEC-EYE™ (Service Tool), 5 ft. telephone cable	X	X	X

NS – Not Shown

\* Optional