REPLACEMENT PARTS MANUAL

WALL MOUNTED PACKAGED AIR CONDITIONER

Models:

W30AB-A W36AB-A W30ABDA W36ABDA
W30AB-B W36AB-B W30ABDB W36ABDB
W30AB-C W36AB-C W30ABDC W36ABDC
W30AB-D W36AB-D
W30AB-F W36AB-E
W36AB-F

Contents

Description	Page	Description	Page
Cabinet Components – Standard & Dehum.		Blower Assembly	
♦ Exploded View	2	♦ Exploded View	12
♦ Usage List	3	♦ Usage List	12
Functional Components		General Notes	
♦ Exploded View	4	➤ Revised and/or additional pages may be issued from time to time.	
♦ Usage List – Standard	5	➤ A complete and current manual consists of pages shown in the following contents section.	
♦ Usage List – Dehum.	6	Important	
EEV Controller Assembly		➤ Contact the installing and/or local Bard distributor for all parts requirements. Make sure you have the complete model and serial number available from the unit rating plates.	
♦ Exploded View	7		
♦ Usage List	7		
Control Panel – Standard			
♦ Layout View	8		
♦ Usage List	9		
Control Panel – Dehum.			
♦ Layout View	10		
♦ Usage List	11		



Bard Manufacturing Company, Inc.
Bryan, Ohio 43506
www.bardhvac.com

Manual: 2110-1449B
Supersedes: 2110-1449A
Date: 10-23-19

CABINET COMPONENTS

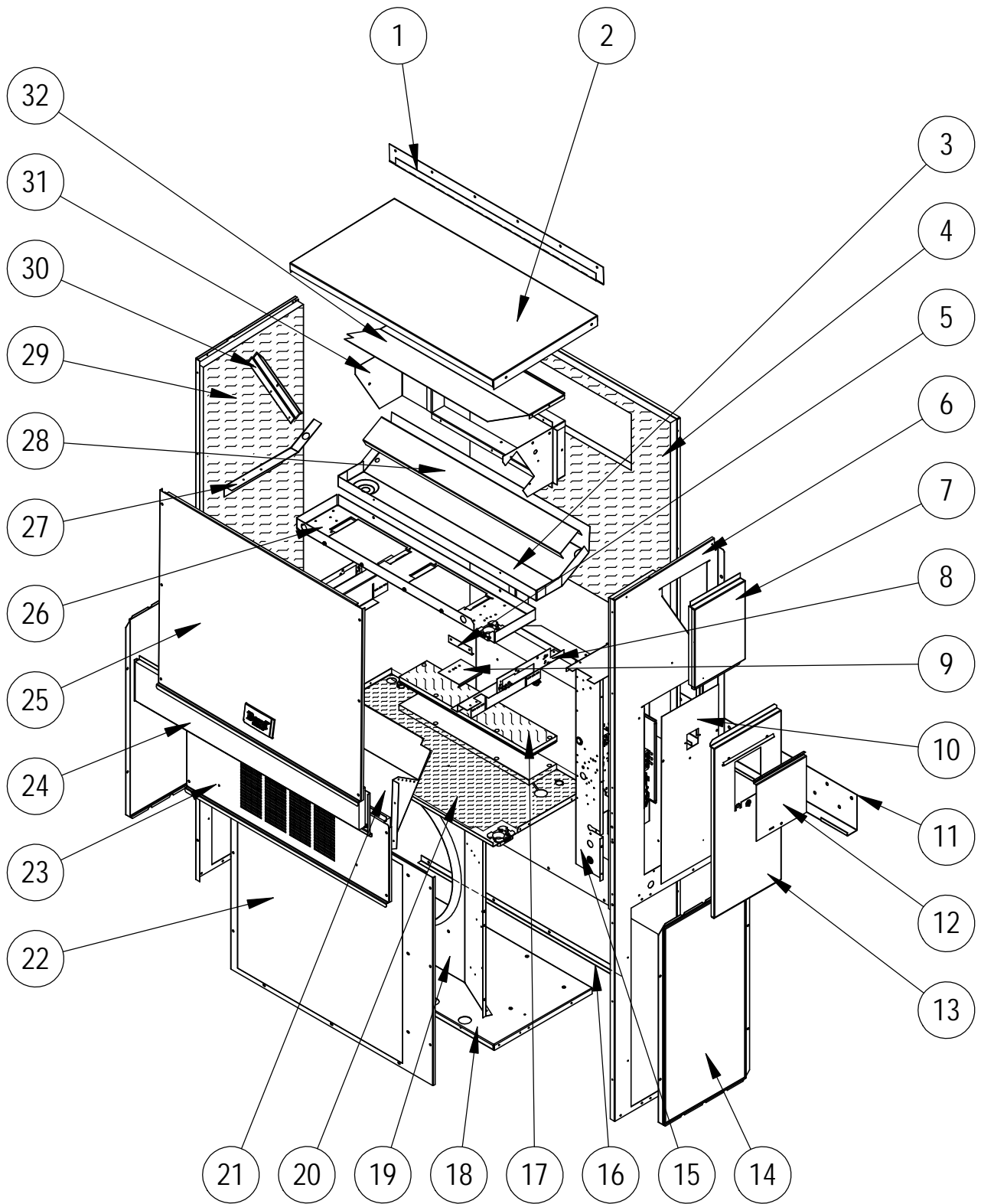

SEXP-907

CABINET COMPONENTS – STANDARD & DEHUMIDIFICATION

Dwg No.	Part Number	Description	W30AB-A, B, D	W30AB-C, F	W30ABDA, B	W30ABDC	W36AB-A, B, D, E	W36AB-C, F	W36ABDA, B	W36ABDC
1	113-149-* ①	Top Rain Flashing	X	X	X	X	X	X	X	X
1	113-360 ②	Top Rain Flashing	X	X	X	X	X	X	X	X
1	113-149-4 ③	Top Rain Flashing	X	X	X	X	X	X	X	X
2	S507-308-* ①	Top	X	X	X	X	X	X	X	X
2	S507-319 ②	Top	X	X	X	X	X	X	X	X
2	S507-320 ③	Top	X	X	X	X	X	X	X	X
3	S123-127	Drain Pan	X	X	X	X	X	X	X	X
3	S123-141 ②③	Drain Pan	X	X	X	X	X	X	X	X
4	S508-343	Back	X	X	X	X	X	X	X	X
4	S508-388 ②	Back	X	X	X	X	X	X	X	X
4	S508-345 ③	Back	X	X	X	X	X	X	X	X
5	105-1302	Grommet Retainer	X	X	X	X	X	X	X	X
6	S501-933-* ①	Right Side	X	X	X	X	X	X	X	X
6	S501-994 ②	Right Side	X	X	X	X	X	X	X	X
6	S501-937 ③	Right Side	X	X	X	X	X	X	X	X
7	S543-175-* ①	Right Side Cover Plate (Outer)	X	X	X	X	X	X	X	X
7	S543-185 ②	Right Side Cover Plate (Outer)	X	X	X	X	X	X	X	X
7	S543-184 ③	Right Side Cover Plate (Outer)	X	X	X	X	X	X	X	X
8	113X480	Filter Bracket	2	2	2	2	2	2	2	2
9	137-259	Fill Plate	X	X	X	X	X	X	X	X
10	S132-104	Control Panel Cover (Inner)	X		X		X		X	
10	S132-172	Control Panel Cover (Inner)		X		X		X		X
11	113-140	Bottom Mounting Bracket	X	X	X	X	X	X	X	X
12	S153-218 ①	Disconnect Access Door	X	X	X	X	X	X	X	X
12	S153-405 ②	Disconnect Access Door	X	X	X	X	X	X	X	X
12	S153-387 ③	Disconnect Access Door	X	X	X	X	X	X	X	X
13	S533-228 ①	Control Panel Cover (Outer)	X	X	X	X	X	X	X	X
13	S533-235 ②	Control Panel Cover (Outer)	X	X	X	X	X	X	X	X
13	S533-236 ③	Control Panel Cover (Outer)	X	X	X	X	X	X	X	X
14	118-124-* ①	Side Grille	2	2	2	2	2	2	2	2
14	118-140 ②	Side Grille	2	2	2	2	2	2	2	2
14	118-139 ③	Side Grille	2	2	2	2	2	2	2	2
15	Control Panel Assembly	See Control Panel Assy. Drawing & Parts List Assy.	X	X	X	X	X	X	X	X
16	105-1393	Close Off Angle	X	X	X	X	X	X	X	X
17	S536-498	Cond. Partition Block Off Plate	X	X	X	X	X	X	X	X
17	S536-877 ②	Cond. Partition Block Off Plate	X	X	X	X	X	X	X	X
18	127-471	Lower Base	X	X	X	X	X	X	X	X
18	S127-528 ②	Lower Base	X	X	X	X	X	X	X	X
19	125-081	Fan Shroud	X	X	X	X	X	X	X	X
19	125-083 ②	Fan Shroud	X	X	X	X	X	X	X	X
20	S521X527	Condenser Partition	X	X	X	X	X	X	X	X
20	S521-552 ②	Condenser Partition	X	X	X	X	X	X	X	X
21	FAD-NE3	Fresh Air Damper Assembly	X	X	X	X	X	X	X	X
22	118-103-* ①	Condenser Grille	X	X	X	X	X	X	X	X
22	118-108 ②	Condenser Grille	X	X	X	X	X	X	X	X
22	118-113 ③	Condenser Grille	X	X	X	X	X	X	X	X
23	S553-523-* ①	Vent Option Door	X	X	X	X	X	X	X	X
23	S553-540-* ①	Vent Option Door with ERV	X	X	X	X	X	X	X	X
23	S553-549 ②	Vent Option Door	X	X	X	X	X	X	X	X
23	S553-557 ②	Vent Option Door with ERV	X	X	X	X	X	X	X	X
23	S553-550 ③	Vent Option Door	X	X	X	X	X	X	X	X
23	S553-558 ③	Vent Option Door with ERV	X	X	X	X	X	X	X	X
24	S553-524-* ①	Filter Door	X	X	X	X	X	X	X	X
24	S553-553 ②	Filter Door	X	X	X	X	X	X	X	X
24	S553-554 ③	Filter Door	X	X	X	X	X	X	X	X
25	S514-241-* ①	Upper Front	X	X	X	X	X	X	X	X
25	S514-238 ②	Upper Front	X	X	X	X	X	X	X	X
25	S514-239 ③	Upper Front	X	X	X	X	X	X	X	X
26	121X467	Blower Partition	X	X	X	X	X	X	X	X
27	105X850	Side Support	X	X	X	X	X	X	X	X
28	137-685	Bottom Evaporator Fill	X	X			X	X		
28	137-722	Bottom Evaporator Fill			X	X			X	X
29	S501-934-* ①	Left Side	X	X	X	X	X	X	X	X
29	S501-995 ②	Left Side	X	X	X	X	X	X	X	X
29	S501-940 ③	Left Side	X	X	X	X	X	X	X	X
30	147-044	Evaporator Support	X	X	X	X	X	X	X	X
31	S111X247	Outlet Air Frame Assembly	X	X	X	X	X	X	X	X
32	135X123	Heat Shield	X	X	X	X	X	X	X	X
NS	135-329	Air Baffle	X	X			X	X		

- ① Exterior cabinet parts are manufactured with various paint color options. To ensure the proper paint color is received, include the complete model and serial number of the unit for which cabinet parts are being ordered.
- ② Exterior cabinet parts are manufactured from stainless steel Code "S"
- ③ Exterior cabinet parts are manufactured from aluminum Code "A"

FUNCTIONAL COMPONENTS

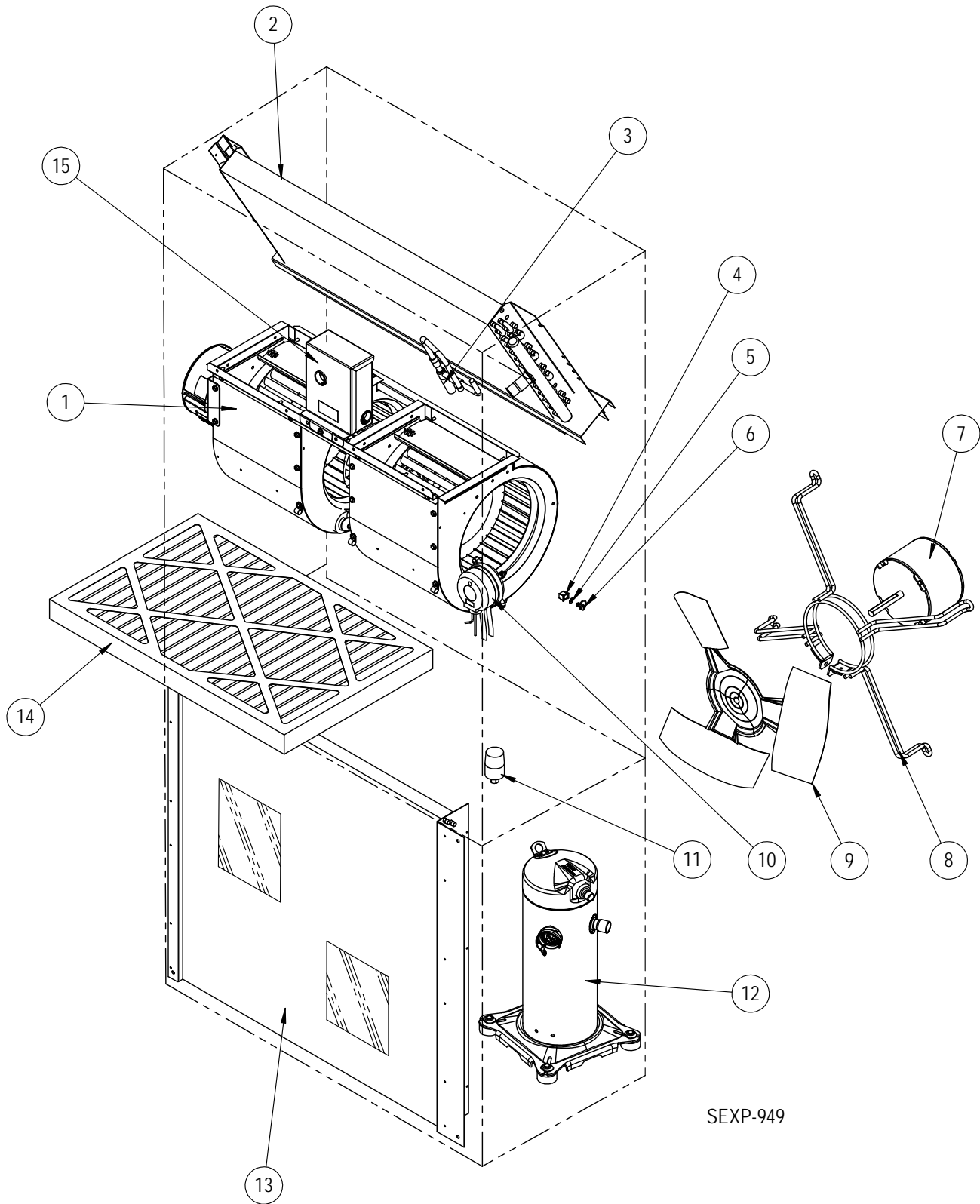

FUNCTIONAL COMPONENTS - STANDARD

Dwg No.	Part Number	Description	W30AB-A	W30AB-B	W30AB-C	W30AB-D	W30AB-F	W36AB-A	W36AB-B	W36AB-C	W36AB-D	W36AB-E	W36AB-F
1	S900-360-001	Blower Assembly	X	X		X	X						
1	S900-361-001	Blower Assembly			X								
1	900-360-002	Blower Assembly						X	X		X	X	X
1	900-361-002	Blower Assembly								X			
2	917-0355BX	Evaporator Coil w/Distributor Assy.	X	X	X	X	X						
2	917-0356BX	Evaporator Coil - Coated w/Distributor Assy.	X	X	X	X	X						
2	917-0357BX	Evaporator Coil w/Distributor Assy.						X	X	X	X	X	X
2	917-0358BX	Evaporator Coil - Coated w/Distributor Assy.						X	X	X	X	X	X
3	800-0456	Distributor Assembly						X	X	X	X	X	X
3	800-0479	Distributor Assembly	X	X	X	X	X						
4	1171-023	1/4" Receptacle	X	X	X	X	X	X	X	X	X	X	X
5	1171-024	1/4" Turn Retainer	X	X	X	X	X	X	X	X	X	X	X
6	1171-022	1/4" Turn Fastener	X	X	X	X	X	X	X	X	X	X	X
7	8103-029	Condenser Motor	X	X		X	X	X			X	X	X
7	8103-030	Condenser Motor			X					X			
8	8200-001	Fan Motor Mount	X	X	X	X	X	X	X	X	X	X	X
8	8200-050 ①	Stainless Steel Fan Motor Mount	X	X	X	X	X	X	X	X	X	X	X
9	5151-045	Fan Blade	X	X	X	X	X	X	X	X	X	X	X
9	5151C045 ①	Coated Fan Blade	X	X	X	X	X	X	X	X	X	X	X
10	CMC-31	Dirty Filter Switch Kit	X	X	X	X	X	X	X	X	X	X	X
11	CMA-39	Low Ambient Control (Screw On) ②	X	X	X	X	X	X	X	X	X	X	X
12	8000-277	Compressor	X										
12	8000-365	Compressor		X									
12	8000-366	Compressor			X		X						
12	8000-438	Compressor				X							
12	8000-278	Compressor					X						
12	8000-283	Compressor						X				X	
12	8000-342	Compressor							X				X
12	8000-439	Compressor								X			
13	5051-203BX	Condenser Coil	X	X	X	X	X						
13	5054-203BX	Condenser Coil - Coated	X	X	X	X	X						
13	5051-202BX	Condenser Coil						X	X	X	X	X	X
13	5054-202BX	Condenser Coil - Coated						X	X	X	X	X	X
14	7004-019	Air Filter 1" Throw-Away (16x30x1)	X	X	X	X	X	X	X	X	X	X	X
14	7003-031	Air Filter 1" Washable ② (16x30x1)	X	X	X	X	X	X	X	X	X	X	X
14	7004-026	Air Filter 2" Pleated ② (16x30x2)	X	X	X	X	X	X	X	X	X	X	X
14	7004-048	Air Filter 2" Pleated MERV 11 ② (16x30x2)	X	X	X	X	X	X	X	X	X	X	X
14	7004-062	Air Filter 2" Pleated MERV 13 ② (16x30x2)	X	X	X	X	X	X	X	X	X	X	X
NS	8406-142	High Pressure Switch (Screw On)	X	X	X	X	X	X	X	X	X	X	X
NS	8406-140	Low Pressure Switch (Screw On)	X	X	X	X	X	X	X	X	X	X	X
NS	5201-021	Filter Drier	X	X	X	X	X	X	X	X	X	X	X
NS	5451-024	Tubing Isolation Grommet	2	2	2	2	2	2	2	2	2	2	2
NS	6031-009	Coremax Valve Core	2	2	2	2	2	2	2	2	2	2	2
NS	1171-028	Filter Door Clip	2	2	2	2	2	2	2	2	2	2	2
NS	1171-057	Filter Door Screw	2	2	2	2	2	2	2	2	2	2	2
NS	1171-027	Filter Door Screw Retainer	2	2	2	2	2	2	2	2	2	2	2

NS – Not Shown

① – Used with stainless steel cabinet option

② – Optional on these models

FUNCTIONAL COMPONENTS – DEHUMIDIFICATION

Dwg No.	Part Number	Description	W30ABDA	W30ABDB	W30ABDC	W36ABDA	W36ABDB	W36ABDC
1	S900-360-001	Blower Assembly	X	X				
1	S900-361-001	Blower Assembly			X			
1	900-360-002	Blower Assembly				X	X	
1	900-361-002	Blower Assembly						X
2	917-0364BX	Evaporator Coil w/Distributor Assy.	X	X	X			
2	917-0365BX	Evaporator Coil - Coated w/Distributor Assy.	X	X	X			
2	917-0359BX	Evaporator Coil w/Distributor Assy.				X	X	X
2	917-0360BX	Evaporator Coil - Coated w/Distributor Assy.				X	X	X
3	800-0460	Distributor Assembly	X	X	X	X	X	X
3	5651S245	Electronic Expansion Valve	X	X	X	X	X	X
3	905-0732	Electronic Expansion Valve Assembly	X	X	X	X	X	X
4	1171-023	1/4" Receptacle	X	X	X	X	X	X
5	1171-024	1/4" Turn Retainer	X	X	X	X	X	X
6	1171-022	1/4" Turn Fastener	X	X	X	X	X	X
7	8103-029	Condenser Motor	X	X		X	X	
7	8103-030	Condenser Motor			X			X
8	8200-001	Fan Motor Mount	X	X	X	X	X	X
8	8200-050 ①	Stainless Steel Fan Motor Mount	X	X	X	X	X	X
9	5151-045	Fan Blade	X	X	X	X	X	X
9	5151C045 ①	Coated Fan Blade	X	X	X	X	X	X
10	CMC-31	Dirty Filter Switch Kit	X	X	X	X	X	X
11	CMA-39	Low Ambient Control (Flare) ②	X	X	X	X	X	X
12	8000-277	Compressor	X					
12	8000-365	Compressor		X				
12	8000-366	Compressor			X			
12	8000-278	Compressor				X		
12	8000-283	Compressor					X	
12	8000-342	Compressor						X
13	5051-203BX	Condenser Coil	X	X	X			
13	5054-203BX	Condenser Coil - Coated	X	X	X			
13	5051-202BX	Condenser Coil				X	X	X
13	5054-202BX	Condenser Coil - Coated				X	X	X
14	7004-019	Air Filter 1" Throw-Away (16x30x1)						
14	7003-031	Air Filter 1" Washable ② (16x30x1)	X	X	X	X	X	X
14	7004-026	Air Filter 2" Pleated ② (16x30x2)	X	X	X	X	X	X
14	7004-048	Air Filter 2" Pleated MERV 11 ② (16x30x2)	X	X	X	X	X	X
14	7004-062	Air Filter 2" Pleated MERV 13 ② (16x30x2)						
15	S910-2050-001	EEV Controller Assembly (see page 7 for breakdown)	X	X	X	X	X	X
NS	8406-142	High Pressure Switch (Flare)	X	X	X	X	X	X
NS	8406-140	Low Pressure Switch (Flare)	X	X	X	X	X	X
NS	8406-158	Low Pressure Transducer	X	X	X	X	X	X
NS	5201-021	Filter Drier	X	X	X	X	X	X
NS	5650-051	Dehumidification Valve	X	X	X	X	X	X
NS	5651-219	Check Valve	X	X	X	X	X	X
NS	5451-024	Tubing Isolation Grommet	2	2	2	2	2	2
NS	6031-009	Coremax Valve Core	2	2	2	2	2	2
NS	1171-028	Filter Door Clip	2	2	2	2	2	2
NS	1171-057	Filter Door Screw	2	2	2	2	2	2
NS	1171-027	Filter Door Screw Retainer	2	2	2	2	2	2

NS – Not Shown

① – Used with stainless steel cabinet option

② – Optional on these models

EEV CONTROLLER ASSEMBLY

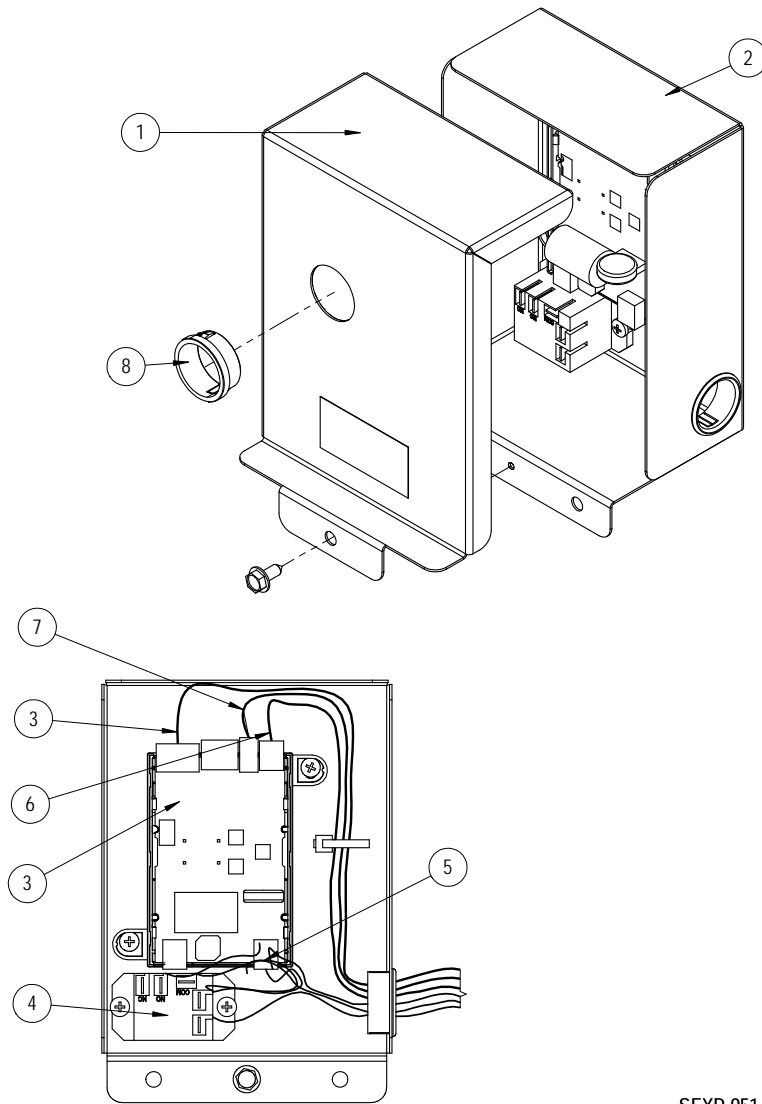

SEXP-951

S910-2050-001

Dwg No.	Part Number	Description	
1	143-219	EEV Control Box Cover	X
2	127-572	EEV Control Box	X
3	S8301-079-0001	EEV Control Module & Stator Cable	X
3	5651-246	EEV Stator Cable Only	X
4	8201-130	Control Relay	X
5	3000-1602	Main Wire Assembly	X
6	3000-1611	Transducer Wire Assembly – Connects to EEV Board	X
6	3000-1603	Transducer Wire Assembly – Connects to Transducer	X
7	8408-056	EEV Thermistor	X
8	8611-075	Clear Snap Plug	X

CONTROL PANEL

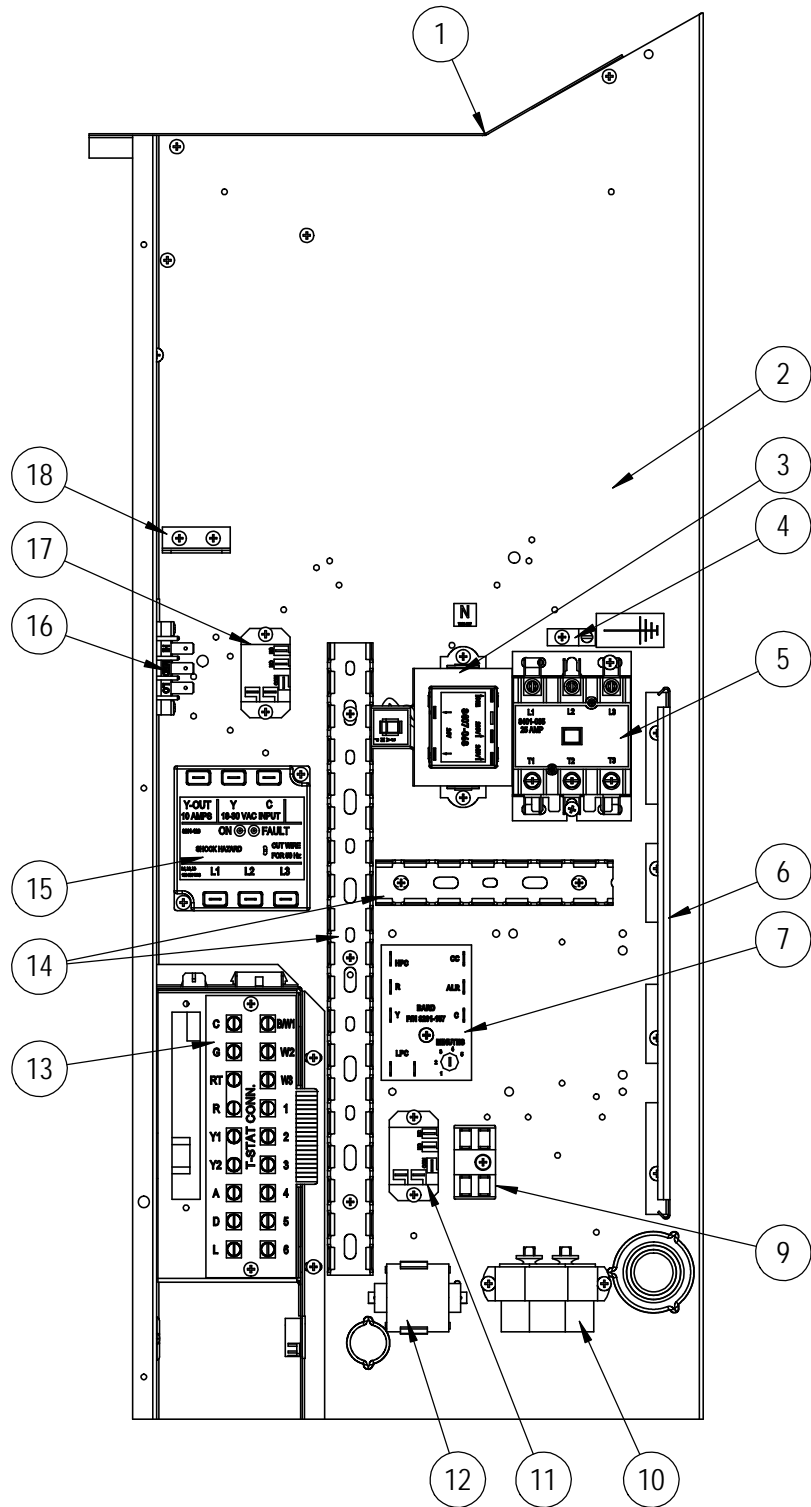

SEXP-908

CONTROL PANEL – STANDARD

Dwg No.	Part Number	Description	W30AB-A	W30AB-B	W30AB-C	W30AB-D	W30AB-F	W36AB-A	W36AB-B	W36AB-C	W36AB-D	W36AB-E	W36AB-F
1	117X137	Control Panel Top	X	X	X	X	X	X	X	X	X	X	X
2	117X407	Control Panel	X	X	X	X	X	X	X	X	X	X	X
3	8407-068	Transformer	X	X		X	X	X			X	X	X
3	8407-069	Transformer			X					X			
4	8611-006	Ground Terminal	X	X	X	X	X	X	X	X	X	X	X
5	8401-033	Compressor Contactor	X			X		X			X		
5	8401-035	Compressor Contactor		X	X		X		X	X		X	X
6	135-122	Wire Shield	X	X	X	X	X	X	X	X	X	X	X
7	8201-164	Compressor Control Module	X	X	X	X	X	X	X	X	X	X	X
9	8607-017	Terminal Block (Optional)	X	X	X	X	X	X	X	X	X	X	X
10	8552-052	Compressor Capacitor	X					X					
10	8552-002	Outdoor Motor Capacitor		X	X		X		X	X		X	X
10	8552-062	Compressor Capacitor				X					X		
11	8201-130	Alarm Relay (Optional)	X	X	X	X	X	X	X	X	X	X	X
12	8551-004	Start Device (PTCR) (Optional)	X			X		X			X		
13	8607-063	Low Voltage Terminal Strip	X	X	X	X	X	X	X	X	X	X	X
14	8611-140-1400	Cable Duct – 14" Piece	X	X	X	X	X	X	X	X	X	X	X
14	8611-140-0500	Cable Duct – 5" Piece	X	X	X	X	X	X	X	X	X	X	X
15	8201-126	Phase Monitor		X	X		X		X	X		X	X
16	8607-042	Blower Speed Terminal	X	X	X	X	X	X	X	X	X	X	X
17	8201-130	Blower Control Relay	X	X	X	X	X	X	X	X	X	X	X
18	141-188	Plug Support Bracket	X	X	X	X	X	X	X	X	X	X	X
NS	8615-038	Circuit Breaker 35A 2 Pole (Opt.) ①	X					X			X		
NS	8615-054	Circuit Breaker 20A 3 Pole (Opt.) ①		X									
NS	8615-052	Circuit Breaker 30A 3 Pole (Opt.) ①				X			X			X	
NS	8615-067	Toggle Disconnect (Optional) ①			X		X			X			X
NS	8607-013	Terminal Block 2 Pole					X						X
NS	113-601	Terminal Block Bracket					X						X
NS	4095-196	Wiring Diagram	X			X		X			X		
NS	4095-296	Wiring Diagram		X					X			X	
NS	4095-378	Wiring Diagram			X					X			
NS	4095-640	Wiring Diagram					X						X
NS	3000-1598	Blower Power Plug	X	X	X	X	X	X	X	X	X	X	X
NS	3000-1599	Blower Speed Plug	X	X	X	X	X	X	X	X	X	X	X
NS	3000-1524	Vent Jumper Plug	X	X	X	X	X	X	X	X	X	X	X
NS	3000-1224	Compressor Plug/Harness	X			X		X			X		
NS	3000-1231	Compressor Plug/Harness		X	X		X		X	X		X	X
NS	3003-047	Control Panel Harness	X			X		X			X		
NS	3003-048	Control Panel Harness		X	X			X	X			X	
NS	3003-049	Control Panel Harness					X						X
NS	3000-1608	Low Voltage Terminal Block Harness	X	X	X	X	X	X	X	X	X	X	X
NS	S910-2047	Complete Low Voltage Box Assembly (Sheet Metal, LVTS & Wire Harness)	X	X	X	X	X	X	X	X	X	X	X

NS = Not Shown

① Circuit breakers listed are for units without electric heat, "OZ" models. See heater replacement parts manual for units with electric heat.

CONTROL PANEL – DEHUMIDIFICATION

Dwg No.	Part Number	Description	W30ABDA	W30ABDB	W30ABDC	W36ABDA	W36ABDB	W36ABDC
1	117X137	Control Panel Top	X	X	X	X	X	X
2	117-407	Control Panel	X	X	X	X	X	X
3	8407-068	Transformer	X	X		X	X	
3	8407-069	Transformer			X			X
4	8611-006	Ground Terminal	X	X	X	X	X	X
5	8401-033	Compressor Contactor	X			X		
5	8401-035	Compressor Contactor		X	X		X	X
6	135-122	Wire Shield	X	X	X	X	X	X
7	8201-164	Compressor Control Module	X	X	X	X	X	X
8	8201-113	Dehum. Logic Control	X	X	X	X	X	X
9	8607-017	Terminal Block (Optional)	X	X	X	X	X	X
10	8552-052	Compressor Capacitor	X			X		
10	8552-002	Outdoor Motor Capacitor		X	X		X	X
11	8201-130	Dehumidification Control Relay	X	X	X	X	X	X
12	8551-004	Start Device (PTCR) (Optional)	X			X		
13	8607-063	Low Voltage Terminal Strip	X	X	X	X	X	X
14	8611-140-1400	Cable Duct – 14" Piece	X	X	X	X	X	X
14	8611-140-0500	Cable Duct – 5" Piece	X	X	X	X	X	X
15	8201-126	Phase Monitor		X	X		X	X
16	8607-042	Blower Speed Terminal	X	X	X	X	X	X
17	8201-130	Blower Control Relay	X	X	X	X	X	X
18	141-188	Plug Support Bracket	X	X	X	X	X	X
NS	8615-038	Circuit Breaker 35A 2 Pole (Optional) ①	X			X		
NS	8615-054	Circuit Breaker 20A 3 Pole (Optional) ①		X				
NS	8615-052	Circuit Breaker 30A 3 Pole (Optional) ①					X	
NS	S8615-067	Toggle Disconnect (Optional) ①			X			X
NS	4095-198	Wiring Diagram	X			X		
NS	4095-297	Wiring Diagram		X			X	
NS	4095-379	Wiring Diagram			X			X
NS	3000-1598	Blower Power Plug	X	X	X	X	X	X
NS	3000-1599	Blower Speed Plug	X	X	X	X	X	X
NS	3000-1524	Vent Jumper Plug	X	X	X	X	X	X
NS	3000-1224	Compressor Plug/Harness	X			X		
NS	3000-1231	Compressor Plug/Harness		X	X		X	X
NS	3003-050	Control Panel Harness	X			X		
NS	3003-051	Control Panel Harness		X	X		X	X
NS	3000-1608	Low Voltage Terminal Block Harness	X	X	X	X	X	X
NS	S910-2047	Complete Low Voltage Box Assembly (Sheet Metal, LVTS & Wire Harness)	X	X	X	X	X	X

NS = Not Shown

① Circuit breakers listed are for units without electric heat, "OZ" models. See heater replacement parts manual for units with electric heat.

BLOWER ASSEMBLY

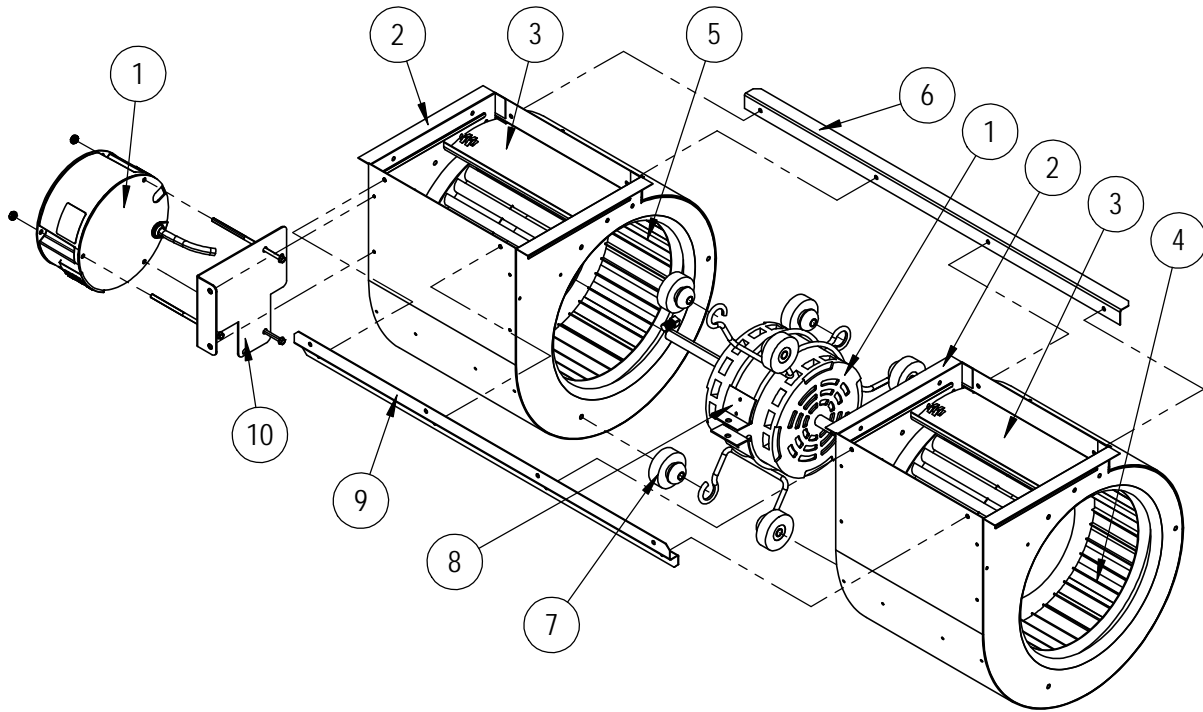

SEXP-909

Dwg No.	Part Number	Description	S900-360-001	S900-360-002	S900-361-001	S900-361-002
1	S8106-068-0150	Blower Motor & Control (230/208V)	X			
1	S8106-068-0152	Blower Motor & Control (230/208V)		X		
1	S8106-069-0151	Blower Motor & Control (460V)			X	
1	S8106-069-0153	Blower Motor & Control (460V)				X
1	C8106-068-0150	Programmed Control Only (230/208V)	0			
1	C8106-068-0152	Programmed Control Only (230/208V)		0		
1	C8106-069-0151	Programmed Control Only (460V)			0	
1	C8106-069-0153	Programmed Control Only (460V)				0
2	151-111	Housing	2	2	2	2
3	144-174	Diffuser	2	2	2	2
4	5152-090	Wheel CW	X	X	X	X
5	5152-091	Wheel CCW	X	X	X	X
6	105-870	Back Brace	X	X	X	X
7	5451-011	Grommets	6	6	6	6
8	8200-031	Motor Mount	X	X	X	X
9	103-401	Front Brace	X	X	X	X
10	113-721	Motor Control Bracket	X	X	X	X