REPLACEMENT PARTS MANUAL

Wall Mounted Packaged Air Conditioner

Models:

W30LB-A W36LB-A
W30LB-B W36LB-B
W30LB-C W36LB-C
W30LB-F W36LBRC
 W36LB-F

General Notes

- Revised and/or additional pages may be issued from time to time.
- A complete and current manual consists of pages shown in the following contents section.

Important

- Contact the installing and/or local Bard distributor for all parts requirements. Make sure to have the complete model and serial number available from the unit rating plates.

Contents

<u>Description</u>	<u>Page</u>
Cabinet Components	
♦ Exploded View	2
♦ Usage List	3
Functional Components	
♦ Exploded View	4
♦ Usage List	5
Control Panel	
♦ Layout View	6
♦ Usage List	7
Blower Assembly	
♦ Exploded View	8
♦ Usage List	8



Bard Manufacturing Company, Inc.
Bryan, Ohio 43506
www.bardhvac.com

Manual: 2110-1450L
Supersedes: 2110-1450K
Date: 1-2-24

CABINET COMPONENTS

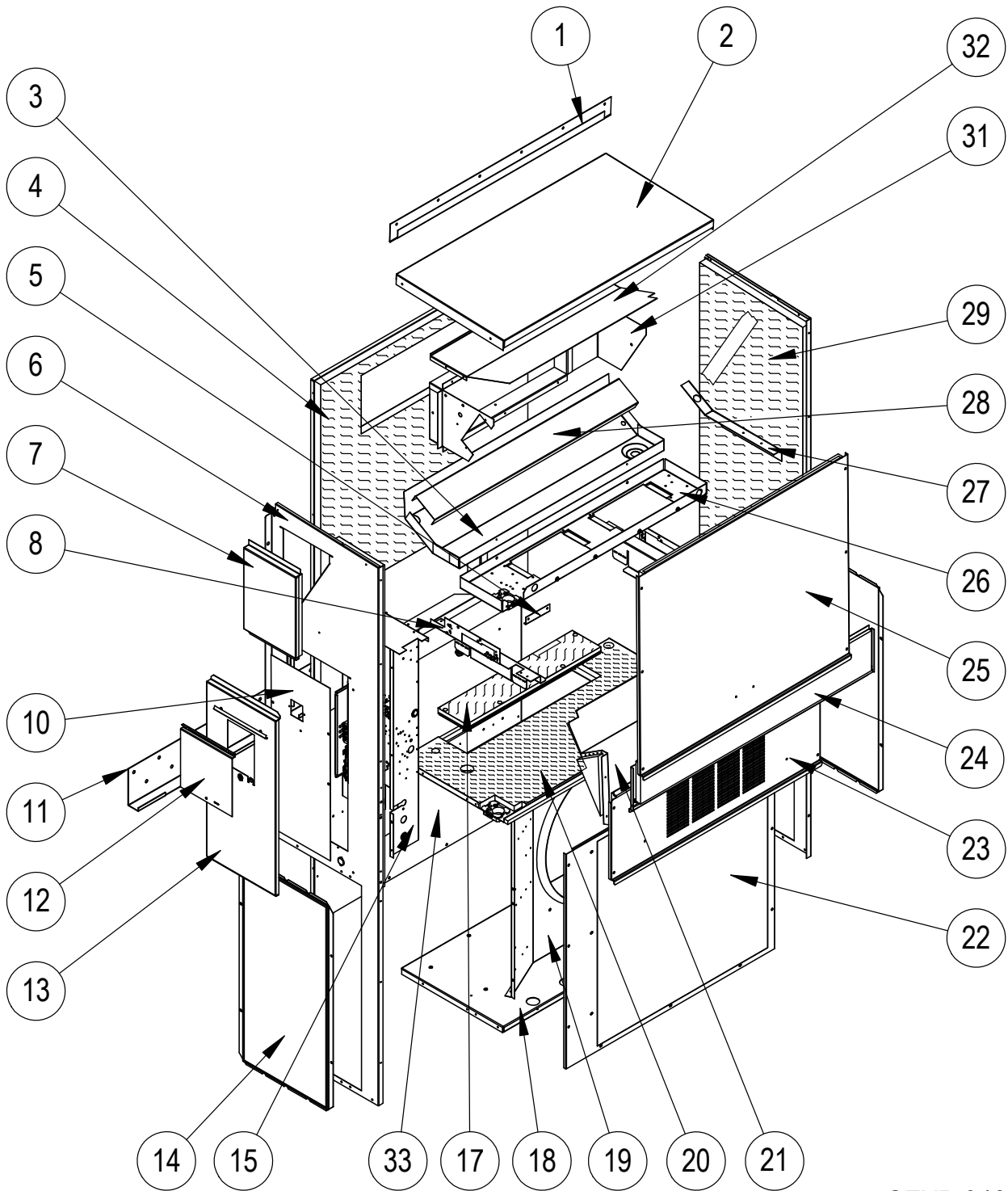

SEXP-946 B

CABINET COMPONENTS

Dwg No.	Part Number	Description	W30LB-A, B	W30LB-C	W30LB-F	W36LB-A, B	W36LB-C, RC	W36LB-F
1	113-149-* ①	Top Rain Flashing	X	X	X	X	X	X
1	113-360 ②	Top Rain Flashing	X	X	X	X	X	X
1	113-149-4 ③	Top Rain Flashing	X	X	X	X	X	X
2	S507-308-* ①	Top	X	X	X	X	X	X
2	S507-319 ②	Top	X	X	X	X	X	X
2	S507-320 ③	Top	X	X	X	X	X	X
3	S123-130	Drain Pan	X	X	X	X	X	X
3	S123-143 ②③	Drain Pan	X	X	X	X	X	X
4	S509-451	Upper Back	X	X	X	X	X	X
4	S509-455 ②	Upper Back	X	X	X	X	X	X
4	S509-453 ③	Upper Back	X	X	X	X	X	X
5	105-1302	Grommet Retainer	X	X	X	X	X	X
6	S501-935-* ①	Right Side	X	X	X	X	X	X
6	S501-998 ②	Right Side	X	X	X	X	X	X
6	S501-943 ③	Right Side	X	X	X	X	X	X
7	S543-175-* ①	Right Side Cover Plate (Outer)	X	X	X	X	X	X
7	S543-185 ②	Right Side Cover Plate (Outer)	X	X	X	X	X	X
7	S543-184 ③	Right Side Cover Plate (Outer)	X	X	X	X	X	X
8	113Y480	Filter Bracket	2	2	2	2	2	2
9	137-259	Fill Plate	X	X	X	X	X	X
10	S132-104	Control Panel Cover (Inner)	X			X		
10	S132-172	Control Panel Cover (Inner)		X	X		X	X
11	113-140	Bottom Mounting Bracket	X	X	X	X	X	X
12	S153-218 ①	Disconnect Access Door	X	X	X	X	X	X
12	S153-405 ②	Disconnect Access Door	X	X	X	X	X	X
12	S153-387 ③	Disconnect Access Door	X	X	X	X	X	X
13	S533-228 ①	Control Panel Cover (Outer)	X	X	X	X	X	X
13	S533-235 ②	Control Panel Cover (Outer)	X	X	X	X	X	X
13	S533-236 ③	Control Panel Cover (Outer)	X	X	X	X	X	X
14	118-124-* ①	Side Grille	2	2	2	2	2	2
14	118-140 ②	Side Grille	2	2	2	2	2	2
14	118-141 ③	Side Grille	2	2	2	2	2	2
15	Control Panel Assembly	See Control Panel Assy. Drawing & Parts List Assy.	X	X	X	X	X	X
17	S536-498	Cond. Partition Block Off Plate	X	X	X	X	X	X
17	S536-877 ②	Cond. Partition Block Off Plate	X	X	X	X	X	X
18	S127-472	Lower Base	X	X	X	X	X	X
18	S127-533 ②	Lower Base	X	X	X	X	X	X
19	125-081	Fan Shroud	X	X	X	X	X	X
19	125-083 ②	Fan Shroud	X	X	X	X	X	X
20	S521Y527	Condenser Partition	X	X	X	X	X	X
20	S521*-561 ②	Condenser Partition	X	X	X	X	X	X
21	FAD-NE3	Fresh Air Damper Assembly	X	X	X	X	X	X
22	118-104-* ①	Condenser Grille	X	X	X	X	X	X
22	118-109 ②	Condenser Grille	X	X	X	X	X	X
22	118-147 ③	Condenser Grille	X	X	X	X	X	X
23	S553-523-* ①	Vent Option Door	X	X	X	X	X	X
23	S553-549 ②	Vent Option Door	X	X	X	X	X	X
23	S553-550 ③	Vent Option Door	X	X	X	X	X	X
24	S553-524-* ①	Filter Door	X	X	X	X	X	X
24	S553-553 ②	Filter Door	X	X	X	X	X	X
24	S553-554 ③	Filter Door	X	X	X	X	X	X
25	S514-241-* ①	Upper Front	X	X	X	X	X	X
25	S514-238 ②	Upper Front	X	X	X	X	X	X
25	S514-239 ③	Upper Front	X	X	X	X	X	X
26	121Y467	Blower Partition	X	X	X	X	X	X
27	105Y850	Side Support	X	X	X	X	X	X
28	137-685	Bottom Evaporator Fill	X	X	X	X	X	X
29	S501-936-* ①	Left Side	X	X	X	X	X	X
29	S501-999 ②	Left Side	X	X	X	X	X	X
29	S501-946 ③	Left Side	X	X	X	X	X	X
30	147-044	Evaporator Support	X	X	X	X	X	X
31	S111Y030	Outlet Air Frame Assembly	X	X	X	X	X	X
32	135Y123	Heat Shield	X	X	X	X	X	X
33	109-450	Lower Back	X	X	X	X	X	X
33	109-454 ②	Lower Back	X	X	X	X	X	X
33	109-452 ③	Lower Back	X	X	X	X	X	X
NS	135-329	Air Baffle	X	X	X	X	X	X

① Exterior cabinet parts are manufactured with various paint color options. To ensure the proper paint color is received, include the complete model and serial number of the unit for which cabinet parts are being ordered.

② Exterior cabinet parts are manufactured from stainless steel Code "S"

③ Exterior cabinet parts are manufactured from aluminum Code "A"

FUNCTIONAL COMPONENTS

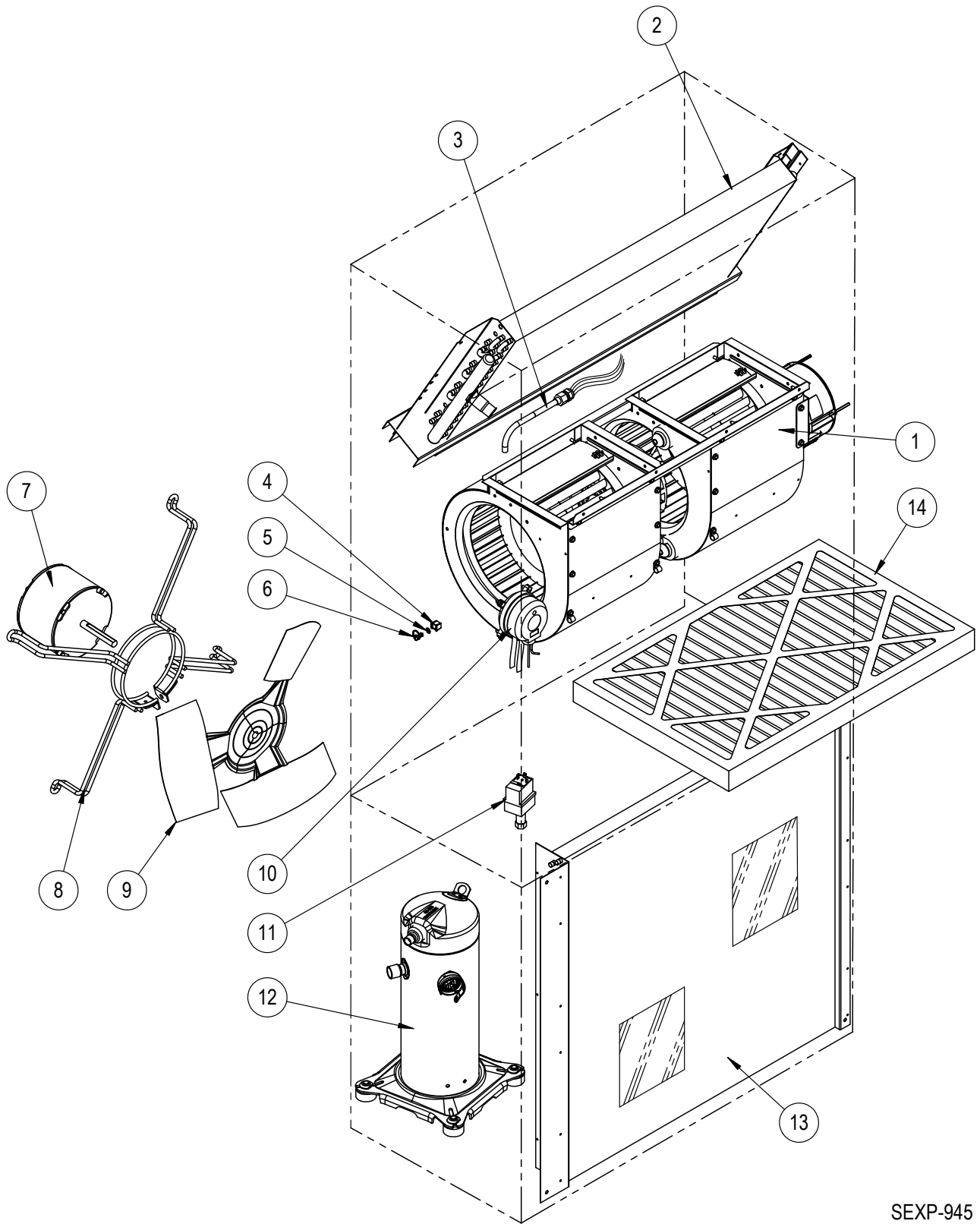

SEXP-945

FUNCTIONAL COMPONENTS

Dwg No.	Part Number	Description	W30LB-A	W30LB-B	W30LB-C	W30LB-F	W36LB-A	W36LB-B	W36LB-C	W36LBRC	W36LB-F
1	900-364-0150BX	Blower Assembly	X	X		X					
1	900-365-0151BX	Blower Assembly			X						
1	900-364-0152BX	Blower Assembly					X	X		X	X
1	900-365-0153BX	Blower Assembly							X		
2	917-0355	Evaporator Coil w/Distributor Assy.	X	X	X	X					
2	917-0356	Evaporator Coil – Coated w/Distributor Assy.	X	X	X	X					
2	917-0357	Evaporator Coil w/Distributor Assy.					X	X	X	X	X
2	917-0358	Evaporator Coil – Coated w/Distributor Assy.					X	X	X	X	X
3	800-0456	Distributor Assembly					X	X	X	X	X
3	800-0479	Distributor Assembly	X	X	X	X					
4	1171-023	1/4" Receptacle	X	X	X	X	X	X	X	X	X
5	1171-024	1/4" Turn Retainer	X	X	X	X	X	X	X	X	X
6	1171-022	1/4" Turn Fastener	X	X	X	X	X	X	X	X	X
7	8103-029	Condenser Motor	X	X			X	X			
7	8103-030	Condenser Motor			X				X	X	
7	8103-013	Condenser Motor				X					X
8	8200-001	Fan Motor Mount	X	X	X	X	X	X	X	X	X
8	8200-050 ①	Stainless Steel Fan Motor Mount	X	X	X	X	X	X	X	X	X
9	S5151-045	Fan Blade	X	X	X	X	X	X	X	X	X
9	S5151C045 ①	Coated Fan Blade	X	X	X	X	X	X	X	X	X
10	CMA-31	Dirty Filter Switch Kit	X	X	X	X	X	X	X	X	X
11	CMA-39	Low Ambient Control (Screw On) ②	X	X	X	X	X	X	X	X	X
12	8000-277	Compressor	X								
12	8000-365	Compressor		X							
12	8000-366	Compressor			X	X					
12	8000-278	Compressor					X				
12	8000-283	Compressor						X			
12	8000-342	Compressor							X	X	X
13	5051-203BX	Condenser Coil	X	X	X	X					
13	5054-203BX	Condenser Coil – Coated	X	X	X	X					
13	5051-202BX	Condenser Coil					X	X	X	X	X
13	5054-202BX	Condenser Coil – Coated					X	X	X	X	X
14	7004-019	Air Filter 1" Throw-Away (16x30x1)	X	X	X	X	X	X	X	X	X
14	7003-031	Air Filter 1" Washable ② (16x30x1)	X	X	X	X	X	X	X	X	X
14	7004-026	Air Filter 2" Pleated ② (16x30x2)	X	X	X	X	X	X	X	X	X
14	7004-048	Air Filter 2" Pleated – MERV 11 ② (16x30x2)	X	X	X	X	X	X	X	X	X
14	7004-062	Air Filter 2" Pleated – MERV 13 ② (16x30x2)	X	X	X	X	X	X	X	X	X
NS	8406-142	High Pressure Switch (Screw On)	X	X	X	X	X	X	X	X	X
NS	8406-140	Low Pressure Switch (Screw On)	X	X	X	X	X	X	X	X	X
NS	5201-021	Filter Drier	X	X	X	X	X	X	X	X	X
NS	5451-024	Tubing Isolation Grommet	X	X	X	X	X	X	X	X	X
NS	6031-009	Coremax Valve Core	X	X	X	X	X	X	X	X	X
NS	1171-028	Filter Door Clip	X	X	X	X	X	X	X	X	X
NS	1171-057	Filter Door Screw	X	X	X	X	X	X	X	X	X
NS	1171-027	Filter Door Screw Retainer	X	X	X	X	X	X	X	X	X
NS	CMC-29	Freeze Thermostat Kit	X	X	X	X	X	X	X	X	X
NS	910-2189	460V Transformer Assembly								X	

NS – Not Shown

① – Used with stainless steel cabinet option

② – Optional on these models

CONTROL PANEL

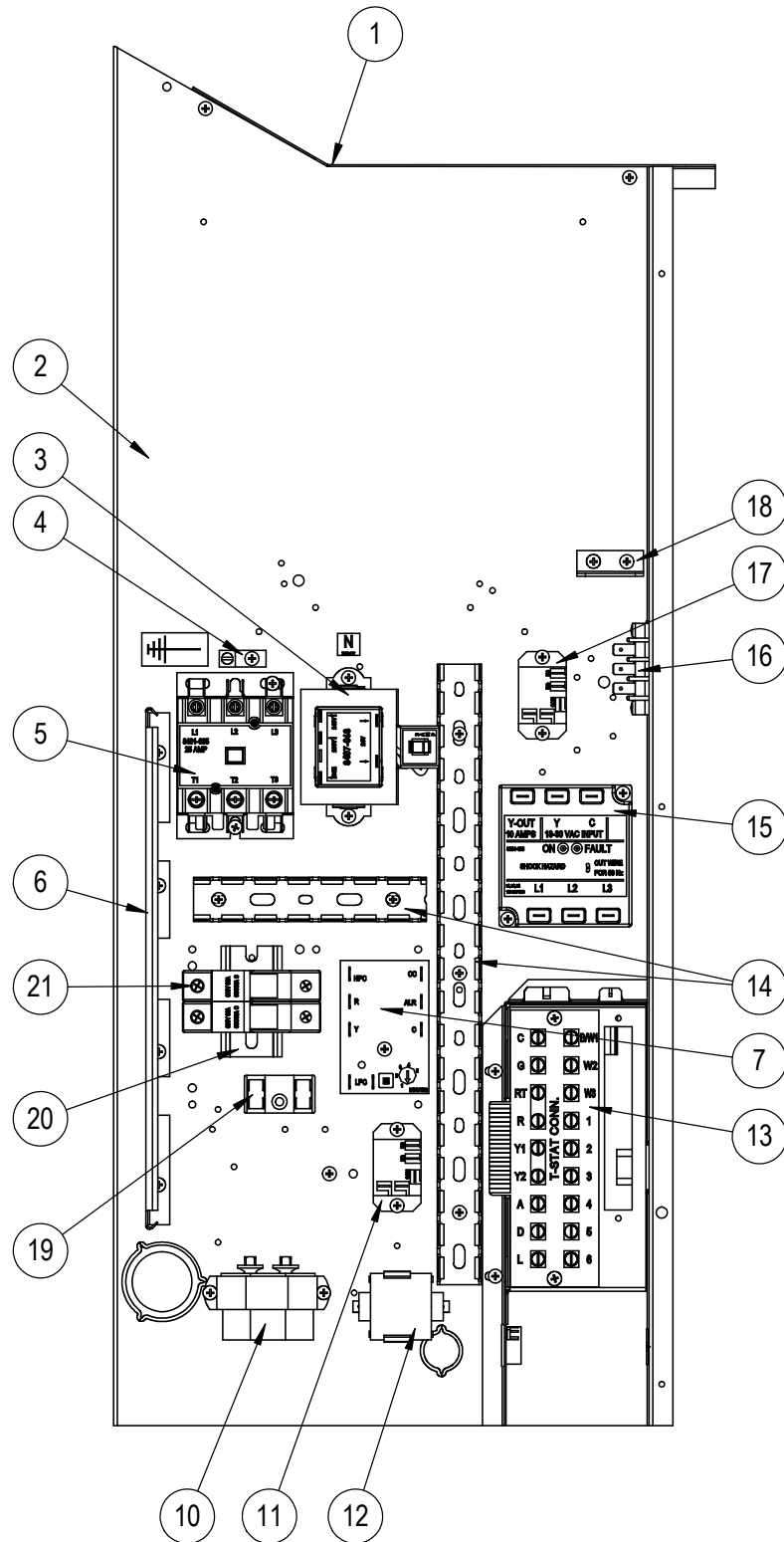

SEXP-947 A

CONTROL PANEL

Dwg No.	Part Number	Description	W30LB-A	W30LB-B	W30LB-C	W30LB-F	W36LB-A	W36LB-B	W36LB-C	W36LBRC	W36LB-F
1	117Y137	Control Panel Top	X	X	X	X	X	X	X	X	X
2	117Y407	Control Panel	X	X	X	X	X	X	X	X	X
3	8407-068	Transformer	X	X		X	X	X			X
3	8407-069	Transformer			X				X	X	
4	8611-006	Ground Terminal	X	X	X	X	X	X	X	X	X
5	8401-033	Compressor Contactor	X				X				
5	8401-035	Compressor Contactor		X	X	X		X	X	X	X
6	135-122	Wire Shield	X	X	X	X	X	X	X	X	X
7	8201-176BX	Compressor Control Module	X	X	X	X	X	X	X	X	X
9	8607-017	Terminal Block (Optional)	X	X	X	X	X	X	X	X	X
10	8552-052	Compressor Capacitor	X				X				
10	S8552-002	Outdoor Motor Capacitor		X	X	X		X	X	X	X
11	8201-062	Alarm Relay (Optional)	X	X	X	X	X	X	X	X	X
12	8551-004	Start Device (PTCR) (Optional)	X	X	X	X	X	X	X	X	X
13	8607-062	Low Voltage Terminal Strip	X	X	X	X	X	X	X	X	X
14	8611-140-1400	Cable Duct – 14" Piece	X	X	X	X	X	X	X	X	X
14	8611-140-0500	Cable Duct – 5" Piece	X	X	X	X	X	X	X	X	X
15	8201-174BX	Phase Monitor		X	X	X		X	X	X	X
16	8607-042	Blower Speed Terminal	X	X	X	X	X	X	X	X	X
17	8201-130	Blower Control Relay	X	X	X	X	X	X	X	X	X
18	141-188	Plug Support Bracket	X	X	X	X	X	X	X	X	X
19	8607-017	Terminal Block								X	
20	8611-210	DIN Rail								X	
21	8614-058	Fuse Block								X	
21	8614-047	3.2A Fuse								2	
NS	8615-038	Circuit Breaker 35A 2 Pole (Opt.) ①	X				X				
NS	8615-054	Circuit Breaker 20A 3 Pole (Opt.) ①		X							
NS	8615-052	Circuit Breaker 30A 3 Pole (Opt.) ①					X				
NS	S8615-067	Toggle Disconnect (Optional) ①			X	X			X	X	X
NS	8607-013	Terminal Block 2 Pole				X					X
NS	113-601	Terminal Block Bracket				X					X
NS	4095-196	Wiring Diagram	X				X				
NS	4095-296	Wiring Diagram		X				X			
NS	4095-378	Wiring Diagram			X				X		
NS	4095-382	Wiring Diagram								X	
NS	4095-640	Wiring Diagram				X					X
NS	3000-1598	Blower Power Plug	X	X	X	X	X	X	X	X	X
NS	3000-1599	Blower Speed Plug	X	X	X	X	X	X	X	X	X
NS	3000-1524	Vent Jumper Plug	X	X	X	X	X	X	X	X	X
NS	3000-1224	Compressor Plug/Harness	X				X				
NS	3000-1231	Compressor Plug/Harness		X	X	X		X	X	X	X
NS	3003-047	Control Panel Harness	X				X				
NS	3003-048	Control Panel Harness		X	X			X	X	X	
NS	3003-049	Control Panel Harness				X					X
NS	3000-1608	Low Voltage Terminal Block Harness	X	X	X	X	X	X	X	X	X
NS	S910-2048	Complete Low Voltage Box Assembly (Sheet Metal, LVTS & Wire Harness)	X	X	X	X	X	X	X	X	X
NS	8201-074	Power Switch Relay	X								

NS = Not Shown

① Circuit breakers listed are for units without electric heat, "OZ" models. See heater replacement parts manual for units with electric heat.

BLOWER ASSEMBLY

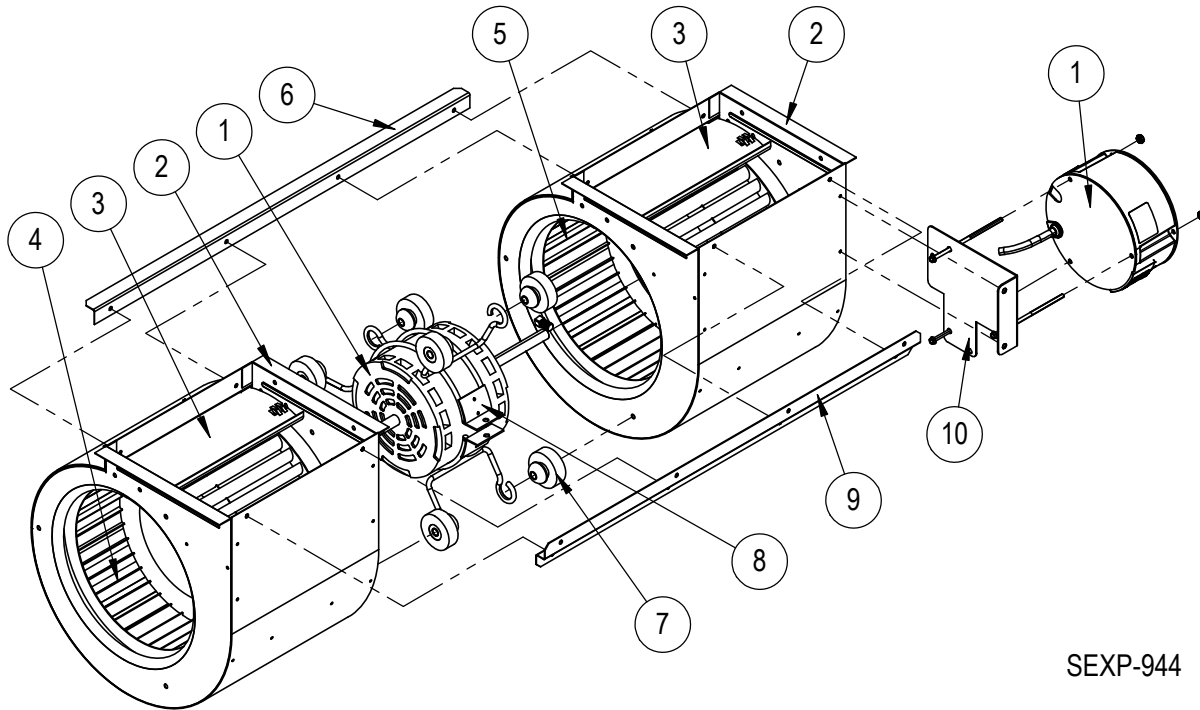

SEXP-944

Dwg No.	Part Number	Description	900-364-0150BX	900-364-0152BX	900-365-0151BX	900-365-0153BX
1	S8106-068-0150	Blower Motor & Control (230/208V)	X			
1	S8106-068-0152	Blower Motor & Control (230/208V)		X		
1	S8106-069-0151	Blower Motor & Control (460V)			X	
1	S8106-069-0153	Blower Motor & Control (460V)				X
1	C8106-068-0150	Programmed Control Only (230/208V)	0			
1	C8106-068-0152	Programmed Control Only (230/208V)		0		
1	C8106-069-0151	Programmed Control Only (460V)			0	
1	C8106-069-0153	Programmed Control Only (460V)				0
2	151-111	Housing	2	2	2	2
3	144-174	Diffuser	2	2	2	2
4	5152-090	Wheel CW	X	X	X	X
5	5152-091	Wheel CCW	X	X	X	X
6	105-870	Back Brace	X	X	X	X
7	5451-011	Grommets	6	6	6	6
8	8200-031	Motor Mount	X	X	X	X
9	103-401	Front Brace	X	X	X	X
10	113-761	Motor Control Bracket	X	X	X	X

X – Standard Component
 O – Optional Component