

---

# REPLACEMENT PARTS MANUAL

---

## MEGA-TEC® Wall Mount Air Conditioner

Models:

W090APB W090APC W090APE W090APV W090APQ  
W120APB W120APC W120APE W120APV W120APQ  
W120AEB W120AEC W120AEE W120AEV W120AEQ

---

### Contents

Description	Page	Description	Page
Cabinet Components		Electric Heat Components	
♦ Exploded View .....	2	♦ Exploded View .....	20
♦ Usage List .....	3	♦ Usage List .....	21
Economizer Intake Hoods		♦ Usage List .....	22
♦ Exploded View .....	4	Intake Damper Assembly	
♦ Usage List .....	5	♦ Exploded View .....	24
System Components		♦ Usage List .....	25
♦ Exploded View .....	6	Exhaust Damper Assembly	
♦ Usage List .....	7	♦ Exploded View .....	26
Fan System Components		♦ Usage List .....	27
♦ Exploded View .....	8		
♦ Usage List .....	9		
Sensors and Peripheral Devices			
♦ Exploded View .....	10		
♦ Usage List .....	11		
Control Panel – B & E Voltage			
♦ Layout View .....	12		
♦ Usage List .....	13		
♦ Usage List .....	14		
Control Panel – C & V Voltage			
♦ Layout View .....	16		
♦ Usage List .....	17		
♦ Usage List .....	18		

### General Notes

- Revised and/or additional pages may be issued from time to time.
- A complete and current manual consists of pages shown in the following contents section.

### Important

- Contact the installing and/or local Bard distributor for all parts requirements. Make sure to have the complete model and serial number available from the unit rating plates.



Bard Manufacturing Company, Inc.  
Bryan, Ohio 43506  
www.bardhvac.com

Manual: 2110-1451B  
Supersedes: 2110-1451A  
Date: 9-20-19

# CABINET COMPONENTS

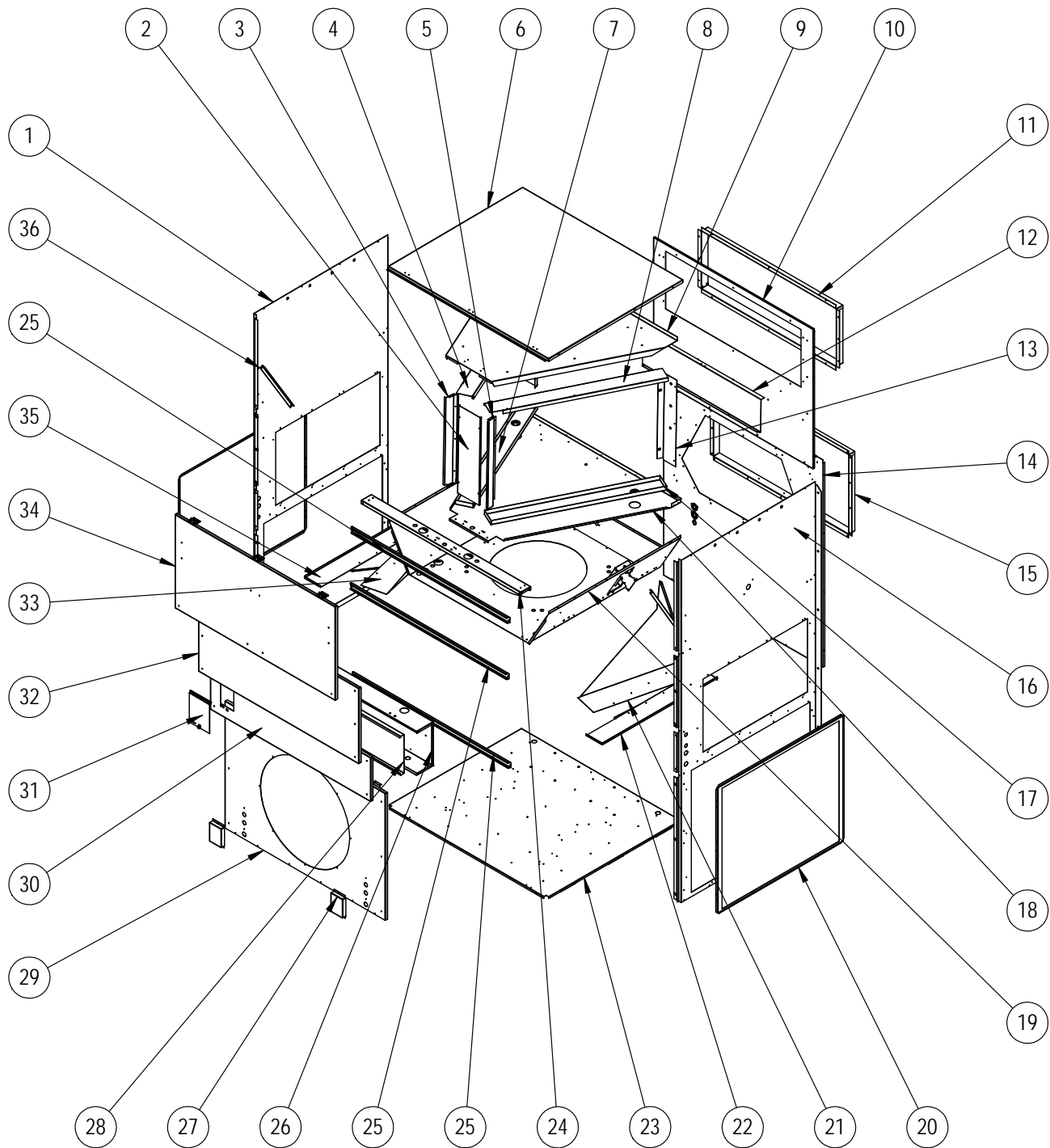

SEXP-897

# CABINET COMPONENTS

Dwg No.	Part Number	Description	W090A ****E	W120A ****E	W090A ****B	W120A ****B
1	501-1038-1	Left Side Assembly (Economizer)	X	X		
1	501-1041-1	Left Side Assembly (Non-Economizer)			X	X
2	113-723	Evaporator Front Fill	X	X	X	X
3	141Y488	Left Front Evaporator Bracket	X	X	X	X
4	137X909	Filter Channel - RH	X	X	X	X
5	141X488	Right Front Evaporator Bracket	X	X	X	X
6	507-379-1	Top	X	X	X	X
7	523-160	Left Drain Pan	X	X	X	X
8	137Y909	Filter Channel - LH	X	X	X	X
9	137-905	Evaporator Top Fill	X	X	X	X
10	509-400	Upper Back	X	X	X	X
11	111-293	Supply Air Frame	X	X	X	X
12	137-914	Insulation Shield	X	X	X	X
13	541-483	RH Rear Evaporator Support	X	X	X	X
NS	541-484	LH Rear Evaporator Support	X	X	X	X
14	509-401	Lower Back (Economizer)	X	X		
14	509-403	Lower Back (Non-Economizer)			X	X
15	111-294	Return Air Frame	X	X	X	X
16	S501-1037-1	Right Side Assembly (Economizer)	X	X		
16	S501-1042-1	Right Side Assembly (Non-Economizer)			X	X
17	523-159	Right Drain Pan	X	X	X	X
18	521-577	Evaporator Partition	X	X	X	X
19	521-578	Blower Partition (Economizer)	X	X		
19	521-580	Blower Partition (Non-Economizer)			X	X
20	118-123-1	Side Grille	2	2	2	2
21	537-908-8	RH Internal Deflector (Economizer)	X	X		
21	135X391	RH Internal Deflector (Non-Economizer)			X	X
22	137X906	RH Condensor Partition	X	X		
22	121-581	Condensor Partition			X	X
23	527-570	Base Assembly	X	X	X	X
24	141-481	Evaporator Partition Front Support	X	X	X	X
25	135-390-1	Service Panel Rain Channel	3	3	3	3
26	517-403	Control Panel Box	X	X	X	X
27	S157-031-1	Refrigerant Service Port Cover	X	X	X	X
28	133-300	Inner Control Panel Cover (230V)		X		X
28	133-312	Inner Control Panel Cover (460V)	X	X	X	X
28	133-313	Inner Control Panel Cover (230V)	X		X	
29	S553-715-1	Condenser/Fan Access Panel	X	X	X	X
NS	167-030-1	Venturi Ring	X	X	X	X
30	533-299-1	Control Panel Access Panel	X	X	X	X
31	S153-716-1	Circuit Breaker Access Panel	X	X	X	X
32	S553-714-1	Blower Access Service Panel	X	X	X	X
33	537-919-8	LH Economizer Internal Deflector	X	X		
33	135Y391	LH Economizer Internal Deflector			X	X
34	S553-713-1	Air Filter/Evaporator Access Door	X	X	X	X
35	137Y906	LH Condensor Partition	X	X	X	X
36	113-733	Evap Door Hinge Arm	2	2	2	2
NS	113-732	Evap Door Arm Bracket	2	2	2	2
NS	113X726	Evap Door Support Guide - LH Side	X	X	X	X
NS	113Y726	Evap Door Support Guide -RH Side	X	X	X	X
NS	113-750-1	Rain Flashing	X	X	X	X
NS	113-748	Lifting Bracket	2	2	2	2
NS	400-0426	Front Door Lifting Handle	2	2	2	2
NS	142-231	Rear Cover Plates (Lower Back)	2	2	2	2

NS – Not Shown

# ECONOMIZER INTAKE HOODS

---

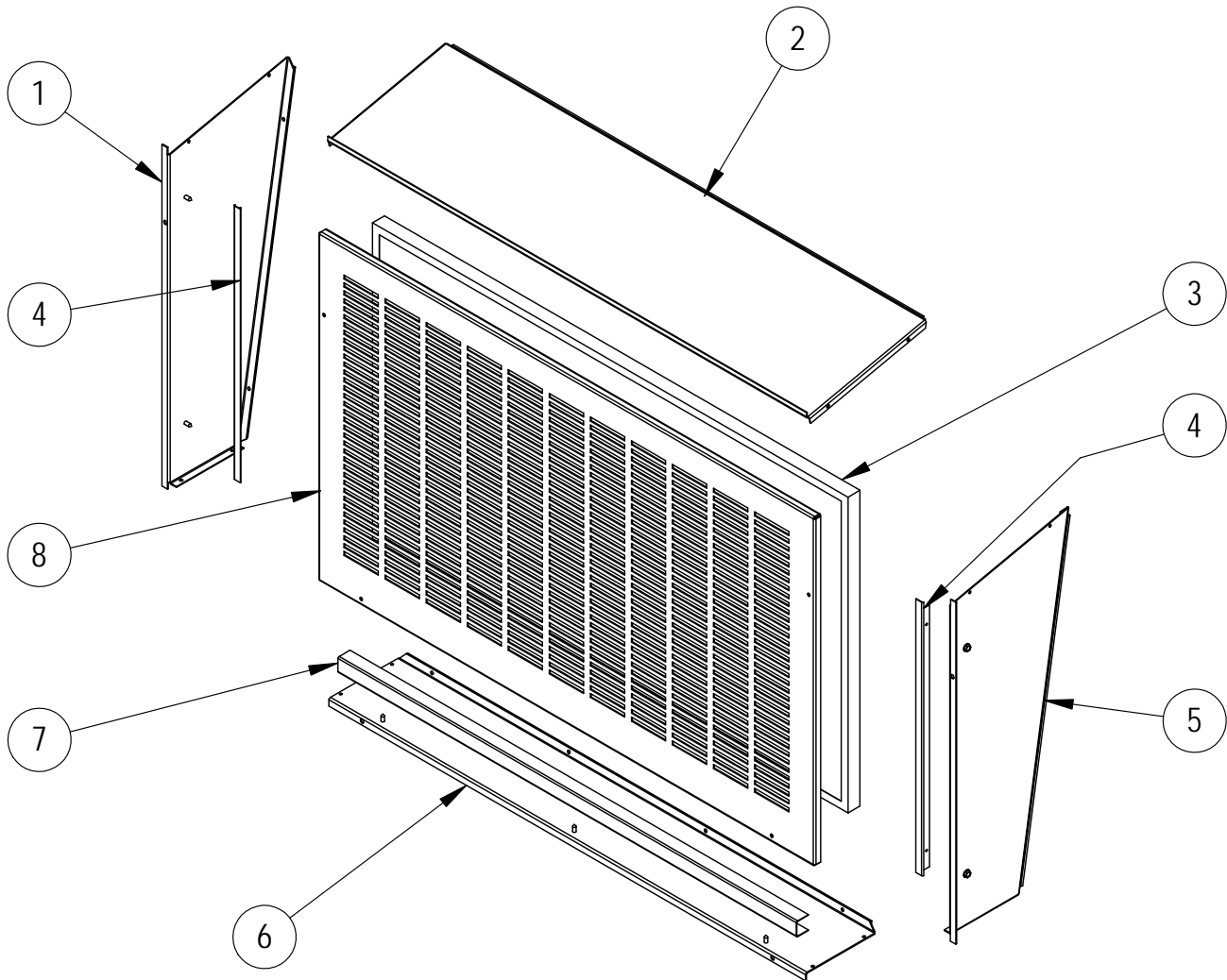

SEXP-899

# ECONOMIZER INTAKE HOODS

---

Dwg No.	Part Number	Description	W090A ****E	W120A ****E
1	101-1039-1	Left Side	X	X
2	107-380-1	Econ Hood Top	X	X
3	7003-081	Mist Eliminator	X	X
4	105-1342	Side Filter Angle	X	X
5	101-1040-1	Right Side	X	X
6	127-571-1	Econ Hood Bottom	X	X
7	113-725	Mist Eliminator Support	X	X
8	119-122-1	Front Grille	X	X

# SYSTEM COMPONENTS

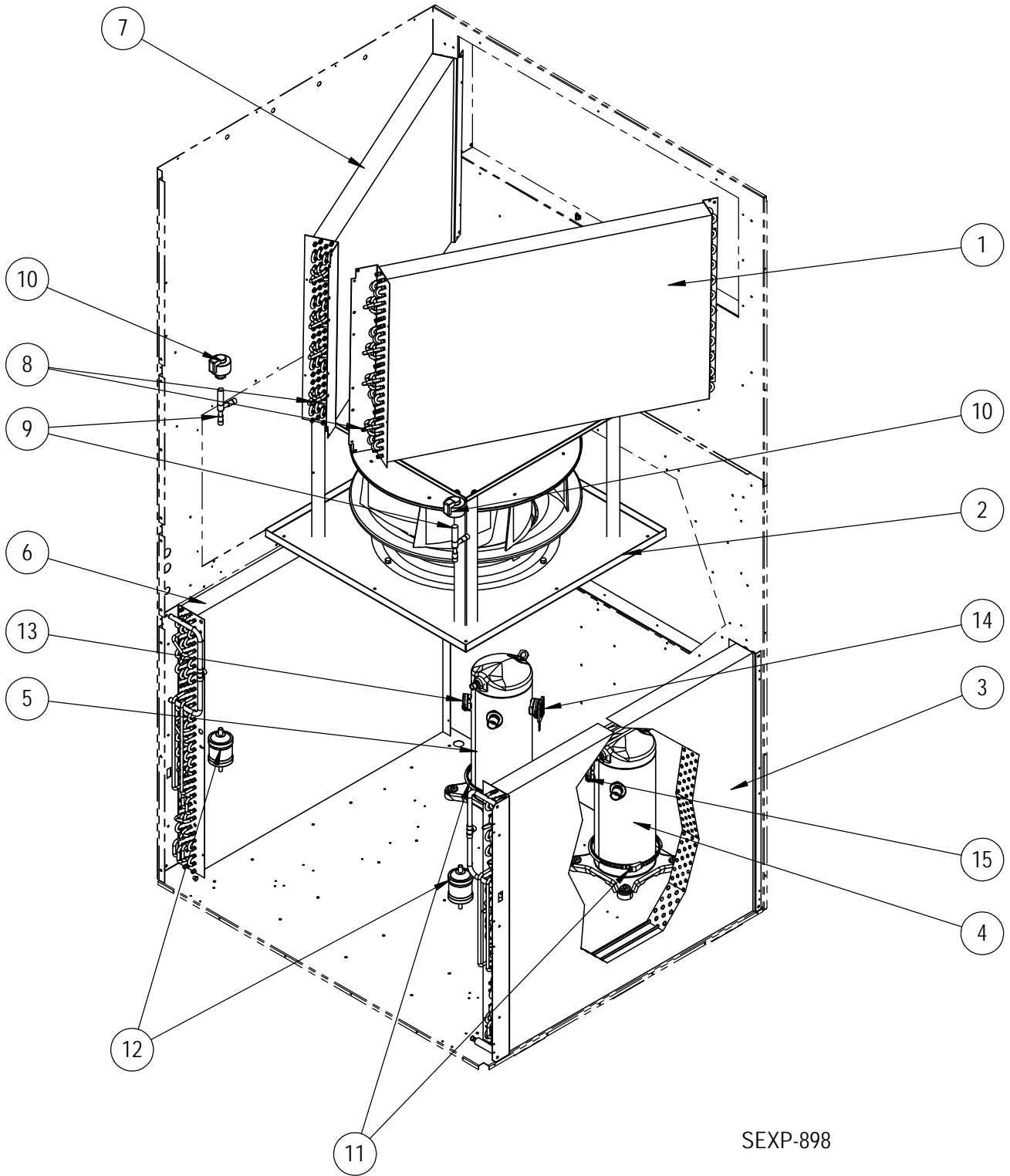

SEXP-898

# SYSTEM COMPONENTS

Dwg. No.	Part Number	Description	W090A*B	W090A*C	W090A*E	W090A*V	W090A*Q	W120A*B	W120A*C	W120A*E	W120A*V	W120A*Q
1	917-0351BX	Right Evaporator Coil (Green Hydrophillic Coated)	X	X	X	X	X	X	X	X	X	X
1	917-0362BX	Right Evaporator Coil (Phenolic Coated)	O	O	O	O	O	O	O	O	O	O
2	S5154-008-001	Indoor Blower Assembly	X		X		X	X		X		X
2	S5154-009-001	Indoor Blower Assembly		X		X			X		X	
3	5051-220BX	Right Condenser Coil	X	X	X	X	X	X	X	X	X	X
3	5054-220BX	Right Condenser Coil (Phenolic Coated)	O	O	O	O	O	O	O	O	O	O
4	8000-333	1-Stage Compressor (ZP42K5E-TF5-130)	X		X							
4	8000-334	1-Stage Compressor (ZP42K5E-TFD-130)		X		X						
4	8000-420	1-Stage Compressor (ZP42K5E-TFE-130)					X					
4	8000-429	1-Stage Compressor (ZP57K5E-TF5-130)						X		X		
4	8000-430	1-Stage Compressor (ZP57K5E-TFD-130)							X		X	
4	8000-431	1-Stage Compressor (ZP57K5E-TFE-130)										X
5	8000-443	2-Stage Compressor (ZPS40K6E-TF5-130)	X		X							
5	8000-444	2-Stage Compressor (ZPS40K6E-TFD-130)		X		X						
5	8000-445	2-Stage Compressor (ZPS40K6E-TFE-130)					X					
5	8000-397	2-Stage Compressor (ZPS60K5E-TF5-130)						X		X		
5	8000-399	2-Stage Compressor (ZPS60K5E-TFD-130)							X		X	
5	8000-432	2-Stage Compressor (ZPS60K5E-TFE-130)										X
6	5051-219BX	Left Condenser Coil	X	X	X	X	X	X	X	X	X	X
6	5054-219BX	Left Condenser Coil (Phenolic Coated)	O	O	O	O	O	O	O	O	O	O
7	917-0352BX	Left Evaporator Coil (Green Hydrophillic Coated)	X	X	X	X	X	X	X	X	X	X
7	917-0363BX	Left Evaporator Coil (Phenolic Coated)	O	O	O	O	O	O	O	O	O	O
8	8620-296	Freeze Stat Sensor (910-2059-951)	X	X	X	X	X	X	X	X	X	X
8	8620-296	Freeze Stat Sensor (910-2059-952)	X	X	X	X	X	X	X	X	X	X
9	5651S245	Electronic Expansion Valve	2	2	2	2	2					
9	5651S248	Electronic Expansion Valve						2	2	2	2	2
10	5651-246	Modulator for Electronic Expansion Valve	2	2	2	2	2	2	2	2	2	2
11	8605-017	Compressor Crankcase Heater	2		2			2		2		
11	8605-018	Compressor Crankcase Heater		2		2			2		2	
11	8605-021	Compressor Crankcase Heater					2					2
12	5201-022	Refrigerant Filter Drier	2	2	2	2	2	2	2	2	2	2
13	3000-1606	LH 2-Stage Compressor Power Plug	X	X	X	X	X	X	X	X	X	X
14	3000-1604	LH 2-Stage Compressor Staging Solenoid Plug	X	X	X	X	X	X	X	X	X	X
15	3000-1605	RH 1-Stage Compressor Power Plug	X	X	X	X	X	X	X	X	X	X

X – Standard Components

O – Optional Components

**NOTE:** Refrigerant pressure switches, transducers and system temperature sensors can be found on pages 10 & 11.

# FAN SYSTEM COMPONENTS

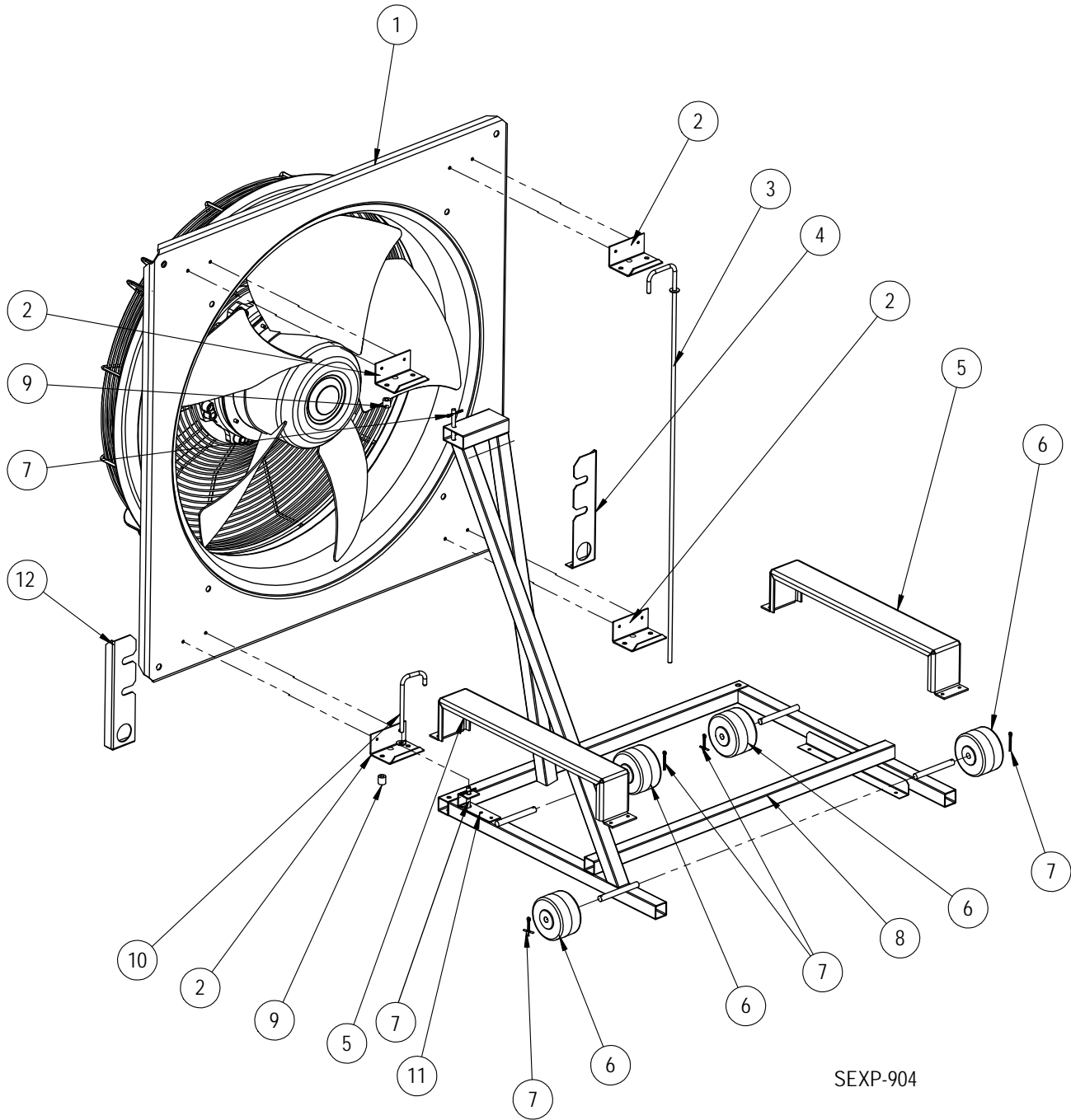

SEXP-904



# FAN SYSTEM COMPONENTS

Dwg No.	Part Number	Description	W090A*B	W120A*B	W090A*C	W120A*C	W090A*E	W120A*E	W090A*V	W120A*V	W090A*Q	W120A*Q
1	S5155-001-001	Fan & Motor Assembly	X	X			X	X				
1	S5155-002-001	Fan & Motor Assembly			X	X			X	X	X	X
2	113-737	Fan Hinge Bracket	4	4	4	4	4	4	4	4	4	4
3	5401-008	Anti-Pivot Rod	X	X	X	X	X	X	X	X	X	X
4	113X729	RH Gauge Port Bracket	X	X	X	X	X	X	X	X	X	X
5	113-735	Wheel Retention Rail	2	2	2	2	2	2	2	2	2	2
6	1171-035	Plastic Wheel, 3" Diameter	4	4	4	4	4	4	4	4	4	4
7	1012-353	Cotter Pin	6	6	6	6	6	6	6	6	6	6
8	8200-056	Fan Slide Welded Frame	X	X	X	X	X	X	X	X	X	X
9	5451-029	Nylon Sleeve	2	2	2	2	2	2	2	2	2	2
10	5401-007	Fan Stop Rod	X	X	X	X	X	X	X	X	X	X
11	113-752	Fan Safety Lock Bracket	X	X	X	X	X	X	X	X	X	X
12	113Y729	LH Gauge Port Bracket	X	X	X	X	X	X	X	X	X	X
NS	113-738	Wheel Guide Angle	2	2	2	2	2	2	2	2	2	2
NS	113-736	Fan Attachment Angle	4	4	4	4	4	4	4	4	4	4

NS – Not Shown

# SENSORS AND PERIPHERAL DEVICES

---

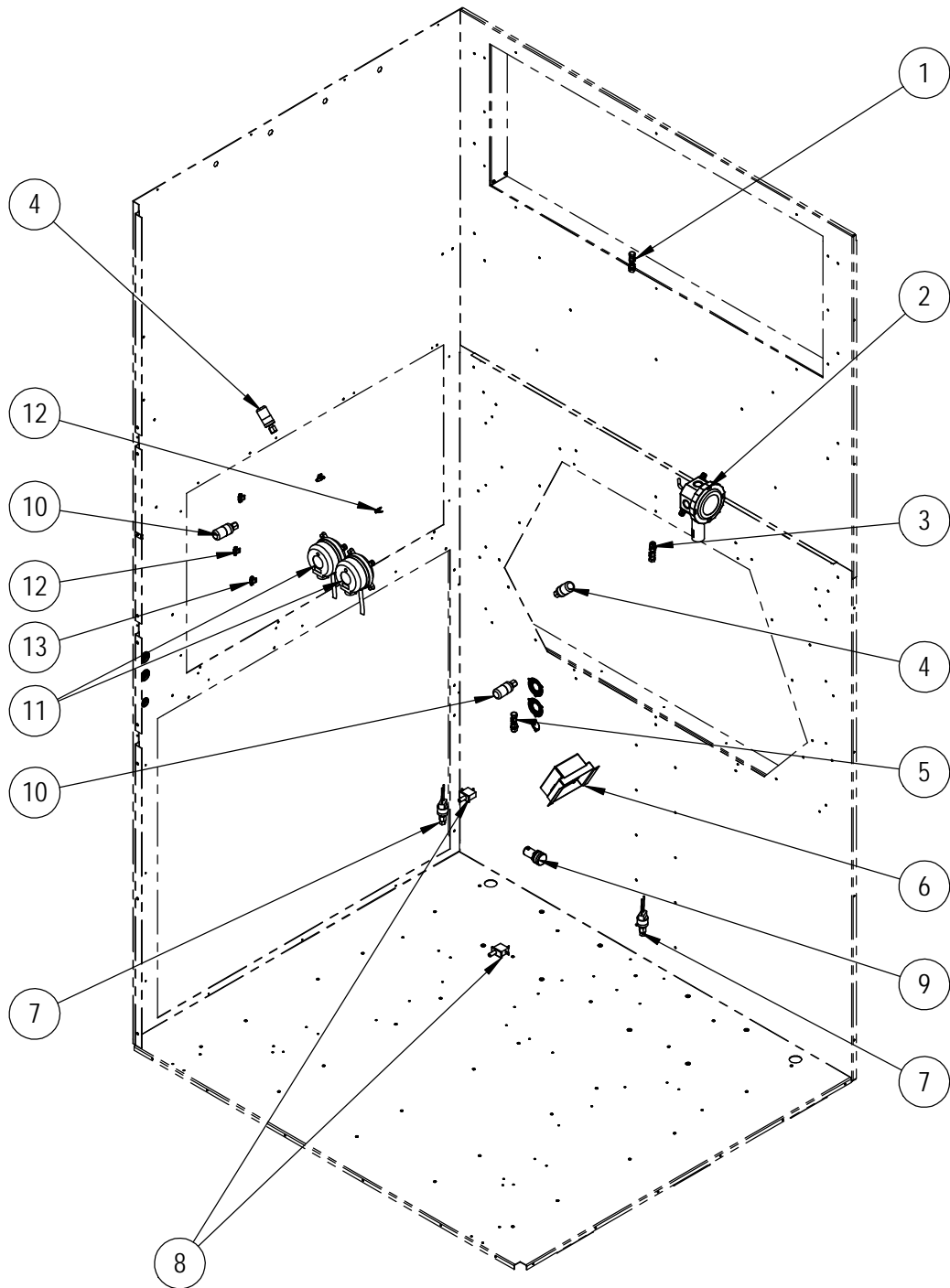

SEXP-905

## SENSORS AND PERIPHERAL DEVICES

---

Dwg No.	Part Number	Description	W090A***E	W120A***E	W090A***B	W120A***B
1	8620-296	Supply Air Sensor (910-2052 SAT)	X	X	X	X
2	8301-089	Outdoor Enthalpy Sensor	X	X	X	X
3	8620-296	Return Air Sensor (910-2054 RAT)	X	X	X	X
4	8406-158	Low Pressure Transducer (Blue)	2	2	2	2
5	8620-296	Mixed Air Sensor (910-2053 MAT)	X	X		
6	8301-073	Dust Sensor	X	X		
NS	8612-061	Dust Sensor Board	X	X		
7	8406-142	High Pressure Switch	2	2	2	2
8	8406-156	Door Switch	2	2	2	2
9	8611-199	Dirty Filter Light	X	X	X	X
10	8406-157	High Pressure Transducer (Red)	2	2	2	2
11	8301-057	Filter Switch w/Adjustment	X	X	X	X
11	8301-057	Blower Fail Switch w/Adjustment	X	X	X	X
12	8620-296	Suction Line Temperature Sensor (910-2084 ST1)	X	X	X	X
12	8620-296	Suction Line Temperature Sensor (910-2076 ST2)	X	X	X	X
13	8620-296	Liquid Line Temperature Sensor (910-2086 LLT1)	X	X	X	X
13	8620-296	Liquid Line Temperature Sensor (910-2077 LLT2)	X	X	X	X

NS – Not Shown

# CONTROL PANEL - B VOLTAGE (230V/208V) & E VOLTAGE (220V/200V)

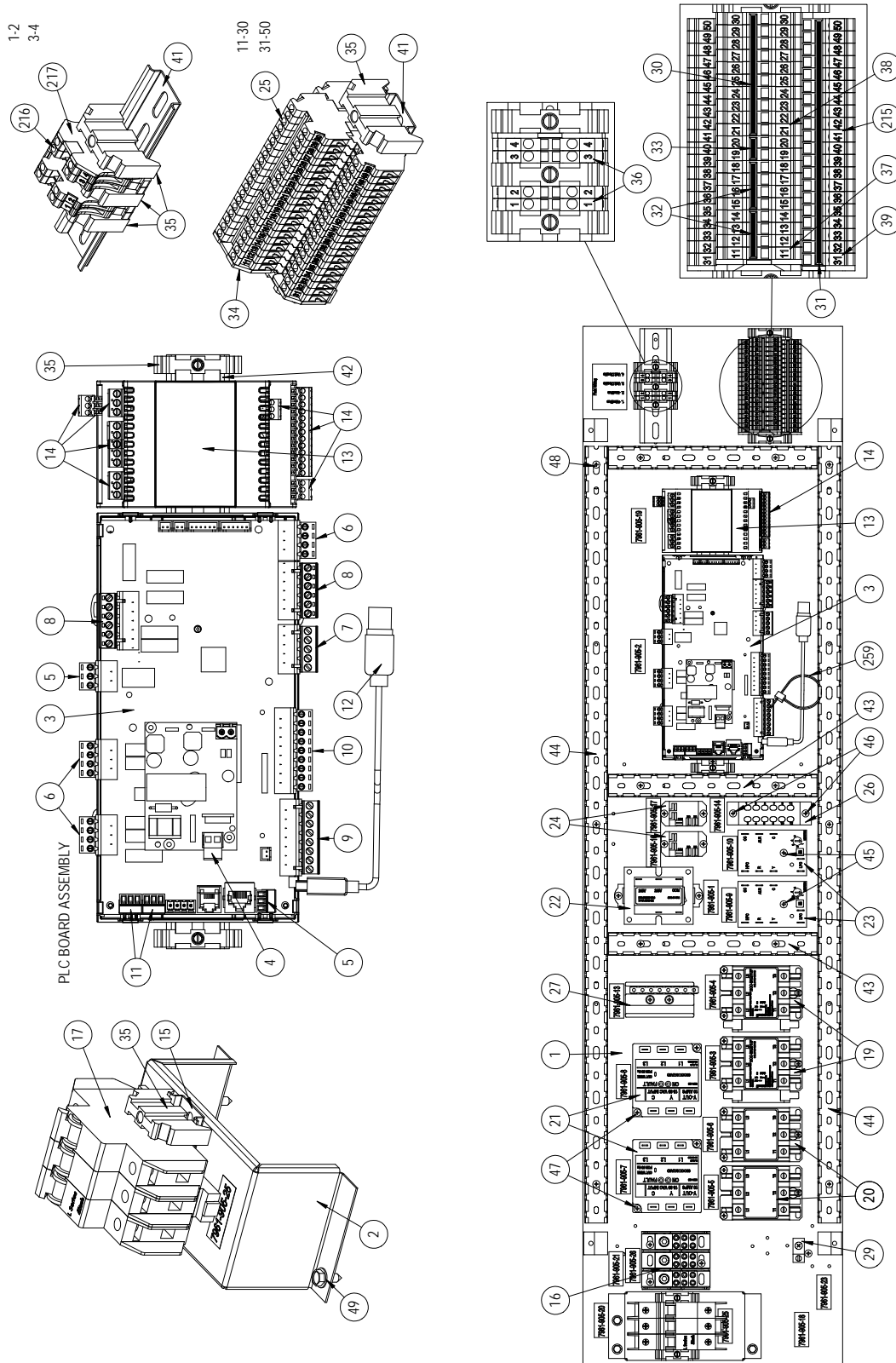

SEXP-992

This drawing to be used for reference for pages 13 and 14

## CONTROL PANEL – B VOLTAGE (230V/208V) & E VOLTAGE (220V/200V)

Dwg No.	Part Number	Description	W090APB0Z W090APE0Z	W090APB09 W090APE09	W090APB18 W090APE18
1	117-404	Control Sub Panel	X	X	X
2	113-734	Circuit Breaker Riser	X	X	X
3	8301-076-002*	UPC3 - MEGA-TEC 1.0.0	X	X	X
4	8611-183	2-Pin Circuit Board Connector	X	X	X
5	8611-147	3-Pin Circuit Board Connector	2	2	2
6	8611-148	4-Pin Circuit Board Connector	3	3	3
7	8611-217	5-Pin Circuit Board Connector	X	X	X
8	8611-218	6-Pin Circuit Board Connector	2	2	2
9	8611-185	8-Pin Circuit Board Connector	X	X	X
10	8611-149	9-Pin Circuit Board Connector	X	X	X
11	8611-192	3-Pin Circuit Board Connector	2	2	2
12	8301-075	USB Micro Cable Female to Male	X	X	X
13	8301-081	C.PCOE Expansion PLC Board	X	X	X
14	8611-226	Terminal Block Kit for C.PCOE	X	X	X
15	8611-240	35MM DIN Rail 3"	X	X	X
16	8607-070	Power Terminal Block		X	X
17	8615-086	Circuit Breaker 60A 3-Pole	X	X	X
19	8401-037	Contact 3-Pole 30 Amp	2	2	2
20	8401-041	Contact 40 Amp 3-Pole		X	2
21	8201-126	3 Phase Line Monitor 50/60 HZ	2	2	2
22	8407-065	Transformer 208/240-24 75VA	X	X	X
23	S8201-164	Compressor Control Module	2	2	2
24	8201-130	Relay, SPDT, Pilot Duty	2	2	2
25	8607-058	Double Level Terminal Block	20	20	20
26	8607-060	Terminal Block Insul. 12-Position	X	X	X
27	8607-061	Terminal Block 16-Position	X	X	X
29	8611-006	Terminal	X	X	X
30	8611-203	Jumper 10-Position	X	X	X
31	8611-224	Jumper 20-Position	X	X	X
32	8611-195	Jumper 4-Position	2	2	2
33	8611-194	Jumper 2-Position	X	X	X
34	8611-221	End Cover	X	X	X
35	8611-144	End Clamp for DIN Rail	9	9	9
36	8607-056	Terminal Designation (1-10)	2	2	2
37	8607-055	Terminal Designation (11-20)	2	2	2
38	8607-054	Terminal Designation (21-30)	2	2	2
39	8607-053	Terminal Designation (31-40)	2	2	2
41	8611-223	35MM DIN Rail 5"	2	2	2
42	8611-228	35MM DIN Rail 13"	X	X	X
43	8611-229-0902	3-1/4" X 1" Cable Duct X 9.13"	3	3	3
44	8611-229-3400	3-1/4" X 1" Cable Duct X 34"	2	2	2
215	8607-059	Terminal Designation (41-50)	2	2	2
216	8611-150	Terminal Block	4	4	4
217	8611-151	End Cap	2	2	2

\* Replacement part will have a letter attached to the end of the part number to designate software version (Example: 8301-076-002A). A software upgrade of all PLCs onsite (units and controllers) should accompany any PLC replacement. Latest revisions of software, change log and instructions are available on the Bard website at <http://www.bardhvac.com/software-download/>

Wiring diagram reference listed under **ELECTRIC HEAT COMPONENTS** on pages 20 & 21.

# CONTROL PANEL – B VOLTAGE (230V/208V) & E VOLTAGE (220V/200V)

Dwg No.	Part Number	Description	W120APB0Z W120APE0Z	W120APB09 W120APE09	W120AEB09	W120APB18 W120APE18	W120AEB18
1	117-404	Control Sub Panel	X	X	X	X	X
2	113-734	Circuit Breaker Riser	X	X	X	X	X
3	8301-076-002*	UPC3 - MEGA-TEC 1.0.0	X	X	X	X	X
4	8611-183	2-Pin Circuit Board Connector	X	X	X	X	X
5	8611-147	3-Pin Circuit Board Connector	2	2	2	2	2
6	8611-148	4-Pin Circuit Board Connector	3	3	3	3	3
7	8611-217	5-Pin Circuit Board Connector	X	X	X	X	X
8	8611-218	6-Pin Circuit Board Connector	2	2	2	2	2
9	8611-185	8-Pin Circuit Board Connector	X	X	X	X	X
10	8611-149	9-Pin Circuit Board Connector	X	X	X	X	X
11	8611-192	3-Pin Circuit Board Connector	2	2	2	2	2
12	8301-075	USB Micro Cable Female to Male	X	X	X	X	X
13	8301-081	C.PCOE Expansion PLC Board	X	X	X	X	X
14	8611-226	Terminal Block Kit for C.PCOE	X	X	X	X	X
15	8615-090	2 Circuit Bus Bar/3 Pole	X	X	X	X	X
16	8615-088	Jumper Bar Main Lugs	3	3	3	3	3
17	8615-084	Circuit Breaker 40A 3-Pole	2	2		2	
17	8615-086	Circuit Breaker 60A 3-Pole			X		2
19	8401-037	Contacto 3-Pole 30 Amp	2	2		2	
20	8401-041	Contacto 40 Amp 3-Pole		X		2	
21	8201-126	3 Phase Line Monitor 50/60 HZ	2	2	2	2	2
22	8407-065	Transformer 208/240-24 75VA	X	X	X	X	X
23	S8201-164	Compressor Control Module	2	2	2	2	2
24	8201-130	Relay, SPDT, Pilot Duty	2	2	2	2	2
25	8607-058	Double Level Terminal Block	20	20	20	20	20
26	8607-060	Terminal Block Insul. 12-Position	X	X	X	X	X
27	8607-061	Terminal Block 16-Position	X	X	X	X	X
29	8611-006	Terminal	2	2	2	2	2
30	8611-203	Jumper 10-Position	X	X	X	X	X
31	8611-224	Jumper 20-Position	X	X	X	X	X
32	8611-195	Jumper 4-Position	2	2	2	2	2
33	8611-194	Jumper 2-Position	X	X	X	X	X
34	8611-221	End Cover	X	X	X	X	X
35	8611-144	End Clamp for DIN Rail	9	9	9	9	9
36	8607-056	Terminal Designation (1-10)	2	2	2	2	2
37	8607-055	Terminal Designation (11-20)	2	2	2	2	2
38	8607-054	Terminal Designation (21-30)	2	2	2	2	2
39	8607-053	Terminal Designation (31-40)	2	2	2	2	2
41	8611-223	35MM DIN Rail 5"	3	3	3	3	3
42	8611-228	35MM DIN Rail 13"	X	X	X	X	X
43	8611-229-0902	3-1/4" X 1" Cable Duct X 9.13"	3	3	3	3	3
44	8611-229-3400	3-1/4" X 1" Cable Duct X 34"	2	2	2	2	2
215	8607-059	Terminal Designation (41-50)	2	2	2	2	2
216	8611-150	Terminal Block	4	4	4	4	4
217	8611-151	End Cap	2	2		2	2
245	8615-077	Circuit Breaker 30A 3-Pole			X		

\* Replacement part will have a letter attached to the end of the part number to designate software version (Example: 8301-076-002A). A software upgrade of all PLCs onsite (units and controllers) should accompany any PLC replacement. Latest revisions of software, change log and instructions are available on the Bard website at <http://www.bardhvac.com/software-download/>

Wiring diagram reference listed under **ELECTRIC HEAT COMPONENTS** on pages 20 & 21.

*This page intentionally left blank*

# CONTROL PANEL - C VOLTAGE (460V) & V VOLTAGE (415/380V)

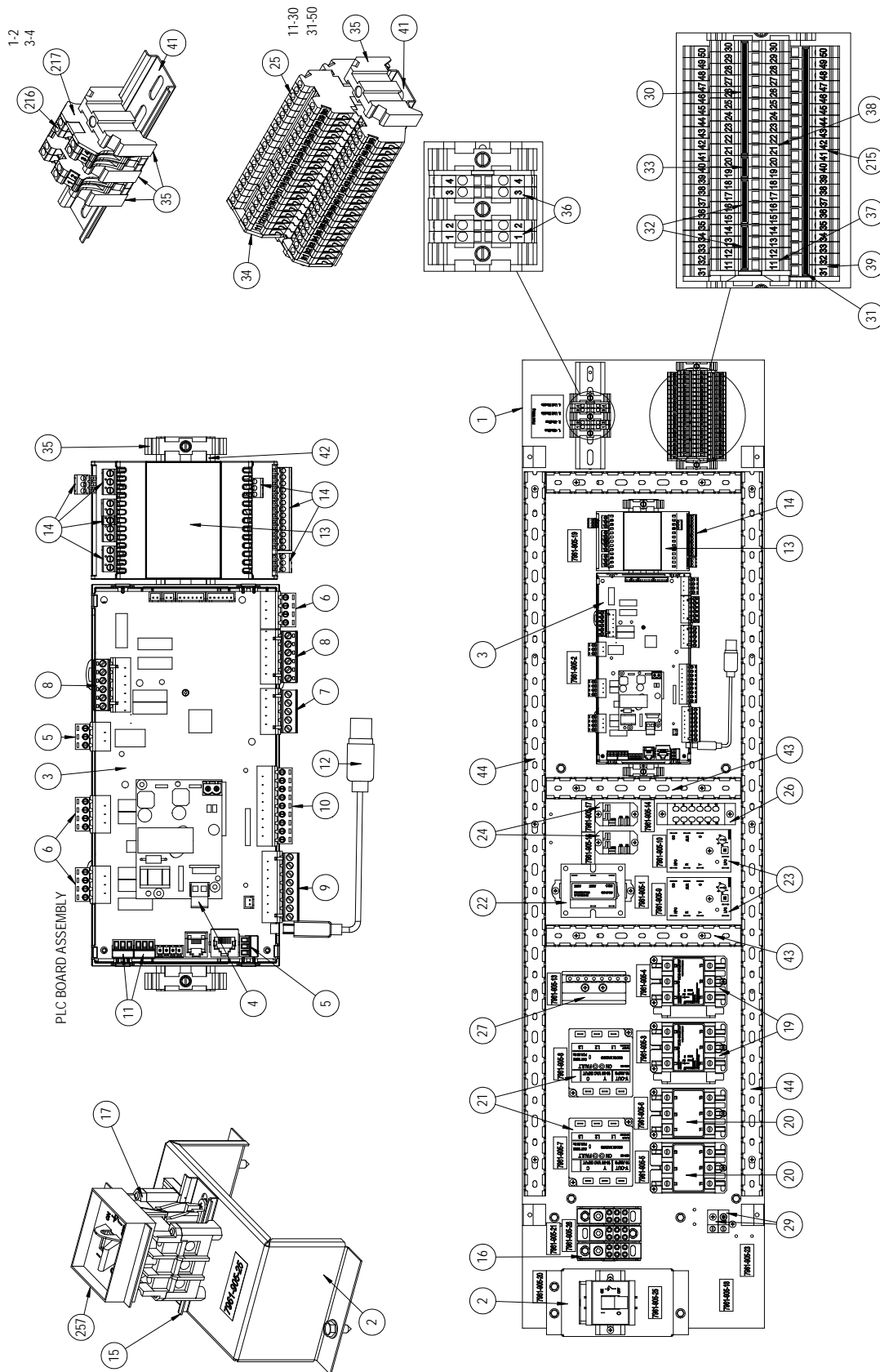

SEXP-921 A

This drawing to be used for reference for pages 17 and 18



## CONTROL PANEL – C VOLTAGE (460V) & V VOLTAGE (415/380V)

Dwg No.	Part Number	Description	W090APC0Z	W090APC09	W090APC18	W090APV0Z	W090APV09	W090APV18
1	117-404	Control Sub Panel	X	X	X	X	X	X
2	113-808	Circuit Breaker Riser	X	X	X	X	X	X
3	8301-076-002*	UPC3 - MEGA-TEC 1.0.0	X	X	X	X	X	X
4	8611-183	2-Pin Circuit Board Connector	X	X	X	X	X	X
5	8611-147	3-Pin Circuit Board Connector	2	2	2	2	2	2
6	8611-148	4-Pin Circuit Board Connector	3	3	3	3	3	3
7	8611-217	5-Pin Circuit Board Connector	X	X	X	X	X	X
8	8611-218	6-Pin Circuit Board Connector	2	2	2	2	2	2
9	8611-185	8-Pin Circuit Board Connector	X	X	X	X	X	X
10	8611-149	9-Pin Circuit Board Connector	X	X	X	X	X	X
11	8611-192	3-Pin Circuit Board Connector	2	2	2	2	2	2
12	8301-075	USB Micro Cable Female to Male	X	X	X	X	X	X
13	8301-081	C.PCOE Expansion PLC Board	X	X	X	X	X	X
14	8611-226	Terminal Block Kit for C.PCOE	X	X	X	X	X	X
15	8615-069	Switch Cover Plate	X	X	X	X	X	X
16	8607-070	Power Terminal Block 3-Pole	X	X	X	X	X	X
17	8615-067	460V 40A Toggle Disconnect	X	X	X	X	X	X
19	8401-037	Contactora 3-Pole 30 Amp	2	2	2	2	2	2
20	8401-041	Contactora 40 Amp 3-Pole		1	2		1	2
21	8201-126	3 Phase Line Monitor 50/60 HZ	2	2	2	2	2	2
22	8407-065	Transformer 208/240-24 75VA	X	X	X	X	X	X
23	S8201-164	Compressor Control Module	2	2	2	2	2	2
24	8201-130	Relay, SPDT, Pilot Duty	2	2	2	2	2	2
25	8607-058	Double Level Terminal Block	20	20	20	20	20	20
26	8607-060	Terminal Block Insul. 12-Position	X	X	X	X	X	X
27	8607-061	Terminal Block 16-Position	X	X	X	X	X	X
29	8611-006	Terminal	2	2	2	2	2	2
30	8611-203	Jumper 10-Position	X	X	X	X	X	X
31	8611-224	Jumper 20-Position	X	X	X	X	X	X
32	8611-195	Jumper 4-Position	2	2	2	2	2	2
33	8611-194	Jumper 2-Position	X	X	X	X	X	X
34	8611-221	End Cover	X	X	X	X	X	X
35	8611-144	End Clamp for DIN Rail	9	9	9	9	9	9
36	8607-056	Terminal Designation (1-10)	2	2	2	2	2	2
37	8607-055	Terminal Designation (11-20)	2	2	2	2	2	2
38	8607-054	Terminal Designation (21-30)	2	2	2	2	2	2
39	8607-053	Terminal Designation (31-40)	2	2	2	2	2	2
41	8611-223	35MM DIN Rail 5"	2	2	2	2	2	2
42	8611-228	35MM DIN Rail 13"	X	X	X	X	X	X
43	8611-229-0902	3-1/4" X 1" Cable Duct X 9.13"	3	3	3	3	3	3
44	8611-229-3400	3-1/4" X 1" Cable Duct X 34"	2	2	2	2	2	2
215	8607-059	Terminal Designation (41-50)	2	2	2	2	2	2
216	8611-150	Terminal Block	4	4	4	4	4	4
217	8611-151	End Cap	2	2	2	2	2	2
257	8615-069	Switch Cover Plate	X	X	X	X	X	X

\* Replacement part will have a letter attached to the end of the part number to designate software version (Example: 8301-076-002A). A software upgrade of all PLCs onsite (units and controllers) should accompany any PLC replacement. Latest revisions of software, change log and instructions are available on the Bard website at <http://www.bardhvac.com/software-download/>

Wiring diagram reference listed under **ELECTRIC HEAT COMPONENTS** on pages 20 & 21.

# CONTROL PANEL – C VOLTAGE (460V) & V VOLTAGE (415/380V)

Dwg No.	Part Number	Description	W120APC0Z	W120APC09	W120APC18	W120APV0Z	W120APV09	W120APV18	W120AEC09	W120AEC18
1	117-404	Control Sub Panel	X	X	X	X	X	X	X	X
2	113-808	Circuit Breaker Riser	X	X	X	X	X	X	X	X
3	8301-076-002*	UPC3 - MEGA-TEC 1.0.0	X	X	X	X	X	X	X	X
4	8611-183	2-Pin Circuit Board Connector	X	X	X	X	X	X	X	X
5	8611-147	3-Pin Circuit Board Connector	2	2	2	2	2	2	2	2
6	8611-148	4-Pin Circuit Board Connector	3	3	3	3	3	3	3	3
7	8611-217	5-Pin Circuit Board Connector	X	X	X	X	X	X	X	X
8	8611-218	6-Pin Circuit Board Connector	2	2	2	2	2	2	2	2
9	8611-185	8-Pin Circuit Board Connector	X	X	X	X	X	X	X	X
10	8611-149	9-Pin Circuit Board Connector	X	X	X	X	X	X	X	X
11	8611-192	3-Pin Circuit Board Connector	2	2	2	2	2	2	2	2
12	8301-075	USB Micro Cable Female to Male	X	X	X	X	X	X	X	X
13	8301-081	C.PCOE Expansion PLC Board	X	X	X	X	X	X	X	X
14	8611-226	Terminal Block Kit for C.PCOE	X	X	X	X	X	X	X	X
15	8615-069	Switch Cover Plate	X	X	X	X	X	X	X	X
16	8607-070	Power Terminal Block 3-Pole	X	X	X	X	X	X	X	X
17	8615-067	460V 40A Toggle Disconnect	X	X	X	X	X			
17	8615-094	460V 60A Toggle Disconnect							X	X
19	8401-037	Contactora 3-Pole 30 Amp	2	2	2	2	2	2	2	2
20	8401-041	Contactora 40 Amp 3-Pole		1	2		1	2	2	2
21	8201-126	3 Phase Line Monitor 50/60 HZ	2	2	2	2	2	2	2	2
22	8407-065	Transformer 208/240-24 75VA	X	X	X	X	X	X	X	X
23	S8201-164	Compressor Control Module	2	2	2	2	2	2	2	2
24	8201-130	Relay, SPDT, Pilot Duty	2	2	2	2	2	2	2	2
25	8607-058	Double Level Terminal Block	20	20	20	20	20	20	20	20
26	8607-060	Terminal Block Insul. 12-Position	X	X	X	X	X	X	X	X
27	8607-061	Terminal Block 16-Position	X	X	X	X	X	X	X	X
29	8611-006	Terminal	2	2	2	2	2	2	2	2
30	8611-203	Jumper 10-Position	X	X	X	X	X	X	X	X
31	8611-224	Jumper 20-Position	X	X	X	X	X	X	X	X
32	8611-195	Jumper 4-Position	2	2	2	2	2	2	2	2
33	8611-194	Jumper 2-Position	X	X	X	X	X	X	X	X
34	8611-221	End Cover	X	X	X	X	X	X	X	X
35	8611-144	End Clamp for DIN Rail	9	9	9	9	9	9	9	9
36	8607-056	Terminal Designation (1-10)	2	2	2	2	2	2	2	2
37	8607-055	Terminal Designation (11-20)	2	2	2	2	2	2	2	2
38	8607-054	Terminal Designation (21-30)	2	2	2	2	2	2	2	2
39	8607-053	Terminal Designation (31-40)	2	2	2	2	2	2	2	2
41	8611-223	35MM DIN Rail 5"	2	2	2	2	2	2	2	2
42	8611-228	35MM DIN Rail 13"	X	X	X	X	X	X	X	X
43	8611-229-0902	3-1/4" X 1" Cable Duct X 9.13"	3	3	3	3	3	3	3	3
44	8611-229-3400	3-1/4" X 1" Cable Duct X 34"	2	2	2	2	2	2	2	2
215	8607-059	Terminal Designation (41-50)	2	2	2	2	2	2	2	2
216	8611-150	Terminal Block	4	4	4	4	4	4	4	4
217	8611-151	End Cap	2	2	2	2	2	2	2	2
257	8615-069	Switch Cover Plate	X	X	X	X	X	X	X	X

\* Replacement part will have a letter attached to the end of the part number to designate software version (Example: 8301-076-002A). A software upgrade of all PLCs onsite (units and controllers) should accompany any PLC replacement. Latest revisions of software, change log and instructions are available on the Bard website at <http://www.bardhvac.com/software-download/>

Wiring diagram reference listed under **ELECTRIC HEAT COMPONENTS** on pages 20 & 21.

*This page intentionally left blank*

# ELECTRIC HEAT COMPONENTS

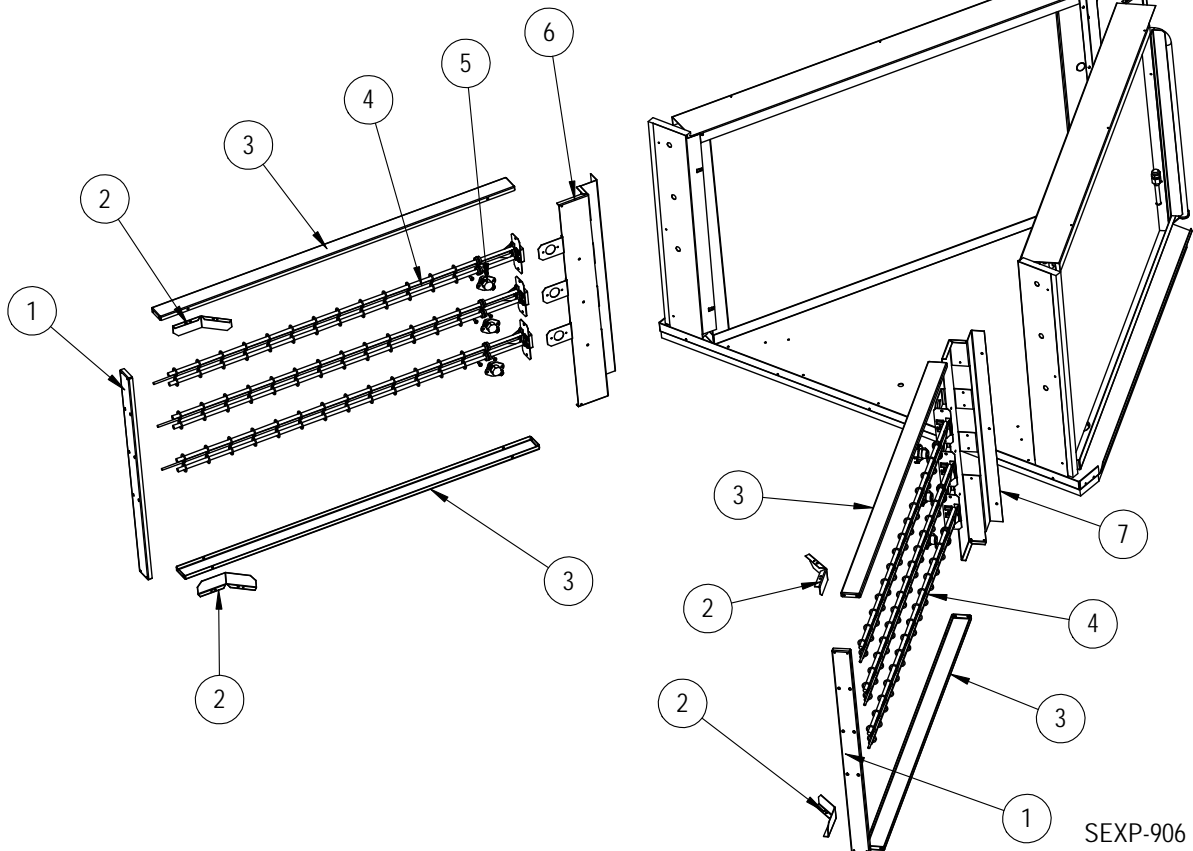
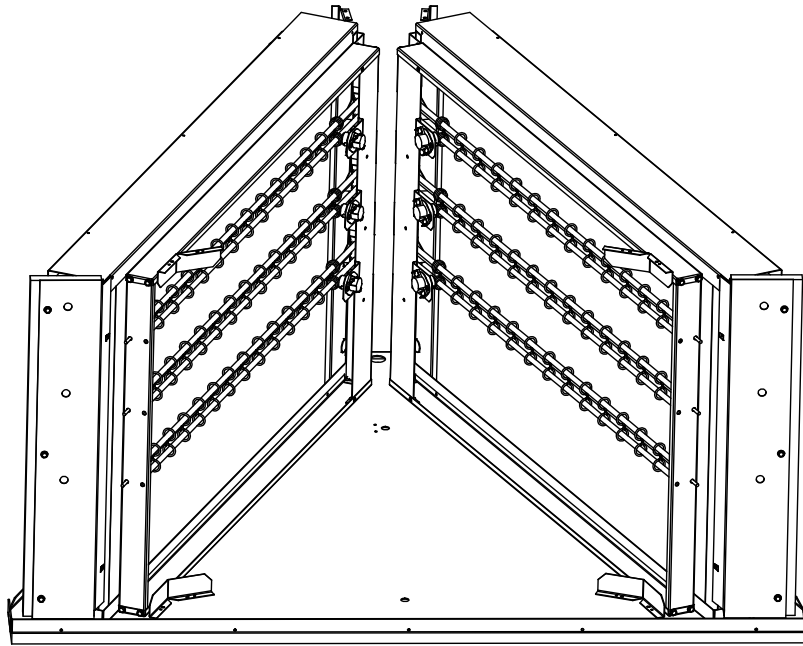

SEXP-906

# ELECTRIC HEAT COMPONENTS

Dwg No.	Part Number	Description	W090APB0Z	W090APB09	W090APB18	W090APC0Z	W090APC09	W090APC18	W090APE0Z	W090APE09	W090APE18	W090APV0Z	W090APV09	W090APV18	W090APQ0Z	W090APQ09	W090APQ18
1	113-759	Heater Assembly Frame, Rear		X 2		X 2		X 2		X 2		X 2		X 2		X 2	
2	113-770	Heater Package Guides		2 4		2 4		2 4		2 4		2 4		2 4		2 4	
3	113-758	Heater Assembly Frame Top/Bottom		2 4		2 4		2 4		2 4		2 4		2 4		2 4	
4	8604-151	Heater Element, 3KW, 208/240V, 2-Term	3 6				3 6		3 6								
4	8604-152	Heater Element, 3KW, 460V, 2-Term					3 6						3 6				
4	8604-153	Heater Element, 3 KW, 575V, 2-Term														3 6	
5	8402-190	Limit Control	3 6				3 6										
5	8402-192	Limit Control							3 6				3 6				
5	8402-198	Limit Control														3 6	
6	113X756	Right Heater Frame Front		X			X			X			X				X
7	113Y756	Left Heater Frame Front		X X			X X			X X			X X				X X
NS	4212-200	Wiring Diagram	X						X								
NS	4212-201	Wiring Diagram		X						X							
NS	4212-202	Wiring Diagram			X						X						
NS	4212-300	Wiring Diagram				X						X					
NS	4212-301	Wiring Diagram					X						X				
NS	4212-302	Wiring Diagram						X						X			
NS	4212-700	Wiring Diagram													X		
NS	4212-701	Wiring Diagram														X	
NS	4212-702	Wiring Diagram															X

NS – Not Shown

# ELECTRIC HEAT COMPONENTS

Dwg No.	Part Number	Description	W120APB0Z	W120APB09	W120AEB09	W120APB18	W120AEB18	W120APC0Z	W120APC09	W120AEC09	W120APC18	W120AEC18	W120APE0Z	W120APE09	W120AEE09	W120APE18	W120AEE18	W120APV0Z	W120APV09	W120AEV09	W120APV18	W120AEV18	W120APQ0Z	W120APQ09	W120AEQ09	W120APQ18	W120AEQ18	
1	113-759	Heater Assembly Frame, Rear		X	X	2	2		X	X	2	2		X	X	2	2		X	X	2	2		X	X	2	2	
2	113-770	Heater Package Guides		2	2	4	4		2	2	4	4		2	2	4	4		2	2	4	4		2	2	4	4	
3	113-758	Heater Assembly Frame Top/Bottom		2	2	4	4		2	2	4	4		2	2	4	4		2	2	4	4		2	2	4	4	
4	8604-151	Heater Element, 3KW, 208/240V, 2-Term		3	3	6	6							3	3	6	6											
4	8604-152	Heater Element, 3KW, 460V, 2-Term							3	3	6	6							3	3	6	6						
4	8604-153	Heater Element, 3 KW, 575V, 2-Term																						3	3	6	6	
5	8402-190	Limit Control		3	3	6	6		3	3	6	6																
5	8402-192	Limit Control												3	3	6	6		3	3	6	6						
5	8402-198	Limit Control																						3	3	6	6	
6	113X756	Right Heater Frame Front				X	X				X	X				X	X				X	X				X	X	
7	113Y756	Left Heater Frame Front		X	X	X	X		X	X	X	X		X	X	X	X		X	X	X	X		X	X	X	X	
NS	4212-200	Wiring Diagram	X										X															
NS	4212-201	Wiring Diagram		X	X									X	X													
NS	4212-202	Wiring Diagram				X	X									X	X											
NS	4212-300	Wiring Diagram						X										X										
NS	4212-301	Wiring Diagram							X	X									X	X								
NS	4212-302	Wiring Diagram									X	X									X	X						
NS	4212-700	Wiring Diagram																					X					
NS	4212-701	Wiring Diagram																						X	X			
NS	4212-702	Wiring Diagram																								X	X	

NS – Not Shown

Refer to drawing on page 20

*This page intentionally left blank*

# INTAKE DAMPER ASSEMBLY

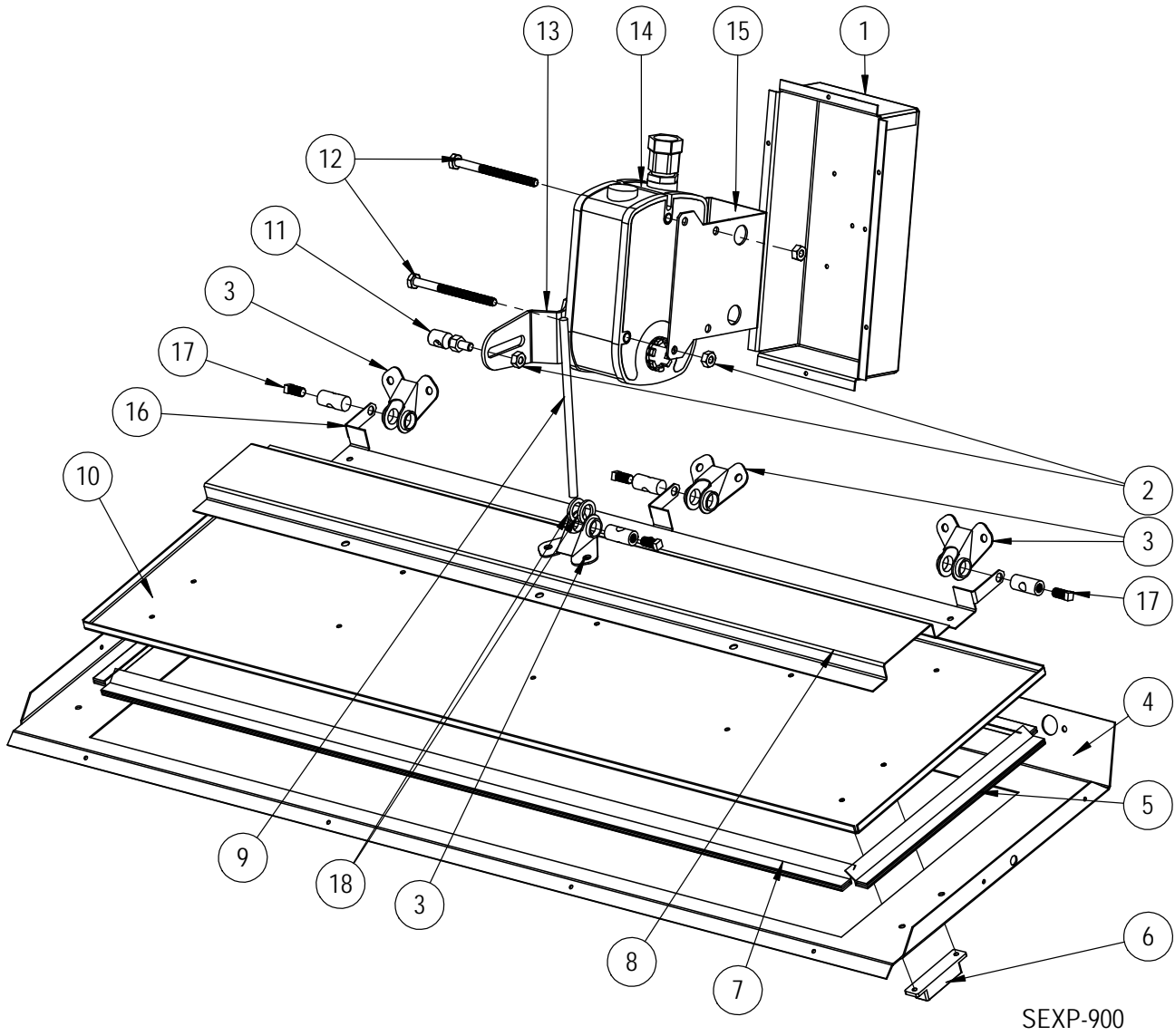



# INTAKE DAMPER ASSEMBLY

Dwg. No.	Part Number	Description	W090A****E W120A****E
1	135-388	Recessed Actuator Box	2
2	1012-201	1/4"-20 Steel Keps Nut	4
3	8602-040	BKP-24 Butterfly Pivot	8
4	137-904	Intake Partition	2
5	1921-067-0900	9" Damper Blade Seal	4
6	8406-150	Blade Switch	2
7	1921-067-3012	30-3/4" Damper Blade Seal	4
8	141-486	Damper Blade Support	2
9	8602-042	1/4" X 6" Rod	2
10	139-396	Damper Blade	2
11	8602-008	Ball Joint	2
12	1012-174	1/4"-20 x 3-1/4" Bolt	4
13	8602-078	Crank Arm	2
14	910-2082	Direct Coupled Actuator w/Crank Arm (Right Side)	1
14	910-2083	Direct Coupled Actuator w/Crank Arm (Left Side)	1
14	8602-098	Actuator Only	1
15	113-727	Actuator Mounting Bracket	2
16	113-730	Hinge Bracket	2
17	1012-343	1/4"-28 x 1/2" Bolt	6
18	1012-348	1/2" x 3/4" Nylon Flat Washer	4

# EXHAUST DAMPER ASSEMBLY

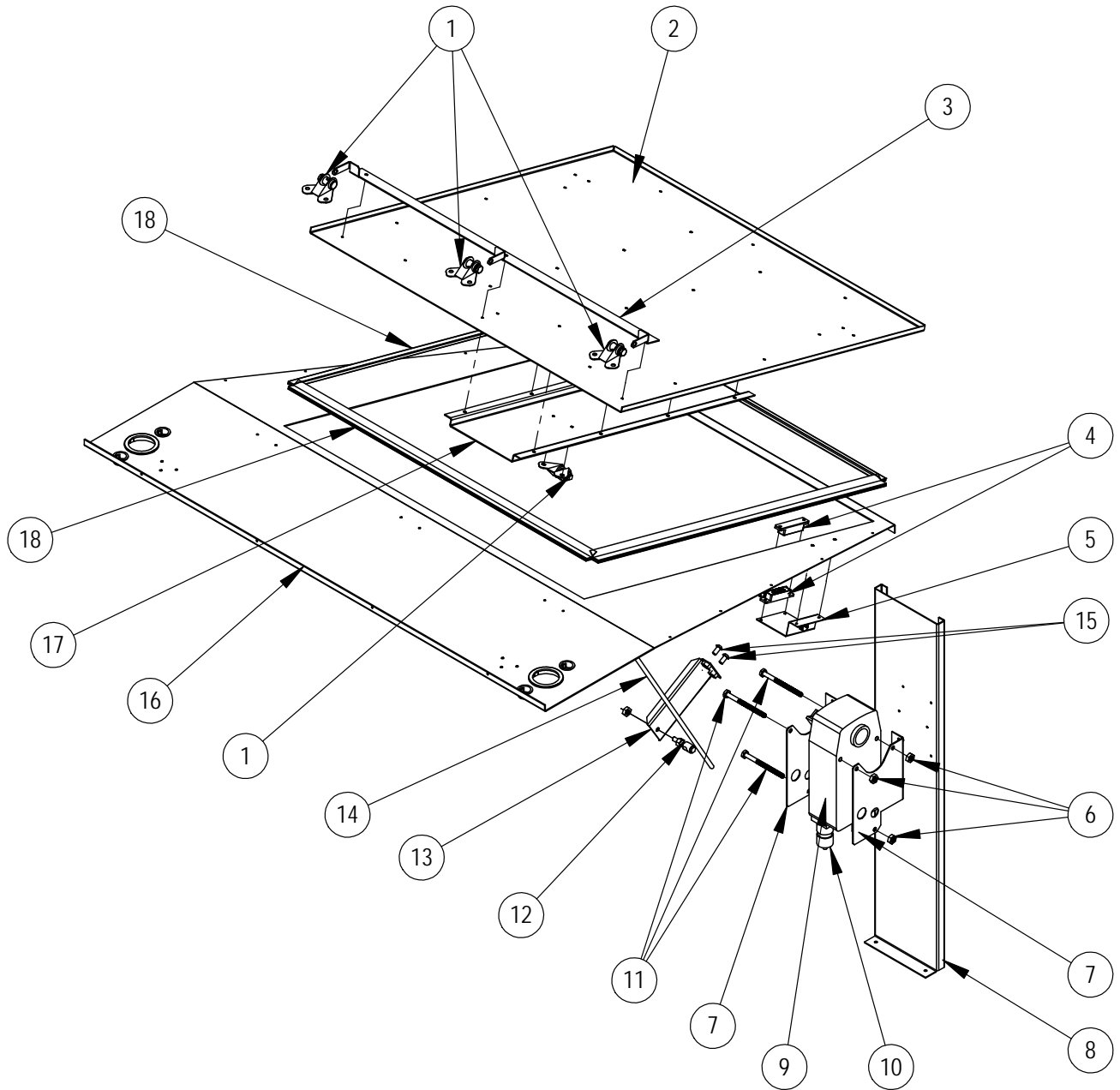

SEXP-901

# EXHAUST DAMPER ASSEMBLY

Dwg. No.	Part Number	Description	W090A****E W120A****E		W090A****B W120A****B	
1	8602-040	BKP-24 Butterfly Pivot	4			
2	539-395	Exhaust Damper Blade	X			
NS	113-747	Exhaust Damper Blade Stiffening Angle	2			
3	113-731	Hinge Bracket	X			
4	8406-150	Blade Switch	X			
5	113-743	Blade Switch Bracket	X			
6	1012-201	1/4"-20 Steel Keps Nut	3			
7	113-728	Actuator Mounting Bracket	2			
8	141-485	Actuator Mounting Plate	X			
9	8602-093	Actuator 2-10V 88 IN/LB	X			
10	8602-100	Terminal Strip Cover	X			
11	1012-174	1/4"-20 x 3-1/4" Bolt	3			
12	8602-008	Ball Joint	X			
13	139-399	Actuator Arm	2			
14	8602-097	1/4" x 16-5/8" Rod	X			
NS	1012-348	1/2" x 3/4" Nylon Flat Washer	2			
15	1012-351	1/4"-20 X 1/2" BTNHD Cap Screw	2			
16	S121-579	Condenser Partition	X			
16	S121-581	Condenser Partition			X	
17	141-487	Exhaust Actuator Support	X			
18	1921-067-2513	25-13/16" Damper Blade Seal				