REPLACEMENT PARTS MANUAL

Wall Mount Air Conditioner

Models:

W42AC-A	W48AC-A	W60AC-A	W72AC-A
W42AC-B	W48AC-B	W60AC-B	W72AC-B
W42AC-C	W48AC-C	W60AC-C	W72AC-C
W42AC-E	W48AC-E	W60AC-E	W72AC-F
W42AC-F	W48AC-F	W60AC-F	W72ACDA
W42ACDA	W48ACDA	W60ACDA	W72ACDB
W42ACDB	W48ACDB	W60ACDB	W72ACDC
W42ACDC	W48ACDC	W60ACDC	W72ACRC
W42ACRC	W48ACRC	W60ACRC	

Contents

Description	Page	Description	Page
External Parts – Standard & Dehum.		Control Panel – Standard & Dehum.	
♦ Exploded View	2	♦ Layout View	14
♦ Usage List	3	♦ Usage List	15
♦ Usage List	4	♦ Usage List	16
Internal Parts – Standard & Dehum.		Blower Assembly	
♦ Exploded View	6	♦ Exploded View	17
♦ Usage List	7	♦ Usage List	17
♦ Usage List	8		
Functional Components – Standard & Dehum.		General Notes	
♦ Exploded View	10	➤ Revised and/or additional pages may be issued from time to time.	
♦ Usage List	11	➤ A complete and current manual consists of pages shown in the following contents section.	
♦ Usage List	12		
EEV Controller Assembly		Important	
♦ Exploded View	13	➤ Contact the installing and/or local Bard distributor for all parts requirements. Make sure to have the complete model and serial number available from the unit rating plates.	
♦ Usage List	13		



Bard Manufacturing Company, Inc.
Bryan, Ohio 43506
www.bardhvac.com

Manual: 2110-1452I
Supersedes: 2110-1452H
Date: 1-12-22

EXTERNAL PARTS – STANDARD & DEHUMIDIFICATION

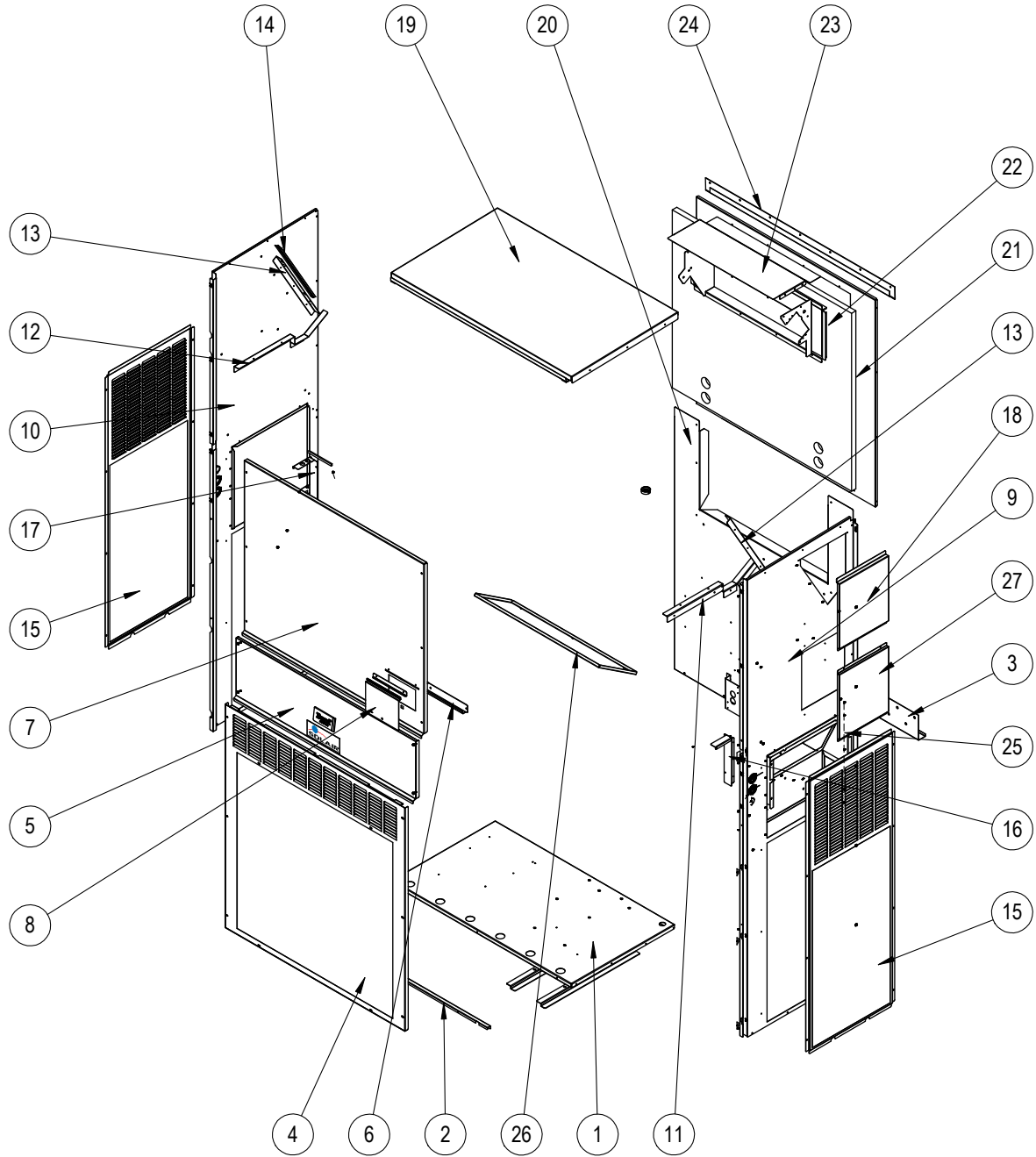

SEXP-932 B

This drawing to be used for reference for pages 3 and 4

EXTERNAL PARTS – STANDARD & DEHUMIDIFICATION

Dwg No.	Part Number	Description	W42AC-A, B, C, E, F, RC	W42ACDA, B, C	W48AC-A, B, C, E, F, RC	W48ACDA, B, C
1	S127-574	Unit Base	X	X	X	X
1	S127-584 ③	Unit Base	0	0	0	0
2	113-762	Front Base Bracket	X	X	X	X
2	113-797 ③	Front Base Bracket	0	0	0	0
3	113-140	Bottom Mounting Bracket	X	X	X	X
4	119-125-* ①	Front Grille	X	X	X	X
4	119-148 ②	Front Grille	0	0	0	0
4	119-135 ③	Front Grille	0	0	0	0
5	S533-301-* ①	Control Panel Cover (Outer)	X	X	X	X
5	S533-309 ②	Control Panel Cover (Outer)	0	0	0	0
5	S533-310 ③	Control Panel Cover (Outer)	0	0	0	0
6	S165-608-* ①	Rain Channel	X	X	X	X
6	S165-609 ②	Rain Channel	0	0	0	0
6	S165-610 ③	Rain Channel	0	0	0	0
7	S515-323-* ①	Upper Front	X	X	X	X
7	S515-328 ②	Upper Front	0	0	0	0
7	S515-330 ③	Upper Front	0	0	0	0
8	153-717-* ①	Disconnect Access Door	X	X	X	X
8	153-723 ②	Disconnect Access Door	0	0	0	0
8	153-724 ③	Disconnect Access Door	0	0	0	0
9	S501-1127-* ①	Right Side	X	X	X	X
9	S501-1128 ②	Right Side	0	0	0	0
9	S501-1129 ③	Right Side	0	0	0	0
10	501-1054-* ①	Left Side	X	X	X	X
10	501-1073 ②	Left Side	0	0	0	0
10	501-1077 ③	Left Side	0	0	0	0
11	105X1454	Right Support Angle	X	X	X	X
12	105Y1454	Left Support Angle	X	X	X	X
13	105-1457	Coil Support	2	2	2	2
14	147-055	Coil Support Offset	X	X	X	X
15	119-126-* ①	Side Grille	2	2	2	2
15	119-142 ②	Side Grille	2	2	2	2
15	119-136 ③	Side Grille	2	2	2	2
16	105-1450	Right Control Panel Angle	X	X	X	X
17	105-1451	Left Control Panel Angle	X	X	X	X
18	S543-221-* ①	Heater Access Cover	X	X	X	X
18	S543-228 ②	Heater Access Cover	0	0	0	0
18	S543-229 ③	Heater Access Cover	0	0	0	0
19	507-382-* ①	Top	X	X	X	X
19	507-391 ②	Top	0	0	0	0
19	507-392 ③	Top	0	0	0	0
20	109-412	Lower Back	X	X	X	X
20	109-418 ②	Lower Back	0	0	0	0
20	109-422 ③	Lower Back	0	0	0	0
21	S509-411	Upper Back	X	X	X	X
21	S509-417 ②	Upper Back	0	0	0	0
21	S509-421 ③	Upper Back	0	0	0	0
22	S111-299	Outlet Air Frame Assembly	X	X	X	X
23	535-129	Heat Shield	X	X	X	X
24	113-150-* ①	Top Rain Flashing	X	X	X	X
24	113-150-4 ②	Top Rain Flashing	0	0	0	0
24	113-359 ③	Top Rain Flashing	0	0	0	0
25	539-406	Fresh Air Damper Assembly	X	X	X	X
25	543-222	Intake Blank Off Plate	0	0	0	0
26	543-220	Exhaust Blank Off Plate	X	X	X	X
27	S543-248-* ①	Access Cover	X	X	X	X
27	S543-250 ②	Access Cover	0	0	0	0
27	S543-251 ③	Access Cover	0	0	0	0
NS	5252-033	Bard Nameplate	X	X	X	X

① Exterior cabinet parts are manufactured with various paint color options. To ensure the proper paint color is received, include the complete model and serial number of the unit for which cabinet parts are being ordered.

X – Standard Component
0 – Optional Component

② Exterior cabinet parts are manufactured from aluminum Code "A". #24 - Top rain flashing not available in aluminum; order 113-150-4 (Buckeye Gray).

③ Exterior cabinet parts are manufactured from stainless steel Code "S"

EXTERNAL PARTS – STANDARD & DEHUMIDIFICATION

Dwg No.	Part Number	Description	W60AC-A, B, C, E, F, RC	W60ACDA, B, C	W72AC-A, B, C, F, RC	W72ACDA, B, C
1	S127-574	Unit Base	X	X	X	X
1	S127-584 ③	Unit Base	0	0	0	0
2	113-762	Front Base Bracket	X	X	X	X
2	113-797 ③	Front Base Bracket	0	0	0	0
3	113-140	Bottom Mounting Bracket	X	X	X	X
4	119-127-* ①	Front Grille	X	X	X	X
4	119-149 ②	Front Grille	0	0	0	0
4	119-137 ③	Front Grille	0	0	0	0
5	S533-301-* ①	Control Panel Cover (Outer)	X	X	X	X
5	S533-309 ②	Control Panel Cover (Outer)	0	0	0	0
5	S533-310 ③	Control Panel Cover (Outer)	0	0	0	0
6	S165-608-* ①	Rain Channel	X	X	X	X
6	S165-609 ②	Rain Channel	0	0	0	0
6	S165-610 ③	Rain Channel	0	0	0	0
7	S515-324-* ①	Upper Front	X	X	X	X
7	S515-329 ②	Upper Front	0	0	0	0
7	S515-331 ③	Upper Front	0	0	0	0
8	153-717-* ①	Disconnect Access Door	X	X	X	X
8	153-723 ②	Disconnect Access Door	0	0	0	0
8	153-724 ③	Disconnect Access Door	0	0	0	0
9	S501-1130-* ①	Right Side	X	X	X	X
9	S501-1131 ②	Right Side	0	0	0	0
9	S501-1132 ③	Right Side	0	0	0	0
10	501-1056-* ①	Left Side	X	X	X	X
10	501-1075 ②	Left Side	0	0	0	0
10	501-1079 ③	Left Side	0	0	0	0
11	105X1454	Right Support Angle	X	X	X	X
12	105Y1454	Left Support Angle	X	X	X	X
13	105-1455	Coil Support	2	2	2	2
14	147-054	Coil Support Offset	X	X	X	X
15	119-128-* ①	Side Grille	2	2	2	2
15	119-143 ②	Side Grille	2	2	2	2
15	119-138 ③	Side Grille	2	2	2	2
16	105-1450	Right Control Panel Angle	X	X	X	X
17	105-1451	Left Control Panel Angle	X	X	X	X
18	S543-221-* ①	Heater Access Cover	X	X	X	X
18	S543-228 ②	Heater Access Cover	0	0	0	0
18	S543-229 ③	Heater Access Cover	0	0	0	0
19	507-382-* ①	Top	X	X	X	X
19	507-391 ②	Top	0	0	0	0
19	507-392 ③	Top	0	0	0	0
20	109-414	Lower Back	X	X	X	X
20	109-420 ②	Lower Back	0	0	0	0
20	109-424 ③	Lower Back	0	0	0	0
21	S509-413	Upper Back	X	X	X	X
21	S509-419 ②	Upper Back	0	0	0	0
21	S509-423 ③	Upper Back	0	0	0	0
22	S111-299	Outlet Air Frame Assembly	X	X	X	X
23	535-129	Heat Shield	X	X	X	X
24	113-150-* ①	Top Rain Flashing	X	X	X	X
24	113-150-4 ②	Top Rain Flashing	0	0	0	0
24	113-359 ③	Top Rain Flashing	0	0	0	0
25	539-406	Fresh Air Damper Assembly	X	X	X	X
25	543-222	Intake Blank Off Plate	0	0	0	0
26	543-220	Exhaust Blank Off Plate	X	X	X	X
27	S543-248-* ①	Access Cover	X	X	X	X
27	S543-250 ②	Access Cover	0	0	0	0
27	S543-251 ③	Access Cover	0	0	0	0
NS	5252-033	Bard Nameplate	X	X	X	X

① Exterior cabinet parts are manufactured with various paint color options. To ensure the proper paint color is received, include the complete model and serial number of the unit for which cabinet parts are being ordered.

X – Standard Component
O – Optional Component

This page intentionally left blank

INTERNAL PARTS – STANDARD & DEHUMIDIFICATION

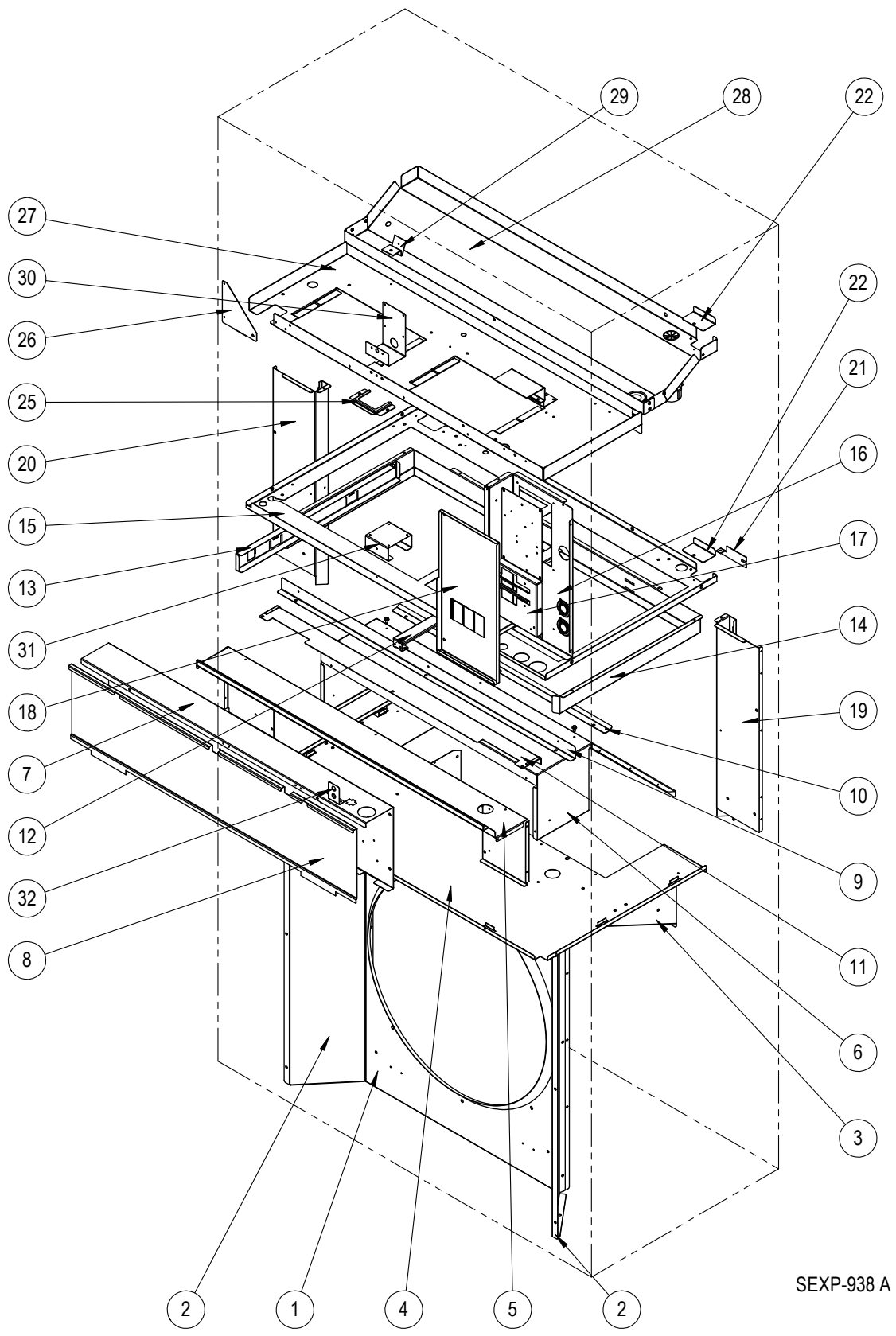

SEXP-938 A

This drawing to be used for reference for pages 7 and 8

INTERNAL PARTS – STANDARD & DEHUMIDIFICATION

Dwg No.	Part Number	Description	W42AC-A, B, E	W42AC-C, F, RC	W42ACDA, B	W42ACDC	W48AC-A, B, E	W48AC-C, F, RC	W48ACDA, B	W48ACDC
1	125-089	Fan Shroud	X	X	X	X	X	X	X	X
1	125-093 ①	Fan Shroud	0	0	0	0	0	0	0	0
2	S125-090	Fan Shroud Side Access Cover	2	2	2	2	2	2	2	2
2	S125-094 ①	Fan Shroud Side Access Cover	2	2	2	2	2	2	2	2
3	121-586	Condenser Partition Insert	X	X	X	X	X	X	X	X
3	121-600 ①	Condenser Partition Insert	0	0	0	0	0	0	0	0
4	121-585	Condenser Partition	X	X	X	X	X	X	X	X
4	121-599 ①	Condenser Partition	0	0	0	0	0	0	0	0
5	521-630	Front Exhaust Partition	X	X	X	X	X	X	X	X
6	521-587	Exhaust Partition	X	X	X	X	X	X	X	X
7	Control Panel Assy.	See Control Panel Assy. Drawing & Parts List	X	X	X	X	X	X	X	X
8	S133-330	Control Panel Cover (Inner)	X	X	X	X	X	X	X	X
9	105-1453	Front Vent Guide Rail	X	X	X	X	X	X	X	X
10	105-1452	Vent Guide Rail	X	X	X	X	X	X	X	X
11	S135-409	Field Wire Shield	X	X	X	X	X	X	X	X
12	131-168	Filter Support Bracket	2	2	2	2	2	2	2	2
13	131-170	Filter Slide	X	X	X	X	X	X	X	X
14	131-169	Filter Rack Frame	X	X	X	X	X	X	X	X
15	121-583	Filter Partition	X	X	X	X	X	X	X	X
16	117-412	Upper Control Panel	X	X	X	X	X	X	X	X
17	127-575	Circuit Breaker Base	X		X		X		X	
17	127-585	Circuit Breaker Base - 460V		X		X		X		X
18	S133-303	Upper Control Panel Cover	X		X		X		X	
18	S133-304	Upper Control Panel Cover - 460V		X		X		X		X
19	135X393	Right Copper Chase	X	X	X	X	X	X	X	X
19	135X397 ①	Right Copper Chase	0	0	0	0	0	0	0	0
20	135Y393	Left Copper Chase	X	X	X	X	X	X	X	X
20	135Y397 ①	Left Copper Chase	0	0	0	0	0	0	0	0
21	113-796	Copper Retainer	2	2	2	2	2	2	2	2
22	137-920	Copper Fill Plate	2	2	2	2	2	2	2	2
25	113-765	Grommet Retainer	X	X	X	X	X	X	X	X
26	141-492	Blower Partition Support	X	X	X	X	X	X	X	X
27	121-582	Blower Partition	X	X	X	X	X	X	X	X
28	523-161	Drain Pan	X	X	X	X	X	X	X	X
28	523-162 ①②	Drain Pan	0	0	0	0	0	0	0	0
29	113-768	EEV mounting Bracket			X	X			X	X
30	113-787	Airflow Switch Bracket	0	0	0	0	0	0	0	0
31	113-788	Filter Switch Bracket	0	0	0	0	0	0	0	0
32	113-789	Filter Switch Light Bracket	0	0	0	0	0	0	0	0

- ① Internal parts are manufactured from stainless steel Code "S"
 ② For aluminum units, order 523-162 stainless steel drain pan.

X – Standard Component
 0 – Optional Component

INTERNAL PARTS – STANDARD & DEHUMIDIFICATION

Dwg No.	Part Number	Description	W60AC-A, B, E	W60AC-C, F, RC	W60ACDA, B	W60ACDC	W72AC-A, B	W72AC-C, F, RC	W72ACDA, B	W72ACDC
1	125-091	Fan Shroud	X	X	X	X	X	X	X	X
1	125-095 ①	Fan Shroud	0	0	0	0	0	0	0	0
2	S125-092	Fan Shroud Side Access Cover	2	2	2	2	2	2	2	2
2	S125-096 ①	Fan Shroud Side Access Cover	2	2	2	2	2	2	2	2
3	121-586	Condenser Partition Insert	X	X	X	X	X	X	X	X
3	121-600 ①	Condenser Partition Insert	0	0	0	0	0	0	0	0
4	121-585	Condenser Partition	X	X	X	X	X	X	X	X
4	121-599 ①	Condenser Partition	0	0	0	0	0	0	0	0
5	521-630	Front Exhaust Partition	X	X	X	X	X	X	X	X
6	521-587	Exhaust Partition	X	X	X	X	X	X	X	X
7	Control Panel Assy.	See Control Panel Assy. Drawing & Parts List	X	X	X	X	X	X	X	X
8	S133-330	Control Panel Cover (Inner)	X	X	X	X	X	X	X	X
9	105-1453	Front Vent Guide Rail	X	X	X	X	X	X	X	X
10	105-1452	Vent Guide Rail	X	X	X	X	X	X	X	X
11	S135-409	Field Wire Shield	X	X	X	X	X	X	X	X
12	131-168	Filter Support Bracket	2	2	2	2	2	2	2	2
13	131-170	Filter Slide	X	X	X	X	X	X	X	X
14	131-169	Filter Rack Frame	X	X	X	X	X	X	X	X
15	121-583	Filter Partition	X	X	X	X	X	X	X	X
16	117-412	Upper Control Panel	X	X	X	X	X	X	X	X
17	127-575	Circuit Breaker Base	X		X		X		X	
17	127-585	Circuit Breaker Base - 460V		X		X		X		X
18	S133-303	Upper Control Panel Cover	X		X		X		X	
18	S133-304	Upper Control Panel Cover - 460V		X		X		X		X
19	135X393	Right Copper Chase	X	X	X	X	X	X	X	X
19	135X397 ①	Right Copper Chase	0	0	0	0	0	0	0	0
20	135Y393	Left Copper Chase	X	X	X	X	X	X	X	X
20	135Y397 ①	Left Copper Chase	0	0	0	0	0	0	0	0
21	113-796	Copper Retainer	2	2	2	2	2	2	2	2
22	137-920	Copper Fill Plate	2	2	2	2	2	2	2	2
25	113-765	Grommet Retainer	X	X	X	X	X	X	X	X
26	141-492	Blower Partition Support	X	X	X	X	X	X	X	X
27	121-582	Blower Partition	X	X	X	X	X	X	X	X
28	523-161	Drain Pan	X	X	X	X	X	X	X	X
28	523-162 ①②	Drain Pan	0	0	0	0	0	0	0	0
29	113-768	EEV mounting Bracket			X	X			X	X
30	113-787	Airflow Switch Bracket	0	0	0	0	0	0	0	0
31	113-788	Filter Switch Bracket	0	0	0	0	0	0	0	0
32	113-789	Filter Switch Light Bracket	0	0	0	0	0	0	0	0

- ① Internal parts are manufactured from stainless steel Code "S"
 ② For aluminum units, order 523-162 stainless steel drain pan.

- X – Standard Component
 0 – Optional Component

Refer to drawing on page 6

This page intentionally left blank

FUNCTIONAL COMPONENTS – STANDARD & DEHUMIDIFICATION

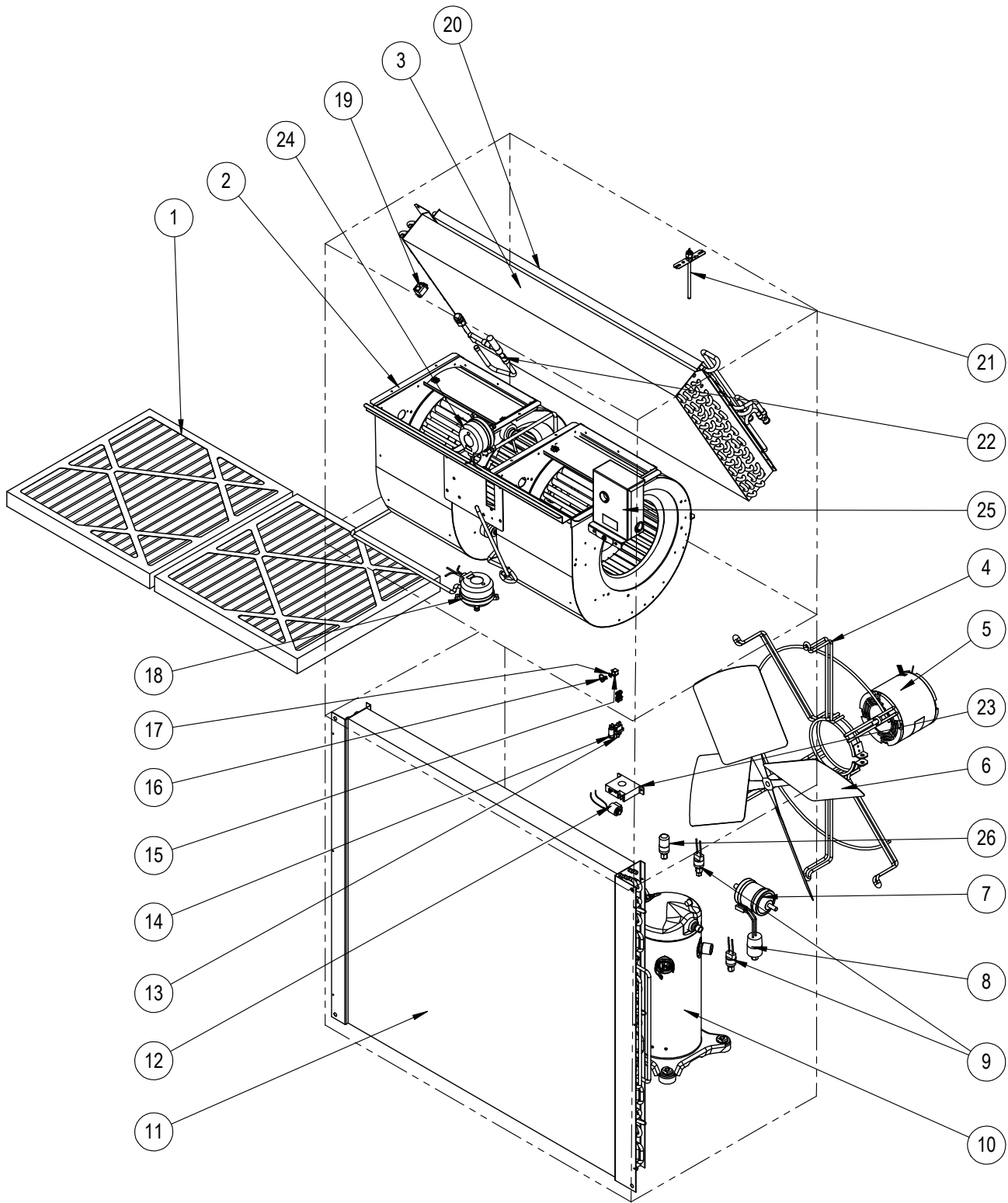

SEXP-931

This drawing to be used for reference for pages 11 and 12

EEV CONTROLLER ASSEMBLY

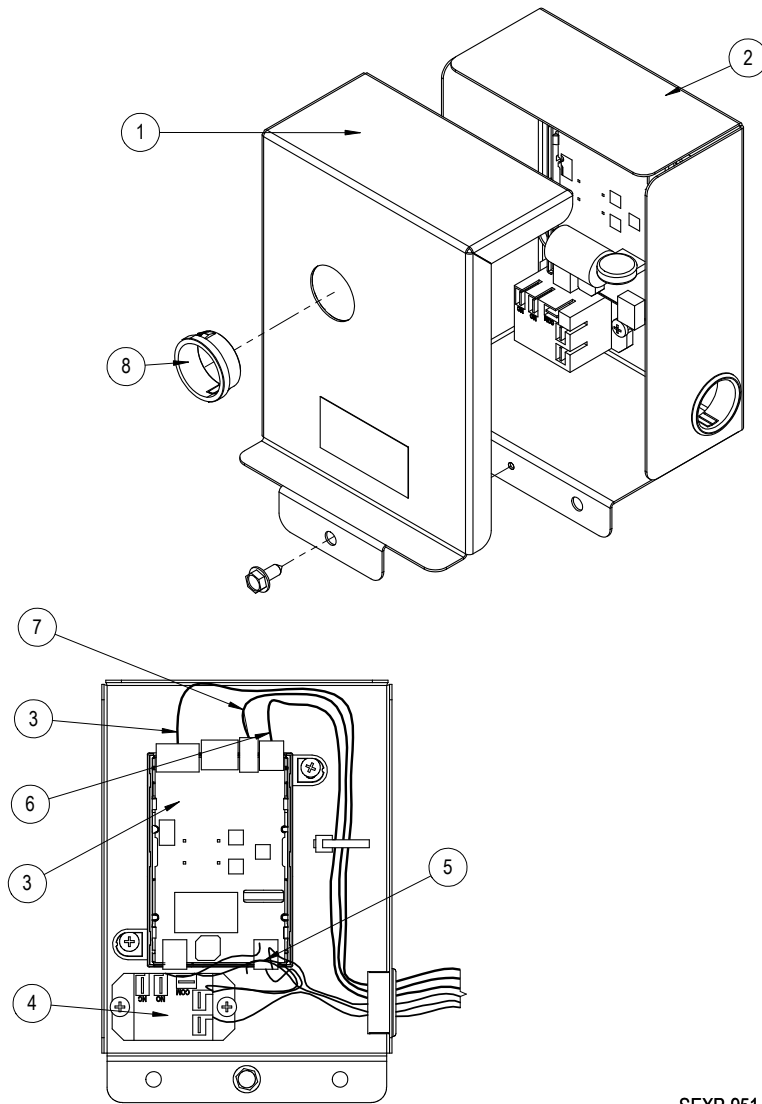

SEXP-951

S910-2050-001

Dwg No.	Part Number	Description	
1	143-219	EEV Control Box Cover	X
2	127-572	EEV Control Box	X
3	S8301-079-0001	EEV Control Module & Stator Cable	X
3	5651-246	EEV Stator Cable Only	X
4	8201-130	Control Relay	X
5	3000-1602	Main Wire Assembly	X
6	3000-1611	Transducer Wire Assembly – Connects to EEV Board	X
NS	3000-1603	Transducer Wire Assembly – Connects to Transducer	
7	8408-056	EEV Thermistor	X
8	8611-075	Clear Snap Plug	X

CONTROL PANEL – STANDARD & DEHUMIDIFICATION

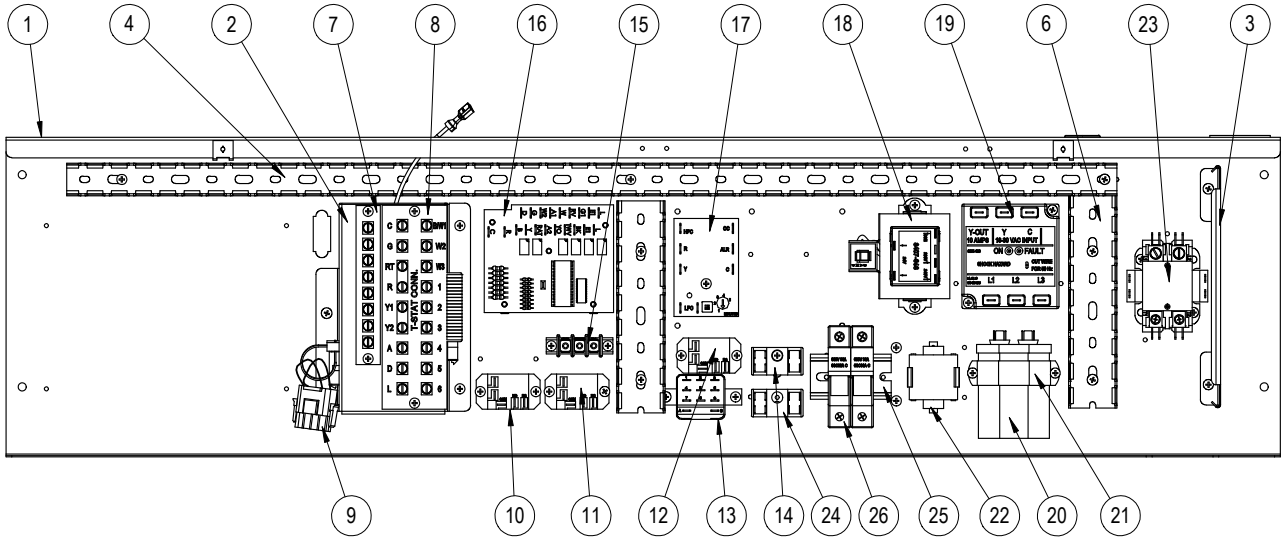

SEXP-928 B

This drawing to be used for reference for pages 15 and 16

CONTROL PANEL – STANDARD & DEHUMIDIFICATION

Dwg No.	Part Number	Description	W42AC-A	W42AC-B	W42AC-C	W42ACRC	W42AC-E	W42AC-F	W42ACDA	W42ACDB	W42ACDC	W48AC-A	W48AC-B	W48AC-C	W48ACRC	W48AC-E	W48AC-F	W48ACDA	W48ACDB	W48ACDC	
1	117-411	Control Panel	X	X	X	X	X	X	X	X	X	X	X	X	X	X	X	X	X	X	X
2	S910-2061	Complete Low Voltage Box Assembly (Sheet metal, Terminal Strip, & Wire Harness)	X	X	X	X	X	X	X	X	X	X	X	X	X	X	X	X	X	X	X
3	135-394	Wire Shield	X	X	X	X	X	X	X	X	X	X	X	X	X	X	X	X	X	X	X
4	8611-140-3208	Cable Duct - 32.5"	X	X	X	X	X	X	X	X	X	X	X	X	X	X	X	X	X	X	X
6	8611-244-0608	Cable Duct - 6.5" x 1.5" wide	2	2	2	2	2	2	2	2	2	2	2	2	2	2	2	2	2	2	2
7	8607-021	Low Voltage Terminal Strip - 8 term.	0	0	0	0	0	0	0	0	0	0	0	0	0	0	0	0	0	0	0
8	8607-063	Low Voltage Terminal Strip - 18 term.	X	X	X	X	X	X	X	X	X	X	X	X	X	X	X	X	X	X	X
9	3000-1524	Vent Jumper Plug (used when no vent option)	X	X	X	X	X	X	X	X	X	X	X	X	X	X	X	X	X	X	X
10	8201-130	Alarm Relay (Kit = CMC-35)	0	0	0	0	0	0	0	0	0	0	0	0	0	0	0	0	0	0	0
11	8201-130	Blower Speed Relay	X	X	X	X	X	X	X	X	X	X	X	X	X	X	X	X	X	X	X
12	8201-130	Dehumidification Control Relay							X	X	X								X	X	X
13	8201-159	Dirty Filter Relay (Kit = CMC-33)	0	0	0	0	0	0	0	0	0	0	0	0	0	0	0	0	0	0	0
14	8607-017	Terminal Block (LAC Kit = CMA-39)	0	0	0	0	0	0	0	0	0	0	0	0	0	0	0	0	0	0	0
15	8607-042	Blower Speed Terminal Block	X	X	X	X	X	X	X	X	X	X	X	X	X	X	X	X	X	X	X
16	8201-113	Dehumidification Logic Board							X	X	X								X	X	X
17	S8201-169	Compressor Control Module	X	X	X	X	X	X	X	X	X	X	X	X	X	X	X	X	X	X	X
18	8407-068	Transformer	X	X			X	X	X	X		X	X			X	X	X	X		
18	8407-069	Transformer			X	X					X			X	X						X
19	8201-126	Phase Monitor		X	X	X	X	X		X	X		X	X	X	X	X		X	X	
20	8552-079	Compressor Capacitor	X						X												
20	8552-089	Compressor Capacitor		X			X	X		X		X							X		
20	8552-005	Outdoor Motor Capacitor		X		X				X		X		X	X	X	X		X		
20	8552-004	Outdoor Motor Capacitor			X	X				X			X	X	X	X	X			X	X
21	8550-008	Capacitor Strap	X						X			X							X		
21	8550-003	Capacitor Strap		X	X	X	X	X		X	X		X	X	X	X	X		X	X	
22	8551-004	Start Device (PTCR) (Kit = CMC-32)	0						0			0							0		
23	8401-034	Compressor Contactor	X						X			X							X		
23	8401-035	Compressor Contactor		X	X	X	X	X		X	X		X	X	X	X	X		X	X	
24	8607-017	Terminal Block				X									X						
25	8611-210	DIN Rail				X									X						
26	8614-058	Fuse Block				X									X						
26	8614-046	5A Fuse													2						
26	8614-047	3.2A Fuse				2															
NS	8615-040	Circuit Breaker 50A 2 Pole ①	0						0			0							0		
NS	8615-042	Circuit Breaker 35A 3 Pole ①		0						0			0							0	
NS	8615-052	Circuit Breaker 30A 3 Pole ①				0					0				0						0
NS	S8615-067	Toggle Disconnect			0	0		0			0			0	0		0				0
NS	4095-196	Wiring Diagram	X							X		X									
NS	4095-198	Wiring Diagram		X			X		X				X					X			
NS	4095-296	Wiring Diagram								X						X			X		
NS	4095-297	Wiring Diagram									X								X		
NS	4095-378	Wiring Diagram			X								X							X	
NS	4095-379	Wiring Diagram									X										X
NS	4095-382	Wiring Diagram				X									X						
NS	4095-640	Wiring Diagram					X										X				
NS	3000-1613	Blower Power Plug	X	X	X	X	X		X	X	X	X	X	X	X	X		X	X	X	
NS	3000-1645	Blower Power Plug						X									X				
NS	3000-1614	Blower Speed Plug	X	X	X	X	X	X	X	X	X	X	X	X	X	X	X	X	X	X	X
NS	3000-1222	Compressor Plug/Harness	X						X			X							X		
NS	3000-1230	Compressor Plug/Harness		X	X	X	X	X		X	X	X	X	X	X	X	X		X	X	
NS	3003-053	Control Panel Wire Harness	X									X									
NS	3003-054	Control Panel Wire Harness								X	X								X	X	
NS	3003-055	Control Panel Wire Harness		X	X	X	X					X	X	X	X						
NS	3003-056	Control Panel Wire Harness						X									X				
NS	3003-057	Control Panel Wire Harness							X									X			
NS	3000-1608	Low Voltage Terminal Block Wire Harness	X	X	X	X	X	X	X	X	X	X	X	X	X	X	X	X	X	X	X

NS = Not Shown

① Circuit breakers listed are for units without electric heat, "0Z" models. See heater replacement parts manual for units with electric heat.

X – Standard Component
O – Optional Component

Manual 2110-14521
Page 15 of 17

CONTROL PANEL – STANDARD & DEHUMIDIFICATION

Dwg No.	Part Number	Description	W60AC-A	W60AC-B	W60AC-C	W60ACRC	W60AC-E	W60AC-F	W60ACDA	W60ACDB	W60ACDC	W72AC-A	W72AC-B	W72AC-C	W72ACRC	W72AC-F	W72ACDA	W72ACDB	W72ACDC
1	117-411	Control Panel	X	X	X	X	X	X	X	X	X	X	X	X	X	X	X	X	X
2	S910-2061	Complete Low Voltage Box Assembly (Sheet metal, Terminal Strip, & Wire Harness)	X	X	X	X	X	X	X	X	X	X	X	X	X	X	X	X	X
3	135-394	Wire Shield	X	X	X	X	X	X	X	X	X	X	X	X	X	X	X	X	X
4	8611-140-3208	Cable Duct - 32.5"	X	X	X	X	X	X	X	X	X	X	X	X	X	X	X	X	X
6	8611-244-0608	Cable Duct - 6.5" x 1.5" wide	2	2	2	2	2	2	2	2	2	2	2	2	2	2	2	2	2
7	8607-021	Low Voltage Terminal Strip - 8 term.	0	0	0	0	0	0	0	0	0	0	0	0	0	0	0	0	0
8	8607-063	Low Voltage Terminal Strip - 18 term.	X	X	X	X	X	X	X	X	X	X	X	X	X	X	X	X	X
9	3000-1524	Vent Jumper Plug (used when no vent option)	X	X	X	X	X	X	X	X	X	X	X	X	X	X	X	X	X
10	8201-130	Alarm Relay (Kit = CMC-35)	0	0	0	0	0	0	0	0	0	0	0	0	0	0	0	0	0
11	8201-130	Blower Speed Relay	X	X	X	X	X	X	X	X	X	X	X	X	X	X	X	X	X
12	8201-130	Dehumidification Control Relay							X	X	X						X	X	X
13	8201-159	Dirty Filter Relay (Kit = CMC-33)	0	0	0	0	0	0	0	0	0	0	0	0	0	0	0	0	0
14	8607-017	Terminal Block (LAC Kit = CMA-39)	0	0	0	0	0	0	0	0	0	0	0	0	0	0	0	0	0
15	8607-042	Blower Speed Terminal Block	X	X	X	X	X	X	X	X	X	X	X	X	X	X	X	X	X
16	8201-113	Dehumidification Logic Board							X	X	X						X	X	X
17	S8201-169	Compressor Control Module	X	X	X	X	X	X	X	X	X	X	X	X	X	X	X	X	X
18	8407-068	Transformer	X	X			X	X	X			X	X			X	X	X	
18	8407-069	Transformer			X	X					X			X	X				X
19	8201-126	Phase Monitor		X	X	X	X	X		X	X		X	X	X	X		X	X
20	8552-089	Compressor Capacitor	X						X										
20	8552-097	Compressor Capacitor		X							X						X		
20	8552-005	Outdoor Motor Capacitor			X	X			X				X	X					X
20	8552-004	Outdoor Motor Capacitor			X	X				X			X		X		X		
21	8550-008	Capacitor Strap	X						X			X					X		
21	8550-003	Capacitor Strap		X	X	X	X	X		X	X		X	X	X	X		X	X
22	8551-004	Start Device (PTCR) (Kit = CMC-32)	0						0			0					0		
23	8401-034	Compressor Contactor	X						X			X					X		
23	8401-035	Compressor Contactor		X	X	X	X	X		X	X		X	X	X	X		X	X
24	8607-017	Terminal Block				X									X				
25	8611-210	DIN Rail				X									X				
26	8614-058	Fuse Block				X									X				
26	8614-046	5A Fuse				2									2				
NS	8615-041	Circuit Breaker 60A 2 Pole ①	0						0			0					0		
NS	8615-043	Circuit Breaker 40A 3 Pole ①		0						0									
NS	8615-045	Circuit Breaker 50A 3 Pole ①											0					0	
NS	S8615-067	Toggle Disconnect			0	0		0			0			0	0	0			0
NS	4095-196	Wiring Diagram	X						X			X					X		
NS	4095-198	Wiring Diagram		X			X						X						
NS	4095-296	Wiring Diagram							X								X		
NS	4095-297	Wiring Diagram			X					X								X	
NS	4095-378	Wiring Diagram									X			X					X
NS	4095-379	Wiring Diagram													X				
NS	4095-382	Wiring Diagram				X									X				
NS	4095-640	Wiring Diagram					X									X			
NS	3000-1613	Blower Power Plug	X	X	X	X	X	X	X	X	X	X	X	X	X		X	X	X
NS	3000-1645	Blower Power Plug						X								X			
NS	3000-1614	Blower Speed Plug	X	X	X	X	X	X	X	X	X	X	X	X	X	X	X	X	X
NS	3000-1222	Compressor Plug/Harness	X						X			X					X		
NS	3000-1230	Compressor Plug/Harness		X	X	X	X	X		X	X		X	X	X	X		X	X
NS	3003-053	Control Panel Wire Harness	X							X	X								
NS	3003-054	Control Panel Wire Harness								X	X							X	X
NS	3003-055	Control Panel Wire Harness		X	X	X	X					X	X	X					
NS	3003-056	Control Panel Wire Harness						X								X			
NS	3003-057	Control Panel Wire Harness							X								X		
NS	3000-1608	Low Voltage Terminal Block Wire Harness	X	X	X	X	X	X	X	X	X	X	X	X	X	X	X	X	X

① Circuit breakers listed are for units without electric heat, "0Z" models. NS = Not Shown X – Standard Component
See heater replacement parts manual for units with electric heat. O – Optional Component

BLOWER ASSEMBLY

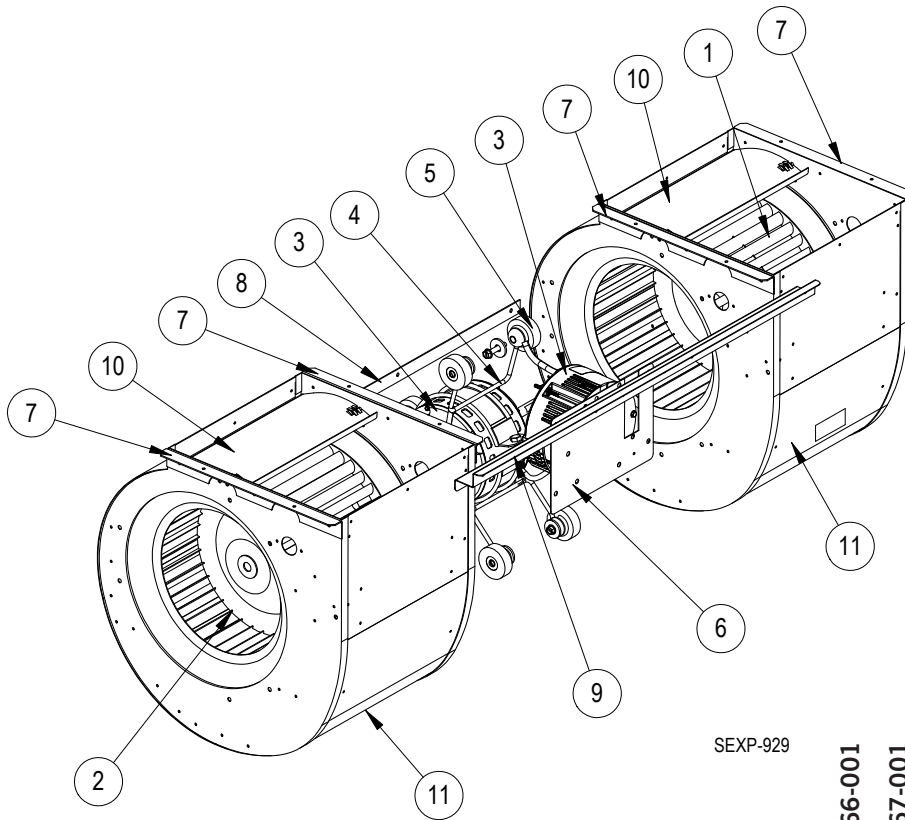

SEXP-929

Dwg No.	Part Number	Description	S900-366-001	S900-367-001	S900-368-001	S900-368-002	S900-368-003	S900-369-001	S900-369-002	S900-369-003
1	5152-011	10 Inch Wheel (CW)	X	X	X	X	X	X	X	X
2	5152-012	10 Inch Wheel (CW)	X	X	X	X	X	X	X	X
3	S8106-068-0155	Programmed Blower Motor & Control (230/208V)	X							
3	S8106-069-0156	Programmed Blower Motor & Control (460V)		X						
3	S8107-028-0157	Programmed Blower Motor & Control (230/208V)			X					
3	S8107-028-0159	Programmed Blower Motor & Control (230/208V)				X				
3	S8107-028-0161	Programmed Blower Motor & Control (230/208V)					X			
3	S8107-029-0158	Programmed Blower Motor & Control (460V)						X		
3	S8107-029-0160	Programmed Blower Motor & Control (460V)							X	
3	S8107-029-0162	Programmed Blower Motor & Control (460V)								X
3	C8106-068-0155	Programmed Control Only (230/208V)	0							
3	C8106-069-0156	Programmed Control Only (460V)		0						
3	C8107-028-0157	Programmed Control Only (230/208V)			0					
3	C8107-028-0159	Programmed Control Only (230/208V)				0				
3	C8107-028-0161	Programmed Control Only (230/208V)					0			
3	C8107-029-0158	Programmed Control Only (460V)						0		
3	C8107-029-0160	Programmed Control Only (460V)							0	
3	C8107-029-0162	Programmed Control Only (460V)								0
4	8200-040	Motor Mount	X	X	X	X	X	X	X	X
5	5451-011	Grommets	6	6	6	6	6	6	6	6
6	112-775	Motor Control Bracket	X	X	X	X	X	X	X	X
7	105-880	Side Angle	4	4	4	4	4	4	4	4
8	105-881	Back Brace	X	X	X	X	X	X	X	X
9	103-541	Front Mounting Offset	X	X	X	X	X	X	X	X
10	144-166	Diffuser	2	2	2	2	2	2	2	2
11	151-101	Blower Housing	2	2	2	2	2	2	2	2