

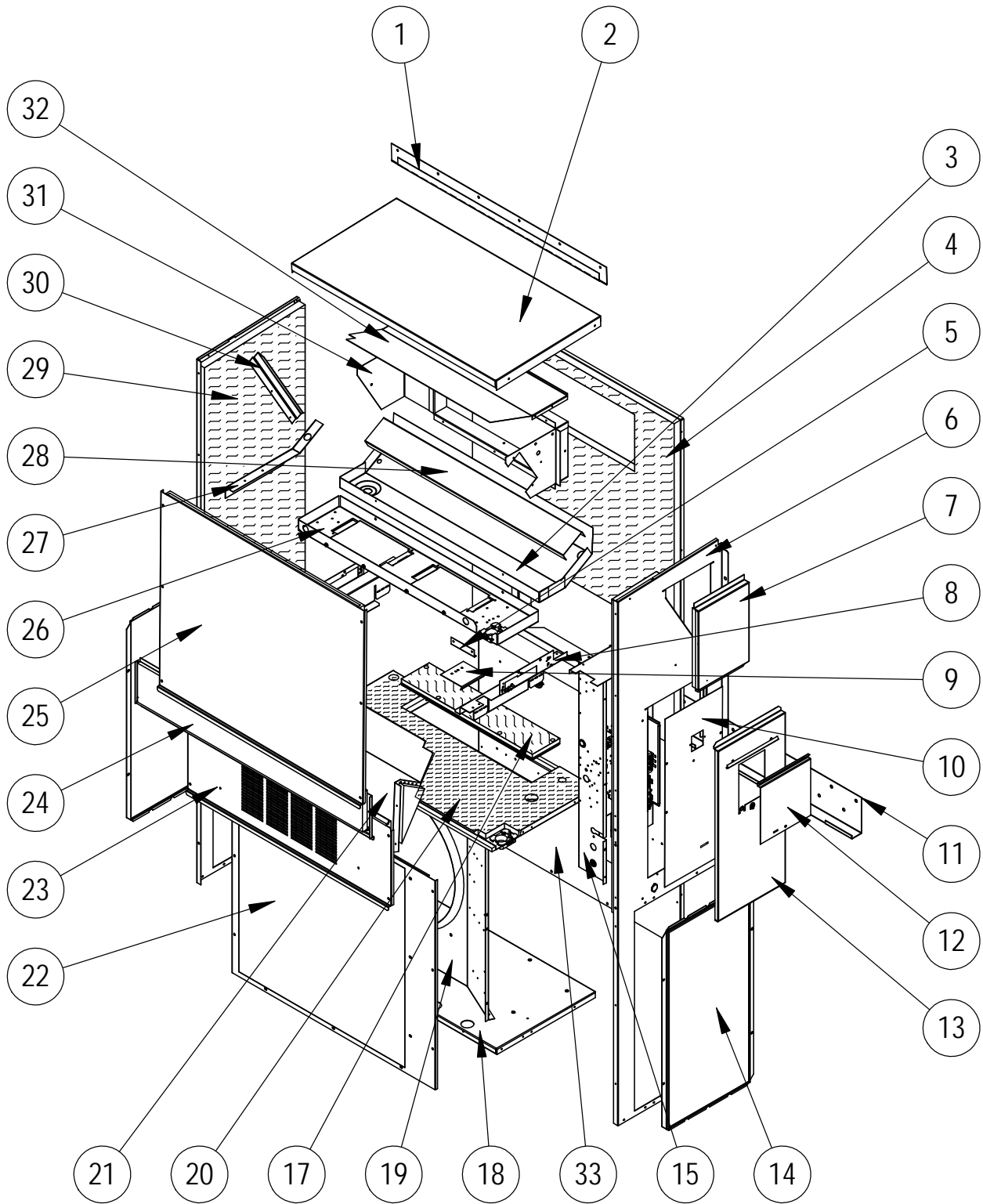

# CABINET COMPONENTS - RIGHT



SEXP-907 C

## CABINET COMPONENTS – RIGHT

Dwg No.	Part Number	Description	J18AB-A	J24AB-A, B	J24AB- C
1	113-141-X	Top Rain Flashing	X	X	X
2	S507-311-X	Top	X	X	X
3	S123-126	Drain Pan	X	X	X
4	S509-445	Upper Back	X	X	X
5	105-1302	Grommet Retainer	X	X	X
6	S501-933-X	Right Side	X	X	X
7	S543-175-X	Right Side Cover Plate (Outer)	X	X	X
8	113X480	Filter Bracket	2	2	2
9	137-259	Fill Plate	X	X	X
10	S132-104	Control Panel Cover (Inner)	X	X	
10	S132-172	Control Panel Cover (Inner)			X
11	113-140	Bottom Mounting Bracket	X	X	X
12	S153-218-X	Disconnect Access Door	X	X	X
13	S533-228-X	Control Panel Cover (Outer)	X	X	X
14	118-105-X	Side Grille	2	2	2
15	Control Panel Assembly	See Control Panel Assy. Drawing & Parts List Assy.	X	X	X
17	S536-176	Cond. Partition Block Off Plate	X	X	X
18	S127-467	Lower Base	X	X	X
19	125-080	Fan Shroud	X	X	X
20	S521X528	Condenser Partition	X	X	X
21	FAD-NE2	Fresh Air Damper Assembly	X	X	X
22	118-101-X	Condenser Grille	X	X	X
23	S553-537-X	Vent Option Door	X	X	X
24	S553-538-X	Filter Door	X	X	X
25	S514-263-X	Upper Front	X	X	X
26	121X480	Blower Partition	X	X	X
27	105X850	Side Support	X	X	X
28	137-694	Bottom Evaporator Fill	X	X	X
29	S501-934-X	Left Side	X	X	X
30	147-044	Evaporator Support	X	X	X
31	S111X032	Outlet Air Frame Assembly	X	X	X
32	135X127	Heat Shield	X	X	X
33	109-444	Lower Back	X	X	X
NS	5252-035	Solair Nameplate	X	X	X

NS – Not Shown

# CABINET COMPONENTS - LEFT

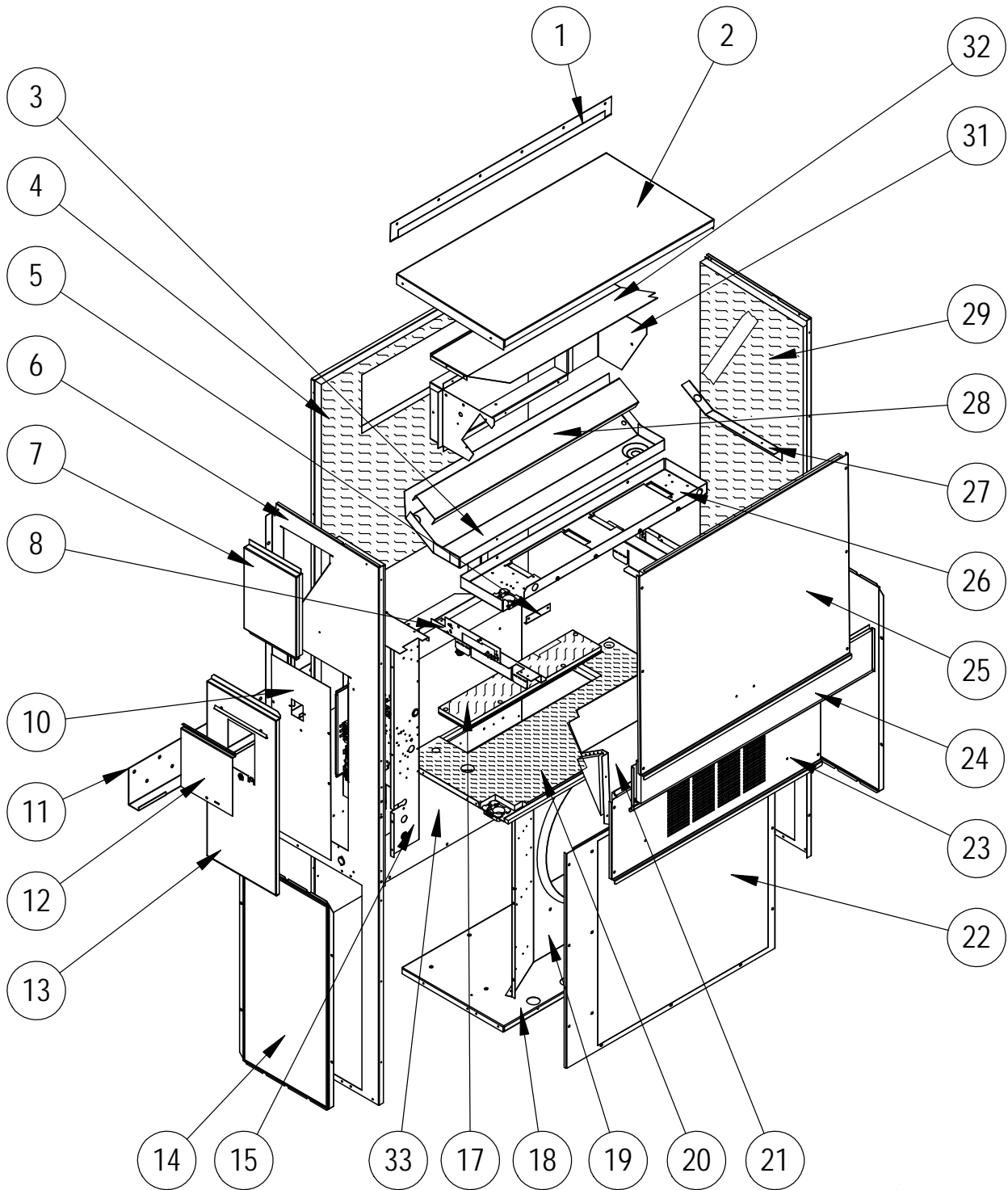

SEXP-946 B

## CABINET COMPONENTS – LEFT

Dwg No.	Part Number	Description	J18LB-A	J24LB-A, -B
1	113-141-X	Top Rain Flashing	X	X
2	S507-311-X	Top	X	X
3	S123-131	Drain Pan	X	X
4	S508-342	Back	X	X
5	105-1302	Grommet Retainer	X	X
6	S501-935-X	Right Side	X	X
7	S543-175-X	Right Side Cover Plate (Outer)	X	X
8	113Y480	Filter Bracket	2	2
9	137-259	Fill Plate	X	X
10	S132-104	Control Panel Cover (Inner)	X	X
11	113-140	Bottom Mounting Bracket	X	X
12	S153-218-X	Disconnect Access Door	X	X
13	S533-228-X	Control Panel Cover (Outer)	X	X
14	118-105-X	Side Grille	2	2
15	Control Panel Assembly	See Control Panel Assy. Drawing & Parts List Assy.	X	X
17	S536-176	Cond. Partition Block Off Plate	X	X
18	127-468	Lower Base	X	X
19	125-080	Fan Shroud	X	X
20	S521Y528	Condenser Partition	X	X
21	FAD-NE2	Fresh Air Damper Assembly	X	X
22	118-102-X	Condenser Grille	X	X
23	S553-537-X	Vent Option Door	X	X
24	S553-538-X	Filter Door	X	X
25	S514-263-X	Upper Front	X	X
26	121Y480	Blower Partition	X	X
27	105Y850	Side Support	X	X
28	137-694	Bottom Evaporator Fill	X	X
29	S501-936-X	Left Side	X	X
30	147-044	Evaporator Support	X	X
31	S111Y032	Outlet Air Frame Assembly	X	X
32	135Y127	Heat Shield	X	X
NS	5252-035	Solair Namplate	X	X

NS – Not Shown

# FUNCTIONAL COMPONENTS - RIGHT

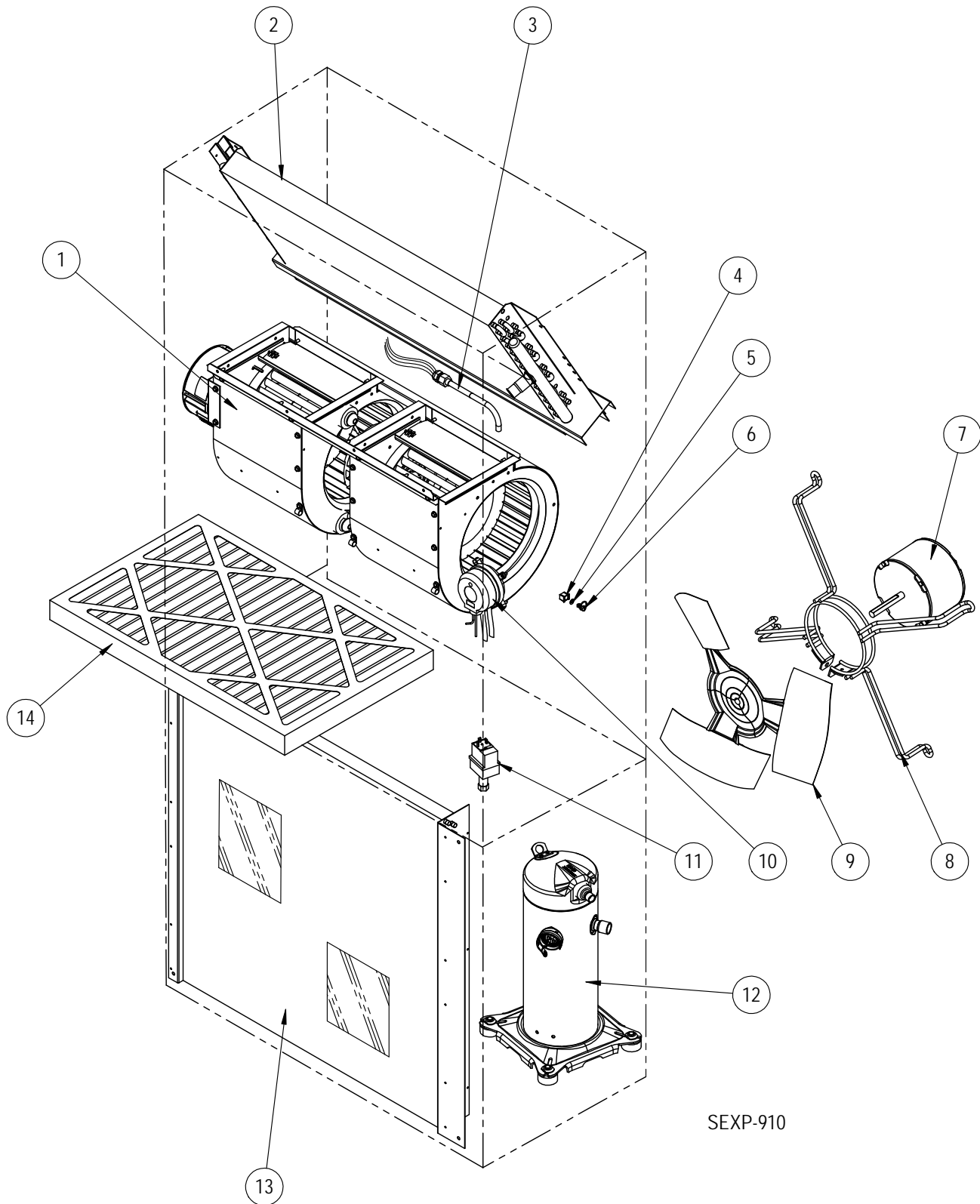

SEXP-910

## FUNCTIONAL COMPONENTS – RIGHT

Dwg No.	Part Number	Description	J18AB-A	J24AB-A	J24AB-B	J24AB-C
1	S900-358-002	Blower Assembly		X	X	
1	S900-359-001	Blower Assembly				X
1	S900-358-001	Blower Assembly	X			
2	917-0381BX	Evaporator Coil with Distributor Assembly	X			
2	917-0353BX	Evaporator Coil with Distributor Assembly		X	X	X
3	800-0458	Distributor Assembly	X			
3	800-0481	Distributor Assembly		X	X	X
4	1171-023	1/4" Receptacle	X	X	X	X
5	1171-024	1/4" Turn Retainer	X	X	X	X
6	1171-022	1/4" Turn Fastener	X	X	X	X
7	8103-028	Condenser Motor	X	X	X	
7	8103-030	Condenser Motor				X
8	8200-001	Fan Motor Mount	X	X	X	X
9	5151-033	Fan Blade	X	X	X	
9	5151-046	Fan Blade				X
10	CMC-31	Dirty Filter Switch Kit	X	X	X	X
11	CMA-37	Modulating Low Ambient Control (Screw On) ①	0	0	0	
11	CMA-38	460V Modulating Low Ambient Control ①				0
12	8000-433	Compressor	X			
12	8000-434	Compressor		X		
12	8000-435	Compressor			X	
12	8000-436	Compressor				X
13	5051-205BX	Condenser Coil	X			
13	5051-204BX	Condenser Coil		X	X	X
14	7004-025	Air Filter 2" Pleated (16x25x2)	X	X	X	X
14	7004-011	Air Filter 1" Throw-Away ① (16x25x1)	0	0	0	0
14	7003-032	Air Filter 1" Washable ① (16x25x1)	0	0	0	0
14	7004-059	Air Filter 2" Pleated – MERV 11 ① (16x25x2)	0	0	0	0
14	7004-061	Air Filter 2" Pleated – MERV 13 ① (16x25x2)	0	0	0	0
NS	8406-142	High Pressure Switch (Screw On)	X	X	X	X
NS	8406-140	Low Pressure Switch (Screw On)	X	X	X	X
NS	5201-021	Filter Drier	X	X	X	X
NS	5451-024	Tubing Isolation Grommet	X	X	X	X
NS	6031-009	Coremax Valve Core	X	X	X	X
NS	1171-028	Filter Door Clip	2	2	2	2
NS	1171-057	Filter Door Screw	2	2	2	2
NS	1171-027	Filter Door Screw Retainer	2	2	2	2

NS – Not Shown

① – Optional on these models

X – Standard

0 – Add-On Option

# FUNCTIONAL COMPONENTS - LEFT

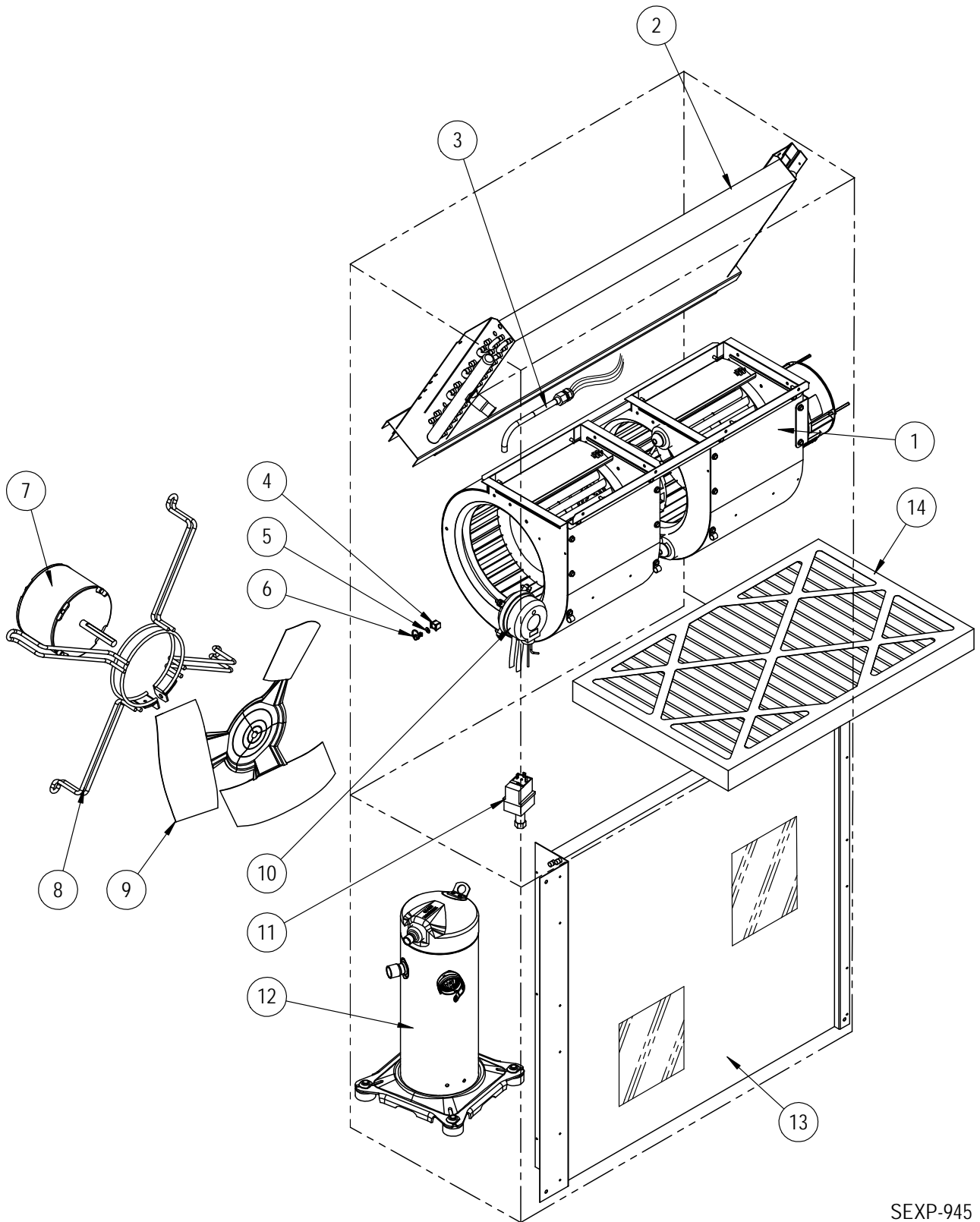

SEXP-945



## FUNCTIONAL COMPONENTS – LEFT

Dwg No.	Part Number	Description	J18LB-A	J24LB-A	J24LB-B
1	S900-363-002	Blower Assembly		X	X
1	S900-363-001	Blower Assembly	X		
2	917-0381BX	Evaporator Coil with Distributor Assembly	X		
2	917-0353BX	Evaporator Coil with Distributor Assembly		X	X
3	800-0458	Distributor Assembly	X		
3	800-0481	Distributor Assembly		X	X
4	1171-023	1/4" Receptacle	X	X	X
5	1171-024	1/4" Turn Retainer	X	X	X
6	1171-022	1/4" Turn Fastener	X	X	X
7	8103-028	Condenser Motor	X	X	X
8	8200-001	Fan Motor Mount	X	X	X
9	5151-033	Fan Blade	X	X	X
10	CMC-31	Dirty Filter Switch Kit	X	X	X
11	CMA-37	Low Ambient Control (Screw On) ①		O	O
12	8000-433	Compressor	X		
12	8000-434	Compressor		X	
12	8000-435	Compressor			X
13	5051-205BX	Condenser Coil	X		
13	5051-204BX	Condenser Coil		X	X
14	7004-025	Air Filter 2" Pleated (16x25x2)	X	X	X
14	7004-011	Air Filter 1" Throw-Away ① (16x25x1)	O	O	O
14	7003-032	Air Filter 1" Washable ① (16x25x1)	O	O	O
14	7004-059	Air Filter 2" Pleated – MERV11 ① (16x25x2)	O	O	O
14	7004-061	Air Filter 2" Pleated – MERV13 ① (16x25x2)	O	O	O
NS	8406-142	High Pressure Switch (Screw On)	X	X	X
NS	8406-140	Low Pressure Switch (Screw On)	X	X	X
NS	5201-021	Filter Drier	X	X	X
NS	5451-024	Tubing Isolation Grommet	X	X	X
NS	6031-009	Coremax Valve Core	X	X	X
NS	1171-028	Filter Door Clip	2	2	2
NS	1171-057	Filter Door Screw	2	2	2
NS	1171-027	Filter Door Screw Retainer	2	2	2

NS – Not Shown  
 ① – Optional on these models

X – Standard  
 O – Add-On Option

# CONTROL PANEL - RIGHT

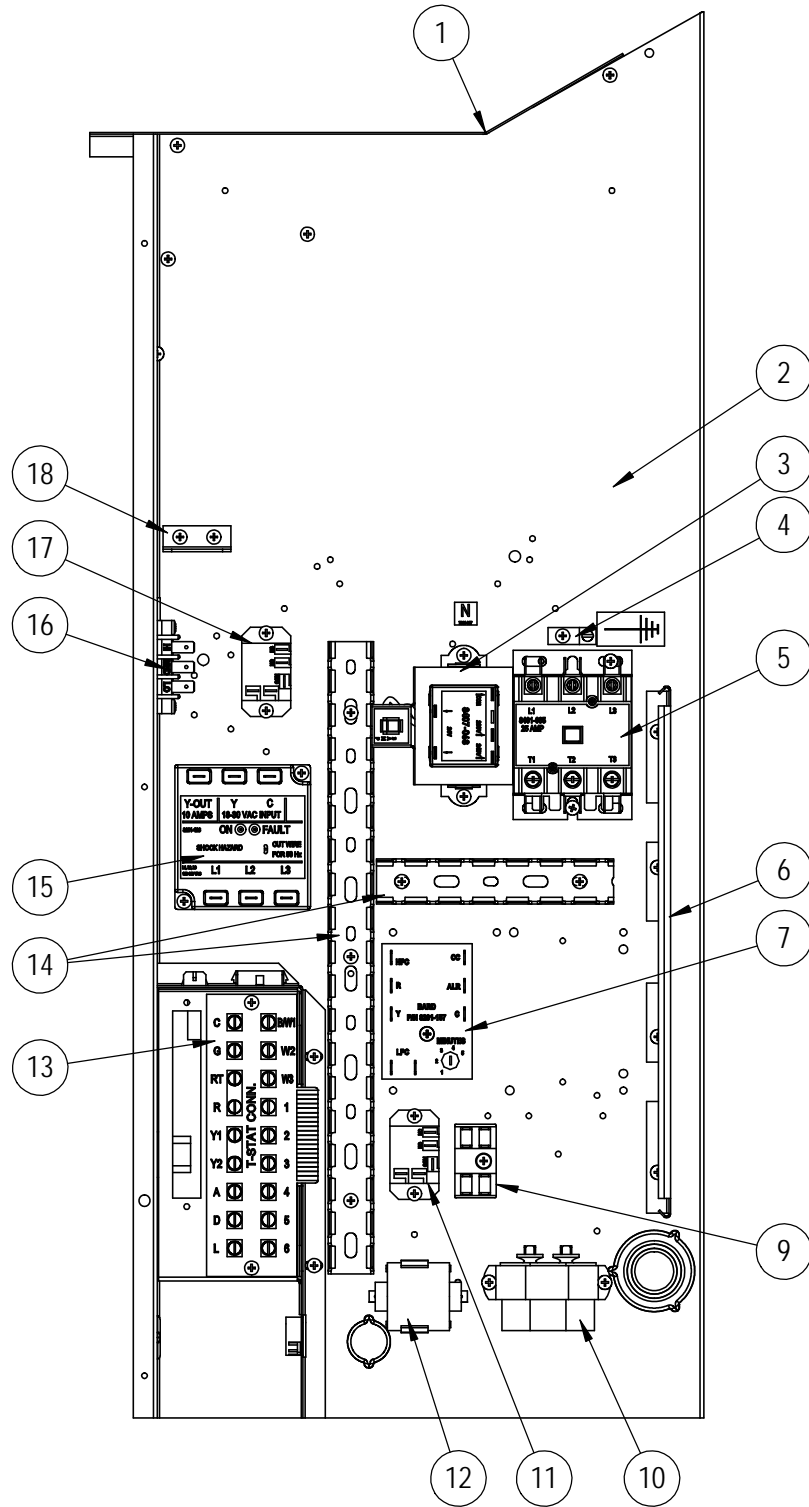

SEXP-908

## CONTROL PANEL – RIGHT

Dwg No.	Part Number	Description	J18AB-A	J24AB-A	J24AB-B	J24AB-C
1	117X137	Control Panel Top	X	X	X	X
2	117X407	Control Panel	X	X	X	X
3	8407-068	Transformer	X	X	X	
3	8407-069	Transformer				X
4	8611-006	Ground Terminal	X	X	X	X
5	8401-033	Compressor Contactor	X	X		
5	8401-035	Compressor Contactor			X	X
6	135-122	Wire Shield	X	X	X	X
7	8201-171BX	Compressor Control Module	X	X	X	X
9	8607-017	Terminal Block (Optional)	X	X	X	X
10	8552-047	Compressor Capacitor	X			
10	8552-050	Compressor Capacitor		X		
10	S8552-002	Outdoor Motor Capacitor			X	X
11	8201-130	Alarm Relay (Optional)	X	X	X	X
12	8551-004	Start Device (PTCR) (Optional)	X	X		
13	8607-063	Low Voltage Terminal Strip	X	X	X	X
14	8611-140-1400	Cable Duct – 14" Piece	X	X	X	X
14	8611-140-0500	Cable Duct – 5" Piece	X	X	X	X
15	8201-174BX	Phase Monitor			X	X
16	8607-042	Blower Speed Terminal	X	X	X	X
17	8201-130	Blower Control Relay	X	X	X	X
18	141-188	Plug Support Bracket	X	X	X	X
NS	3000-1598	Blower Power Plug	X	X	X	X
NS	3000-1607	Blower Speed Plug	X			
NS	3000-1599	Blower Speed Plug		X	X	X
NS	3000-1524	Vent Jumper Plug	X	X	X	X
NS	8615-035	Circuit Breaker 20A 2 Pole (Opt.) ①	X			
NS	8615-036	Circuit Breaker 25A 2 Pole (Opt.) ①		X		
NS	8615-095	Toggle Disconnect (Optional) ①				X
NS	8615-054	Circuit Breaker 20A 3 Pole (Opt.) ①			X	
NS	4095-197	Wiring Diagram	X			
NS	4095-196	Wiring Diagram		X		
NS	4095-296	Wiring Diagram			X	
NS	4095-381	Wiring Diagram				X
NS	3000-1224	Compressor Plug/Harness	X	X		
NS	3000-1231	Compressor Plug/Harness			X	X
NS	3003-047	Control Panel Harness		X		
NS	3003-048	Control Panel Harness			X	X
NS	3003-052	Control Panel Harness	X			
NS	3000-1608	Low Voltage Terminal Block Harness	X	X	X	X
NS	S910-2047	Complete Low Voltage Box Assembly (Sheet Metal, Low Voltage Terminal Strip & Wire Harness)	X	X	X	X

NS = Not Shown

① Circuit breakers listed are for units without electric heat, "OZ" models. See heater replacement parts manual for units with electric heat.

# CONTROL PANEL - LEFT

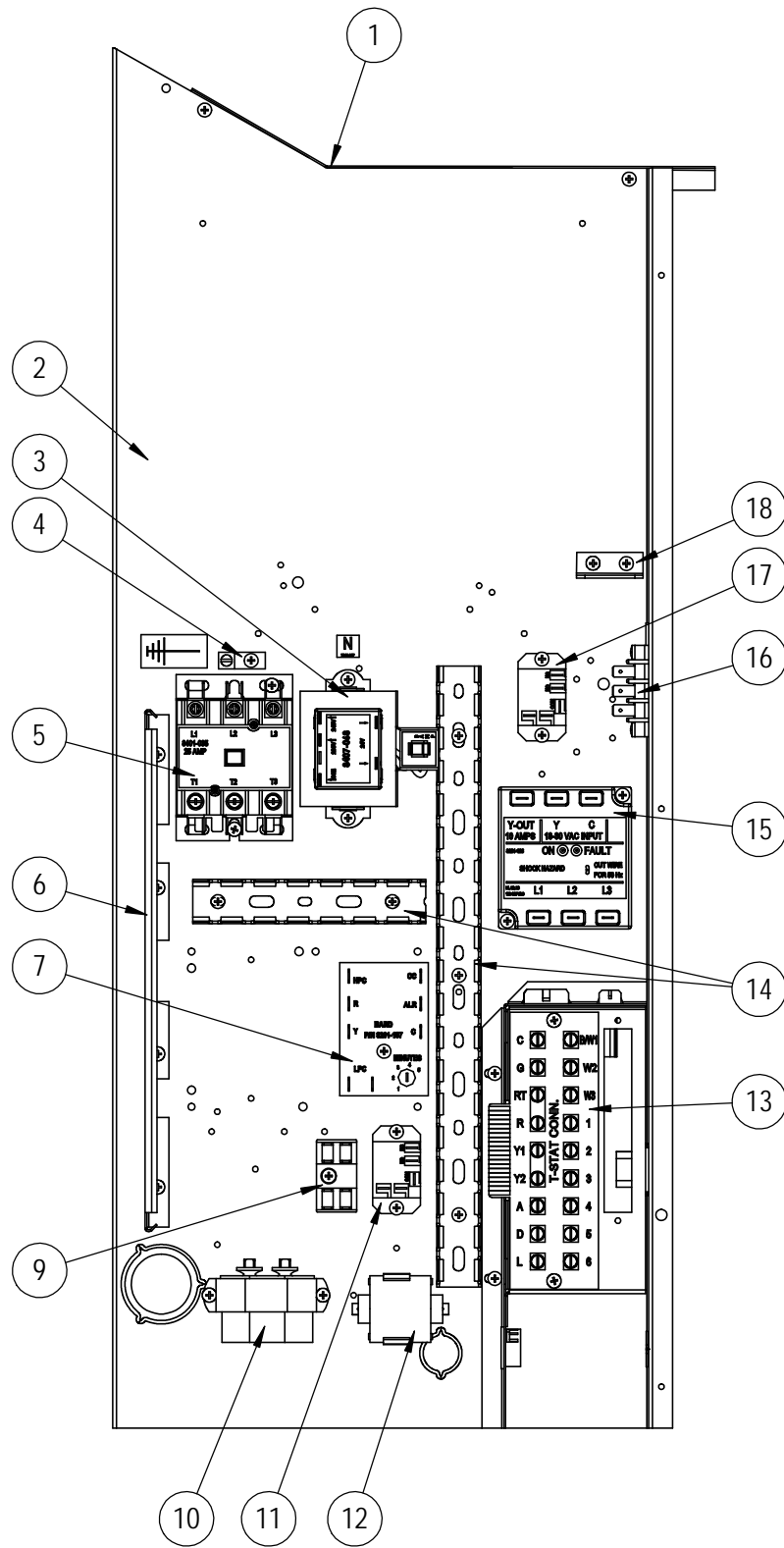

SEXP-947

## CONTROL PANEL – LEFT

Dwg No.	Part Number	Description	J18LB-A	J24LB-A	J24LB-B
1	117Y137	Control Panel Top	X	X	X
2	117Y407	Control Panel	X	X	X
3	8407-068	Transformer	X	X	X
4	8611-006	Ground Terminal	X	X	X
5	8401-033	Compressor Contactor	X	X	
5	8401-035	Compressor Contactor			X
6	135-122	Wire Shield	X	X	X
7	8201-171BX	Compressor Control Module	X	X	X
9	8607-017	Terminal Block (Optional)	X	X	X
10	8552-047	Compressor Capacitor	X		
10	8552-050	Compressor Capacitor		X	
10	S8552-002	Outdoor Motor Capacitor			X
11	8201-130	Alarm Relay (Optional)	X	X	X
12	8551-004	Start Device (PTCR) (Optional)	X	X	X
13	8607-062	Low Voltage Terminal Strip	X	X	X
14	8611-140-1400	Cable Duct – 14" Piece	X	X	X
14	8611-140-0500	Cable Duct – 5" Piece	X	X	X
15	8201-174BX	Phase Monitor			X
16	8607-042	Blower Speed Terminal	X	X	X
17	8201-130	Blower Control Relay	X	X	X
18	141-188	Plug Support Bracket	X	X	X
NS	3000-1598	Bower Power Plug	X	X	X
NS	3000-1607	Blower Speed Plug	X		
NS	3000-1599	Blower Speed Plug		X	X
NS	3000-1524	Vent Jumper Plug	X	X	X
NS	8615-035	Circuit Breaker 20A 2 Pole (Opt.) ①	X		
NS	8615-036	Circuit Breaker 25A 2 Pole (Opt.) ①		X	
NS	8615-054	Circuit Breaker 20A 3 Pole (Opt.) ①			X
NS	4095-197	Wiring Diagram	X		
NS	4095-196	Wiring Diagram		X	
NS	4095-296	Wiring Diagram			X
NS	3000-1224	Compressor Plug/Harness	X	X	
NS	3000-1231	Compressor Plug/Harness			X
NS	3003-047	Control Panel Harness		X	
NS	3003-048	Control Panel Harness			X
NS	3003-052	Control Panel Harness	X		
NS	3000-1608	Low Voltage Terminal Block Harness	X	X	X
NS	S910-2048	Complete Low Voltage Box Assembly (Sheet Metal, Low Voltage Terminal Strip & Wire Harness)	X	X	X

NS = Not Shown

① Circuit breakers listed are for units without electric heat, "OZ" models. See heater replacement parts manual for units with electric heat.

# BLOWER ASSEMBLY - RIGHT

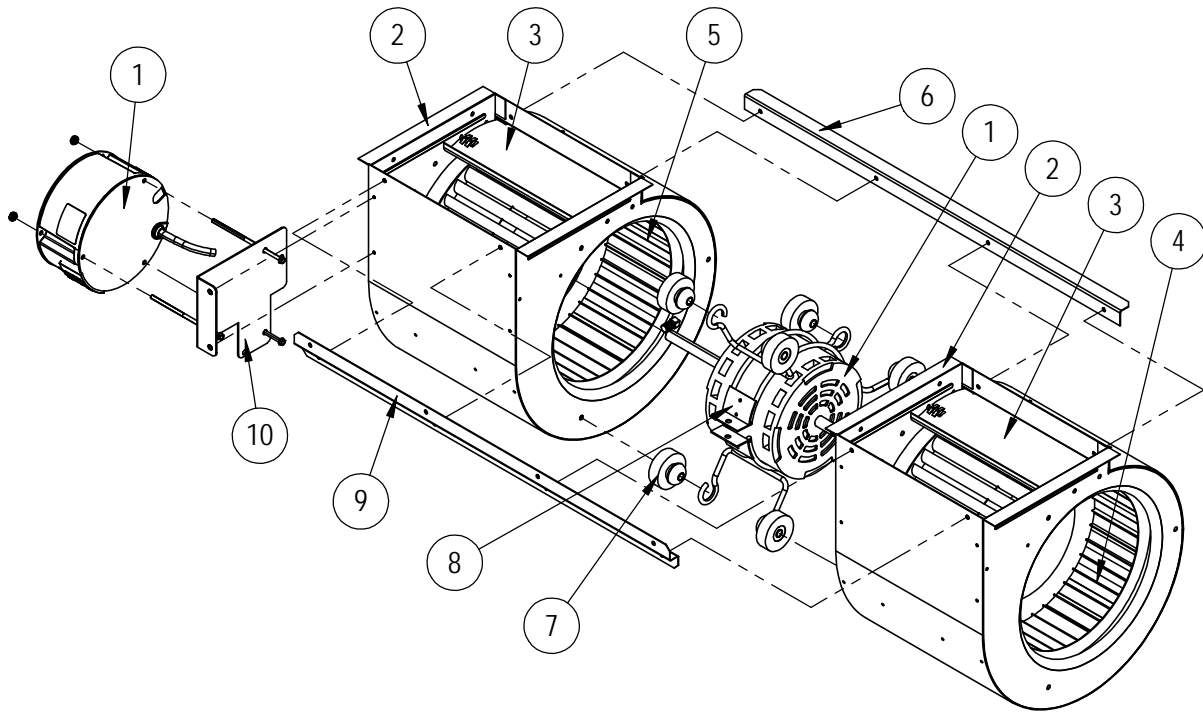

SEXP-909

Dwg No.	Part Number	Description	S900-358-001	S900-358-002	S900-359-001
1	S8105-064-0147	Blower Motor & Control (230/208V)	X		
1	S8105-064-0148	Blower Motor & Control (230/208V)		X	
1	S8105-065-0149	Blower Motor & Control (460V)			X
1	C8105-064-0147	Programmed Control Only (230/208V)	0		
1	C8105-064-0148	Programmed Control Only (230/208V)		0	
1	C8105-065-0149	Programmed Control Only (460V)			0
2	151-115	Housing	2	2	2
3	144-183	Cutoff	X	X	X
4	5152-092	Wheel 9-6 CW	X	X	X
5	5152-093	Wheel 9-6 CCW	X	X	X
6	105-1061	Back Brace	X	X	X
7	5451-011	Grommets	6	6	6
8	8200-031	Motor Mount	X	X	X
9	103-435	Front Brace	X	X	X
10	113-721	Motor Control Bracket	X	X	

# BLOWER ASSEMBLY - LEFT

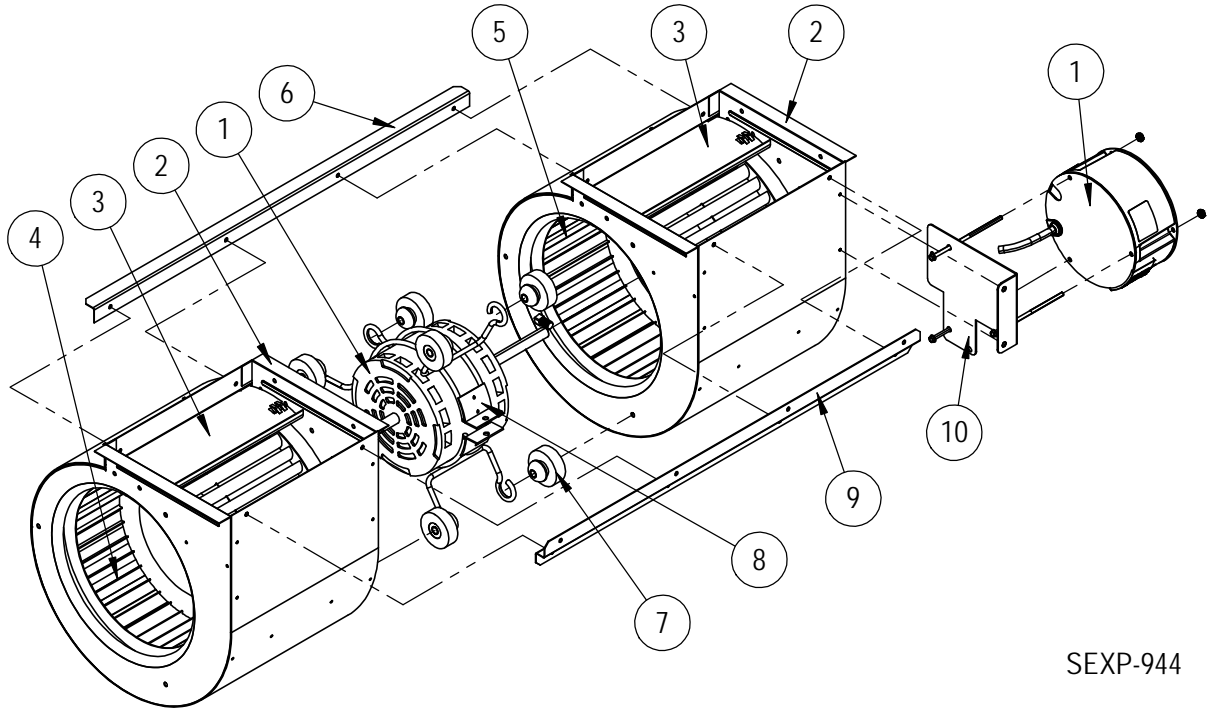

SEXP-944

Dwg No.	Part Number	Description	S900-363-001	S900-363-002
1	S8105-064-0147	Blower Motor & Control (230/208V)	X	
1	S8105-064-0148	Blower Motor & Control (230/208V)		X
1	C8105-064-0147	Programmed Control Only (230/208V)	0	
1	C8105-064-0148	Programmed Control Only (230/208V)		0
2	151-115	Housing	2	2
3	144-183	Cutoff	X	X
4	5152-092	Wheel 9-6 CW	X	X
5	5152-093	Wheel 9-6 CCW	X	X
6	105-1061	Back Brace	X	X
7	5451-011	Grommets	6	6
8	8200-031	Motor Mount	X	X
9	103-435	Front Brace	X	X
10	113-761	Motor Control Bracket	X	X