REPLACEMENT PARTS MANUAL

Wall Mounted Packaged Air Conditioner

Models:

J30AB-A	J30LB-A	J36AB-A	J36LB-A
J30AB-B	J30LB-B	J36AB-B	J36LB-B
J30AB-C	J30LB-C	J36AB-C	J36LB-C

Contents

Description	Page	Description	Page
Cabinet Components – Right Hand Models		Blower Assembly – Right Hand Models	
♦ Exploded View	2	♦ Exploded View	14
♦ Usage List	3	♦ Usage List	14
Cabinet Components – Left Hand Models		Blower Assembly – Left Hand Models	
♦ Exploded View	4	♦ Exploded View	15
♦ Usage List	5	♦ Usage List	15
Functional Components – Right Hand Models		General Notes	
♦ Exploded View	6	➤ Revised and/or additional pages may be issued from time to time.	
♦ Usage List	7	➤ A complete and current manual consists of pages shown in the following contents section.	
Functional Components – Left Hand Models		Important	
♦ Exploded View	8	➤ Contact the installing and/or local Bard distributor for all parts requirements. Make sure to have the complete model and serial number available from the unit rating plates.	
♦ Usage List	9		
Control Panel – Right Hand Models			
♦ Exploded View	10		
♦ Usage List	11		
Control Panel – Left Hand Models			
♦ Exploded View	12		
♦ Usage List	13		



Manual: 2110-1454E
Supersedes: 2110-1454D
Date: 6-28-21

CABINET COMPONENTS - RIGHT

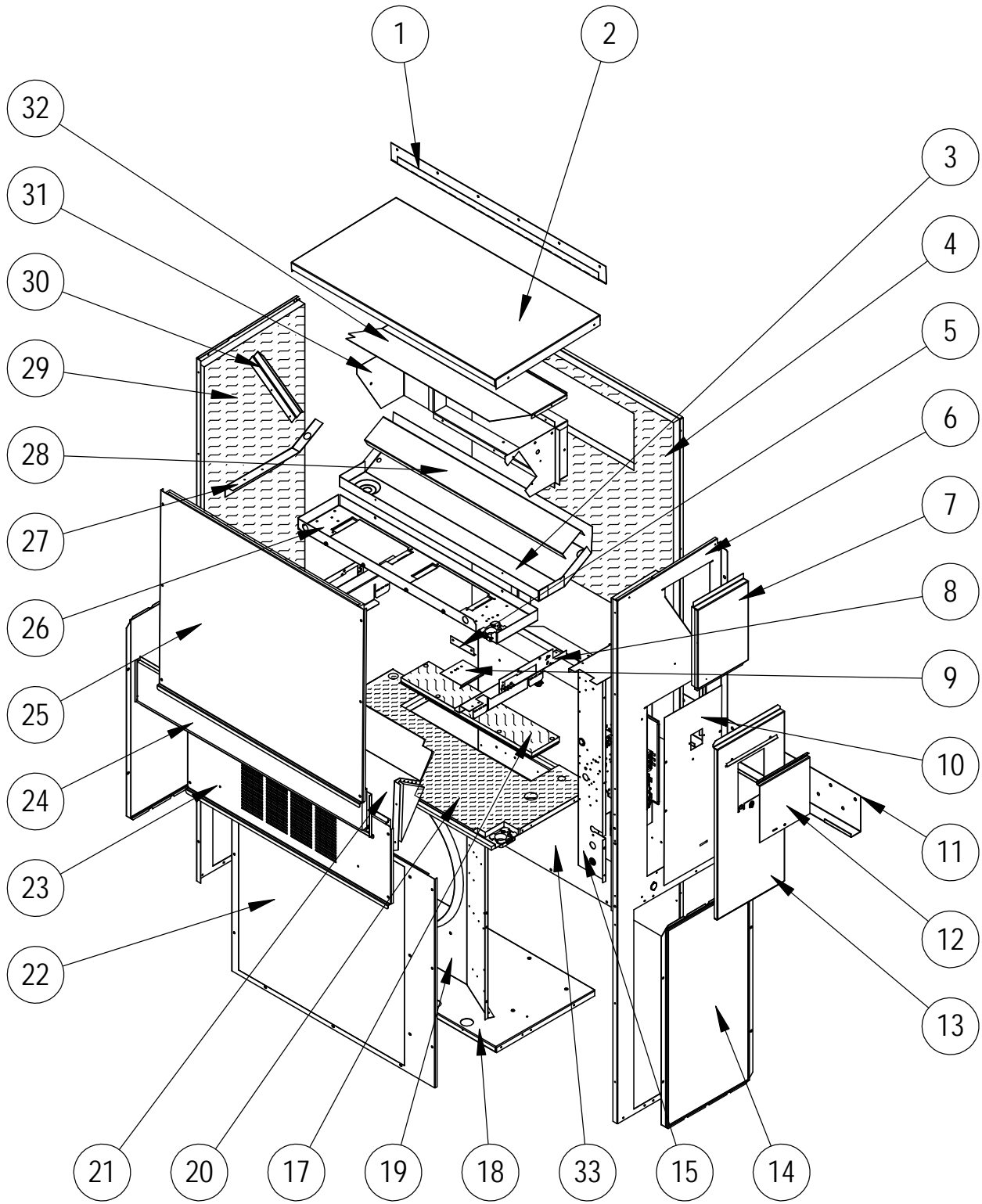

SEXP-907 C

CABINET COMPONENTS – RIGHT

Dwg No.	Part Number	Description	J30AB-A, B	J30AB-C	J36AB-A, B	J36AB-C
1	113-149-X	Top Rain Flashing	X	X	X	X
2	S507-308-X	Top	X	X	X	X
3	S123-127	Drain Pan	X	X	X	X
4	S509-451	Upper Back	X	X	X	X
5	105-1302	Grommet Retainer	X	X	X	X
6	S501-933-X	Right Side	X	X	X	X
7	S543-175-X	Right Side Cover Plate (Outer)	X	X	X	X
8	113X480	Filter Bracket	2	2	2	2
9	137-259	Fill Plate	X	X	X	X
10	S132-104	Control Panel Cover (Inner)	X		X	
10	S132-172	Control Panel Cover (Inner)		X		X
11	113-140	Bottom Mounting Bracket	X	X	X	X
12	S153-218-X	Disconnect Access Door	X	X	X	X
13	S533-228-X	Control Panel Cover (Outer)	X	X	X	X
14	118-105-X	Side Grille	2	2	2	2
15	Control Panel Assembly	See Control Panel Assy. Drawing & Parts List Assy.	X	X	X	X
17	S536-498	Cond. Partition Block Off Plate	X	X	X	X
18	127-471	Lower Base	X	X	X	X
19	125-081	Fan Shroud	X	X	X	X
20	S521X527	Condenser Partition	X	X	X	X
21	FAD-NE3	Fresh Air Damper Assembly	X	X	X	X
22	118-103-X	Condenser Grille	X	X	X	X
23	S553-523-X	Vent Option Door	X	X	X	X
24	S553-524-X	Filter Door	X	X	X	X
25	S514-264-X	Upper Front	X	X	X	X
26	121X467	Blower Partition	X	X	X	X
27	105X850	Side Support	X	X	X	X
28	137-685	Bottom Evaporator Fill	X	X	X	X
29	S501-934-X	Left Side	X	X	X	X
30	147-044	Evaporator Support	X	X	X	X
31	S111X247	Outlet Air Frame Assembly	X	X	X	X
32	135X123	Heat Shield	X	X	X	X
33	109-450	Lower Back	X	X	X	X
NS	135-329	Air Baffle	X	X	X	X

CABINET COMPONENTS - LEFT

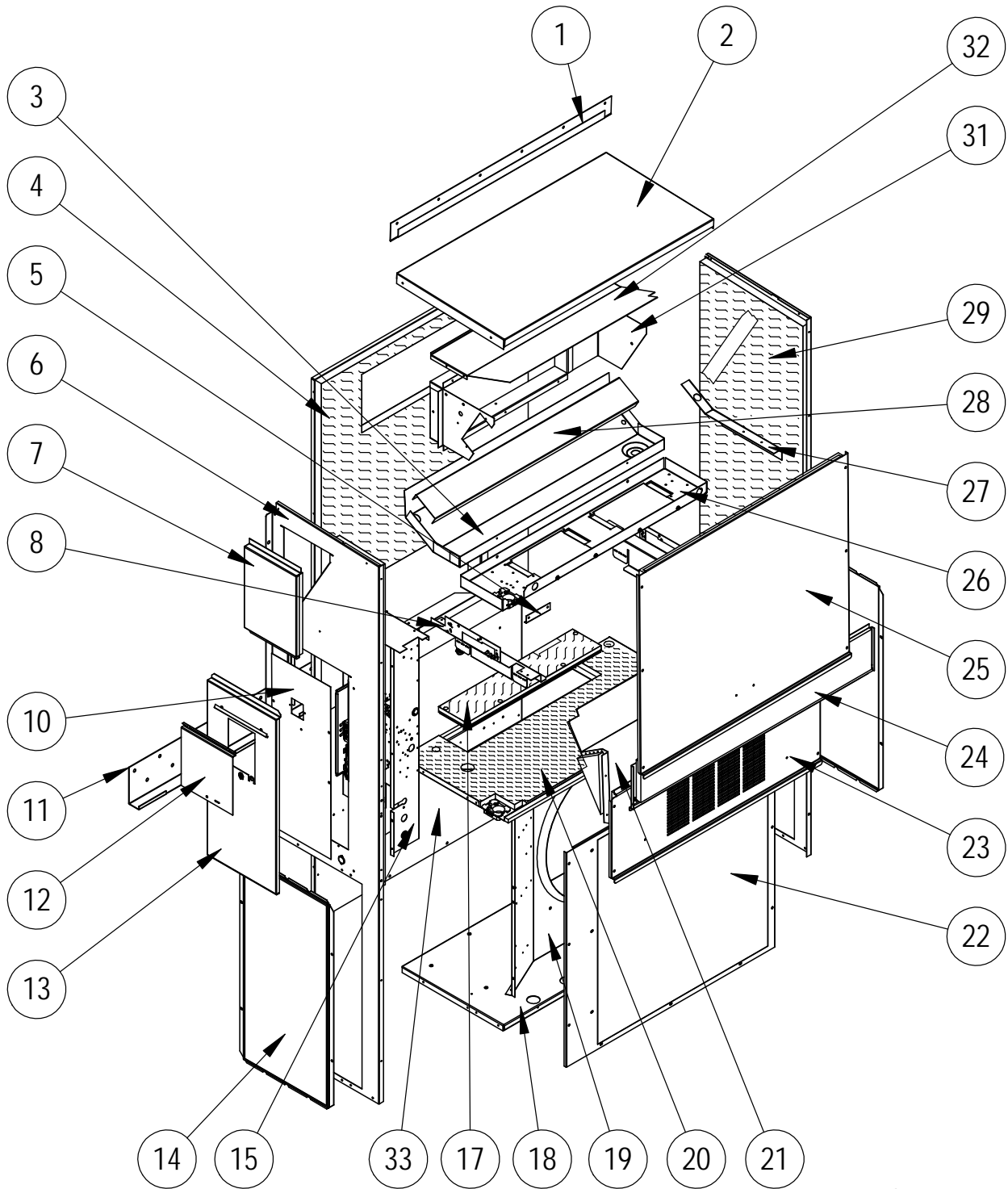

SEXP-946 B

CABINET COMPONENTS – LEFT

Dwg No.	Part Number	Description	J30LB-A, B	J30LB-C	J36LB-A, B	J36LB-C
1	113-149-X	Top Rain Flashing	X	X	X	X
2	S507-308-X	Top	X	X	X	X
3	S123-130	Drain Pan	X	X	X	X
4	S508-343	Back	X	X	X	X
5	105-1302	Grommet Retainer	X	X	X	X
6	S501-935-X	Right Side	X	X	X	X
7	S543-175-X	Right Side Cover Plate (Outer)	X	X	X	X
8	113Y480	Filter Bracket	2	2	2	2
9	137-259	Fill Plate	X	X	X	X
10	S132-104	Control Panel Cover (Inner)	X		X	
10	S132-172	Control Panel Cover (Inner)		X		X
11	113-140	Bottom Mounting Bracket	X	X	X	X
12	S153-218-X	Disconnect Access Door	X	X	X	X
13	S533-228-X	Control Panel Cover (Outer)	X	X	X	X
14	118-105-X	Side Grille	2	2	2	2
15	Control Panel Assembly	See Control Panel Assy. Drawing & Parts List Assy.	X	X	X	X
17	S536-498	Cond. Partition Block Off Plate	2	2	2	2
18	S127-472	Lower Base	X	X	X	X
19	125-081	Fan Shroud	X	X	X	X
20	S521Y527	Condenser Partition	X	X	X	X
21	FAD-NE3	Fresh Air Damper Assembly	X	X	X	X
22	118-104-X	Condenser Grille	X	X	X	X
23	S553-523-X	Vent Option Door	X	X	X	X
24	S553-524-X	Filter Door	X	X	X	X
25	S514-264-X	Upper Front	X	X	X	X
26	121Y467	Blower Partition	X	X	X	X
27	105Y850	Side Support	X	X	X	X
28	137-685	Bottom Evaporator Fill	X	X	X	X
29	S501-936-X	Left Side	X	X	X	X
30	147-044	Evaporator Support	X	X	X	X
31	S111Y030	Outlet Air Frame Assembly	X	X	X	X
32	135Y123	Heat Shield	X	X	X	X
NS	135-329	Air Baffle	X	X	X	X

FUNCTIONAL COMPONENTS - RIGHT

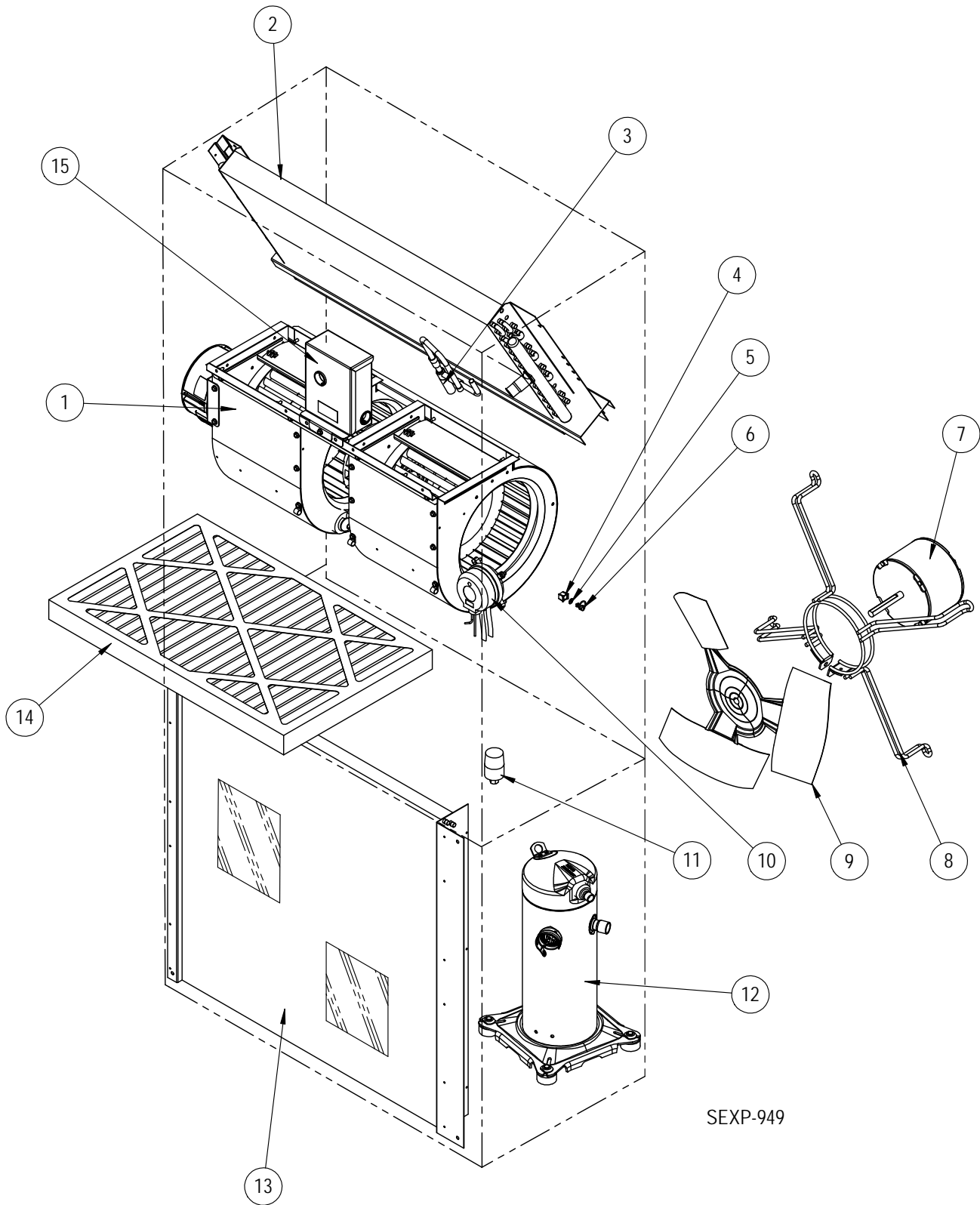

FUNCTIONAL COMPONENTS – RIGHT

Dwg No.	Part Number	Description	J30AB-A	J30AB-B	J30AB-C	J36AB-A	J36AB-B	J36AB-C
1	S900-360-001	Blower Assembly	X	X				
1	S900-361-001	Blower Assembly			X			
1	S900-360-002	Blower Assembly				X	X	
1	S900-361-002	Blower Assembly						X
2	917-0355BX	Evaporator Coil w/Distributor Assy.	X	X	X			
2	917-0357BX	Evaporator Coil w/Distributor Assy.				X	X	X
3	800-0456	Distributor Assembly				X	X	X
3	800-0479	Distributor Assembly	X	X	X			
4	1171-023	1/4" Receptacle	X	X	X	X	X	X
5	1171-024	1/4" Turn Retainer	X	X	X	X	X	X
6	1171-022	1/4" Turn Fastener	X	X	X	X	X	X
7	8103-029	Condenser Motor	X	X		X	X	
7	8103-030	Condenser Motor			X			X
8	8200-001	Fan Motor Mount	X	X	X	X	X	X
9	S5151-045	Fan Blade	X	X	X	X	X	X
10	CMC-31	Dirty Filter Switch Kit	X	X	X	X	X	X
11	CMA-39	Low Ambient Control (Screw On) ①	O	O	O	O	O	O
12	8000-277	Compressor	X					
12	8000-365	Compressor		X				
12	8000-366	Compressor			X			
12	8000-438	Compressor				X		
12	8000-278	Compressor					X	
12	8000-283	Compressor						X
12	8000-342	Compressor						X
13	5051-203BX	Condenser Coil	X	X	X			
13	5051-202BX	Condenser Coil				X	X	X
14	7004-026	Air Filter 2" Pleated (16x30x2)	X	X	X	X	X	X
14	7004-019	Air Filter 1" Throw-Away ① (16x30x1)	O	O	O	O	O	O
14	7003-031	Air Filter 1" Washable ① (16x30x1)	O	O	O	O	O	O
14	7004-048	Air Filter 2" Pleated MERV 11 ① (16x30x2)	O	O	O	O	O	O
14	7004-062	Air Filter 2" Pleated MERV 13 ① (16x30x2)	O	O	O	O	O	O
NS	8406-142	High Pressure Switch (Screw On)	X	X	X	X	X	X
NS	8406-140	Low Pressure Switch (Screw On)	X	X	X	X	X	X
NS	5201-021	Filter Drier	X	X	X	X	X	X
NS	5451-024	Tubing Isolation Grommet	2	2	2	2	2	2
NS	6031-009	Coremax Valve Core	2	2	2	2	2	2
NS	1171-028	Filter Door Clip	2	2	2	2	2	2
NS	1171-057	Filter Door Screw	2	2	2	2	2	2
NS	1171-027	Filter Door Screw Retainer	2	2	2	2	2	2

NS – Not Shown

① – Optional on these models

X – Standard

O – Add-On Option

FUNCTIONAL COMPONENTS - LEFT

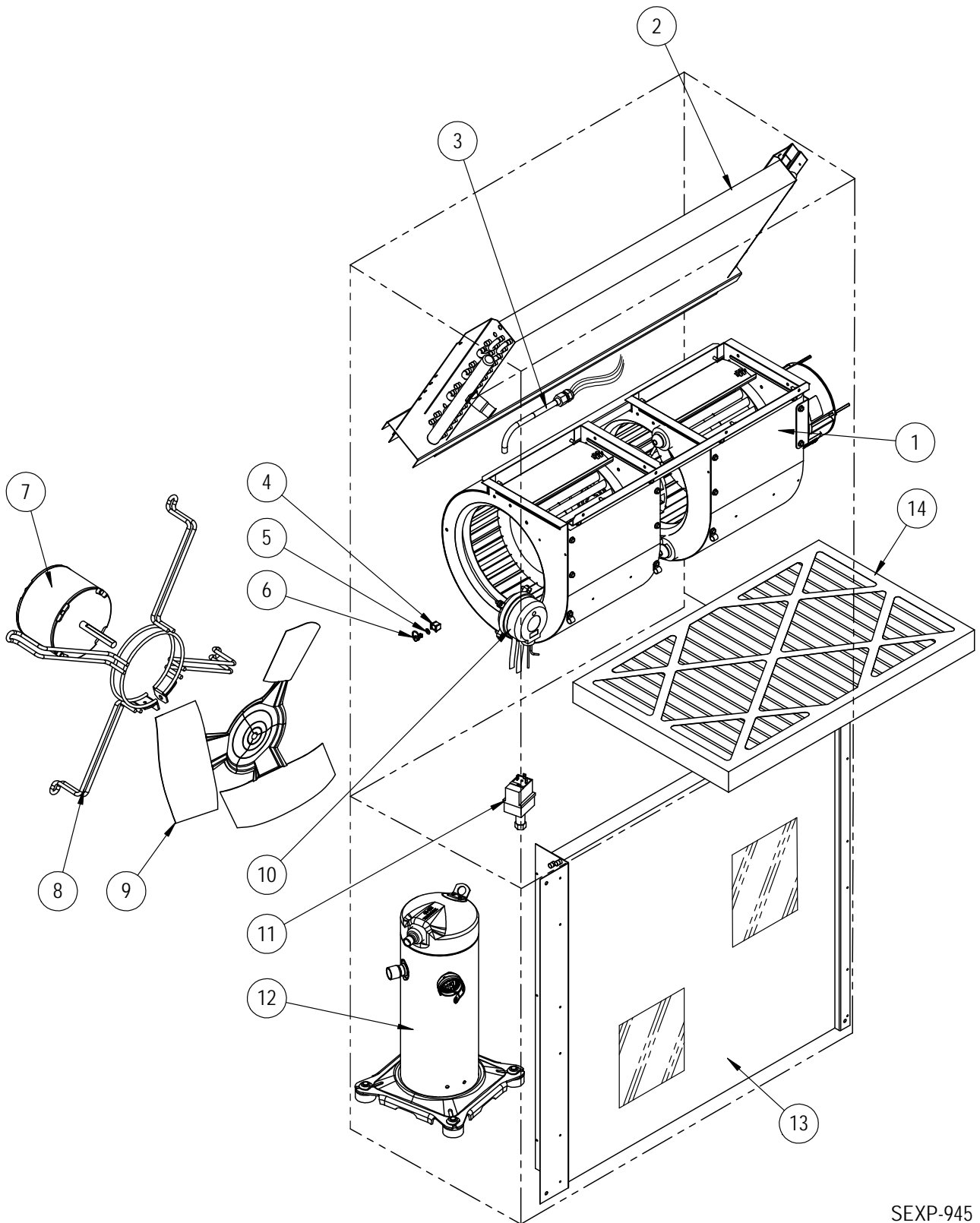

SEXP-945

FUNCTIONAL COMPONENTS – LEFT

Dwg No.	Part Number	Description	J30LB-A	J30LB-B	J30LB-C	J36LB-A	J36LB-B	J36LB-C
1	S900-364-001	Blower Assembly	X	X				
1	S900-365-001	Blower Assembly			X			
1	S900-364-002	Blower Assembly				X	X	
1	S900-365-002	Blower Assembly						X
2	917-0355	Evaporator Coil w/Distributor Assy.	X	X	X			
2	917-0357	Evaporator Coil w/Distributor Assy.				X	X	X
3	800-0456	Distributor Assembly				X	X	X
3	800-0479	Distributor Assembly	X	X	X			
4	1171-023	1/4" Receptacle	X	X	X	X	X	X
5	1171-024	1/4" Turn Retainer	X	X	X	X	X	X
6	1171-022	1/4" Turn Fastener	X	X	X	X	X	X
7	8103-029	Condenser Motor	X	X		X	X	
7	8103-030	Condenser Motor			X			X
8	8200-001	Fan Motor Mount	X	X	X	X	X	X
9	S5151-045	Fan Blade	X	X	X	X	X	X
10	CMA-31	Dirty Filter Switch Kit	X	X	X	X	X	X
11	CMA-39	Low Ambient Control (Screw On) ①	O	O	O	O	O	O
12	8000-277	Compressor	X					
12	8000-365	Compressor		X				
12	8000-366	Compressor			X			
12	8000-278	Compressor				X		
12	8000-283	Compressor					X	
12	8000-342	Compressor						X
13	5051-203BX	Condenser Coil	X	X	X			
13	5051-202BX	Condenser Coil				X	X	X
14	7004-026	Air Filter 2" Pleated (16x30x2)	X	X	X	X	X	X
14	7004-019	Air Filter 1" Throw-Away ① (16x30x1)	O	O	O	O	O	O
14	7003-031	Air Filter 1" Washable ① (16x30x1)	O	O	O	O	O	O
14	7004-048	Air Filter 2" Pleated – MERV 11 ① (16x30x2)	O	O	O	O	O	O
14	7004-062	Air Filter 2" Pleated – MERV 13 ① (16x30x2)	O	O	O	O	O	O
NS	8406-142	High Pressure Switch (Screw On)	X	X	X	X	X	X
NS	8406-140	Low Pressure Switch (Screw On)	X	X	X	X	X	X
NS	5201-021	Filter Drier	X	X	X	X	X	X
NS	5451-024	Tubing Isolation Grommet	X	X	X	X	X	X
NS	6031-009	Coremax Valve Core	X	X	X	X	X	X
NS	1171-028	Filter Door Clip	X	X	X	X	X	X
NS	1171-057	Filter Door Screw	X	X	X	X	X	X
NS	1171-027	Filter Door Screw Retainer	X	X	X	X	X	X

NS – Not Shown

① – Optional on these models

X – Standard

O – Add-On Option

CONTROL PANEL – RIGHT

Dwg No.	Part Number	Description	J30AB-A	J30AB-B	J30AB-C	J36AB-A	J36AB-B	J36AB-C
1	117X137	Control Panel Top	X	X	X	X	X	X
2	117X407	Control Panel	X	X	X	X	X	X
3	8407-068	Transformer	X	X		X	X	
3	8407-069	Transformer			X			X
4	8611-006	Ground Terminal	X	X	X	X	X	X
5	8401-033	Compressor Contactor	X			X		
5	8401-035	Compressor Contactor		X	X		X	X
6	135-122	Wire Shield	X	X	X	X	X	X
7	S8201-164	Compressor Control Module	X	X	X	X	X	X
9	8607-017	Terminal Block (Optional)	X	X	X	X	X	X
10	8552-052	Compressor Capacitor	X			X		
10	S8552-002	Outdoor Motor Capacitor		X	X		X	X
11	8201-130	Alarm Relay (Optional)	X	X	X	X	X	X
12	8551-004	Start Device (PTCR) (Optional)	X			X		
13	8607-063	Low Voltage Terminal Strip	X	X	X	X	X	X
14	8611-140-1400	Cable Duct – 14" Piece	X	X	X	X	X	X
14	8611-140-0500	Cable Duct – 5" Piece	X	X	X	X	X	X
15	8201-126	Phase Monitor		X	X		X	X
16	8607-042	Blower Speed Terminal	X	X	X	X	X	X
17	8201-130	Blower Control Relay	X	X	X	X	X	X
18	141-188	Plug Support Bracket	X	X	X	X	X	X
NS	8615-038	Circuit Breaker 35A 2 Pole (Opt.) ①	X			X		
NS	8615-054	Circuit Breaker 20A 3 Pole (Opt.) ①		X				
NS	8615-051	Circuit Breaker 25A 3 Pole (Opt.) ①					X	
NS	8615-095	Toggle Disconnect (Optional) ①			X			X
NS	4095-196	Wiring Diagram	X			X		
NS	4095-296	Wiring Diagram		X			X	
NS	4095-378	Wiring Diagram			X			X
NS	3000-1598	Blower Power Plug	X	X	X	X	X	X
NS	3000-1599	Blower Speed Plug	X	X	X	X	X	X
NS	3000-1524	Vent Jumper Plug	X	X	X	X	X	X
NS	3000-1224	Compressor Plug/Harness	X			X		
NS	3000-1231	Compressor Plug/Harness		X	X		X	X
NS	3003-047	Control Panel Harness	X			X		
NS	3003-048	Control Panel Harness		X	X		X	X
NS	3000-1608	Low Voltage Terminal Block Harness	X	X	X	X	X	X
NS	S910-2047	Complete Low Voltage Box Assembly (Sheet Metal, Low Voltage Terminal Strip & Wire Harness)	X	X	X	X	X	X

NS = Not Shown

① Circuit breakers listed are for units without electric heat, "OZ" models. See heater replacement parts manual for units with electric heat.

CONTROL PANEL - LEFT

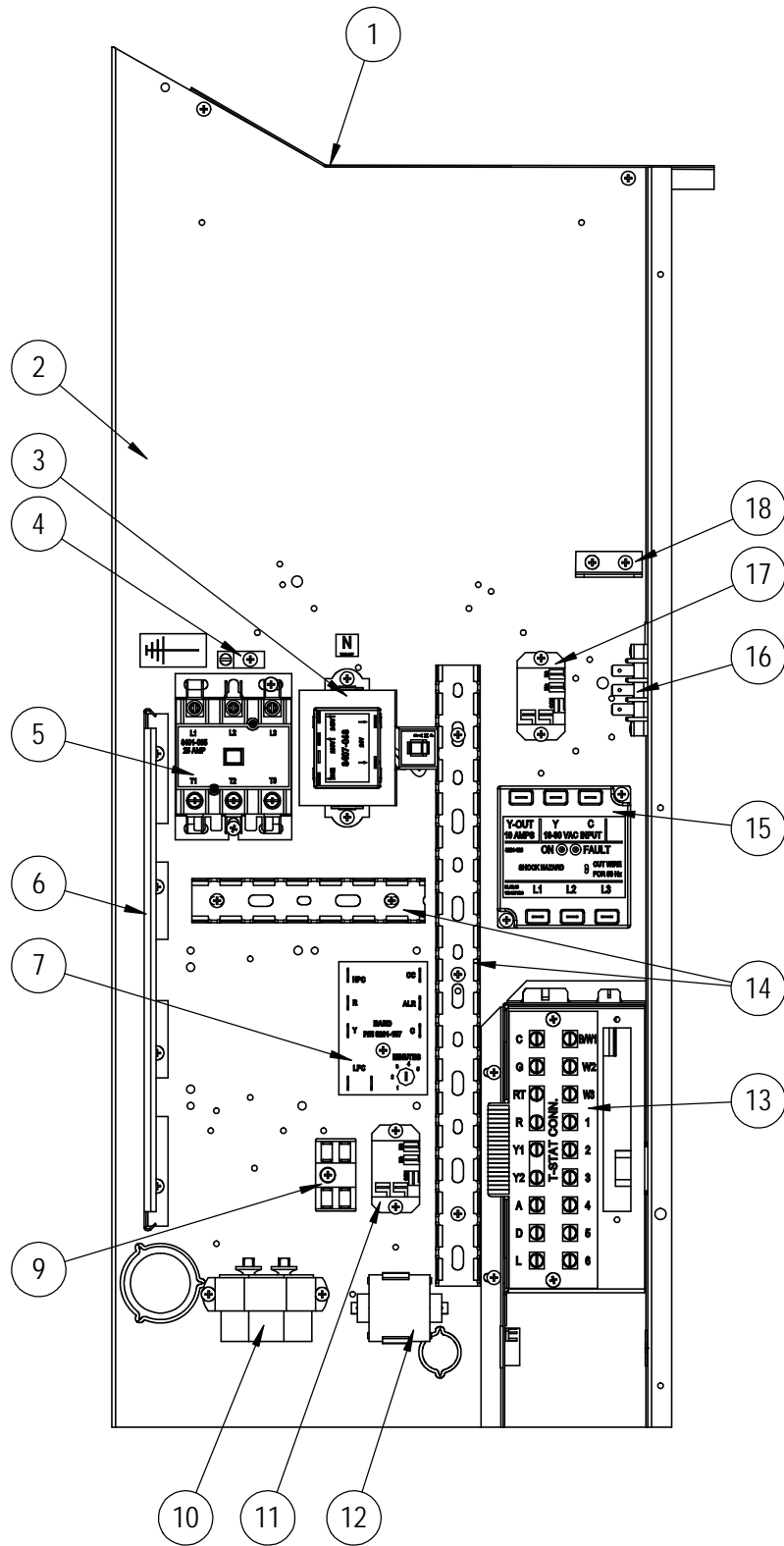

SEXP-947

CONTROL PANEL – LEFT

Dwg No.	Part Number	Description	J30LB-A	J30LB-B	J30LB-C	J36LB-A	J36LB-B	J36LB-C
1	117Y137	Control Panel Top	X	X	X	X	X	X
2	117Y407	Control Panel	X	X	X	X	X	X
3	8407-068	Transformer	X	X		X	X	
3	8407-069	Transformer			X			X
4	8611-006	Ground Terminal	X	X	X	X	X	X
5	8401-033	Compressor Contactor	X			X		
5	8401-035	Compressor Contactor		X	X		X	X
6	135-122	Wire Shield	X	X	X	X	X	X
7	S8201-164	Compressor Control Module	X	X	X	X	X	X
9	8607-017	Terminal Block (Optional)	X	X	X	X	X	X
10	8552-052	Compressor Capacitor	X			X		
10	S8552-002	Outdoor Motor Capacitor		X	X		X	X
11	8201-062	Alarm Relay (Optional)	X	X	X	X	X	X
12	8551-004	Start Device (PTCR) (Optional)	X	X	X	X	X	X
13	8607-062	Low Voltage Terminal Strip	X	X	X	X	X	X
14	8611-140-1400	Cable Duct – 14" Piece	X	X	X	X	X	X
14	8611-140-0500	Cable Duct – 5" Piece	X	X	X	X	X	X
15	8201-126	Phase Monitor		X	X		X	X
16	8607-042	Blower Speed Terminal	X	X	X	X	X	X
17	8201-130	Blower Control Relay	X	X	X	X	X	X
18	141-188	Plug Support Bracket	X	X	X	X	X	X
NS	8615-038	Circuit Breaker 35A 2 Pole (Opt.) ①	X			X		
NS	8615-054	Circuit Breaker 20A 3 Pole (Opt.) ①		X				
NS	8615-051	Circuit Breaker 25A 3 Pole (Opt.) ①					X	
NS	8615-095	Toggle Disconnect (Optional) ①			X			X
NS	4095-196	Wiring Diagram	X			X		
NS	4095-296	Wiring Diagram		X			X	
NS	4095-378	Wiring Diagram			X			X
NS	3000-1598	Blower Power Plug	X	X	X	X	X	X
NS	3000-1599	Blower Speed Plug	X	X	X	X	X	X
NS	3000-1524	Vent Jumper Plug	X	X	X	X	X	X
NS	3000-1224	Compressor Plug/Harness	X			X		
NS	3000-1231	Compressor Plug/Harness		X	X		X	X
NS	3003-047	Control Panel Harness	X			X		
NS	3003-048	Control Panel Harness		X	X		X	X
NS	3000-1608	Low Voltage Terminal Block Harness	X	X	X	X	X	X
NS	S910-2048	Complete Low Voltage Box Assembly (Sheet Metal, Low Voltage Terminal Strip & Wire Harness)	X	X	X	X	X	X

NS = Not Shown

① Circuit breakers listed are for units without electric heat, "OZ" models. See heater replacement parts manual for units with electric heat.

BLOWER ASSEMBLY - RIGHT

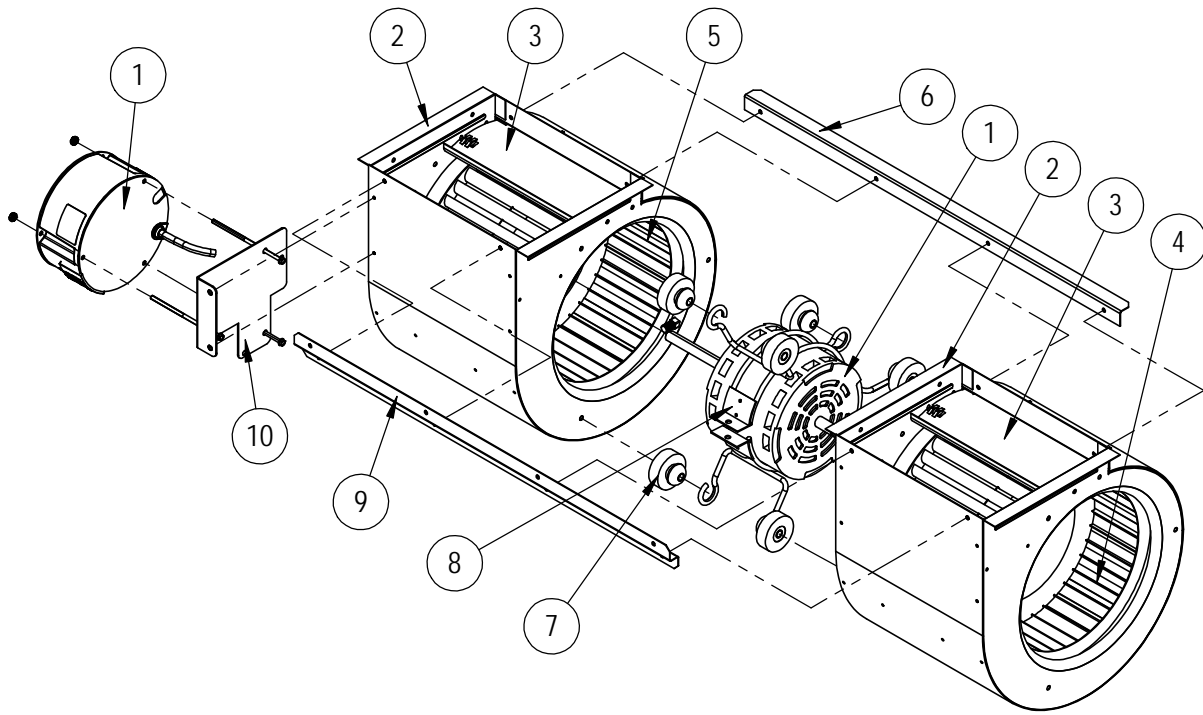

SEXP-909

Dwg No.	Part Number	Description	S900-360-001	S900-360-002	S900-361-001	S900-361-002
1	S8106-068-0150	Blower Motor & Control (230/208V)	X			
1	S8106-068-0152	Blower Motor & Control (230/208V)		X		
1	S8106-069-0151	Blower Motor & Control (460V)			X	
1	S8106-069-0153	Blower Motor & Control (460V)				X
1	C8106-068-0150	Programmed Control Only (230/208V)	0			
1	C8106-068-0152	Programmed Control Only (230/208V)		0		
1	C8106-069-0151	Programmed Control Only (460V)			0	
1	C8106-069-0153	Programmed Control Only (460V)				0
2	151-111	Housing	2	2	2	2
3	144-174	Diffuser	2	2	2	2
4	5152-090	Wheel CW	X	X	X	X
5	5152-091	Wheel CCW	X	X	X	X
6	105-870	Back Brace	X	X	X	X
7	5451-011	Grommets	6	6	6	6
8	8200-031	Motor Mount	X	X	X	X
9	103-401	Front Brace	X	X	X	X
10	113-721	Motor Control Bracket	X	X	X	X

BLOWER ASSEMBLY - LEFT

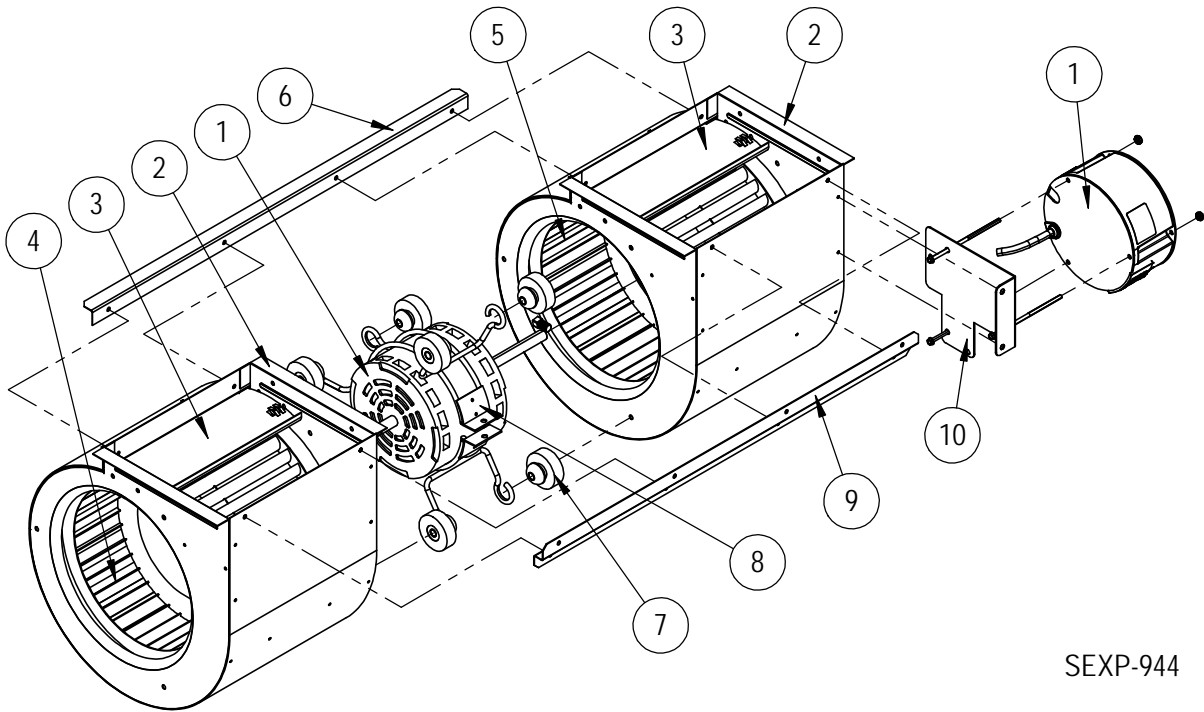

Dwg No.	Part Number	Description	S900-364-001	S900-364-002	S900-365-001	S900-365-002
1	S8106-068-0150	Blower Motor & Control (230/208V)	X			
1	S8106-068-0152	Blower Motor & Control (230/208V)		X		
1	S8106-069-0151	Blower Motor & Control (460V)			X	
1	S8106-069-0153	Blower Motor & Control (460V)				X
1	C8106-068-0150	Programmed Control Only (230/208V)	0			
1	C8106-068-0152	Programmed Control Only (230/208V)		0		
1	C8106-069-0151	Programmed Control Only (460V)			0	
1	C8106-069-0153	Programmed Control Only (460V)				0
2	151-111	Housing	2	2	2	2
3	144-174	Diffuser	2	2	2	2
4	5152-090	Wheel CW	X	X	X	X
5	5152-091	Wheel CCW	X	X	X	X
6	105-870	Back Brace	X	X	X	X
7	5451-011	Grommets	6	6	6	6
8	8200-031	Motor Mount	X	X	X	X
9	103-401	Front Brace	X	X	X	X
10	113-761	Motor Control Bracket	X	X	X	X