

---

# REPLACEMENT PARTS MANUAL

---

## MULTI-TEC® Wall-Mount Air Conditioner

Models:

W18ABPA W24ABPA W24ABPD  
W24ABPB W24ABPF  
W24ABPC

---

### Contents

Description	Page	Description	Page
Cabinet Components		Freecooling Air Hood	
♦ Exploded View .....	2	♦ Exploded View .....	10
♦ Usage List .....	3	♦ Usage List .....	10
Functional Components		Freecooling Damper Motor	
♦ Exploded View .....	4	♦ Exploded View .....	11
♦ Usage List .....	5	♦ Usage List .....	11
Control Panel			
♦ Layout View .....	6		
♦ Usage List .....	7		
Blower Assembly			
♦ Exploded View .....	8		
♦ Usage List .....	8		
Freecooling Components			
♦ Exploded View .....	9		
♦ Usage List .....	9		

### General Notes

- Revised and/or additional pages may be issued from time to time.
- A complete and current manual consists of pages shown in the contents section.

### Important

- Contact the installing and/or local Bard distributor for all parts requirements. Make sure to have the complete model and serial number available from the unit rating plates.



Bard Manufacturing Company, Inc.  
Bryan, Ohio 43506  
www.bardhvac.com

Manual: 2110-1456F  
Supersedes: 2110-1456E  
Date: 7-20-22

# CABINET COMPONENTS

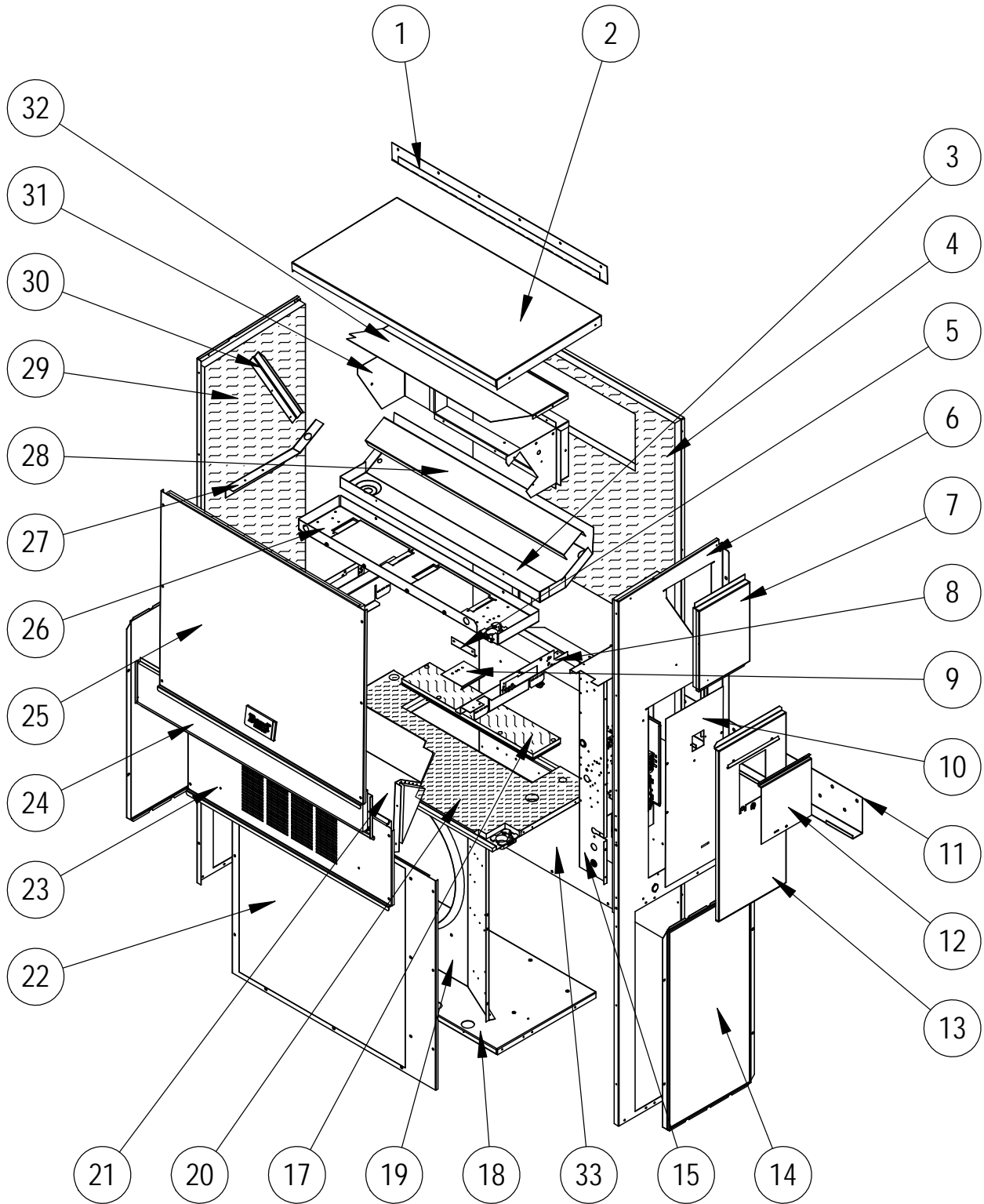

SEXP-907 C

# CABINET COMPONENTS

Dwg No.	Part Number	Description	W18ABPA	W24ABPA, B, D	W24ABPF, C
1	113-141-* ①	Top Rain Flashing	X	X	X
1	113-361 ②	Top Rain Flashing	X	X	X
1	113-141-4 ③	Top Rain Flashing	X	X	X
2	S507-311-* ①	Top	X	X	X
2	S507-318-* ③	Top	X	X	X
2	S507-317 ②	Top	X	X	X
3	S123-126	Drain Pan	X	X	X
3	S123-140 ②③	Drain Pan	X	X	X
4	S509-445	Upper Back	X	X	X
4	S509-447 ③	Upper Back	X	X	X
4	S509-449 ②	Upper Back	X	X	X
5	105-1302	Grommet Retainer	X	X	X
6	S501-933-* ①	Right Side	X	X	X
6	S501-994 ②	Right Side	X	X	X
6	S501-937 ③	Right Side	X	X	X
7	S543-175-* ①	Right Side Cover Plate (Outer)	X	X	X
7	S543-185 ②	Right Side Cover Plate (Outer)	X	X	X
7	S543-184 ③	Right Side Cover Plate (Outer)	X	X	X
8	113X480	Filter Bracket	2	2	2
9	137-259	Fill Plate	X	X	X
10	S132-104	Control Panel Cover (Inner)	X	X	
10	S132-172	Control Panel Cover (Inner)			X
11	113-140	Bottom Mounting Bracket	X	X	X
12	S153-218 ①	Disconnect Access Door	X	X	X
12	S153-405 ②	Disconnect Access Door	X	X	X
12	S153-387 ③	Disconnect Access Door	X	X	X
13	S533-228-* ①	Control Panel Cover (Outer)	X	X	X
13	S533-235 ②	Control Panel Cover (Outer)	X	X	X
13	S533-236 ③	Control Panel Cover (Outer)	X	X	X
14	118-124-* ①	Side Grille	2	2	2
14	118-140 ②	Side Grille	2	2	2
14	118-139 ③	Side Grille	2	2	2
15	Control Panel Assembly	See Control Panel Assy. Drawing & Parts List Assy.	X	X	X
17	S536-176	Cond. Partition Block Off Plate	X	X	X
17	S536-878 ②	Cond. Partition Block Off Plate	X	X	X
18	S127-467	Lower Base	X	X	X
18	S127-534 ②	Lower Base	X	X	X
19	125-080	Fan Shroud	X	X	X
19	125-082 ②	Fan Shroud	X	X	X
20	S521X528	Condenser Partition	X	X	X
20	S521-553 ②	Condenser Partition	X	X	X
22	118-101-* ①	Condenser Grille	X	X	X
22	118-106 ②	Condenser Grille	X	X	X
22	118-111 ③	Condenser Grille	X	X	X
23	S553-537-* ①	Vent Option Door	X	X	X
23	S553-548 ③	Vent Option Door	X	X	X
23	S553-547 ②	Vent Option Door	X	X	X
24	S553-538-* ①	Filter Door	X	X	X
24	S553-552-* ③	Filter Door	X	X	X
24	S553-551 ②	Filter Door	X	X	X
25	S514-240-* ①	Upper Front	X	X	X
25	S514-237-* ③	Upper Front	X	X	X
25	S514-236 ②	Upper Front	X	X	X
26	121X480	Blower Partition	X	X	X
27	105X850	Side Support	X	X	X
28	137-694	Bottom Evaporator Fill	X	X	X
29	S501-934-* ①	Left Side	X	X	X
29	S501-995 ②	Left Side	X	X	X
29	S501-940 ③	Left Side	X	X	X
30	147-044	Evaporator Support	X	X	X
31	S111X032	Outlet Air Frame Assembly	X	X	X
32	135X127	Heat Shield	X	X	X
33	109-444	Lower Back	X	X	X
33	109-446 ③	Lower Back	X	X	X
33	109-448 ②	Lower Back	X	X	X
NS	BOP-2	Blank Off Plate	X	X	X
NS	5252-033	Bard Nameplate	X	X	X

① Exterior cabinet parts are manufactured with various paint color options. To ensure the proper paint color is received, include the complete model and serial number of the unit for which cabinet parts are being ordered.

② Exterior cabinet parts are manufactured from stainless steel Code "S"

③ Exterior cabinet parts are manufactured from aluminum Code "A"

# FUNCTIONAL COMPONENTS

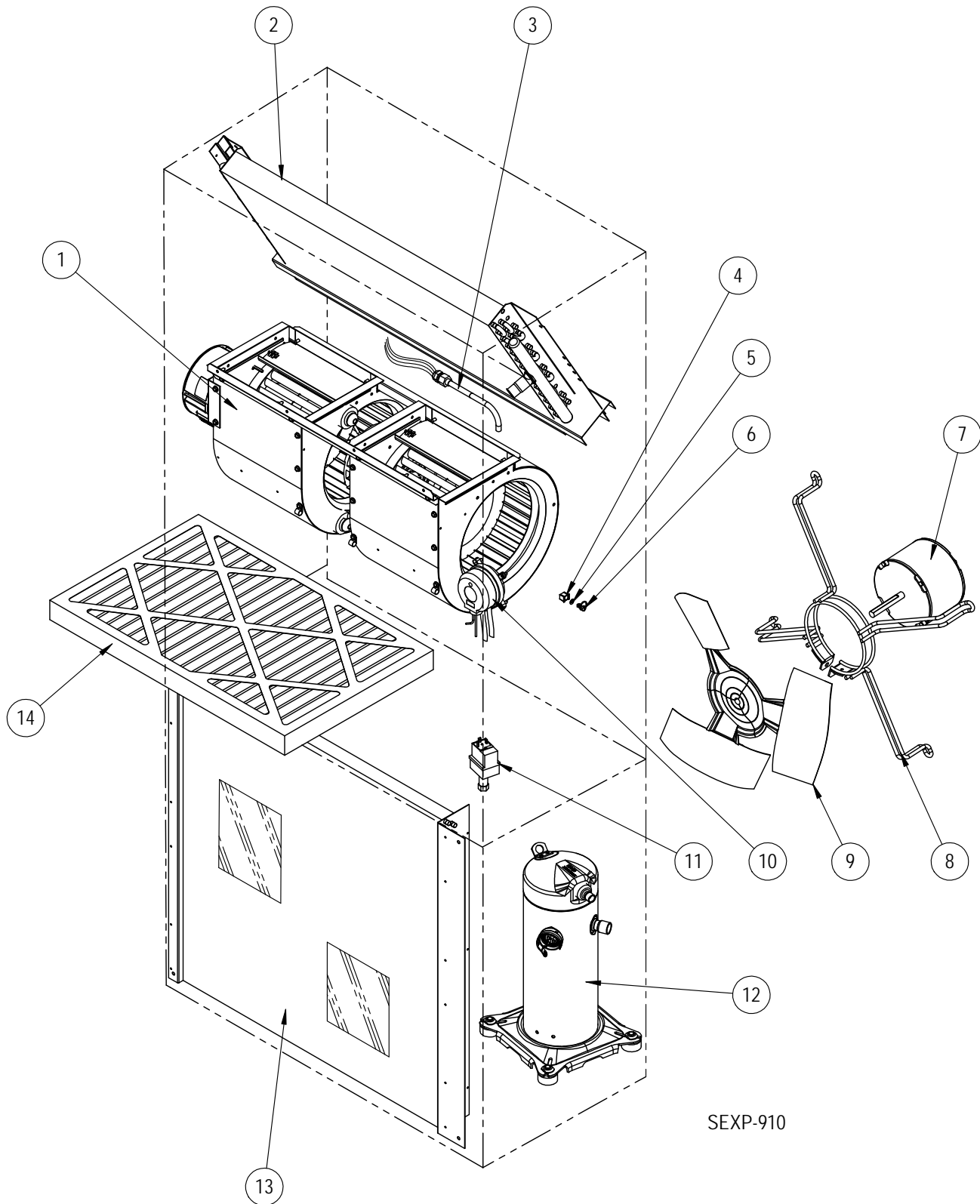

# FUNCTIONAL COMPONENTS

Dwg No.	Part Number	Description	W18ABPA	W24ABPA	W24ABPB	W24ABPC	W24ABPD	W24ABPF
1	S900-358-002	Blower Assembly		X	X		X	X
1	S900-359-001	Blower Assembly				X		
1	S900-358-001	Blower Assembly	X					
2	917-0381BX	Evaporator Coil with Distributor Assembly	X					
2	917-0382BX	Evaporator Coil – Coated with Distributor Assembly	X					
2	917-0353BX	Evaporator Coil with Distributor Assembly		X	X	X	X	X
2	917-0354BX	Evaporator Coil – Coated with Distributor Assembly		X	X	X	X	X
3	800-0458	Distributor Assembly	X					
3	800-0481	Distributor Assembly		X	X	X	X	X
4	1171-023	1/4" Receptacle	X	X	X	X	X	X
5	1171-024	1/4" Turn Retainer	X	X	X	X	X	X
6	1171-022	1/4" Turn Fastener	X	X	X	X	X	X
7	8103-028	Condenser Motor	X	X	X		X	X
7	8103-030	Condenser Motor				X		
8	8200-001	Fan Motor Mount	X	X	X	X	X	X
8	8200-050 ①	Stainless Steel Fan Motor Mount	X	X	X	X	X	X
9	5151-033	Fan Blade	X	X	X		X	X
9	5151C003 ①	Coated Fan Blade	X	X	X		X	X
9	5151-046	Fan Blade				X		
9	5151C046 ①	Coated Fan Blade				X		
10	CMC-31	Dirty Filter Switch Kit	X	X	X	X	X	X
11	CMA-37	Modulating Low Ambient Control (Screw On) ②	X	X	X		X	X
11	CMA-38	460V Modulating Low Ambient Control ②				X		
12	8000-433	Compressor	X					
12	8000-434	Compressor		X				
12	8000-435	Compressor			X			
12	8000-436	Compressor				X		X
12	8000-437	Compressor					X	
13	5051-205BX	Condenser Coil	X					
13	5054-205BX	Condenser Coil – Coated	X					
13	5051-204BX	Condenser Coil		X	X	X	X	X
13	5054-204BX	Condenser Coil – Coated		X	X	X	X	X
14	7004-011	Air Filter 1" Throw-Away (16x25x1)	X	X	X	X	X	X
14	7003-032	Air Filter 1" Washable ② (16x25x1)	X	X	X	X	X	X
14	7004-025	Air Filter 2" Pleated ② (16x25x2)	X	X	X	X	X	X
14	7004-059	Air Filter 2" Pleated – MERV 11 ② (16x25x2)	X	X	X	X	X	X
14	7004-061	Air Filter 2" Pleated – MERV 13 ② (16x25x2)	X	X	X	X	X	X
NS	8406-142	High Pressure Switch (Screw On)	X	X	X	X	X	X
NS	8406-140	Low Pressure Switch (Screw On)	X	X	X	X	X	X
NS	5201-021	Filter Drier	X	X	X	X	X	X
NS	5451-024	Tubing Isolation Grommet	X	X	X	X	X	X
NS	6031-009	Coremax Value Core	X	X	X	X	X	X
NS	1171-070	Filter Door Clip	2	2	2	2	2	2
NS	1171-068	Filter Door Screw	2	2	2	2	2	2
NS	1171-069	Filter Door Screw Retainer	2	2	2	2	2	2

NS – Not Shown

① – Used with stainless steel cabinet option

② – Optional on these models

# CONTROL PANEL

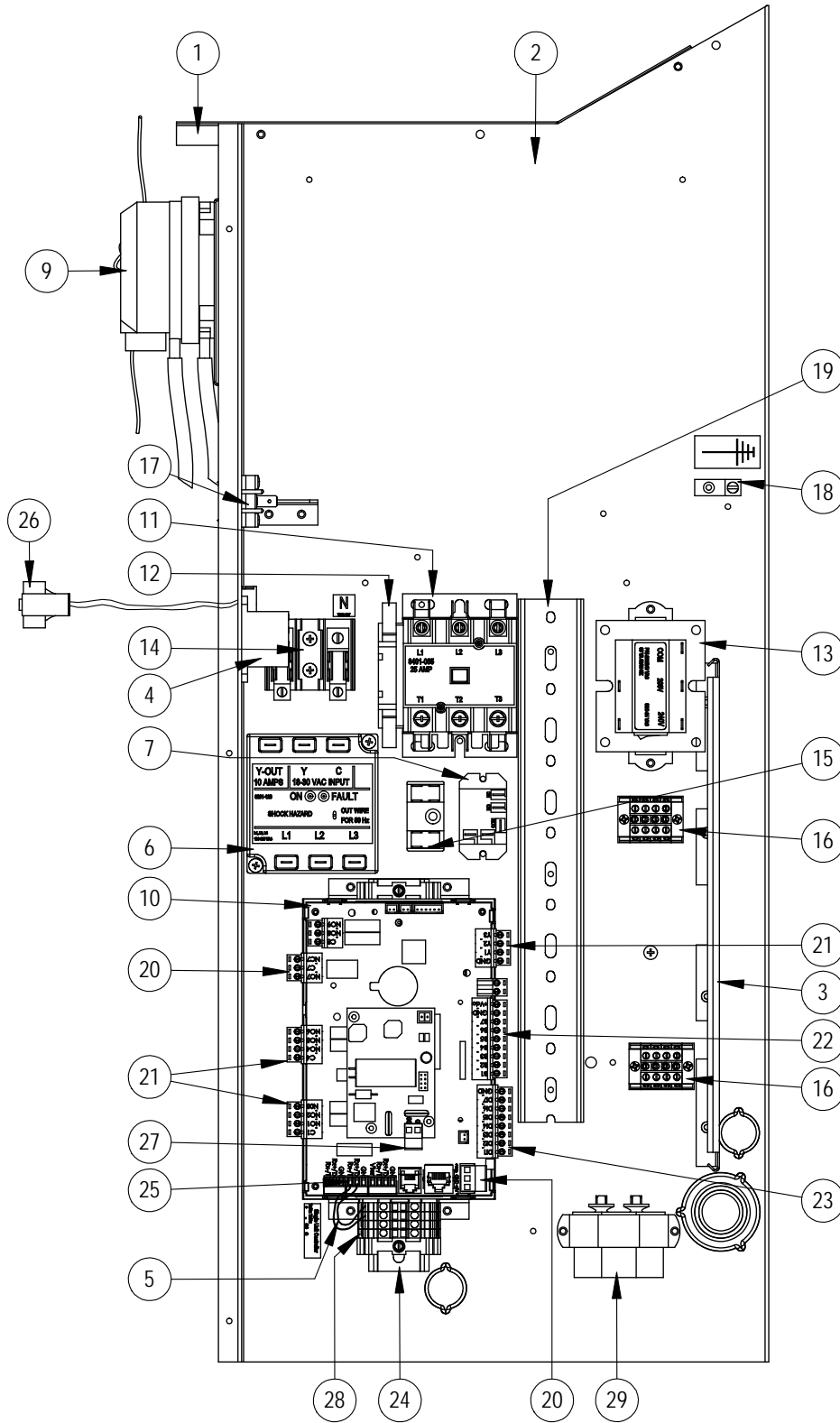

SEXP-880 B

# CONTROL PANEL

Dwg No.	Part Number	Description	W18ABPA	W24ABPA	W24ABPB	W24ABPC	W24ABPD	W24ABPF
1	117X137	Control Panel Top	X	X	X	X	X	X
2	117X395	Control Panel	X	X	X	X	X	X
3	135-122	Wire Shield	X	X	X	X	X	X
4	8201-130	Blower Relay	X	X	X	X	X	X
5	3020-004	Communications Sheathed Cable	X	X	X	X	X	X
6	8201-126	3 Phase Line Monitor 50/60 Hz			X	X		X
7	8201-130	Alarm Relay	X	X	X	X	X	X
8	8201-171BX	Compressor Control Module	X	X	X	X	X	X
9	8301-057	Filter Switch w/Adjustment	X	X	X	X	X	X
10	8301-096-001*	UPC3-C2 MULTI-TEC	X	X	X	X	X	X
11	8401-035	Contactor 3-Pole 25 Amp			X	X		X
11	8401-038	Contactor 2-Pole 40 Amp	X	X			X	
12	8401-039	Aux. NC Contact			X	X		X
13	8407-048	Transformer 208/240-24 75VA	X	X	X		X	X
13	8407-050	Transformer 480/24VAC 75VA				X		
14	8607-013	Terminal Block 2 Term. 240V						X
15	8607-017	Terminal Block 240V 2 Terminal	X	X	X	X	X	X
16	8607-037	Terminal Block 4 Position	X	X	X	X	X	X
17	8607-041	Park Terminal	X	X	X		X	X
18	8611-006	Ground Terminal	X	X	X	X	X	X
19	8611-140-1200	2-1/4" x 1" Cable Duct x 12"	X	X	X	X	X	X
20	8611-147	3-Pin Circuit Board Connector	X	X	X	X	X	X
21	8611-148	4-Pin Circuit Board Connector	X	X	X	X	X	X
22	8611-149	9-Pin Circuit Board Connector	X	X	X	X	X	X
23	8611-185	8-Pin Circuit Board Connector	X	X	X	X	X	X
24	8611-189	35MM DIN Rail 9"	X	X	X	X	X	X
25	8611-192	Small 3-Pin Circuit Board Connector	X	X	X	X	X	X
26	910-1935	Evap. Temp. Sensor Assembly	X	X	X	X	X	X
27	8611-183	2-Pin Circuit Board Connector	X	X	X	X	X	X
28	8611-150	DIN Rail Terminal Block	X	X	X	X	X	X
29	8552-046	Compressor Capacitor	X					
29	8552-051	Compressor Capacitor		X			X	
29	8552-002	Outdoor Motor Capacitor			X	X		X
NS	3000-1224	Compressor Plug/Harness	X	X			X	
NS	3000-1231	Compressor Plug/Harness			X	X		X
NS	8615-035	Circuit Breaker 20A 2 Pole (Opt.) ①	X				X	
NS	8615-036	Circuit Breaker 25A 2 Pole (Opt.) ①		X				
NS	8615-056	Circuit Breaker 15A 3 Pole (Opt.) ①			X			
NS	8615-067	Toggle Disconnect (Opt.) ①				X		X
NS	4207-107	Wiring Diagram	X					
NS	4207-108	Wiring Diagram		X			X	
NS	4207-207	Wiring Diagram			X			
NS	4207-308	Wiring Diagram				X		
NS	4207-602	Wiring Diagram						X
NS	8301-075	USB Micro Cable Female to Male	X	X	X	X	X	X

\* Replacement part will have a letter attached to the end of the part number to designate software version (Example: 8301-096-001**A**). A software upgrade of all PLCs onsite (units and controllers) should accompany any PLC replacement. Latest revisions of software, change log and instructions are available on the Bard website at <http://www.bardhvac.com/software-download/>

① Circuit breakers listed are for units without electric heat, "OZ" models. Hot gas bypass models not available without electric heat. See heater replacement parts manual for units with electric heat.

NS = Not Shown

# BLOWER ASSEMBLY

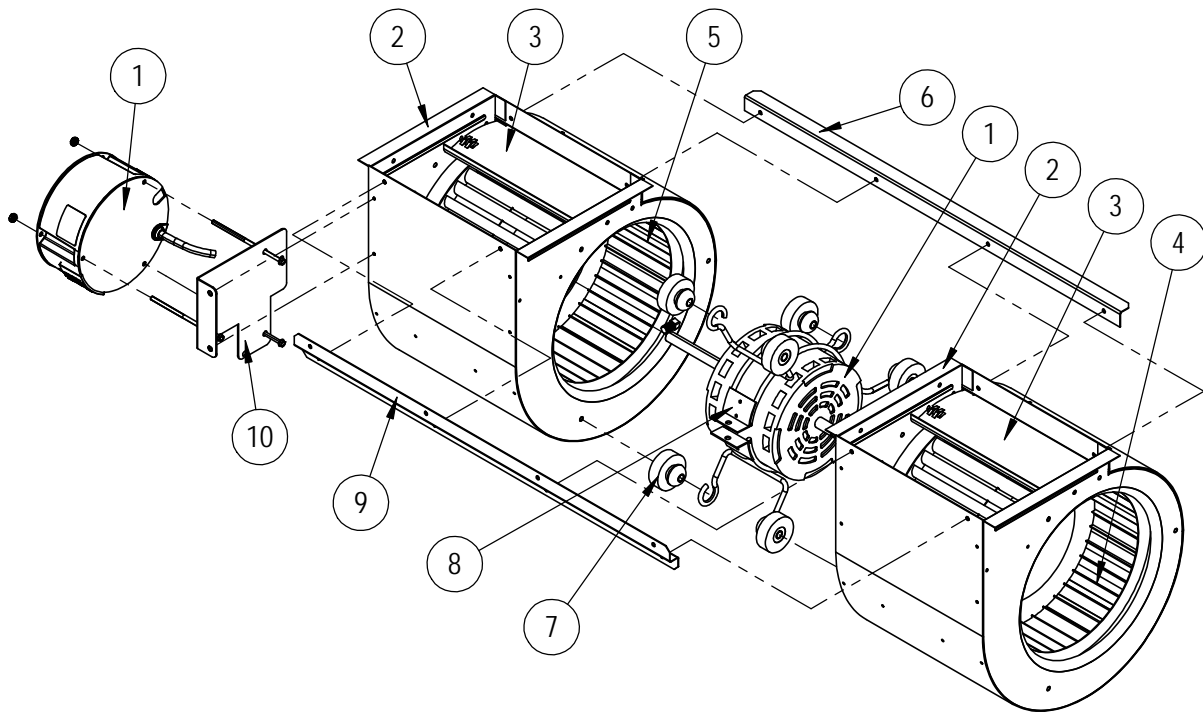

SEXP-909

Dwg No.	Part Number	Description	S900-358-001	S900-358-002	S900-359-001
1	S8105-064-0147	Programmed Blower Motor & Control (230/208V)	X		
1	S8105-064-0148	Programmed Blower Motor & Control (230/208V)		X	
1	S8105-065-0149	Programmed Blower Motor & Control (460V)			X
1	C8105-064-0147	Programmed Control Only (230/208V)	0		
1	C8105-064-0148	Programmed Control Only (230/208V)		0	
1	C8105-065-0149	Programmed Control Only (460V)			0
2	151-115	Housing	2	2	2
3	144-183	Cutoff	X	X	X
4	5152-092	Wheel 9-6 CW	X	X	X
5	5152-093	Wheel 9-6 CCW	X	X	X
6	105-1061	Back Brace	X	X	X
7	5451-011	Grommets	6	6	6
8	8200-031	Motor Mount	X	X	X
9	103-435	Front Brace	X	X	X
10	113-721	Motor Control Bracket	X	X	X



# FREECOOLING COMPONENTS

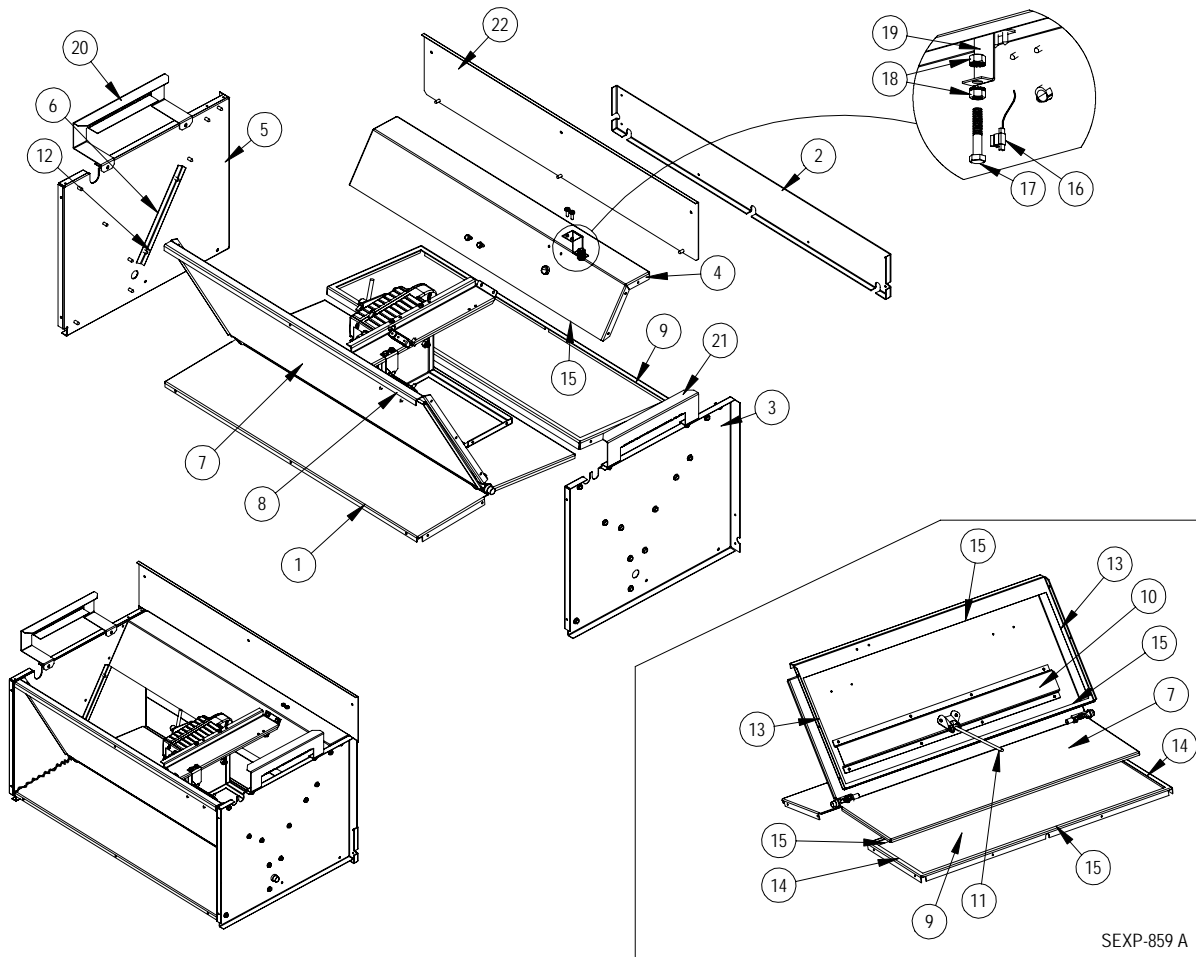

SEXP-859 A

Dwg. No.	Part Number	Description
1	137-742	Lower Front Partition
2	137-747	Lower Rear Fill
3	S101-979	Right Side
4	S137-876	Upper Rear Partition
5	S101-978	Left Side
6	S105-1344	Blade Seal Angle
7	S139-325	Blade
8	S137-866	Upper Front Partition
9	S137-744	Lower Rear Partition
10	141-433	Blade Support
11	8602-044	1/4 x 9" Rod
12	S1921-067-0800	29-9/16" Damper Blade Seal
13	S1921-067-1004	13" Damper Blade Seal
14	S1921-067-0802	10-11/16" Damper Blade Seal
15	S1921-067-2010	29-3/8" Damper Blade Seal
16	8408-044	Sensor 10K Ohm Curve J w/ 5/16" Clip
17	1012-052	Hex Head Bolt 5/16 - 18x1-3/4" 0.0005 Zinc w/ Yellow Chromate
18	1012-210	5/16" Nut 0.0005 Zinc w/ Yellow Chromate
19	113-541	Sensor Bracket
20	113-542	Filter Bracket
21	113-543	Filter Bracket
22	137-748	Upper Rear Fill
23	8602-040	Rod Bracket
NS	536-664	Condenser Cover Plate Assembly

# FREECOOLING AIR HOOD

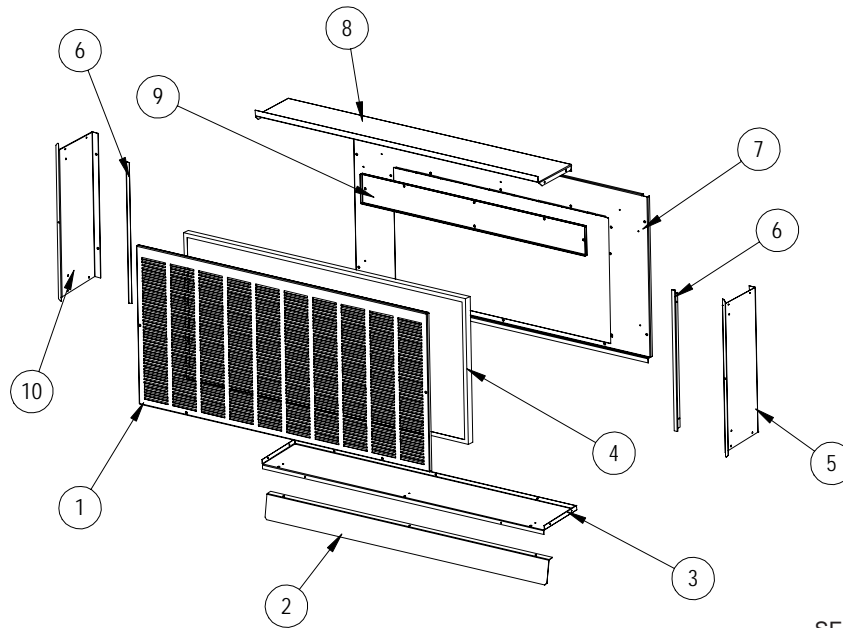

SEXP-752A

Dwg. No.	Part Number	Description
1	115-285-* ①	Hooded Front Door
1	115-292 ②	Hooded Front Door
1	115-293 ③	Hooded Front Door
2	113-545-* ①	Bottom Divider Bracket
2	113-569 ②	Bottom Divider Bracket
2	113-570 ③	Bottom Divider Bracket
3	S127-494-* ①	Hood Bottom
3	S127-563 ②	Hood Bottom
3	S127-503 ③	Hood Bottom
4	7003-080	Mist Filter 31-1/4" x 15-7/8" x 7/8"
5	S101-984-* ①	Right Side
5	S101-1033 ②	Right Side
5	S101-1013 ③	Right Side
6	105-1346	Side Filter Angle
6	105-1346 ②	Side Filter Angle
6	105-1370 ③	Side Filter Angle
7	553-667-* ①	Hood Mounting Door
7	553-711 ②	Hood Mounting Door
7	553-702 ③	Hood Mounting Door
8	S107-345-* ①	Hood Top
8	S107-355 ②	Hood Top
8	S107-356 ③	Hood Top
9	553-613	Filter Door
9	553-634 ②	Filter Door
9	553-631 ③	Filter Door
10	S101-873-* ①	Left Side
10	S101-997 ②	Left Side
10	S101-882 ③	Left Side
	920-0390	Complete Hood Assembly - Beige
	920-0391	Complete Hood Assembly - White
	920-0392	Complete Hood Assembly - Buckeye Gray
	920-0421	Complete Hood Assembly - Stainless Steel
	920-0408	Complete Hood Assembly - Aluminum

① Exterior cabinet parts are manufactured with various paint color options. To ensure the proper paint color is received, reference the following codes:

Beige -X      Buckeye Gray -4      White -1

② Exterior cabinet parts are manufactured from stainless steel Code "S"

③ Exterior cabinet parts are manufactured from aluminum Code "A"

# FREECOOLING DAMPER MOTOR

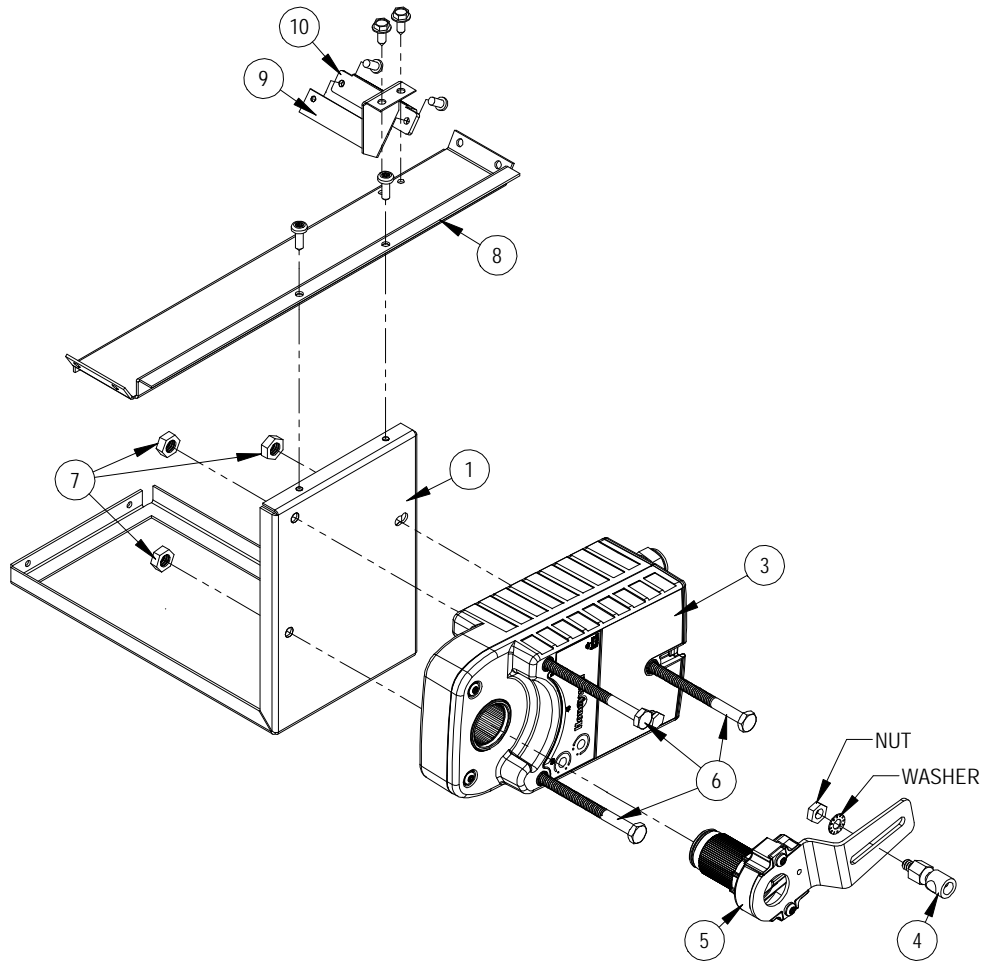

SEXP-879

Dwg. No.	Part Number	Description
1	141-466	Actuator Support Plate
3	8602-067	Direct Coupled Actuator
4	8602-008	Ball Joint
5	8602-068	Belimo Actuator Crank Arm 1/2"
6	1012-174	1/4" - 20x3 - 1/4 Hex Cap Screws
7	1012-201	1/4-20 Steel Keps Hex Nut Zinc
8	141-464	Actuator Support Bar
9	113-655	Blade Switch Bracket
10	8406-150	Lever Switch SPDT Sealed Pilot Duty
11	1012-178	4-40 x 5/8" Phillips Pan Head Machine Screw, Zinc Plated
12	1012-231	4-40 Steel Keps Hex Nut Zinc
NS	910-2014	Outdoor Temperature Sensor