

---

# REPLACEMENT PARTS MANUAL

---

## Wall Mount Air Conditioner

Models:

J42AC-A   J48AC-A   J60AC-A   J72AC-A  
J42AC-B   J48AC-B   J60AC-B   J72AC-B  
J42AC-C   J48AC-C   J60AC-C   J72AC-C

---

### Contents

Description	Page
External Parts	
♦ Exploded View .....	2
♦ Usage List .....	3
Internal Parts	
♦ Exploded View .....	4
♦ Usage List .....	5
Functional Components	
♦ Exploded View .....	6
♦ Usage List .....	7
Control Panel	
♦ Layout View .....	8
♦ Usage List .....	9
Blower Assembly	
♦ Exploded View .....	10
♦ Usage List .....	10

### General Notes

- Revised and/or additional pages may be issued from time to time.
- A complete and current manual consists of pages shown in the following contents section.

### Important

- Contact the installing and/or local distributor for all parts requirements. Make sure you have the complete model and serial number available from the unit rating plates.



Manual: 2110-1463A  
Supersedes: 2110-1463  
Date: 10-23-19

# EXTERNAL PARTS

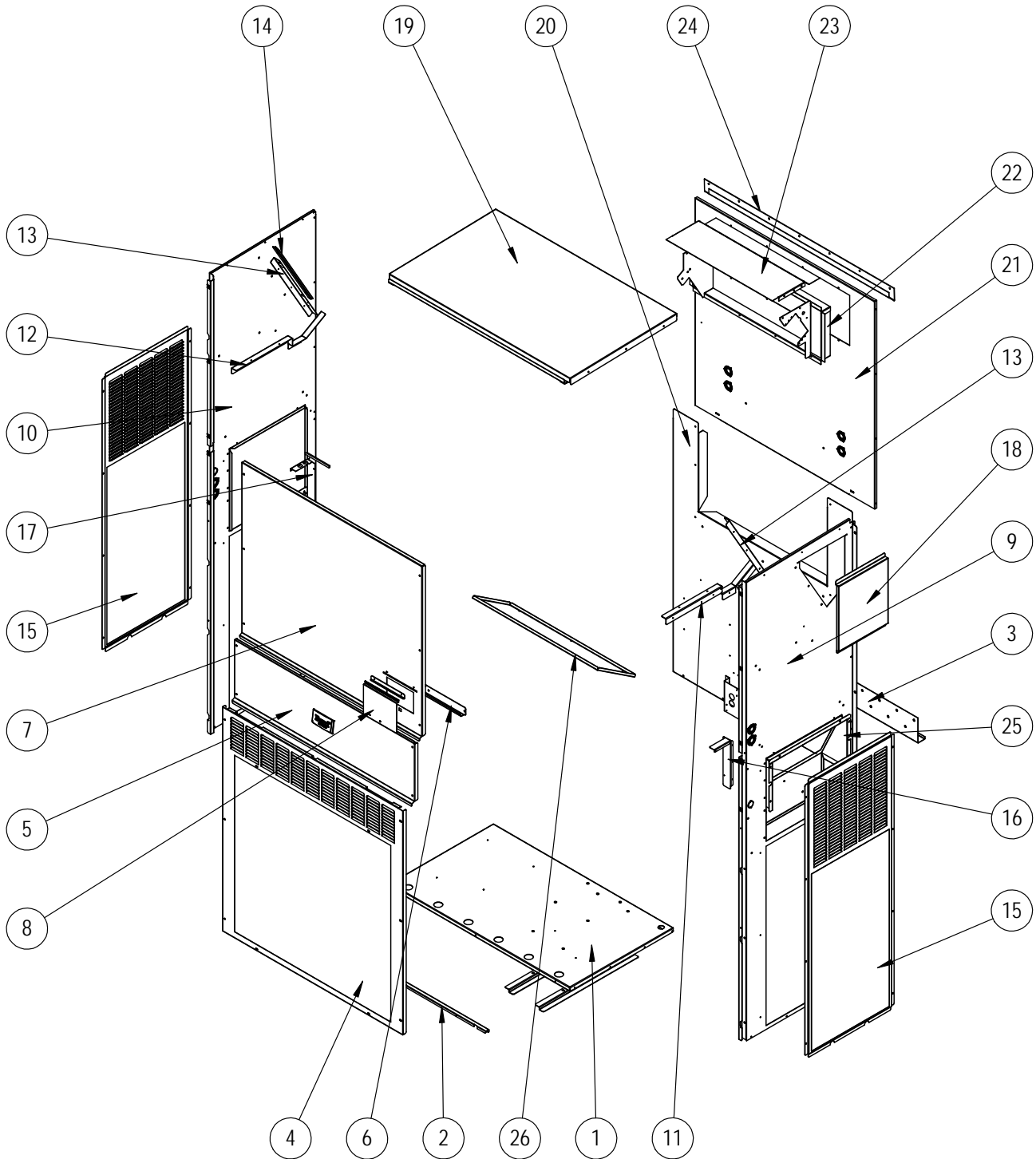

SEXP-932

## EXTERNAL PARTS

Dwg No.	Part Number	Description	J42AC-A, B, C	J48AC-A, B, C	J60AC-A, B, C	J72AC-A, B, C
1	S127-574	Unit Base	X	X	X	X
2	113-762	Front Base Bracket	X	X	X	X
3	113-140	Bottom Mounting Bracket	X	X	X	X
4	119-125-X	Front Grille	X	X		
4	119-127-X	Front Grille			X	X
5	S533-301-X	Control Panel Cover (Outer)	X	X	X	X
6	S165-608-X	Rain Channel	X	X	X	X
7	S515-323-X	Upper Front	X	X		
7	S515-324-X	Upper Front			X	X
8	153-717-X	Disconnect Access Door	X	X	X	X
9	S501-1053-X	Right Side	X	X		
9	S501-1055-X	Right Side			X	X
10	501-1054-X	Left Side	X	X		
10	501-1056-X	Left Side			X	X
11	105X1454	Right Support Angle	X	X	X	X
12	105Y1454	Left Support Angle	X	X	X	X
13	105-1457	Coil Support	2	2		
13	105-1455	Coil Support			2	2
14	147-055	Coil Support Offset	X	X		
14	147-054	Coil Support Offset			X	X
15	119-126-X	Side Grille	2	2		
15	119-128-X	Side Grille			2	2
16	105-1450	Right Control Panel Angle	X	X	X	X
17	105-1451	Left Control Panel Angle	X	X	X	X
18	S543-221-X	Heater Access Cover	X	X	X	X
19	507-382-X	Top	X	X	X	X
20	109-412	Lower Back	X	X		
20	109-414	Lower Back			X	X
21	S509-411	Upper Back	X	X		
21	S509-413	Upper Back			X	X
22	S111-299	Outlet Air Frame Assembly	X	X	X	X
23	535-129	Heat Shield	X	X	X	X
24	113-150-X	Top Rain Flashing	X	X	X	X
25	539-406	Fresh Air Damper Assembly	X	X	X	X
26	543-220	Exhaust Blank Off Plate	X	X	X	X

# INTERNAL PARTS

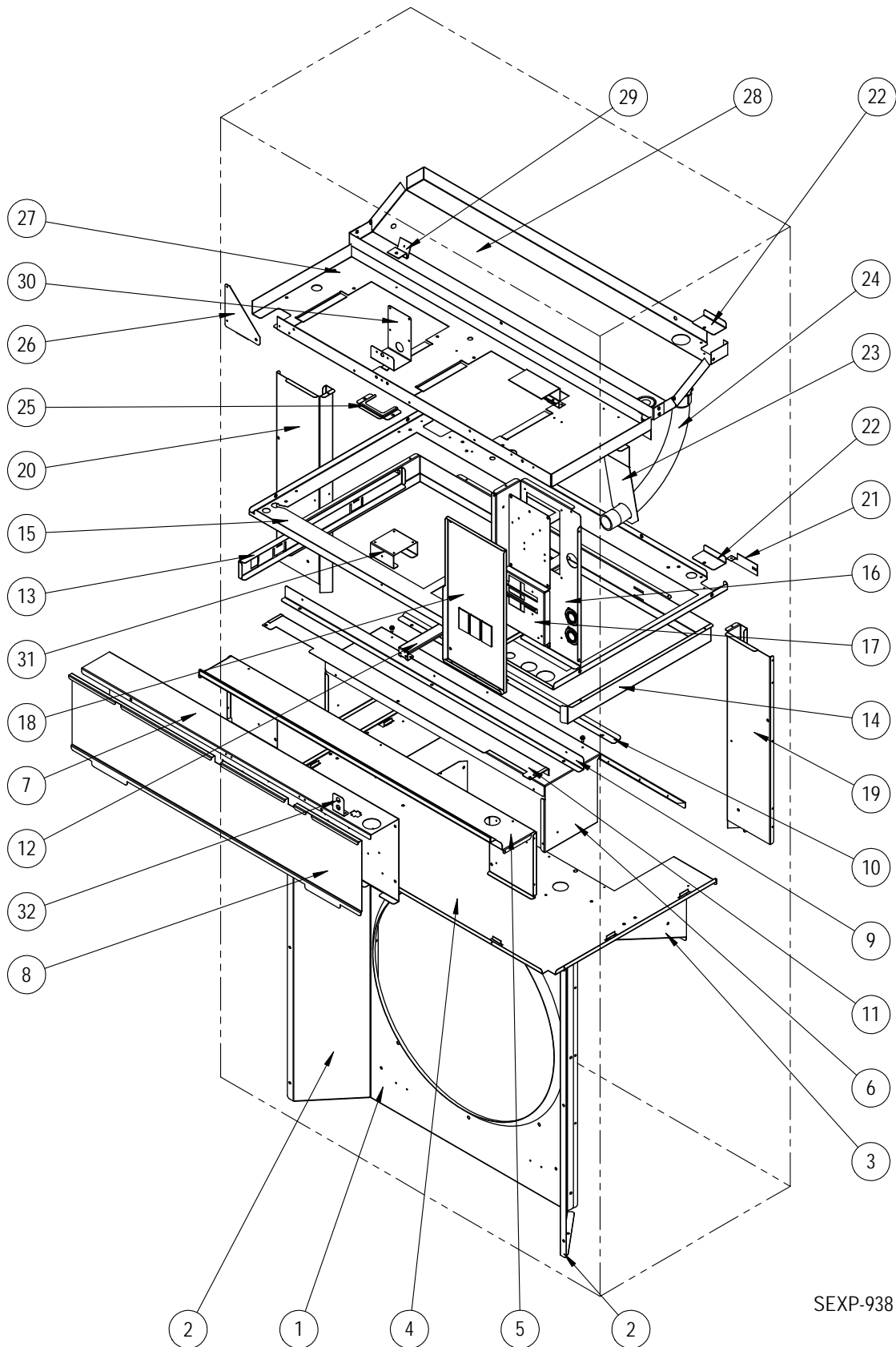

SEXP-938

# INTERNAL PARTS

Dwg No.	Part Number	Description	J42AC-A, B	J42AC-C	J48AC-A, B	J48AC-C	J60AC-A, B	J60AC-C	J72AC-A, B	J72AC-C
1	125-089	Fan Shroud	X	X	X	X				
1	125-091	Fan Shroud					X	X	X	X
2	S125-090	Fan Shroud Side Access Cover	2	2	2	2				
2	S125-092	Fan Shroud Side Access Cover					2	2	2	2
3	121-586	Condenser Partition Insert	X	X	X	X	X	X	X	X
4	121-585	Condenser Partition	X	X	X	X	X	X	X	X
5	521-584	Front Exhaust Partition	X	X	X	X	X	X	X	X
6	521-587	Exhaust Partition	X	X	X	X	X	X	X	X
7	Control Panel Assy.	See Control Panel Assy. Drawing & Parts List	X	X	X	X	X	X	X	X
8	S133-302	Control Panel Cover (Inner)	X	X	X	X	X	X	X	X
9	105-1453	Front Vent Guide Rail	X	X	X	X	X	X	X	X
10	105-1452	Vent Guide Rail	X	X	X	X	X	X	X	X
11	S135-392	Field Wire Shield	X	X	X	X	X	X	X	X
12	131-168	Filter Support Bracket	2	2	2	2	2	2	2	2
13	131-170	Filter Slide	X	X	X	X	X	X	X	X
14	131-169	Filter Rack Frame	X	X	X	X	X	X	X	X
15	121-583	Filter Partition	X	X	X	X	X	X	X	X
16	117-412	Upper Control Panel	X	X	X	X	X	X	X	X
17	127-575	Circuit Breaker Base	X		X		X		X	
17	127-585	Circuit Breaker Base - 460V		X		X		X		X
18	S133-303	Upper Control Panel Cover	X		X		X		X	
18	S133-304	Upper Control Panel Cover - 460V		X		X		X		X
19	135X393	Right Copper Chase	X	X	X	X	X	X	X	X
20	135Y393	Left Copper Chase	X	X	X	X	X	X	X	X
21	113-796	Copper Retainer	2	2	2	2	2	2	2	2
22	137-920	Copper Fill Plate	2	2	2	2	2	2	2	2
23	113-766	Conduit Bracket	X	X	X	X	X	X	X	X
24	8611-235	Conduit Elbow	X	X	X	X	X	X	X	X
25	113-765	Grommet Retainer	X	X	X	X	X	X	X	X
26	141-492	Blower Partition Support	X	X	X	X	X	X	X	X
27	121-582	Blower Partition	X	X	X	X	X	X	X	X
28	523-161	Drain Pan	X	X	X	X	X	X	X	X
29	113-768	EEV mounting Bracket	X	X	X	X	X	X	X	X

# FUNCTIONAL COMPONENTS

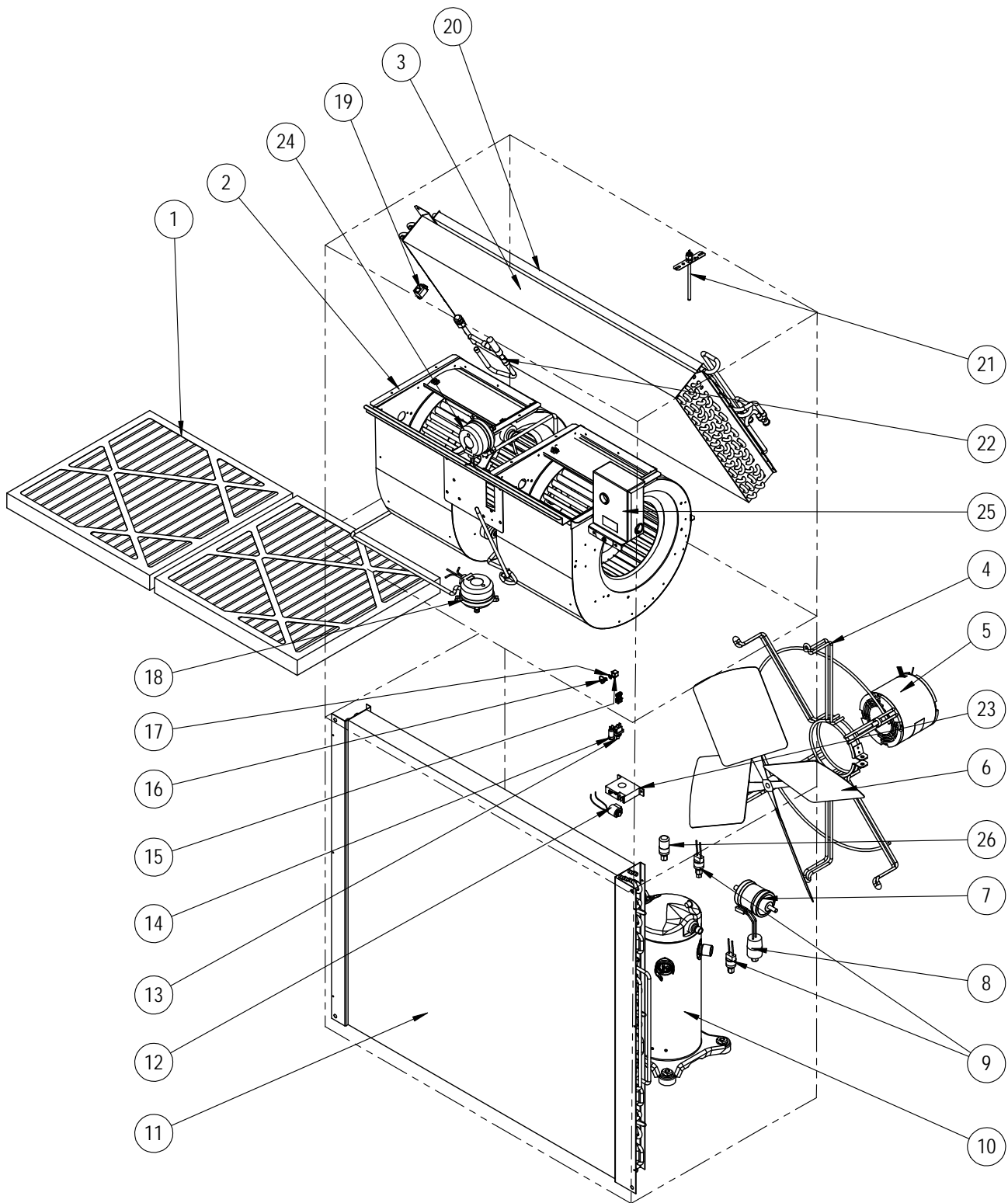

SEXP-931

# FUNCTIONAL COMPONENTS

Dwg No.	Part Number	Description	J42AC-A	J42AC-B	J42AC-C	J48AC-A	J48AC-B	J48AC-C	J60AC-A	J60AC-B	J60AC-C	J72AC-A	J72AC-B	J72AC-C
1	7004-052	Air Filter 2" Merv 8 (20 x 20 x 2)	2	2	2	2	2	2	2	2	2	2	2	2
2	S900-366-001	Blower Assembly	X	X										
2	S900-367-001	Blower Assembly - 460V			X									
2	S900-368-001	Blower Assembly				X	X							
2	S900-369-001	Blower Assembly - 460V						X						
2	S900-368-002	Blower Assembly							X	X				
2	S900-369-002	Blower Assembly - 460V									X			
2	S900-368-003	Blower Assembly										X	X	
2	S900-369-003	Blower Assembly - 460V												X
3	917-0366BX	Evaporator Coil w/Distributor Assy.	X	X	X									
3	917-0370BX	Evaporator Coil w/Distributor Assy.				X	X	X						
3	917-0374BX	Evaporator Coil w/Distributor Assy.							X	X	X			
3	917-0378BX	Evaporator Coil w/Distributor Assy.										X	X	X
4	8200-004	Fan Motor Mount	X	X	X	X	X	X	X	X	X			
4	8200-049	Fan Motor Mount										X	X	X
5	8105-068	Condenser Motor	X	X		X	X		X	X				
5	8105-071	Condenser Motor - 460V			X			X			X			
5	8106-070	Condenser Motor										X	X	
5	8106-071	Condenser Motor - 460V												X
6	5151-060	Fan Blade	X	X	X	X	X	X	X	X	X			
6	5151-063	Fan Blade										X	X	X
7	5201-022	Filter Drier	X	X	X	X	X	X	X	X	X	X	X	X
8	CMA-39	Low Ambient Control (LAC)	O	O	O	O	O	O	O	O	O	O	O	O
9	8406-142	High Pressure Switch	X	X	X	X	X	X	X	X	X	X	X	X
9	8406-140	Low Pressure Switch	X	X	X	X	X	X	X	X	X	X	X	X
10	8000-349	Compressor	X											
10	8000-350	Compressor		X										
10	8000-351	Compressor			X									
10	8000-332	Compressor				X								
10	8000-333	Compressor					X							
10	8000-334	Compressor						X						
10	8000-289	Compressor							X					
10	8000-292	Compressor								X				
10	8000-308	Compressor									X			
10	8000-403	Compressor										X		
10	8000-404	Compressor											X	
10	8000-405	Compressor												X
11	5051-222BX	Condenser Coil	X	X	X	X	X	X						
11	5051-223BX	Condenser Coil							X	X	X	X	X	X
15	1171-023	1/4 Turn Receptacle	X	X	X	X	X	X	X	X	X	X	X	X
16	1171-022	1/4 Turn Fastener	X	X	X	X	X	X	X	X	X	X	X	X
17	1171-024	1/4 Turn Retainer	X	X	X	X	X	X	X	X	X	X	X	X
22	800-0482	Distributor Assembly	X	X	X									
22	800-0483	Distributor Assembly				X	X	X						
22	800-0484	Distributor Assembly							X	X	X			
22	800-0454	Distributor Assembly										X	X	X
NS	5451-024	Tubing Isolation Grommet	2	2	2	2	2	2	2	2	2	2	2	2
NS	6031-009	Coremax Valve Core	2	2	2	2	2	2	2	2	2	2	2	2
NS	1171-028	Control Panel Door Clip	4	4	4	4	4	4	4	4	4	4	4	4
NS	1171-057	Control Panel Door Screw	4	4	4	4	4	4	4	4	4	4	4	4
NS	1171-027	Control Panel Door Screw Retainer	4	4	4	4	4	4	4	4	4	4	4	4

NS – Not Shown

X – Standard Component

O – Optional Component

# CONTROL PANEL

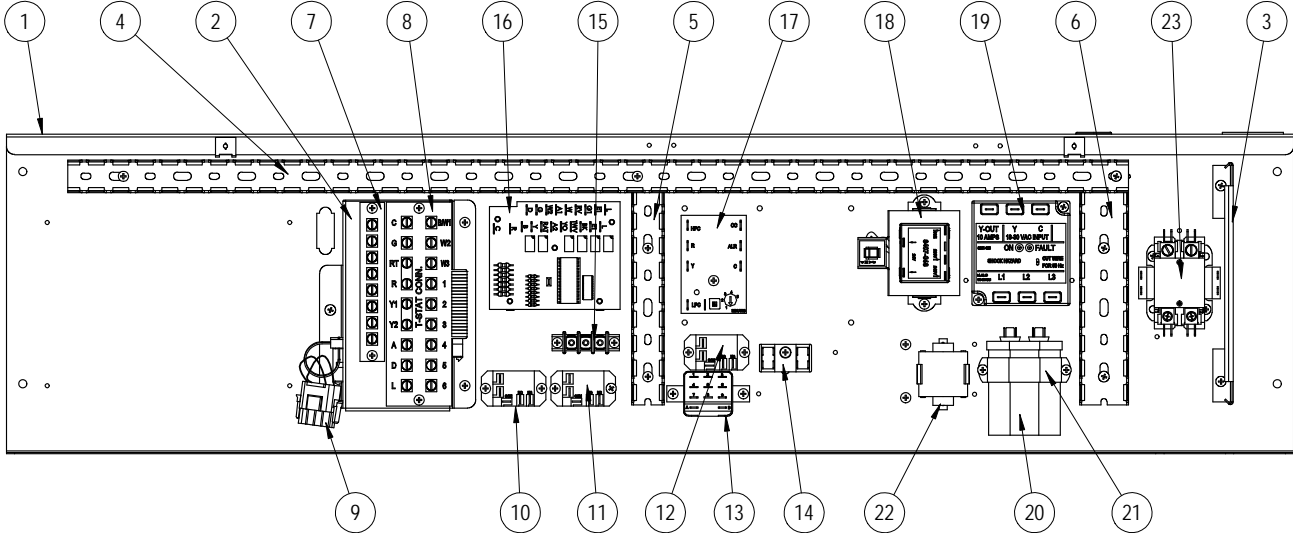

SEXP-928



# CONTROL PANEL

Dwg No.	Part Number	Description	J42AC-A	J42AC-B	J42AC-C	J48AC-A	J48AC-B	J48AC-C	J60AC-A	J60AC-B	J60AC-C	J72AC-A	J72AC-B	J72AC-C
1	117-411	Control Panel	X	X	X	X	X	X	X	X	X	X	X	X
2	S910-2061	Complete Low Voltage Box Assembly (Sheet metal, Terminal Strip, & Wire Harness)	X	X	X	X	X	X	X	X	X	X	X	X
3	135-394	Wire Shield	X	X	X	X	X	X	X	X	X	X	X	X
4	8611-140-3208	Cable Duct - 32.5"	X	X	X	X	X	X	X	X	X	X	X	X
5	8611-140-0608	Cable Duct - 6.5" x 1" wide	X	X	X	X	X	X	X	X	X	X	X	X
6	8611-244-0608	Cable Duct - 6.5" x 1.5" wide	X	X	X	X	X	X	X	X	X	X	X	X
8	8607-063	Low Voltage Terminal Strip - 18 term.	X	X	X	X	X	X	X	X	X	X	X	X
9	3000-1524	Vent Jumper Plug (used when no vent option)	X	X	X	X	X	X	X	X	X	X	X	X
11	8201-130	Blower Speed Relay	X	X	X	X	X	X	X	X	X	X	X	X
14	8607-017	Terminal Block (LAC Kit = CMA-39)	O	O	O	O	O	O	O	O	O	O	O	O
15	8607-042	Blower Speed Terminal Block	X	X	X	X	X	X	X	X	X	X	X	X
17	8201-164	Compressor Control Module	X	X	X	X	X	X	X	X	X	X	X	X
18	8407-068	Transformer	X	X		X	X	X	X	X		X	X	
18	8407-069	Transformer			X			X			X			X
19	8201-126	Phase Monitor		X	X		X	X		X	X		X	X
20	8552-079	Compressor Capacitor	X			X			X					
20	8552-089	Compressor Capacitor										X		
20	8552-097	Compressor Capacitor												
20	8552-005	Outdoor Motor Capacitor		X			X			X				X
20	8552-004	Outdoor Motor Capacitor			X			X			X		X	
21	8550-008	Capacitor Strap	X			X			X			X		
21	8550-003	Capacitor Strap		X	X		X	X		X	X		X	X
22	8551-004	Start Device (PTCR)	O	O	O	O	O	O	O	O	O	O	O	O
23	8401-034	Compressor Contactor	X			X			X			X		
23	8401-035	Compressor Contactor		X	X		X	X		X	X		X	X
NS	8615-040	Circuit Breaker 50A 2 Pole ①	O			O			O			O		
NS	8615-041	Circuit Breaker 60A 2 Pole ①												
NS	8615-042	Circuit Breaker 35A 3 Pole ①		O			O							
NS	8615-043	Circuit Breaker 40A 3 Pole ①								O				
NS	8615-045	Circuit Breaker 50A 3 Pole ①											O	
NS	S8615-067	Toggle Disconnect			O			O			O			O
NS	4095-196	Wiring Diagram	X			X			X			X		
NS	4095-296	Wiring Diagram		X			X			X			X	
NS	4095-378	Wiring Diagram			X			X			X			X
NS	3000-1613	Blower Power Plug	X	X	X	X	X	X	X	X	X	X	X	X
NS	3000-1614	Blower Speed Plug	X	X	X	X	X	X	X	X	X	X	X	X
NS	3000-1222	Compressor Plug/Harness	X			X			X			X		
NS	3000-1230	Compressor Plug/Harness		X	X		X	X		X	X		X	X
NS	3003-053	Control Panel Wire Harness	X			X			X			X		
NS	3003-055	Control Panel Wire Harness		X	X		X	X		X	X		X	X
NS	3000-1608	Low Voltage Terminal Block Wire Harness	X	X	X	X	X	X	X	X	X	X	X	X

NS = Not Shown

X – Standard Component

① Circuit breakers listed are for units without electric heat, "0Z" models. See heater replacement parts manual for units with electric heat.

O – Optional Component

# BLOWER ASSEMBLY

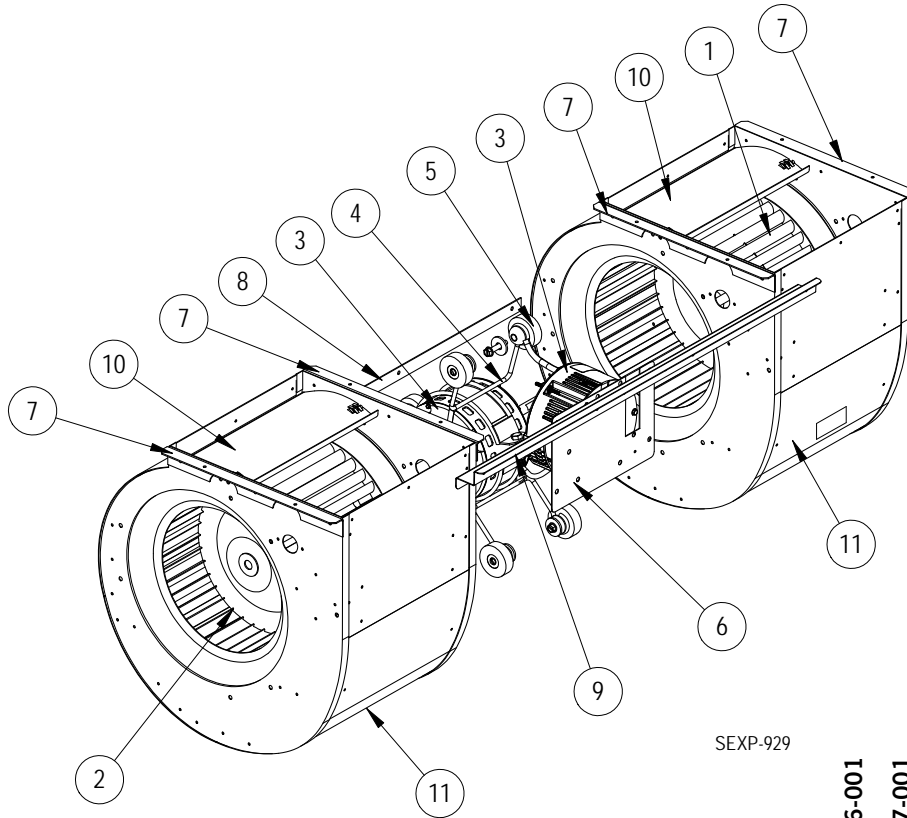

SEXP-929

Dwg No.	Part Number	Description	S900-366-001	S900-367-001	S900-368-001	S900-368-002	S900-368-003	S900-369-001	S900-369-002	S900-369-003
1	5152-011	10 Inch Wheel (CW)	X	X	X	X	X	X	X	X
2	5152-012	10 Inch Wheel (CW)	X	X	X	X	X	X	X	X
3	S8106-068-0155	Programmed Blower Motor & Control (230/208V)	X							
3	S8106-069-0156	Programmed Blower Motor & Control (460V)		X						
3	S8107-028-0157	Programmed Blower Motor & Control (230/208V)			X					
3	S8107-028-0159	Programmed Blower Motor & Control (230/208V)				X				
3	S8107-028-0161	Programmed Blower Motor & Control (230/208V)					X			
3	S8107-029-0158	Programmed Blower Motor & Control (460V)						X		
3	S8107-029-0160	Programmed Blower Motor & Control (460V)							X	
3	S8107-029-0162	Programmed Blower Motor & Control (460V)								X
3	C8106-068-0155	Programmed Control Only (230/208V)	0							
3	C8106-069-0156	Programmed Control Only (460V)		0						
3	C8107-028-0157	Programmed Control Only (230/208V)			0					
3	C8107-028-0159	Programmed Control Only (230/208V)				0				
3	C8107-028-0161	Programmed Control Only (230/208V)					0			
3	C8107-029-0158	Programmed Control Only (460V)						0		
3	C8107-029-0160	Programmed Control Only (460V)							0	
3	C8107-029-0162	Programmed Control Only (460V)								0
4	8200-040	Motor Mount	X	X	X	X	X	X	X	X
5	5451-011	Grommets	6	6	6	6	6	6	6	6
6	112-775	Motor Control Bracket	X	X	X	X	X	X	X	X
7	105-880	Side Angle	4	4	4	4	4	4	4	4
8	105-881	Back Brace	X	X	X	X	X	X	X	X
9	103-541	Front Mounting Offset	X	X	X	X	X	X	X	X
10	144-166	Diffuser	2	2	2	2	2	2	2	2
11	151-101	Blower Housing	2	2	2	2	2	2	2	2