

REPLACEMENT PARTS MANUAL

MULTI-TEC® Wall Mount Air Conditioner

Models:

W42ACEA	W42ACPB	W48ACMA	W48ACPF	W60ACMC	W72ACEA	W72ACPB
W42ACEB	W42ACPC	W48ACMB	W48ACPQ	W60ACPA	W72ACEB	W72ACPC
W42ACEC	W42ACPE	W48ACMC	W60ACEA	W60ACPB	W72ACEC	W72ACPF
W42ACMA	W42ACPF	W48ACPA	W60ACEB	W60ACPC	W72ACMA	W72ACPQ
W42ACMB	W48ACEA	W48ACPB	W60ACEC	W60ACPE	W72ACMB	
W42ACMC	W48ACEB	W48ACPC	W60ACMA	W60ACPF	W72ACMC	
W42ACPA	W48ACEC	W48ACPE	W60ACMB	W60ACPQ	W72ACPA	

Contents

Description	Page
External Parts	
♦ Exploded View	2
♦ Usage List	3
♦ Usage List	4
Internal Parts	
♦ Exploded View	6
♦ Usage List	7
♦ Usage List	8
Functional Components	
♦ Exploded View	10
♦ Usage List	11
♦ Usage List	12
♦ Usage List	13
♦ Usage List	14
Control Panel	
♦ Layout View	16
♦ Usage List	17
♦ Usage List	18
♦ Usage List	19
♦ Usage List	20
Blower Assembly	
♦ Exploded View	21
♦ Usage List	21
Intake Blade Assembly	
♦ Exploded View	22
♦ Usage List	23

Description	Page
Actuator Assembly	
♦ Exploded View	24
♦ Usage List	25
Base Assembly and Exhaust Blade Assembly	
♦ Exploded View	26
♦ Usage List	27
Exhaust Partition Assy/Intake Seal Angle Assy	
♦ Exploded View	28
♦ Usage List	29
Vent Assembly	
♦ Exploded View	30
♦ Usage List	31

General Notes

- Revised and/or additional pages may be issued from time to time.
- A complete and current manual consists of pages shown in the following contents section.

Important

- Contact the installing and/or local Bard distributor for all parts requirements. Make sure to have the complete model and serial number available from the unit rating plates.



Bard Manufacturing Company, Inc.
 Bryan, Ohio 43506
 www.bardhvac.com

Manual: 2110-1464L
 Supersedes: 2110-1464K
 Date: 1-3-24

EXTERNAL PARTS

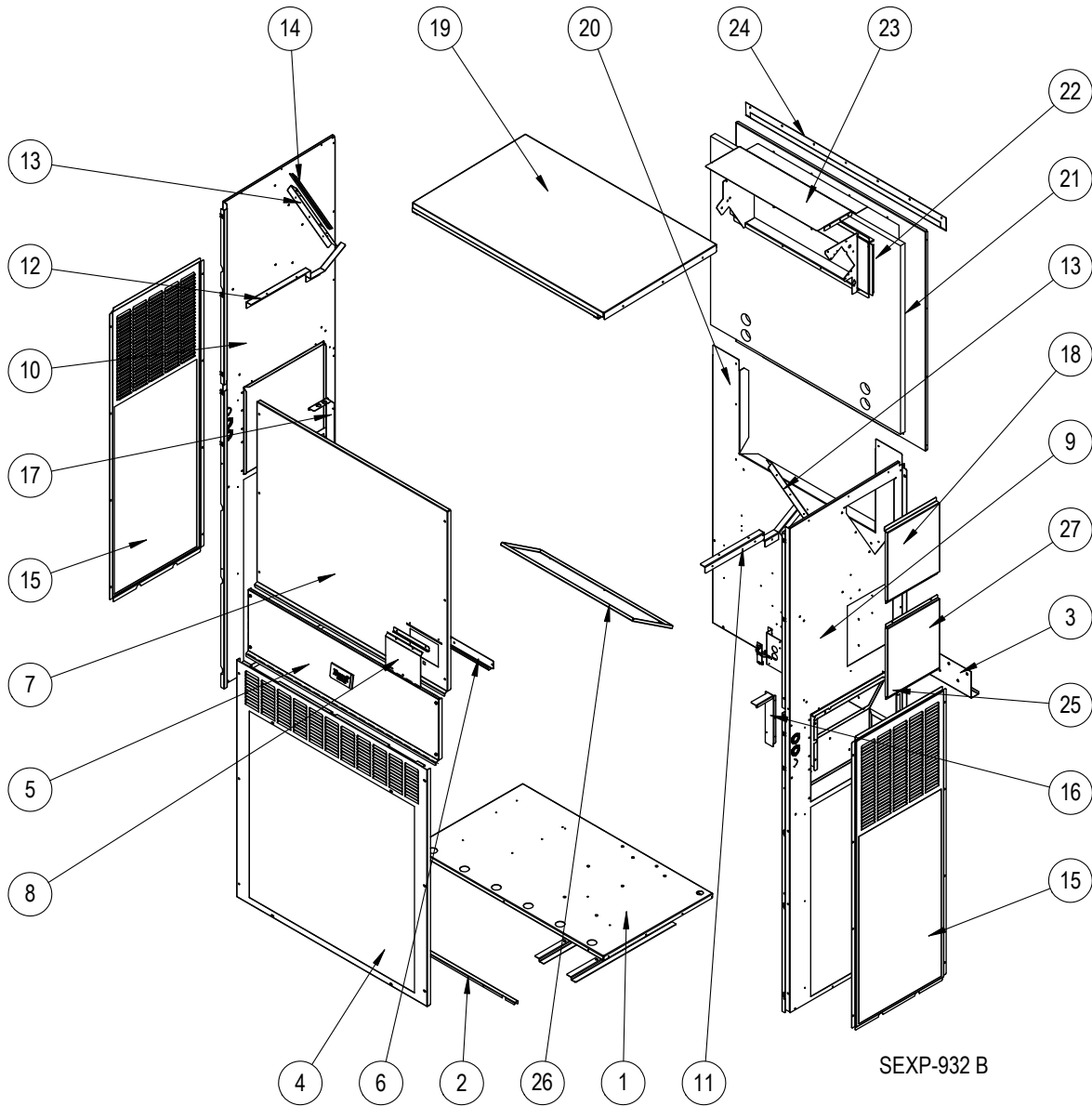

This drawing to be used for reference for pages 3 and 4

EXTERNAL PARTS – STANDARD & DEHUMIDIFICATION

Dwg No.	Part Number	Description	W42ACPA, B, C, E, F	W42ACMA, B, C	W42ACEA, B, C	W48ACPA, B, C, E, F, Q	W48ACMA, B, C	W48ACEA, B, C
1	S127-574	Unit Base	X	X	X	X	X	X
1	S127-584 ③	Unit Base	0	0	0	0	0	0
2	113-762	Front Base Bracket	X	X	X	X	X	X
2	113-797 ③	Front Base Bracket	0	0	0	0	0	0
3	113-140	Bottom Mounting Bracket	X	X	X	X	X	X
4	119-125-* ①	Front Grille	X	X	X	X	X	X
4	119-131 ②	Front Grille	0	0	0	0	0	0
4	119-135 ③	Front Grille	0	0	0	0	0	0
5	S533-301-* ①	Control Panel Cover (Outer)	X	X	X	X	X	X
5	S533-309 ②	Control Panel Cover (Outer)	0	0	0	0	0	0
5	S533-310 ③	Control Panel Cover (Outer)	0	0	0	0	0	0
6	S165-608-* ①	Rain Channel	X	X	X	X	X	X
6	S165-609 ②	Rain Channel	0	0	0	0	0	0
6	S165-610 ③	Rain Channel	0	0	0	0	0	0
7	S515-323-* ①	Upper Front	X	X	X	X	X	X
7	S515-328 ②	Upper Front	0	0	0	0	0	0
7	S515-330 ③	Upper Front	0	0	0	0	0	0
8	153-717-* ①	Disconnect Access Door	X	X	X	X	X	X
8	153-723 ②	Disconnect Access Door	0	0	0	0	0	0
8	153-724 ③	Disconnect Access Door	0	0	0	0	0	0
9	S501-1133-* ①	Right Side	X	X	X	X	X	X
9	S501-1134 ②	Right Side	0	0	0	0	0	0
9	S501-1129 ③	Right Side	0	0	0	0	0	0
10	501-1083-* ①	Left Side	X	X	X	X	X	X
10	501-1085 ②	Left Side	0	0	0	0	0	0
10	501-1077 ③	Left Side	0	0	0	0	0	0
11	105X1454	Right Support Angle	X	X	X	X	X	X
12	105Y1454	Left Support Angle	X	X	X	X	X	X
13	105-1457	Coil Support	2	2	2	2	2	2
14	147-055	Coil Support Offset	X	X	X	X	X	X
15	119-126-* ①	Side Grille	2	2	2	2	2	2
15	119-132 ②	Side Grille	2	2	2	2	2	2
15	119-136 ③	Side Grille	2	2	2	2	2	2
16	105-1450	Right Control Panel Angle	X	X	X	X	X	X
17	105-1451	Left Control Panel Angle	X	X	X	X	X	X
18	S543-221-* ①	Heater Access Cover	X	X	X	X	X	X
18	S543-228 ②	Heater Access Cover	0	0	0	0	0	0
18	S543-229 ③	Heater Access Cover	0	0	0	0	0	0
19	507-382-* ①	Top	X	X	X	X	X	X
19	507-391 ②	Top	0	0	0	0	0	0
19	507-392 ③	Top	0	0	0	0	0	0
20	109-412	Lower Back	X	X	X	X	X	X
20	109-418 ②	Lower Back	0	0	0	0	0	0
20	109-422 ③	Lower Back	0	0	0	0	0	0
21	S509-411	Upper Back	X	X	X	X	X	X
21	S509-417 ②	Upper Back	0	0	0	0	0	0
21	S509-421 ③	Upper Back	0	0	0	0	0	0
22	S111-299	Outlet Air Frame Assembly	X	X	X	X	X	X
23	535-129	Heat Shield	X	X	X	X	X	X
24	113-150-* ①	Top Rain Flashing	X	X	X	X	X	X
24	113-150-4 ②	Top Rain Flashing	0	0	0	0	0	0
24	113-359 ③	Top Rain Flashing	0	0	0	0	0	0
25	539-406	Fresh Air Damper Assembly	X	X	X	X	X	X
25	543-222	Intake Blank Off Plate	0	0	0	0	0	0
26	543-220	Exhaust Blank Off Plate	X	X	X	X	X	X
27	S543-248-* ①	Access Cover	X	X	X	X	X	X
27	S543-250 ②	Access Cover	0	0	0	0	0	0
27	S543-251 ③	Access Cover	0	0	0	0	0	0
NS	5252-033	Bard Nameplate	X	X	X	X	X	X

① Exterior cabinet parts are manufactured with various paint color options. To ensure the proper paint color is received, include the complete model and serial number of the unit for which cabinet parts are being ordered.

X – Standard Component
0 – Optional Component

② Exterior cabinet parts are manufactured from aluminum Code "A" (#24 - Top rain flashing not available in aluminum; order 113-150-4 (Buckeye Gray)).
③ Exterior cabinet parts are manufactured from stainless steel Code "S"

EXTERNAL PARTS – STANDARD & DEHUMIDIFICATION

Dwg No.	Part Number	Description	W60ACPA, B, C, E, F, Q	W60ACMA, B, C	W60ACEA, B, C	W72ACPA, B, C, F, Q	W72ACMA, B, C	W72ACEA, B, C
1	S127-574	Unit Base	X	X	X	X	X	X
1	S127-584 ③	Unit Base	0	0	0	0	0	0
2	113-762	Front Base Bracket	X	X	X	X	X	X
2	113-797 ③	Front Base Bracket	0	0	0	0	0	0
3	113-140	Bottom Mounting Bracket	X	X	X	X	X	X
4	119-127-* ①	Front Grille	X	X	X	X	X	X
4	119-133 ②	Front Grille	0	0	0	0	0	0
4	119-137 ③	Front Grille	0	0	0	0	0	0
5	S533-301-* ①	Control Panel Cover (Outer)	X	X	X	X	X	X
5	S533-309 ②	Control Panel Cover (Outer)	0	0	0	0	0	0
5	S533-310 ③	Control Panel Cover (Outer)	0	0	0	0	0	0
6	S165-608-* ①	Rain Channel	X	X	X	X	X	X
6	S165-609 ②	Rain Channel	0	0	0	0	0	0
6	S165-610 ③	Rain Channel	0	0	0	0	0	0
7	S515-324-* ①	Upper Front	X	X	X	X	X	X
7	S515-329 ②	Upper Front	0	0	0	0	0	0
7	S515-331 ③	Upper Front	0	0	0	0	0	0
8	153-717-* ①	Disconnect Access Door	X	X	X	X	X	X
8	153-723 ②	Disconnect Access Door	0	0	0	0	0	0
8	153-724 ③	Disconnect Access Door	0	0	0	0	0	0
9	S501-1135-* ①	Right Side	X	X	X	X	X	X
9	S501-1136 ②	Right Side	0	0	0	0	0	0
9	S501-1132 ③	Right Side	0	0	0	0	0	0
10	501-1081-* ①	Left Side	X	X	X	X	X	X
10	501-1087 ②	Left Side	0	0	0	0	0	0
10	501-1079 ③	Left Side	0	0	0	0	0	0
11	105X1454	Right Support Angle	X	X	X	X	X	X
12	105Y1454	Left Support Angle	X	X	X	X	X	X
13	105-1455	Coil Support	2	2	2	2	2	2
14	147-054	Coil Support Offset	X	X	X	X	X	X
15	119-128-* ①	Side Grille	2	2	2	2	2	2
15	119-134 ②	Side Grille	2	2	2	2	2	2
15	119-138 ③	Side Grille	2	2	2	2	2	2
16	105-1450	Right Control Panel Angle	X	X	X	X	X	X
17	105-1451	Left Control Panel Angle	X	X	X	X	X	X
18	S543-221-* ①	Heater Access Cover	X	X	X	X	X	X
18	S543-228 ②	Heater Access Cover	0	0	0	0	0	0
18	S543-229 ③	Heater Access Cover	0	0	0	0	0	0
19	507-382-* ①	Top	X	X	X	X	X	X
19	507-391 ②	Top	0	0	0	0	0	0
19	507-392 ③	Top	0	0	0	0	0	0
20	109-414	Lower Back	X	X	X	X	X	X
20	109-420 ②	Lower Back	0	0	0	0	0	0
20	109-424 ③	Lower Back	0	0	0	0	0	0
21	S509-413	Upper Back	X	X	X	X	X	X
21	S509-419 ②	Upper Back	0	0	0	0	0	0
21	S509-423 ③	Upper Back	0	0	0	0	0	0
22	S111-299	Outlet Air Frame Assembly	X	X	X	X	X	X
23	535-129	Heat Shield	X	X	X	X	X	X
24	113-150-* ①	Top Rain Flashing	X	X	X	X	X	X
24	113-150-4 ②	Top Rain Flashing	0	0	0	0	0	0
24	113-359 ③	Top Rain Flashing	0	0	0	0	0	0
25	539-406	Fresh Air Damper Assembly	X	X	X	X	X	X
25	543-222	Intake Blank Off Plate	0	0	0	0	0	0
26	543-220	Exhaust Blank Off Plate	X	X	X	X	X	X
27	S543-248-* ①	Access Cover	X	X	X	X	X	X
27	S543-250 ②	Access Cover	0	0	0	0	0	0
27	S543-251 ③	Access Cover	0	0	0	0	0	0
NS	5252-033	Bard Nameplate	X	X	X	X	X	X

① Exterior cabinet parts are manufactured with various paint color options. To ensure the proper paint color is received, include the complete model and serial number of the unit for which cabinet parts are being ordered.

X – Standard Component
0 – Optional Component

Refer to drawing on page 2

This page intentionally left blank

INTERNAL PARTS

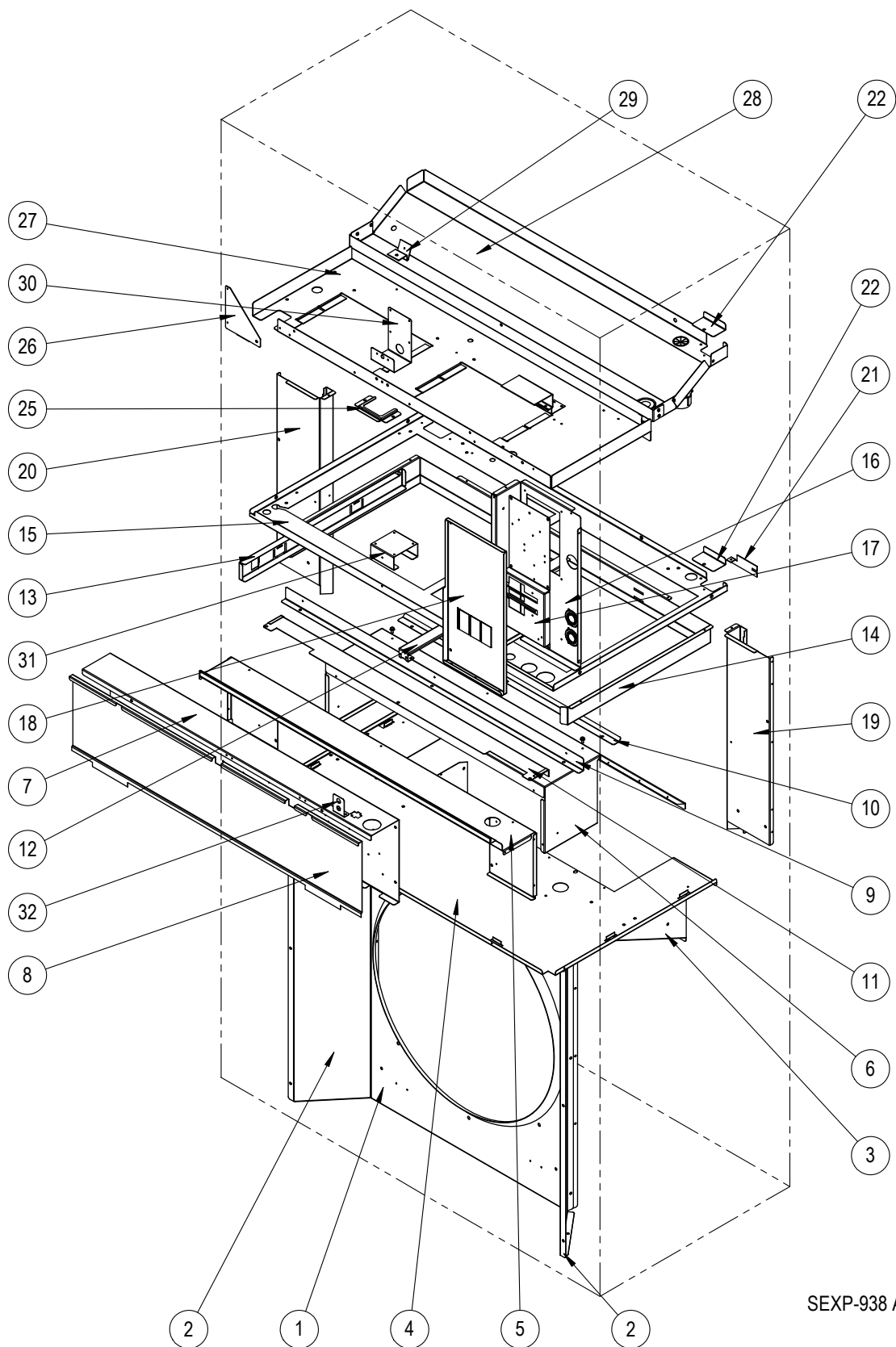

SEXP-938 A

INTERNAL PARTS – STANDARD & DEHUMIDIFICATION

Dwg No.	Part Number	Description	W42ACPA, B, E	W42ACPC, F	W42ACMA, B	W42ACMC	W42ACEA, B	W42ACEC	W48ACPA, B, E	W48ACPC, F, Q	W48ACMA, B	W48ACMC	W48ACEA, B	W48ACEC
1	125-089	Fan Shroud	X	X	X	X	X	X	X	X	X	X	X	X
1	125-093 ①	Fan Shroud	0	0	0	0	0	0	0	0	0	0	0	0
2	S125-090	Fan Shroud Side Access Cover	2	2	2	2	2	2	2	2	2	2	2	2
2	S125-094 ①	Fan Shroud Side Access Cover	2	2	2	2	2	2	2	2	2	2	2	2
3	121-586	Condenser Partition Insert	X	X	X	X	X	X	X	X	X	X	X	X
3	121-600 ①	Condenser Partition Insert	0	0	0	0	0	0	0	0	0	0	0	0
4	121-585	Condenser Partition	X	X	X	X	X	X	X	X	X	X	X	X
4	121-599 ①	Condenser Partition	0	0	0	0	0	0	0	0	0	0	0	0
5	521-630	Front Exhaust Partition	X	X	X	X	X	X	X	X	X	X	X	X
6	521-587	Exhaust Partition	X	X	X	X	X	X	X	X	X	X	X	X
7	Control Panel Assy.	See Control Panel Assy. Drawing & Parts List	X	X	X	X	X	X	X	X	X	X	X	X
8	S133-330	Control Panel Cover (Inner)	X	X	X	X	X	X	X	X	X	X	X	X
9	105-1453	Front Vent Guide Rail	X	X	X	X	X	X	X	X	X	X	X	X
10	105-1452	Vent Guide Rail	X	X	X	X	X	X	X	X	X	X	X	X
11	S135-409	Field Wire Shield	X	X	X	X	X	X	X	X	X	X	X	X
12	131-168	Filter Support Bracket	2	2	2	2	2	2	2	2	2	2	2	2
13	131-170	Filter Slide	X	X	X	X	X	X	X	X	X	X	X	X
14	131-169	Filter Rack Frame	X	X	X	X	X	X	X	X	X	X	X	X
15	121-583	Filter Partition	X	X	X	X	X	X	X	X	X	X	X	X
16	117-412	Upper Control Panel	X	X	X	X	X	X	X	X	X	X	X	X
17	127-575	Circuit Breaker Base	X		X		X		X		X		X	
17	127-585	Circuit Breaker Base - 460V		X		X		X		X		X		X
18	S133-303	Upper Control Panel Cover	X		X		X		X		X		X	
18	S133-304	Upper Control Panel Cover - 460V		X		X		X		X		X		X
19	135X393	Right Copper Chase	X	X	X	X	X	X	X	X	X	X	X	X
19	135X397 ①	Right Copper Chase	0	0	0	0	0	0	0	0	0	0	0	0
20	135Y393	Left Copper Chase	X	X	X	X	X	X	X	X	X	X	X	X
20	135Y397 ①	Left Copper Chase	0	0	0	0	0	0	0	0	0	0	0	0
21	113-796	Copper Retainer	2	2	2	2	2	2	2	2	2	2	2	2
22	137-920	Copper Fill Plate	2	2	2	2	2	2	2	2	2	2	2	2
25	113-765	Grommet Retainer	X	X	X	X	X	X	X	X	X	X	X	X
26	141-492	Blower Partition Support	X	X	X	X	X	X	X	X	X	X	X	X
27	121-582	Blower Partition	X	X	X	X	X	X	X	X	X	X	X	X
28	523-161	Drain Pan	X	X	X	X	X	X	X	X	X	X	X	X
28	523-162 ①②	Drain Pan	0	0	0	0	0	0	0	0	0	0	0	0
29	113-768	EEV mounting Bracket			X	X	X	X			X	X	X	X
30	113-787	Airflow Switch Bracket	0	0	0	0	0	0	0	0	0	0	0	0
31	113-788	Filter Switch Bracket	0	0	0	0	0	0	0	0	0	0	0	0
32	113-789	Filter Switch Light Bracket	0	0	0	0	0	0	0	0	0	0	0	0

① Exterior cabinet parts are manufactured from stainless steel Code "S"

② For aluminum units, order 523-162 stainless steel drain pan.

X – Standard Component

0 – Optional Component

INTERNAL PARTS – STANDARD & DEHUMIDIFICATION

Dwg No.	Part Number	Description	W60ACPA, B, E	W60ACPC, F, Q	W60ACMA, B	W60ACMC	W60ACEA, B	W60ACEC	W72ACPA, B	W72ACPC, F, Q	W72ACMA, B	W72ACMC	W72ACEA, B	W72ACEC
1	125-091	Fan Shroud	X	X	X	X	X	X	X	X	X	X	X	X
1	125-095 ①	Fan Shroud	0	0	0	0	0	0	0	0	0	0	0	0
2	S125-092	Fan Shroud Side Access Cover	2	2	2	2	2	2	2	2	2	2	2	2
2	S125-096 ①	Fan Shroud Side Access Cover	2	2	2	2	2	2	2	2	2	2	2	2
3	121-586	Condenser Partition Insert	X	X	X	X	X	X	X	X	X	X	X	X
3	121-600 ①	Condenser Partition Insert	0	0	0	0	0	0	0	0	0	0	0	0
4	121-585	Condenser Partition	X	X	X	X	X	X	X	X	X	X	X	X
4	121-599 ①	Condenser Partition	0	0	0	0	0	0	0	0	0	0	0	0
5	521-630	Front Exhaust Partition	X	X	X	X	X	X	X	X	X	X	X	X
6	521-587	Exhaust Partition	X	X	X	X	X	X	X	X	X	X	X	X
7	Control Panel Assy.	See Control Panel Assy. Drawing & Parts List	X	X	X	X	X	X	X	X	X	X	X	X
8	S133-330	Control Panel Cover (Inner)	X	X	X	X	X	X	X	X	X	X	X	X
9	105-1453	Front Vent Guide Rail	X	X	X	X	X	X	X	X	X	X	X	X
10	105-1452	Vent Guide Rail	X	X	X	X	X	X	X	X	X	X	X	X
11	S135-409	Field Wire Shield	X	X	X	X	X	X	X	X	X	X	X	X
12	131-168	Filter Support Bracket	2	2	2	2	2	2	2	2	2	2	2	2
13	131-170	Filter Slide	X	X	X	X	X	X	X	X	X	X	X	X
14	131-169	Filter Rack Frame	X	X	X	X	X	X	X	X	X	X	X	X
15	121-583	Filter Partition	X	X	X	X	X	X	X	X	X	X	X	X
16	117-412	Upper Control Panel	X	X	X	X	X	X	X	X	X	X	X	X
17	127-575	Circuit Breaker Base	X		X		X		X		X		X	
17	127-585	Circuit Breaker Base - 460V		X		X		X		X		X		X
18	S133-303	Upper Control Panel Cover	X		X		X		X		X		X	
18	S133-304	Upper Control Panel Cover - 460V		X		X		X		X		X		X
19	135X393	Right Copper Chase	X	X	X	X	X	X	X	X	X	X	X	X
19	135X397 ①	Right Copper Chase	0	0	0	0	0	0	0	0	0	0	0	0
20	135Y393	Left Copper Chase	X	X	X	X	X	X	X	X	X	X	X	X
20	135Y397 ①	Left Copper Chase	0	0	0	0	0	0	0	0	0	0	0	0
21	113-796	Copper Retainer	2	2	2	2	2	2	2	2	2	2	2	2
22	137-920	Copper Fill Plate	2	2	2	2	2	2	2	2	2	2	2	2
25	113-765	Grommet Retainer	X	X	X	X	X	X	X	X	X	X	X	X
26	141-492	Blower Partition Support	X	X	X	X	X	X	X	X	X	X	X	X
27	121-582	Blower Partition	X	X	X	X	X	X	X	X	X	X	X	X
28	523-161	Drain Pan	X	X	X	X	X	X	X	X	X	X	X	X
28	523-162 ①②	Drain Pan	0	0	0	0	0	0	0	0	0	0	0	0
29	113-768	EEV mounting Bracket			X	X	X	X			X	X	X	X
30	113-787	Airflow Switch Bracket	0	0	0	0	0	0	0	0	0	0	0	0
31	113-788	Filter Switch Bracket	0	0	0	0	0	0	0	0	0	0	0	0
32	113-789	Filter Switch Light Bracket	0	0	0	0	0	0	0	0	0	0	0	0

① Exterior cabinet parts are manufactured from stainless steel Code "S"

② For aluminum units, order 523-162 stainless steel drain pan.

X – Standard Component

0 – Optional Component

Refer to drawing on page 6

This page intentionally left blank

FUNCTIONAL COMPONENTS

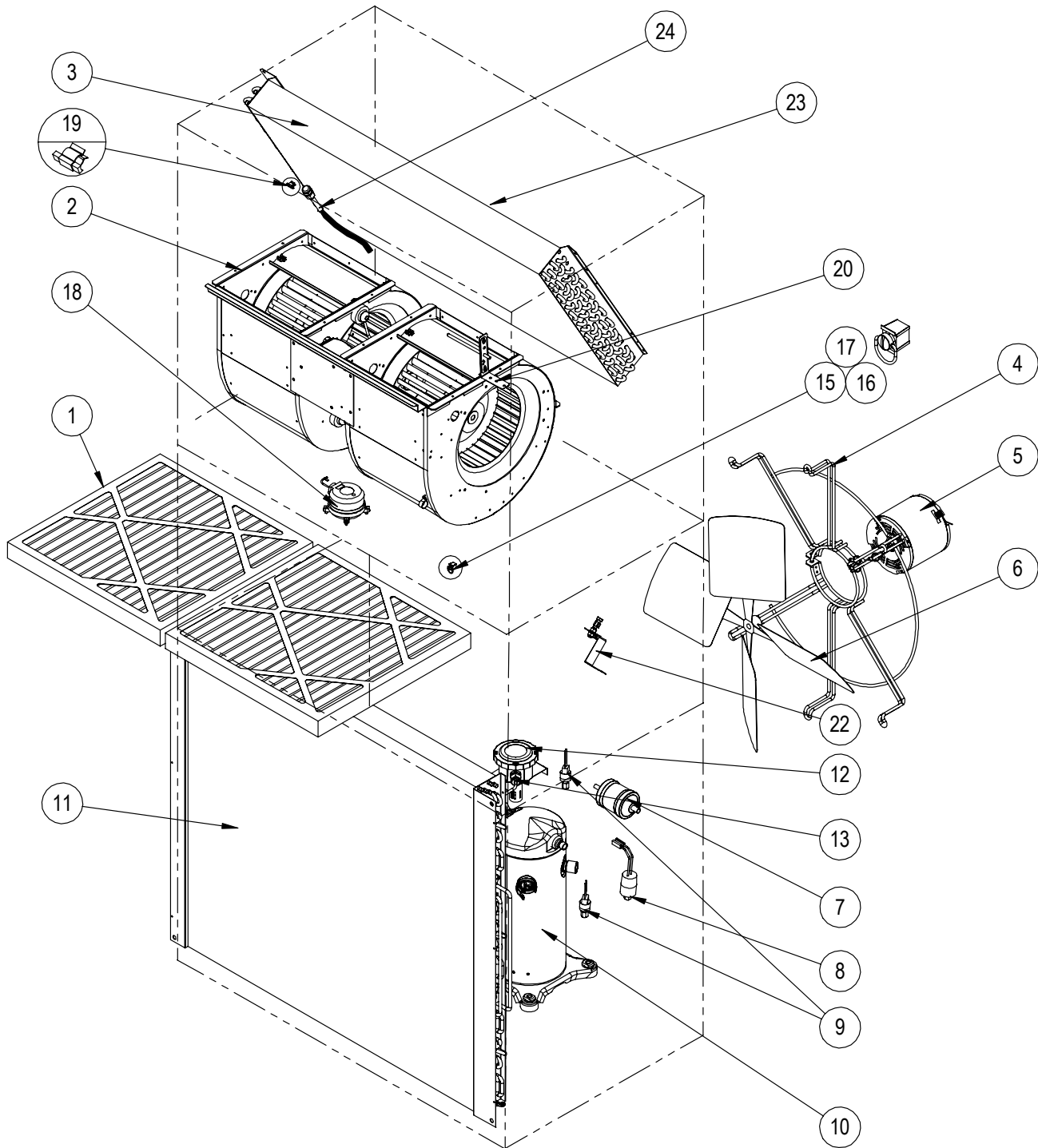

SEXP-1012B

This drawing to be used for reference for pages 11, 12, 13 and 14

FUNCTIONAL COMPONENTS

Dwg No.	Part Number	Description	W42ACPA	W42ACPB	W42ACPC	W42ACPE	W42ACPF	W42ACMA	W42ACMB	W42ACMC	W42ACEA	W42ACEB	W42ACEC
1	7004-012	Air Filter 1" Throw-Away (20 x 20 x 1)	2	2	2	2	2	2	2	2	2	2	2
1	7003-085 ①	Air Filter 1" Washable (20 x 20 x 1)	2	2	2	2	2	2	2	2	2	2	2
1	7004-052 ①	Air Filter 2" Merv 8 (20 x 20 x 2)	2	2	2	2	2	2	2	2	2	2	2
1	7004-060 ①	Air Filter 2" Merv 11 (20 x 20 x 2)	2	2	2	2	2	2	2	2	2	2	2
1	7004-063 ①	Air Filter 2" Merv 13 (20 x 20 x 2)	2	2	2	2	2	2	2	2	2	2	2
2	900-366-0155BX	Blower Assembly	X	X		X	X	X	X		X	X	
2	900-367-0156BX	Blower Assembly - 460V			X					X			X
3	917-0366BX	Evaporator Coil w/Distributor Assy.	X	X	X	X	X	X	X	X	X	X	X
3	917-0367BX	Evaporator Coil - Coated w/Distributor Assy.	0	0	0	0	0	0	0	0	0	0	0
4	8200-004	Fan Motor Mount	X	X	X	X	X	X	X	X	X	X	X
4	8200-051 ②	Fan Motor Mount	0	0	0	0	0	0	0	0	0	0	0
5	8105-039	Condenser Motor 1/3HP 230/208 CW PSC 825RPM				X	X						
5	8105-068	Condenser Motor 1/3HP 230/208 CW PSC 825RPM	X	X				X	X		X	X	
5	8105-071	Condenser Motor 1/3HP 460V CW PSC			X					X			X
6	5151-060	Fan Blade	X	X	X	X	X	X	X	X	X	X	X
6	5151C060 ②	Fan Blade - Coated	0	0	0	0	0	0	0	0	0	0	0
7	5201-022	Filter Drier	X	X	X	X	X	X	X	X	X	X	X
8	8406-112	Low Ambient Control 350#/225#	X	X	X	X	X	X	X	X	X	X	X
9	8406-142	High Pressure Switch	X	X	X	X	X	X	X	X	X	X	X
9	910-2135	Low Pressure Switch Assy.	X	X	X	X	X	X	X	X	X	X	X
10	8000-349	Compressor	X					X			X		
10	8000-350	Compressor		X		X			X			X	
10	8000-351	Compressor			X		X			X			X
11	5051-222BX	Condenser Coil	X	X	X	X	X	X	X	X	X	X	X
11	5054-222BX	Condenser Coil - Coated	0	0	0	0	0	0	0	0	0	0	0
12	910-2109	Outdoor Temperature and Humidity Sensor Assy.	X	X	X	X	X	X	X	X	X	X	X
13	8406-158	Low Pressure Transducer						X	X	X			
15	1171-023	1/4 Turn Receptacle	X	X	X	X	X	X	X	X	X	X	X
16	1171-022	1/4 Turn Fastener	X	X	X	X	X	X	X	X	X	X	X
17	1171-024	1/4 Turn Retainer	X	X	X	X	X	X	X	X	X	X	X
18	910-2101	Filter Pressure Switch Assy.	X	X	X	X	X	X	X	X	X	X	X
19	910-2113	Freeze Protection Thermostat Assy.	X	X	X	X	X	X	X	X	X	X	X
20	910-2106	Mixed Air Sensor Assy.	X	X	X	X	X	X	X	X	X	X	X
22	910-2099	Return Air Sensor Assy.	X	X	X	X	X	X	X	X	X	X	X
23	5051-221BX	Reheat Coil						X	X	X			
23	5054-221BX	Reheat Coil - Coated						0	0	0			
24	800-0482	Distributor Assembly	X	X	X	X	X				X	X	X
24	800-0424	Distributor Assembly						X	X	X			
24	5651S245	Electronic Expansion Valve						X	X	X			
24	905-0737	Electronic Expansion Valve (EEV) Assy.						X	X	X			
NS	5451-024	Tubing Isolation Grommet	2	2	2	2	2	2	2	2	2	2	2
NS	6031-009	Coremax Valve Core	2	2	2	2	2	2	2	2	2	2	2
NS	1171-070	Control Panel Door Clip	4	4	4	4	4	4	4	4	4	4	4
NS	1171-068	Control Panel Door Screw	4	4	4	4	4	4	4	4	4	4	4
NS	1171-069	Control Panel Door Screw Retainer	4	4	4	4	4	4	4	4	4	4	4
NS	3000-1696	Transducer Wire Assy.						X	X	X			
NS	5651-246	EEV Stator Cable						X	X	X			
NS	910-2134	Suction Temp Sensor Assy.						X	X	X			

NS – Not Shown

① – Optional on these models

② – Used with stainless steel cabinet option

X – Standard Component

0 – Optional Component

FUNCTIONAL COMPONENTS

Dwg No.	Part Number	Description	W48ACPA	W48ACPB	W48ACPC	W48ACPE	W48ACPF	W48ACPG	W48ACMA	W48ACMB	W48ACMC	W48ACEA	W48ACEB	W48ACEC
1	7004-012	Air Filter 1" Throw-Away (20 x 20 x 1)	2	2	2	2	2	2	2	2	2	2	2	2
1	7003-085 ①	Air Filter 1" Washable (20 x 20 x 1)	2	2	2	2	2	2	2	2	2	2	2	2
1	7004-052 ①	Air Filter 2" Merv 8 (20 x 20 x 2)	2	2	2	2	2	2	2	2	2	2	2	2
1	7004-060 ①	Air Filter 2" Merv 11 (20 x 20 x 2)	2	2	2	2	2	2	2	2	2	2	2	2
1	7004-063 ①	Air Filter 2" Merv 13 (20 x 20 x 2)	2	2	2	2	2	2	2	2	2	2	2	2
2	900-368-0157BX	Blower Assembly	X	X		X	X	X	X	X		X	X	
2	900-369-0158BX	Blower Assembly - 460V			X						X			X
3	917-0370BX	Evaporator Coil w/Distributor Assy.	X	X	X	X	X	X	X	X	X	X	X	X
3	917-0371BX	Evaporator Coil - Coated w/Distributor Assy.	0	0	0	0	0	0	0	0	0	0	0	0
4	8200-004	Fan Motor Mount	X	X	X	X	X	X	X	X	X	X	X	X
4	8200-051 ②	Fan Motor Mount	0	0	0	0	0	0	0	0	0	0	0	0
5	8105-039	Condenser Motor 1/3HP 230/208 CW PSC 825RPM				X	X							
5	8105-068	Condenser Motor 1/3HP 230/208 CW PSC 825RPM	X	X				X	X	X		X	X	
5	8105-071	Condenser Motor 1/3HP 460V CW PSC			X						X			X
6	5151-060	Fan Blade	X	X	X	X	X	X	X	X	X	X	X	X
6	5151C060 ②	Fan Blade - Coated	0	0	0	0	0	0	0	0	0	0	0	0
7	5201-022	Filter Drier	X	X	X	X	X	X	X	X	X	X	X	X
8	8406-112	Low Ambient Control 350#/225#	X	X	X	X	X	X	X	X	X	X	X	X
9	8406-142	High Pressure Switch	X	X	X	X	X	X	X	X	X	X	X	X
9	910-2135	Low Pressure Switch Assy.	X	X	X	X	X	X	X	X	X	X	X	X
10	8000-332	Compressor	X						X			X		
10	8000-333	Compressor		X		X				X			X	
10	8000-334	Compressor			X		X				X			X
10	8000-466	Compressor					X							
11	5051-222BX	Condenser Coil	X	X	X	X	X	X	X	X	X	X	X	X
11	5054-222BX	Condenser Coil - Coated	0	0	0	0	0	0	0	0	0	0	0	0
12	910-2109	Outdoor Temperature and Humidity Sensor Assy.	X	X	X	X	X	X	X	X	X	X	X	X
13	8406-158	Low Pressure Transducer							X	X	X			
15	1171-023	1/4 Turn Receptacle	X	X	X	X	X	X	X	X	X	X	X	X
16	1171-022	1/4 Turn Fastener	X	X	X	X	X	X	X	X	X	X	X	X
17	1171-024	1/4 Turn Retainer	X	X	X	X	X	X	X	X	X	X	X	X
18	910-2101	Filter Pressure Switch Assy.	X	X	X	X	X	X	X	X	X	X	X	X
19	910-2113	Freeze Protection Thermostat Assy.	X	X	X	X	X	X	X	X	X	X	X	X
20	910-2106	Mixed Air Sensor Assy.	X	X	X	X	X	X	X	X	X	X	X	X
22	910-2099	Return Air Sensor Assy.	X	X	X	X	X	X	X	X	X	X	X	X
23	5051-221BX	Reheat Coil							X	X	X			
23	5054-221BX	Reheat Coil - Coated							0	0	0			
24	800-0483	Distributor Assembly	X	X	X	X	X	X				X	X	X
24	800-0455	Distributor Assembly							X	X	X			
24	5651S245	Electronic Expansion Valve							X	X	X			
24	905-0737	Electronic Expansion Valve (EEV) Assy.							X	X	X			
NS	5451-024	Tubing Isolation Grommet	2	2	2	2	2	2	2	2	2	2	2	2
NS	6031-009	Coremax Valve Core	2	2	2	2	2	2	2	2	2	2	2	2
NS	1171-070	Control Panel Door Clip	4	4	4	4	4	4	4	4	4	4	4	4
NS	1171-068	Control Panel Door Screw	4	4	4	4	4	4	4	4	4	4	4	4
NS	1171-069	Control Panel Door Screw Retainer	4	4	4	4	4	4	4	4	4	4	4	4
NS	910-1963	575/230V Transformer Assy.						X						
NS	3000-1696	Transducer Wire Assy.							X	X	X			
NS	5651-246	EEV Stator Cable							X	X	X			
NS	910-2134	Suction Temp Sensor Assy.							X	X	X			

NS – Not Shown

① – Optional on these models

② – Used with stainless steel cabinet option

X – Standard Component

0 – Optional Component

FUNCTIONAL COMPONENTS

Dwg No.	Part Number	Description	W60ACPA	W60ACPB	W60ACPC	W60ACPE	W60ACPF	W60ACPG	W60ACMA	W60ACMB	W60ACMC	W60ACEA	W60ACEB	W60ACEC
1	7004-012	Air Filter 1" Throw-Away (20 x 20 x 1)	2	2	2	2	2	2	2	2	2	2	2	2
1	7003-085 ①	Air Filter 1" Washable (20 x 20 x 1)	2	2	2	2	2	2	2	2	2	2	2	2
1	7004-052 ①	Air Filter 2" Merv 8 (20 x 20 x 2)	2	2	2	2	2	2	2	2	2	2	2	2
1	7004-060 ①	Air Filter 2" Merv 11 (20 x 20 x 2)	2	2	2	2	2	2	2	2	2	2	2	2
1	7004-063 ①	Air Filter 2" Merv 13 (20 x 20 x 2)	2	2	2	2	2	2	2	2	2	2	2	2
2	900-368-0159BX	Blower Assembly	X	X		X	X	X	X	X		X	X	
2	900-369-0160BX	Blower Assembly - 460V			X						X			X
3	917-0374BX	Evaporator Coil w/Distributor Assy.	X	X	X	X	X	X	X	X	X	X	X	X
3	917-0375BX	Evaporator Coil - Coated w/Distributor Assy.	O	O	O	O	O	O	O	O	O	O	O	O
4	8200-004	Fan Motor Mount	X	X	X	X	X	X	X	X	X	X	X	X
4	8200-051 ②	Fan Motor Mount	O	O	O	O	O	O	O	O	O	O	O	O
5	8105-039	Condenser Motor 1/3HP 230/208 CW PSC 825RPM				X	X							
5	8106-053	Condenser Motor 1/3HP 460V CW PSC 1075RPM						X						
5	8105-068	Condenser Motor 1/3HP 230/208 CW PSC 825RPM	X	X					X	X		X	X	
5	8105-071	Condenser Motor 1/3HP 460V CW PSC			X						X			X
6	5151-060	Fan Blade	X	X	X	X	X	X	X	X	X	X	X	X
6	5151C060 ②	Fan Blade - Coated	O	O	O	O	O	O	O	O	O	O	O	O
7	5201-022	Filter Drier	X	X	X	X	X	X	X	X	X	X	X	X
8	8406-112	Low Ambient Control 350#/225#	X	X	X	X	X	X	X	X	X	X	X	X
9	8406-142	High Pressure Switch	X	X	X	X	X	X	X	X	X	X	X	X
9	910-2135	Low Pressure Switch Assy.	X	X	X	X	X	X	X	X	X	X	X	X
10	8000-289	Compressor	X						X			X		
10	8000-292	Compressor		X		X				X			X	
10	8000-308	Compressor			X		X				X			X
10	8000-467	Compressor					X							
11	5051-223BX	Condenser Coil	X	X	X	X	X	X	X	X	X	X	X	X
11	5054-223BX	Condenser Coil - Coated	O	O	O	O	O	O	O	O	O	O	O	O
12	8301-067	Outdoor Temperature and Humidity Sensor	X	X	X	X	X	X	X	X	X	X	X	X
13	8406-158	Low Pressure Transducer							X	X	X			
15	1171-023	1/4 Turn Receptacle	X	X	X	X	X	X	X	X	X	X	X	X
16	1171-022	1/4 Turn Fastener	X	X	X	X	X	X	X	X	X	X	X	X
17	1171-024	1/4 Turn Retainer	X	X	X	X	X	X	X	X	X	X	X	X
18	8301-057	Filter Pressure Switch	X	X	X	X	X	X	X	X	X	X	X	X
19	910-2113	Freeze Protection Thermostat Assy.	X	X	X	X	X	X	X	X	X	X	X	X
20	910-2106	Mixed Air Sensor	X	X	X	X	X	X	X	X	X	X	X	X
22	910-2099	Return Air Sensor Assembly	X	X	X	X	X	X	X	X	X	X	X	X
23	5051-221BX	Reheat Coil							X	X	X			
23	5054-221BX	Reheat Coil - Coated							O	O	O			
24	800-0484	Distributor Assembly	X	X	X	X	X	X				X	X	X
24	800-0455	Distributor Assembly							X	X	X			
24	5651S248	Electronic Expansion Valve							X	X	X			
24	905-0745	Electronic Expansion Valve (EEV) Assy.							X	X	X			
NS	5451-024	Tubing Isolation Grommet	2	2	2	2	2	2	2	2	2	2	2	2
NS	6031-009	Coremax Valve Core	2	2	2	2	2	2	2	2	2	2	2	2
NS	1171-070	Control Panel Door Clip	4	4	4	4	4	4	4	4	4	4	4	4
NS	1171-058	Control Panel Door Screw	4	4	4	4	4	4	4	4	4	4	4	4
NS	1171-069	Control Panel Door Screw Retainer	4	4	4	4	4	4	4	4	4	4	4	4
NS	910-1963	575/230V Transformer Assy.						X						
NS	8605-017	Crankcase Heater - 230V	X	X		X	X		X	X		X	X	
NS	8605-018	Crankcase Heater - 460V			X						X			X
NS	8605-021	Crankcase Heater - 575V						X						
NS	3000-1696	Transducer Wire Assy.							X	X	X			
NS	5651-246	EEV Stator Cable							X	X	X			
NS	910-2134	Suction Temp Sensor Assy.							X	X	X			

NS – Not Shown
 ① – Optional on these models
 ② – Used with stainless steel cabinet option

X – Standard Component
 O – Optional Component

Refer to drawing on page 10

FUNCTIONAL COMPONENTS

Dwg No.	Part Number	Description	W72ACPA	W72ACPB	W72ACPC	W72ACPF	W72ACPQ	W72ACMA	W72ACMB	W72ACMC	W72ACEA	W72ACEB	W72ACEC
1	7004-012	Air Filter 1" Throw-Away (20 x 20 x 1)	2	2	2	2	2	2	2	2	2	2	2
1	7003-085 ①	Air Filter 1" Washable (20 x 20 x 1)	2	2	2	2	2	2	2	2	2	2	2
1	7004-052 ①	Air Filter 2" Merv 8 (20 x 20 x 2)	2	2	2	2	2	2	2	2	2	2	2
1	7004-060 ①	Air Filter 2" Merv 11 (20 x 20 x 2)	2	2	2	2	2	2	2	2	2	2	2
1	7004-063 ①	Air Filter 2" Merv 13 (20 x 20 x 2)	2	2	2	2	2	2	2	2	2	2	2
2	900-368-0161BX	Blower Assembly	X	X		X	X	X	X		X	X	
2	900-369-0162BX	Blower Assembly - 460V			X					X			X
3	917-0378BX	Evaporator Coil w/Distributor Assy.	X	X	X	X	X	X	X	X	X	X	X
3	917-0379BX	Evaporator Coil - Coated w/Distributor Assy.	0	0	0	0	0	0	0	0	0	0	0
4	8200-049	Fan Motor Mount	X	X	X	X	X	X	X	X	X	X	X
4	8200-052 ②	Fan Motor Mount	0	0	0	0	0	0	0	0	0	0	0
5	8106-070	Condenser Motor	X	X		X		X	X		X	X	
5	8106-071	Condenser Motor - 460V			X					X			X
5	8106-053	Condenser Motor					X						
6	5151-063	Fan Blade	X	X	X	X	X	X	X	X	X	X	X
6	5151C063 ②	Fan Blade - Coated	0	0	0	0	0	0	0	0	0	0	0
7	5201-022	Filter Drier	X	X	X	X	X	X	X	X	X	X	X
8	8406-112	Low Ambient Control 350#/225#	X	X	X	X	X	X	X	X	X	X	X
9	8406-142	High Pressure Switch	X	X	X	X	X	X	X	X	X	X	X
9	910-2135	Low Pressure Switch Assy.	X	X	X	X	X	X	X	X	X	X	X
10	8000-403	Compressor	X					X			X		
10	8000-404	Compressor		X					X			X	
10	8000-405	Compressor			X	X				X			X
10	8000-418	Compressor					X						
11	5051-223BX	Condenser Coil	X	X	X	X	X	X	X	X	X	X	X
11	5054-223BX	Condenser Coil - Coated	0	0	0	0	0	0	0	0	0	0	0
12	8301-067	Outdoor Temperature and Humidity Sensor	X	X	X	X	X	X	X	X	X	X	X
13	8406-158	Low Pressure Transducer						X	X	X			
15	1171-023	1/4 Turn Receptacle	X	X	X	X	X	X	X	X	X	X	X
16	1171-022	1/4 Turn Fastener	X	X	X	X	X	X	X	X	X	X	X
17	1171-024	1/4 Turn Retainer	X	X	X	X	X	X	X	X	X	X	X
18	8301-057	Filter Pressure Switch	X	X	X	X	X	X	X	X	X	X	X
19	910-2113	Freeze Protection Thermostat Assy.	X	X	X	X	X	X	X	X	X	X	X
20	910-2106	Mixed Air Sensor	X	X	X	X	X	X	X	X	X	X	X
22	910-2099	Return Air Sensor Assembly	X	X	X	X	X	X	X	X	X	X	X
23	5051-221BX	Reheat Coil						X	X	X			
23	5054-221BX	Reheat Coil - Coated						0	0	0			
24	800-0454	Distributor Assembly	X	X	X	X	X				X	X	X
24	800-0455	Distributor Assembly						X	X	X			
24	5651S248	Electronic Expansion Valve						X	X	X			
24	905-0745	Electronic Expansion Valve (EEV) Assy.						X	X	X			
NS	5451-024	Tubing Isolation Grommet	2	2	2	2	2	2	2	2	2	2	2
NS	6031-009	Coremax Valve Core	2	2	2	2	2	2	2	2	2	2	2
NS	1171-070	Control Panel Door Clip	4	4	4	4	4	4	4	4	4	4	4
NS	1171-058	Control Panel Door Screw	4	4	4	4	4	4	4	4	4	4	4
NS	1171-069	Control Panel Door Screw Retainer	4	4	4	4	4	4	4	4	4	4	4
NS	910-1963	575/230V Transformer Assy.					X						
NS	8605-017	Crankcase Heater - 230V	X	X		X		X	X		X	X	
NS	8605-018	Crankcase Heater - 460V			X					X			X
NS	8605-021	Crankcase Heater - 575V					X						
NS	3000-1696	Transducer Wire Assy.						X	X	X			
NS	5651-246	EEV Stator Cable						X	X	X			
NS	910-2134	Suction Temp Sensor Assy.						X	X	X			

NS – Not Shown

① – Optional on these models

② – Used with stainless steel cabinet option

X – Standard Component

0 – Optional Component

This page intentionally left blank

CONTROL PANEL

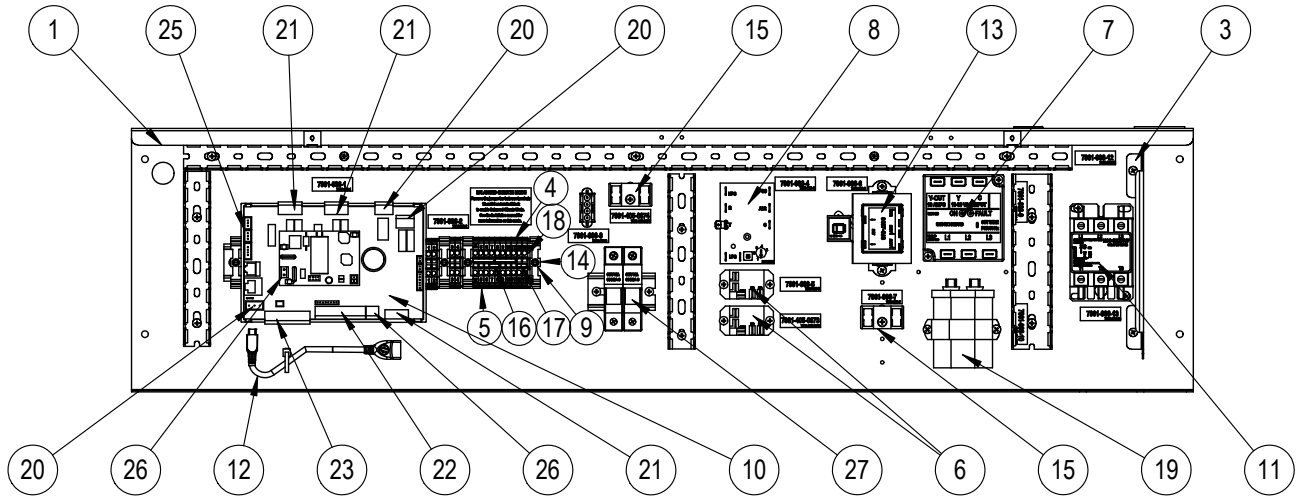

SEXP-1007 C

This drawing to be used for reference for pages 17, 18, 19 and 20

CONTROL PANEL

Dwg No.	Part Number	Description	W42ACPA	W42ACPB	W42ACPC	W42ACPE	W42ACPF	W42ACMA	W42ACMB	W42ACMC	W42ACEA	W42ACEB	W42ACEC
1	117-417	Control Panel Assembly	X	X	X	X	X	X	X	X	X	X	X
3	135-394	Wire Shield	X	X	X	X	X	X	X	X	X	X	X
4	8607-055	Terminal Designation (11-20)	X	X	X	X	X	X	X	X	X	X	X
5	8607-056	Terminal Designation (1-10)	X	X	X	X	X	X	X	X	X	X	X
6	8201-174BX	3 Phase Line Monitor 50/60 HZ		X	X	X	X		X	X		X	X
7	8201-130	Relay, SPDT, Pilot Duty	X	X	X	X	X	X	X	X	X	X	X
8	8201-176BX	Compressor Control Module	X	X	X	X	X	X	X	X	X	X	X
9	8611-150	Terminal Block DIN Rail	X	X	X	X	X	X	X	X	X	X	X
10	8301-096-002*	UPC3-C2 MULTI-TEC	X	X	X	X	X	X	X	X	X	X	X
11	8401-037	Contactor 3 Pole 30 Amp w/Aux. Contact		X	X	X	X		X	X		X	X
11	8401-038	Contactor 2 Pole 40 Amp w/Aux. Contact	X					X			X		
12	8301-075	USB Micro Cable Female to Male	X	X	X	X	X	X	X	X	X	X	X
13	8407-065	Transformer 208/240-24 75VA	X	X		X	X	X			X	X	
13	8407-072	Transformer 460/24VAC 75VA			X					X			X
14	8611-144	End Clamp for DIN Rail	4	4	4	4	4	4	4	4	4	4	4
15	8607-017	Terminal Block 240V 2 Terminal	X	X	X	X	X	X	X	X	X	X	X
16	8611-194	Jumper 2 Position	X	X	X	X	X	X	X	X	X	X	X
17	8611-195	Jumper 4 Position	X	X	X	X	X	X	X	X	X	X	X
18	8611-151	Terminal Block End Cap for DIN Rail	X	X	X	X	X	X	X	X	X	X	X
19	8552-004	Capacitor 7-1/2MFD 370V 1-1/4" O			X		X			X			X
19	8552-005	Capacitor 10MFD 370V1-1/4" O		X		X			X			X	
19	8552-079	Capacitor 45/10 MFD 370V	X					X			X		
20	8611-147	3-Pin Circuit Board Connector	X	X	X	X	X	X	X	X	X	X	X
21	8611-148	4-Pin Circuit Board Connector	X	X	X	X	X	X	X	X	X	X	X
22	8611-149	9-Pin Circuit Board Connector	X	X	X	X	X	X	X	X	X	X	X
23	8611-185	8-Pin Circuit Board Connector	X	X	X	X	X	X	X	X	X	X	X
25	8611-192	3-Pin Circuit Board Connector	X	X	X	X	X	X	X	X	X	X	X
26	8611-183	2-Pin Circuit Board Connector	X	X	X	X	X	X	X	X	X	X	X
NS	4207-109	Wiring Diagram	X								X		
NS	4207-110	Wiring Diagram						X					
NS	4207-209	Wiring Diagram		X		X						X	
NS	4207-210	Wiring Diagram							X				
NS	4207-309	Wiring Diagram			X					X			X
NS	4207-310	Wiring Diagram								X			
NS	4207-610	Wiring Diagram					X						

* Replacement part will have a letter attached to the end of the part number to designate software version (Example: 8301-096-002**A**). A software upgrade of all PLCs onsite (units and controllers) should accompany any PLC replacement. Latest revisions of software, change log and instructions are available on the Bard website at <http://www.bardhvac.com/software-download/>

NS = Not Shown

CONTROL PANEL

Dwg No.	Part Number	Description	W48ACPA	W48ACPB	W48ACPC	W48ACPE	W48ACPF	W48ACPQ	W48ACMA	W48ACMB	W48ACMC	W48ACEA	W48ACEB	W48ACEC
1	117-417	Control Panel Assembly	X	X	X	X	X	X	X	X	X	X	X	X
3	135-394	Wire Shield	X	X	X	X	X	X	X	X	X	X	X	X
4	8607-055	Terminal Designation (11-20)	X	X	X	X	X	X	X	X	X	X	X	X
5	8607-056	Terminal Designation (1-10)	X	X	X	X	X	X	X	X	X	X	X	X
6	8201-174BX	3 Phase Line Monitor 50/60 HZ		X	X	X	X	X		X	X		X	X
7	8201-130	Relay, SPDT, Pilot Duty	X	X	X	X	X	2	X	X	X	X	X	X
8	8201-176BX	Compressor Control Module	X	X	X	X	X	X	X	X	X	X	X	X
9	8611-150	Terminal Block DIN Rail	X	X	X	X	X	X	X	X	X	X	X	X
10	8301-096-002*	UPC3-C2 MULTI-TEC	X	X	X	X	X	X	X	X	X	X	X	X
11	8401-037	Contactor 3 Pole 30 Amp w/Aux. Contact		X	X	X	X	X		X	X		X	X
11	8401-038	Contactor 2 Pole 40 Amp w/Aux. Contact	X						X			X		
12	8301-075	USB Micro Cable Female to Male	X	X	X	X	X	X	X	X	X	X	X	X
13	8407-065	Transformer 208/240-24 75VA	X	X		X	X	X	X			X	X	
13	8407-072	Transformer 460/24VAC 75VA			X						X			X
14	8611-144	End Clamp for DIN Rail	4	4	4	4	4	4	4	4	4	4	4	4
15	8607-017	Terminal Block 240V 2 Terminal	X	X	X	X	X	2	X	X	X	X	X	X
16	8611-194	Jumper 2 Position	X	X	X	X	X	X	X	X	X	X	X	X
17	8611-195	Jumper 4 Position	X	X	X	X	X	X	X	X	X	X	X	X
18	8611-151	Terminal Block End Cap for DIN Rail	X	X	X	X	X	X	X	X	X	X	X	X
19	8552-004	Capacitor 7-1/2MFD 370V 1-1/4" O			X		X				X			X
19	8552-005	Capacitor 10MFD 370V1-1/4" O		X		X		X		X			X	
19	8552-089	Capacitor 70/10 MFD 370V	X						X			X		
20	8611-147	3-Pin Circuit Board Connector	X	X	X	X	X	X	X	X	X	X	X	X
21	8611-148	4-Pin Circuit Board Connector	X	X	X	X	X	X	X	X	X	X	X	X
22	8611-149	9-Pin Circuit Board Connector	X	X	X	X	X	X	X	X	X	X	X	X
23	8611-185	8-Pin Circuit Board Connector	X	X	X	X	X	X	X	X	X	X	X	X
25	8611-192	3-Pin Circuit Board Connector	X	X	X	X	X	X	X	X	X	X	X	X
26	8611-183	2-Pin Circuit Board Connector	X	X	X	X	X	X	X	X	X	X	X	X
27	8614-058	2-Pole Fuse Holder						X						
27	8614-042	7 Amp Class CC Fuse						2						
NS	8611-210	2-1/2" DIN Rail						X						
NS	4207-109	Wiring Diagram	X									X		
NS	4207-110	Wiring Diagram							X					
NS	4207-209	Wiring Diagram		X		X							X	
NS	4207-210	Wiring Diagram								X				
NS	4207-309	Wiring Diagram			X									X
NS	4207-310	Wiring Diagram									X			
NS	4207-610	Wiring Diagram				X								
NS	4207-705	Wiring Diagram					X							

* Replacement part will have a letter attached to the end of the part number to designate software version (Example: 8301-096-002A). A software upgrade of all PLCs onsite (units and controllers) should accompany any PLC replacement. Latest revisions of software, change log and instructions are available on the Bard website at <http://www.bardhvac.com/software-download/>

NS = Not Shown

CONTROL PANEL

Dwg No.	Part Number	Description	W60ACPA	W60ACPB	W60ACPC	W60ACPE	W60ACPF	W60ACPQ	W60ACMA	W60ACMB	W60ACMC	W60ACEA	W60ACEB	W60ACEC
1	117-417	Control Panel Assembly	X	X	X	X	X	X	X	X	X	X	X	X
3	135-394	Wire Shield	X	X	X	X	X	X	X	X	X	X	X	X
4	8607-055	Terminal Designation (11-20)	X	X	X	X	X	X	X	X	X	X	X	X
5	8607-056	Terminal Designation (1-10)	X	X	X	X	X	X	X	X	X	X	X	X
6	8201-174BX	3 Phase Line Monitor 50/60 HZ		X	X	X	X		X	X		X	X	
7	8201-130	Relay, SPDT, Pilot Duty	X	X	X	X	X	X	X	X	X	X	X	X
8	8201-176BX	Compressor Control Module	X	X	X	X	X	X	X	X	X	X	X	X
9	8611-150	Terminal Block DIN Rail	X	X	X	X	X	X	X	X	X	X	X	X
10	8301-096-002*	UPC3-C2 MULTI-TEC	X	X	X	X	X	X	X	X	X	X	X	X
11	8401-037	Contactor 3 Pole 30 Amp w/Aux. Contact		X	X	X	X		X	X		X	X	
11	8401-038	Contactor 2 Pole 40 Amp w/Aux. Contact	X						X			X		
12	8301-075	USB Micro Cable Female to Male	X	X	X	X	X	X	X	X	X	X	X	X
13	8407-065	Transformer 208/240-24 75VA	X	X		X	X	X	X		X	X		
13	8407-072	Transformer 460/24VAC 75VA			X						X			X
14	8611-144	End Clamp for DIN Rail	4	4	4	4	4	4	4	4	4	4	4	4
15	8607-017	Terminal Block 240V 2 Terminal	X	X	X	X	X	2	X	X	X	X	X	X
16	8611-194	Jumper 2 Position	X	X	X	X	X	X	X	X	X	X	X	X
17	8611-195	Jumper 4 Position	X	X	X	X	X	X	X	X	X	X	X	X
18	8611-151	Terminal Block End Cap for DIN Rail	X	X	X	X	X	X	X	X	X	X	X	X
19	8552-004	Capacitor 7-1/2MFD 370V 1-1/4" O			X	X				X				X
19	8552-005	Capacitor 10MFD 370V1-1/4" O		X		X				X			X	
19	8552-089	Capacitor 70/10 MFD 370V	X						X			X		
20	8611-147	3-Pin Circuit Board Connector	X	X	X	X	X	X	X	X	X	X	X	X
21	8611-148	4-Pin Circuit Board Connector	X	X	X	X	X	X	X	X	X	X	X	X
22	8611-149	9-Pin Circuit Board Connector	X	X	X	X	X	X	X	X	X	X	X	X
23	8611-185	8-Pin Circuit Board Connector	X	X	X	X	X	X	X	X	X	X	X	X
25	8611-192	3-Pin Circuit Board Connector	X	X	X	X	X	X	X	X	X	X	X	X
26	8611-183	2-Pin Circuit Board Connector	X	X	X	X	X	X	X	X	X	X	X	X
27	8614-058	2-Pole Fuse Holder						X						
27	8614-042	7 Amp Class CC Fuse						2						
NS	8611-210	2-1/2" DIN Rail						X						
NS	4207-109	Wiring Diagram	X									X		
NS	4207-110	Wiring Diagram							X					
NS	4207-209	Wiring Diagram		X		X							X	
NS	4207-210	Wiring Diagram								X				
NS	4207-309	Wiring Diagram			X									X
NS	4207-310	Wiring Diagram								X				
NS	4207-610	Wiring Diagram				X								
NS	4207-706	Wiring Diagram					X							

* Replacement part will have a letter attached to the end of the part number to designate software version (Example: 8301-096-002A). A software upgrade of all PLCs onsite (units and controllers) should accompany any PLC replacement. Latest revisions of software, change log and instructions are available on the Bard website at <http://www.bardhvac.com/software-download/>

NS = Not Shown

CONTROL PANEL

Dwg No.	Part Number	Description	W72ACPA	W72ACPB	W72ACPC	W72ACPF	W72ACPQ	W72ACMA	W72ACMB	W72ACMC	W72ACEA	W72ACEB	W72ACEC
1	117-417	Control Panel Assembly	X	X	X	X	X	X	X	X	X	X	X
3	135-394	Wire Shield	X	X	X	X	X	X	X	X	X	X	X
4	8607-055	Terminal Designation (11-20)	X	X	X	X	X	X	X	X	X	X	X
5	8607-056	Terminal Designation (1-10)	X	X	X	X	X	X	X	X	X	X	X
6	8201-174BX	3 Phase Line Monitor 50/60 HZ		X	X	X	X		X	X		X	X
7	8201-130	Relay, SPDT, Pilot Duty	X	X	X	X	X	X	X	X	X	X	X
8	8201-176BX	Compressor Control Module	X	X	X	X	X	X	X	X	X	X	X
9	8611-150	Terminal Block DIN Rail	X	X	X	X	X	X	X	X	X	X	X
10	8301-096-002*	UPC3-C2 MULTI-TEC	X	X	X	X	X	X	X	X	X	X	X
11	8401-037	Contactor 3 Pole 30 Amp w/Aux. Contact		X	X	X	X		X	X		X	X
11	8401-038	Contactor 2 Pole 40 Amp w/Aux. Contact	X					X			X		
12	8301-075	USB Micro Cable Female to Male	X	X	X	X	X	X	X	X	X	X	X
13	8407-065	Transformer 208/240-24 75VA	X	X		X	X	X		X	X		
13	8407-072	Transformer 460/24VAC 75VA			X					X			X
14	8611-144	End Clamp for DIN Rail	4	4	4	4	4	4	4	4	4	4	4
15	8607-017	Terminal Block 240V 2 Terminal	X	X	X	X	2	X	X	X	X	X	X
16	8611-194	Jumper 2 Position	X	X	X	X	X	X	X	X	X	X	X
17	8611-195	Jumper 4 Position	X	X	X	X	X	X	X	X	X	X	X
18	8611-151	Terminal Block End Cap for DIN Rail	X	X	X	X	X	X	X	X	X	X	X
19	8552-004	Capacitor 7-1/2MFD 370V 1-1/4" O		X					X			X	
19	8552-005	Capacitor 10MFD 370V1-1/4" O			X	X				X			X
19	8552-097	Capacitor 80/7.5 440V 2-1/2" R	X					X			X		
20	8611-147	3-Pin Circuit Board Connector	X	X	X	X	X	X	X	X	X	X	X
21	8611-148	4-Pin Circuit Board Connector	X	X	X	X	X	X	X	X	X	X	X
22	8611-149	9-Pin Circuit Board Connector	X	X	X	X	X	X	X	X	X	X	X
23	8611-185	8-Pin Circuit Board Connector	X	X	X	X	X	X	X	X	X	X	X
25	8611-192	3-Pin Circuit Board Connector	X	X	X	X	X	X	X	X	X	X	X
26	8611-183	2-Pin Circuit Board Connector	X	X	X	X	X	X	X	X	X	X	X
27	8614-058	2-Pole Fuse Holder					X						
27	8614-042	7 Amp Class CC Fuse					2						
NS	8611-210	2-1/2" DIN Rail					X						
NS	4207-109	Wiring Diagram	X								X		
NS	4207-110	Wiring Diagram						X					
NS	4207-209	Wiring Diagram		X								X	
NS	4207-210	Wiring Diagram							X				
NS	4207-309	Wiring Diagram			X								X
NS	4207-310	Wiring Diagram							X				
NS	4207-610	Wiring Diagram				X							
NS	4207-706	Wiring Diagram					X						

* Replacement part will have a letter attached to the end of the part number to designate software version (Example: 8301-096-002A). A software upgrade of all PLCs onsite (units and controllers) should accompany any PLC replacement. Latest revisions of software, change log and instructions are available on the Bard website at <http://www.bardhvac.com/software-download/>

NS = Not Shown

BLOWER ASSEMBLY

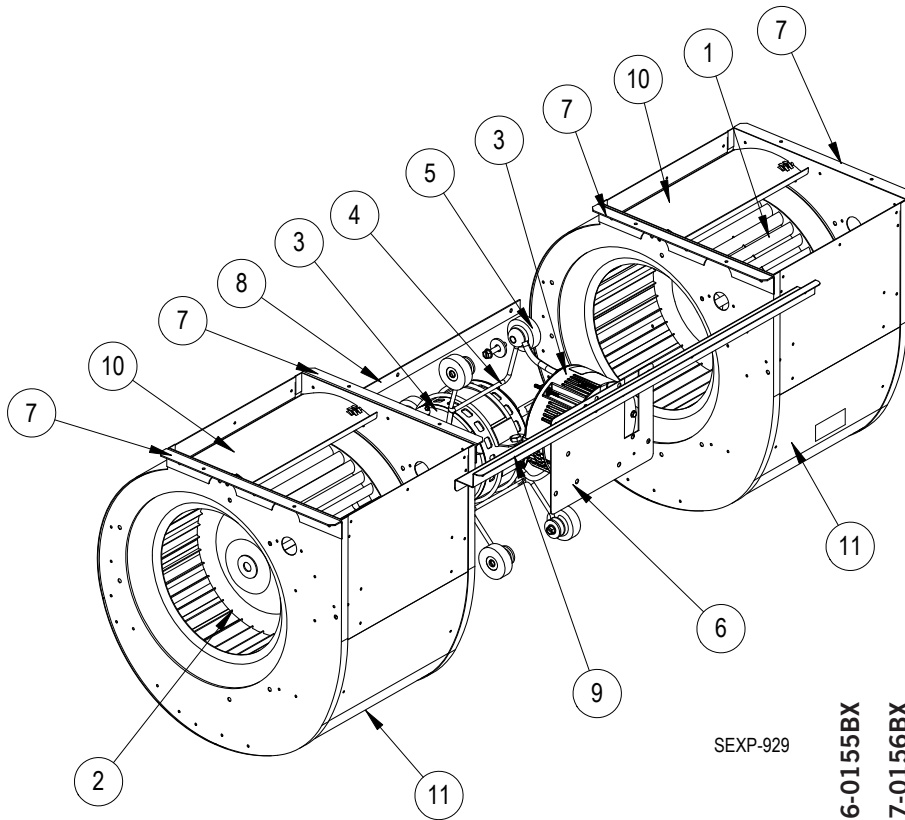

SEXP-929

Dwg No.	Part Number	Description	900-366-0155BX	900-367-0156BX	900-368-0157BX	900-368-0159BX	900-368-0161BX	900-369-0158BX	900-369-0160BX	900-369-0162BX
1	5152-011	10 Inch Wheel (CW)	X	X	X	X	X	X	X	X
2	5152-012	10 Inch Wheel (CW)	X	X	X	X	X	X	X	X
3	S8106-068-0155	Programmed Blower Motor & Control (230/208V)	X							
3	S8106-069-0156	Programmed Blower Motor & Control (460V)		X						
3	S8107-028-0157	Programmed Blower Motor & Control (230/208V)			X					
3	S8107-028-0159	Programmed Blower Motor & Control (230/208V)				X				
3	S8107-028-0161	Programmed Blower Motor & Control (230/208V)					X			
3	S8107-029-0158	Programmed Blower Motor & Control (460V)						X		
3	S8107-029-0160	Programmed Blower Motor & Control (460V)							X	
3	S8107-029-0162	Programmed Blower Motor & Control (460V)								X
3	C8106-074-0155	Programmed Control Only (230/208V)	0							
3	C8106-075-0156	Programmed Control Only (460V)		0						
3	C8107-030-0157	Programmed Control Only (230/208V)			0					
3	C8107-030-0159	Programmed Control Only (230/208V)				0				
3	C8107-030-0161	Programmed Control Only (230/208V)					0			
3	C8107-031-0158	Programmed Control Only (460V)						0		
3	C8107-031-0160	Programmed Control Only (460V)							0	
3	C8107-031-0162	Programmed Control Only (460V)								0
4	8200-040	Motor Mount	X	X	X	X	X	X	X	X
5	5451-011	Grommets	6	6	6	6	6	6	6	6
6	112-775	Motor Control Bracket	X	X	X	X	X	X	X	X
7	105-880	Side Angle	4	4	4	4	4	4	4	4
8	105-881	Back Brace	X	X	X	X	X	X	X	X
9	103-541	Front Mounting Offset	X	X	X	X	X	X	X	X
10	144-166	Diffuser	2	2	2	2	2	2	2	2
11	151-101	Blower Housing	2	2	2	2	2	2	2	2

INTAKE BLADE ASSEMBLY

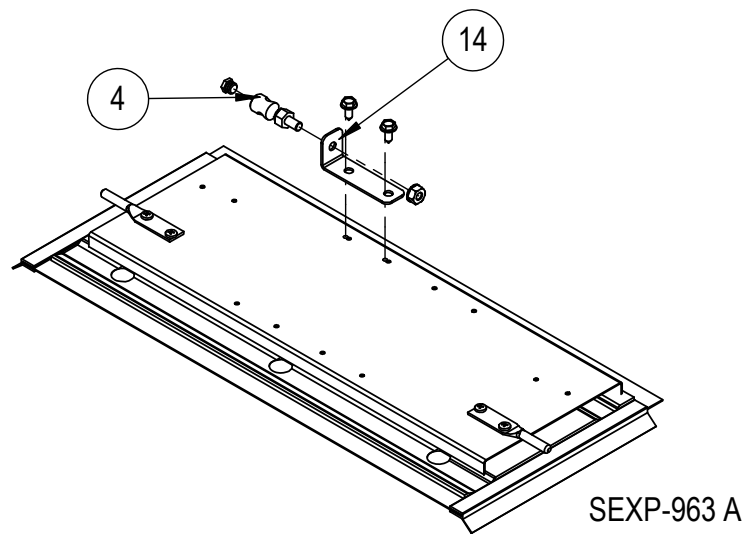
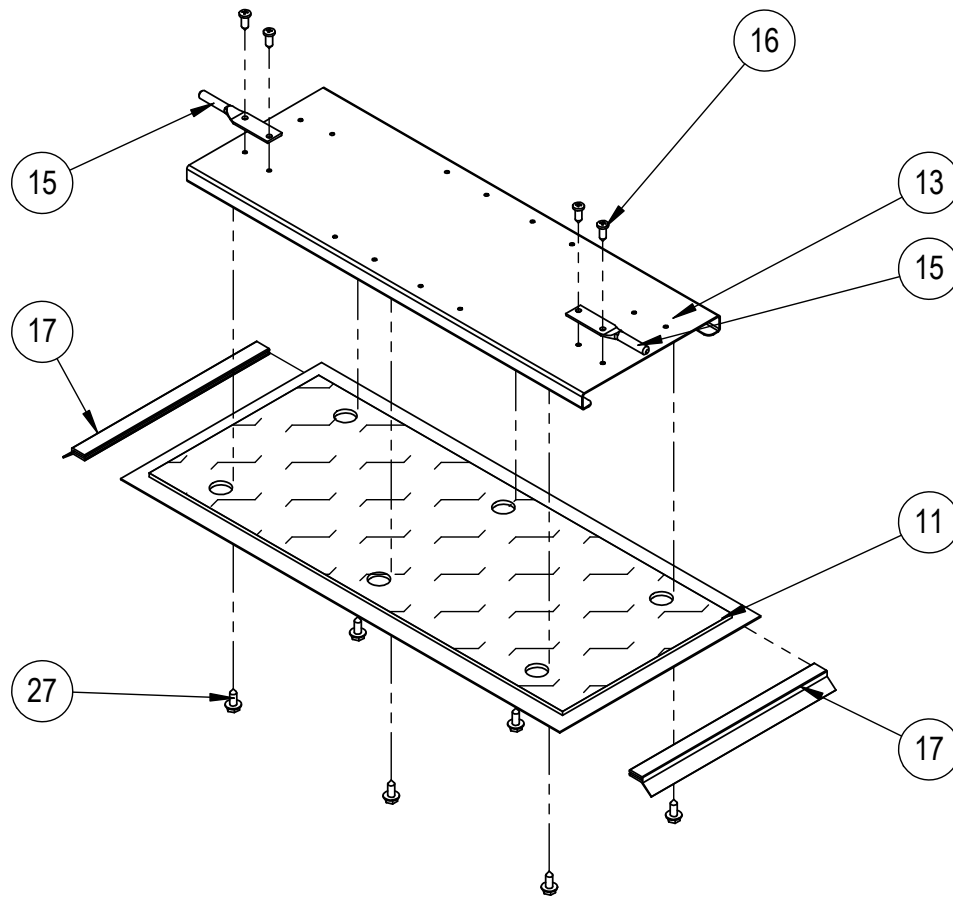

SEXP-963 A

INTAKE BLADE ASSEMBLY

Drawing No.	Part No.	Description	
4	8602-008	BALL JOINT	X
11	138-419	INTAKE BLADE	X
12	1913-125	INSULATION	X
13	141-496	INTAKE BLADE SUPPORT	X
14	113-772	BALL JOINT MOUNTING BRACKET	X
15	8602-106	1/4" ROUND END BEARING	2
17	1921-067-0700	7" DAMPER BLADE SEAL	2

ACTUATOR ASSEMBLY

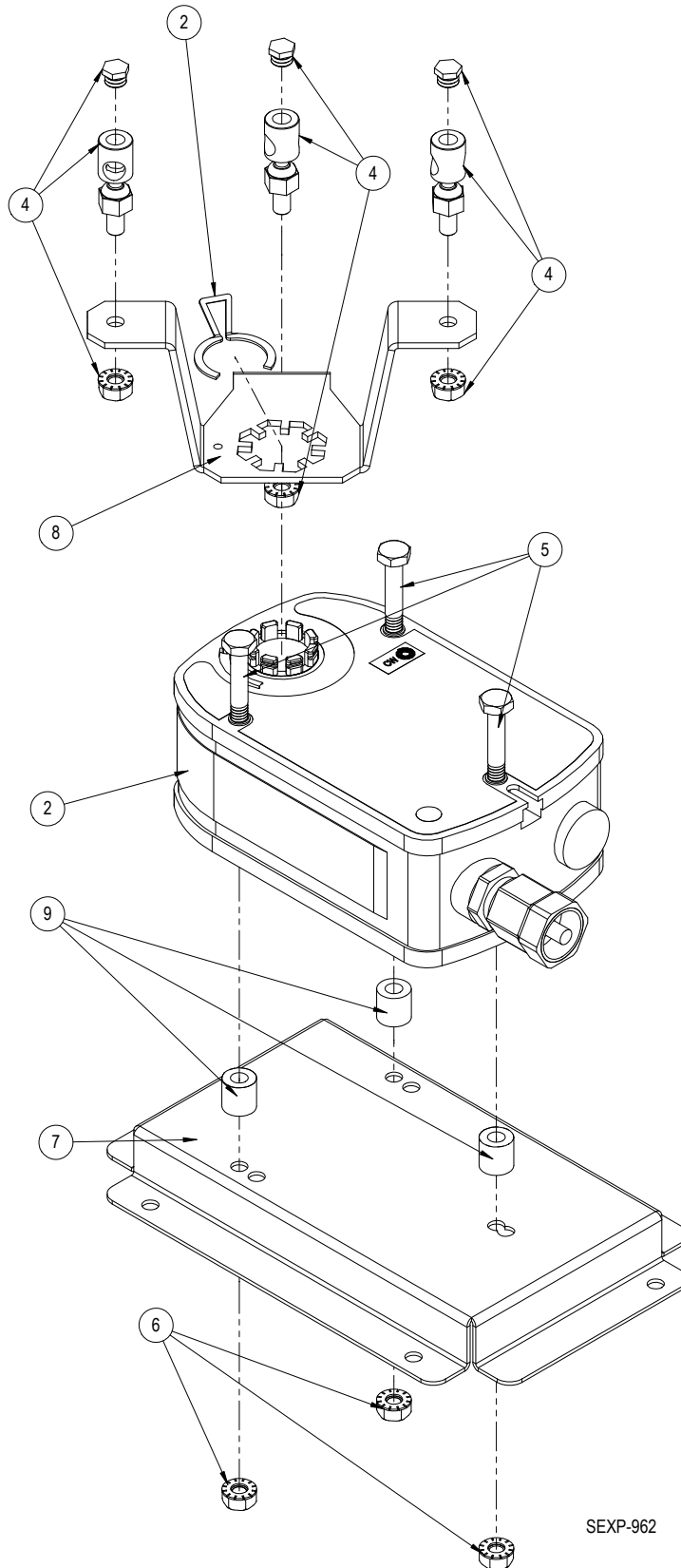

ACTUATOR ASSEMBLY

Drawing No.	Part No.	Description	
2	8602-075	DIRECT COUPLED ACTUATOR	X
4	8602-008	BALL JOINTS	3
5	1012-174	1/4"-20X3-1/4 HEX - CAP SCREW	3
6	1012-201	1/4-20 STEEL KEPS HEX NUT ZINC	3
7	141-495	ACTUATOR SUPPORT PLATE	X
8	139-432	ACTUATOR TRI-ARM	X
9	5451-029	NYLON SLEEVE .257" I.D. X .5" LONG	3

BASE ASSEMBLY AND EXHAUST BLADE ASSEMBLY

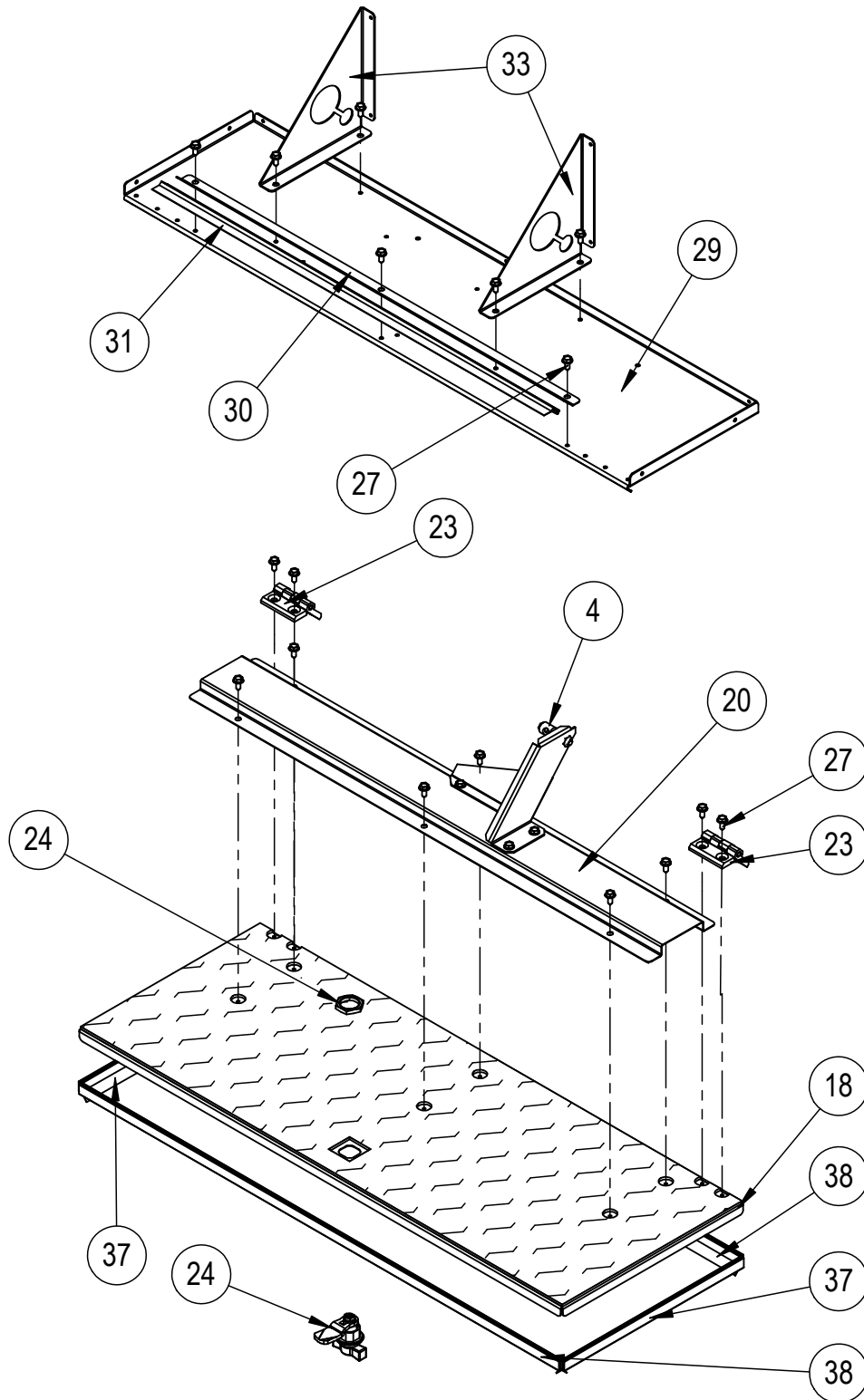

SEXP-961

BASE ASSEMBLY AND EXHAUST BLADE ASSEMBLY

Drawing No.	Part No.	Description	
4	8602-008	BALL JOINT	X
18	139-420	EXHAUST BLADE	X
19	1913-126	INSULATION	X
20	141-497	EXHAUST BLADE SUPPORT	X
21	139-421	EXHAUST BLADE ARM	X
23	5400-010	METAL DBL LEAF HINGE 50 X 50MM	2
24	1171-072	1/4 TURN - WING KNOB LATCH	X
29	127-578	BASE	X
30	105-1461	EXHAUST SEAL ANGLE	X
31	1921-067-2303	23-3/16" DAMPER BLADE SEAL	X
33	141-499	BASE SUPPORT GUSSET	2
37	1921-067-1010	10-5/8" DAMPER BLADE SEAL	2
38	1921-067-2806	28-3/8" DAMPER BLADE SEAL	2

EXHAUST PARTITION ASSEMBLY/INTAKE SEAL ANGLE ASSEMBLY

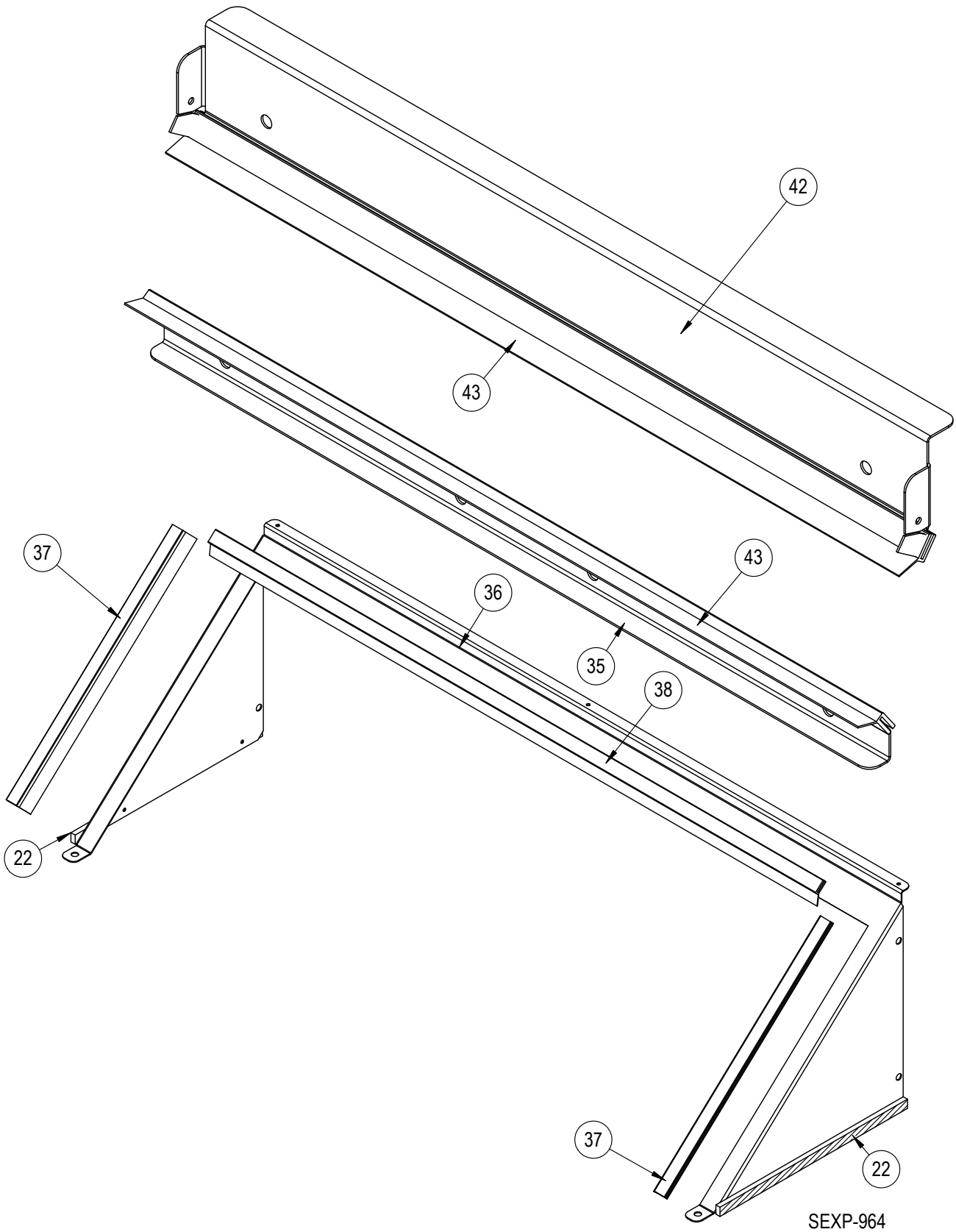

EXHAUST PARTITION ASSEMBLY/INTAKE SEAL ANGLE ASSEMBLY

Drawing No.	Part No.	Description	
22	1913-079-0812	8-3/4" SFO W/PSA .197 X .375	2
35	105-1460	LOWER INTAKE SEAL ANGLE	X
36	139-422	EXHAUST FRAME	X
37	1921-067-1010	10-5/8" DAMPER BLADE SEAL	2
38	1921-067-2806	28-3/8" DAMPER BLADE SEAL	X
42	105-1459	UPPER INTAKE SEAL ANGLE	X
43	1921-067-1614	16-7/8" DAMPER BLADE SEAL	X

VENT ASSEMBLY

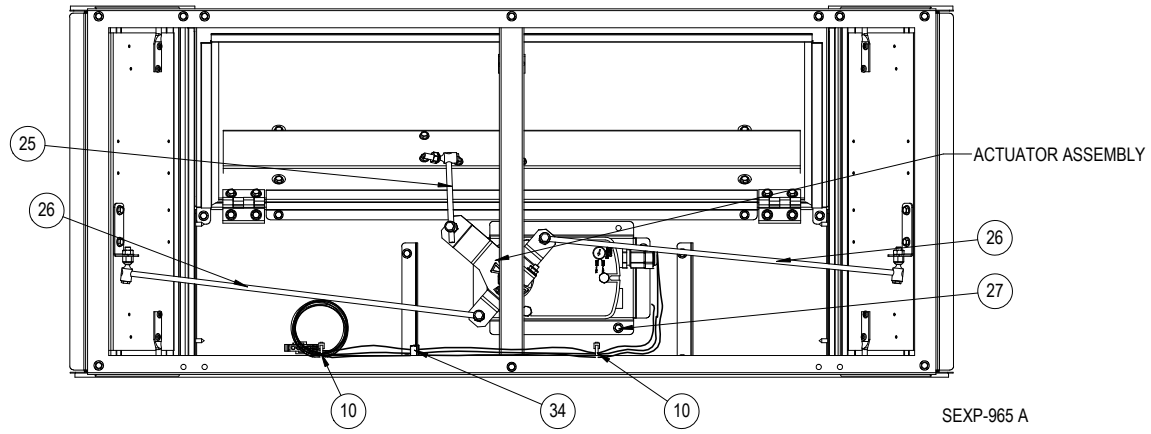
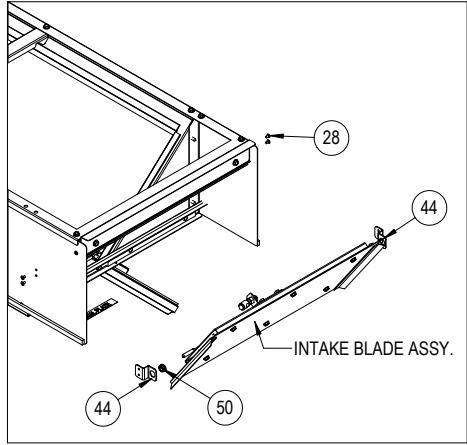
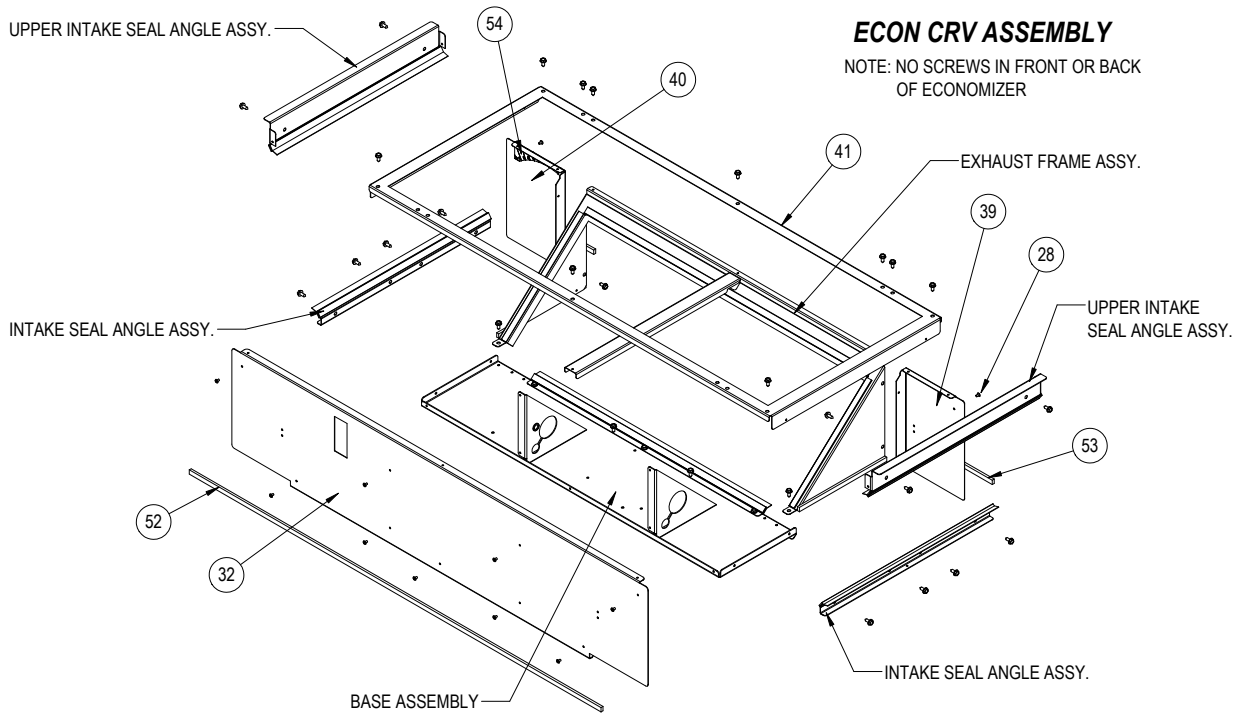

VENT ASSEMBLY

Drawing No.	Part No.	Description	
10	7950-012	PUSH MOUNT CABLE TIE 6-1/8"	2
25	8602-104	1/4 X 4-1/4" ROD	X
26	8602-105	1/4 X 17-1/4" ROD	2
32	115-332	FRONT	X
34	8611-047	OPEN/CLOSE SNAP BUSHING 3/4"	X
39	139X424	REAR INTAKE PARTITION - RH	X
40	139Y424	REAR INTAKE PARTITION - LH	X
41	107-385	TOP	X
44	113-773	DAMPER PIVOT BRACKET	4
50	8611-239	1/2" SNAP-IN SMOOTH BORE BSHNG	4
52	1913-079-4104	41-1/4" SFO W/PSA .197 X .375	X
53	1913-079-0514	5-7/8" SFO W/PSA .197 X .375	2
54	7961-904	CRVV-5 Position Label	X
NS	7003-084	MIST FILTER	2
NS	7003-083	EXHAUST BUG SCREEN	X
NS	543-223	SIDE VENT BLOCK OFF PLATE ASSEMBLY	2
NS	539-405	INTAKE SEALING FRAME	2
NS	8406-150	MAGNETIC REED SWITCH	X
NS	4056-246	WIRING DIAGRAM	X