REPLACEMENT PARTS MANUAL

MEGA-TEC® Wall Mount Air Conditioner

Models:

W180BPS W180BES
W180BPT W180BET
W180BPN W180BEN
W180BPQ W180BEQ

Contents

Description	Page	Description	Page
External Parts		Electric Heat Components	
♦ Exploded View	2	♦ Exploded View	26
♦ Usage List	3	♦ Usage List	27
♦ Usage List	4	Right and Left Intake Damper Assemblies	
Internal Parts		♦ Exploded View	28
♦ Exploded View	6	♦ Usage List	29
♦ Usage List	7	Right and Left Exhaust Damper Assembly	
♦ Usage List	8	♦ Exploded View	30
Economizer Intake Hoods		♦ Usage List	31
♦ Exploded View	10	Exhaust Damper Actuator Assemblies	
♦ Usage List	11	♦ Exploded View	32
System Components		♦ Usage List	32
♦ Layout View	12	575V Transformer Assembly	
♦ Usage List	13	♦ Exploded View	33
Fan System Components		♦ Usage List	33
♦ Exploded View	14		
♦ Usage List	15		
Sensors and Peripheral Devices			
♦ Layout View	16		
♦ Usage List	17		
Control Panel – S Voltage			
♦ Layout View	18		
♦ Usage List	19		
♦ Usage List	20		
Control Panel – T, Q & N Voltage			
♦ Layout View	22		
♦ Usage List	23		
♦ Usage List	24		

General Notes

- Revised and/or additional pages may be issued from time to time.
- A complete and current manual consists of pages shown in the following contents section.

Important

- Contact the installing and/or local Bard distributor for all parts requirements. Make sure to have the complete model and serial number available from the unit rating plates.



Bard Manufacturing Company, Inc.
Bryan, Ohio 43506
www.bardvac.com

Manual: 2110-1466D
Supersedes: 2110-1466C
Date: 10-25-21

EXTERNAL PARTS

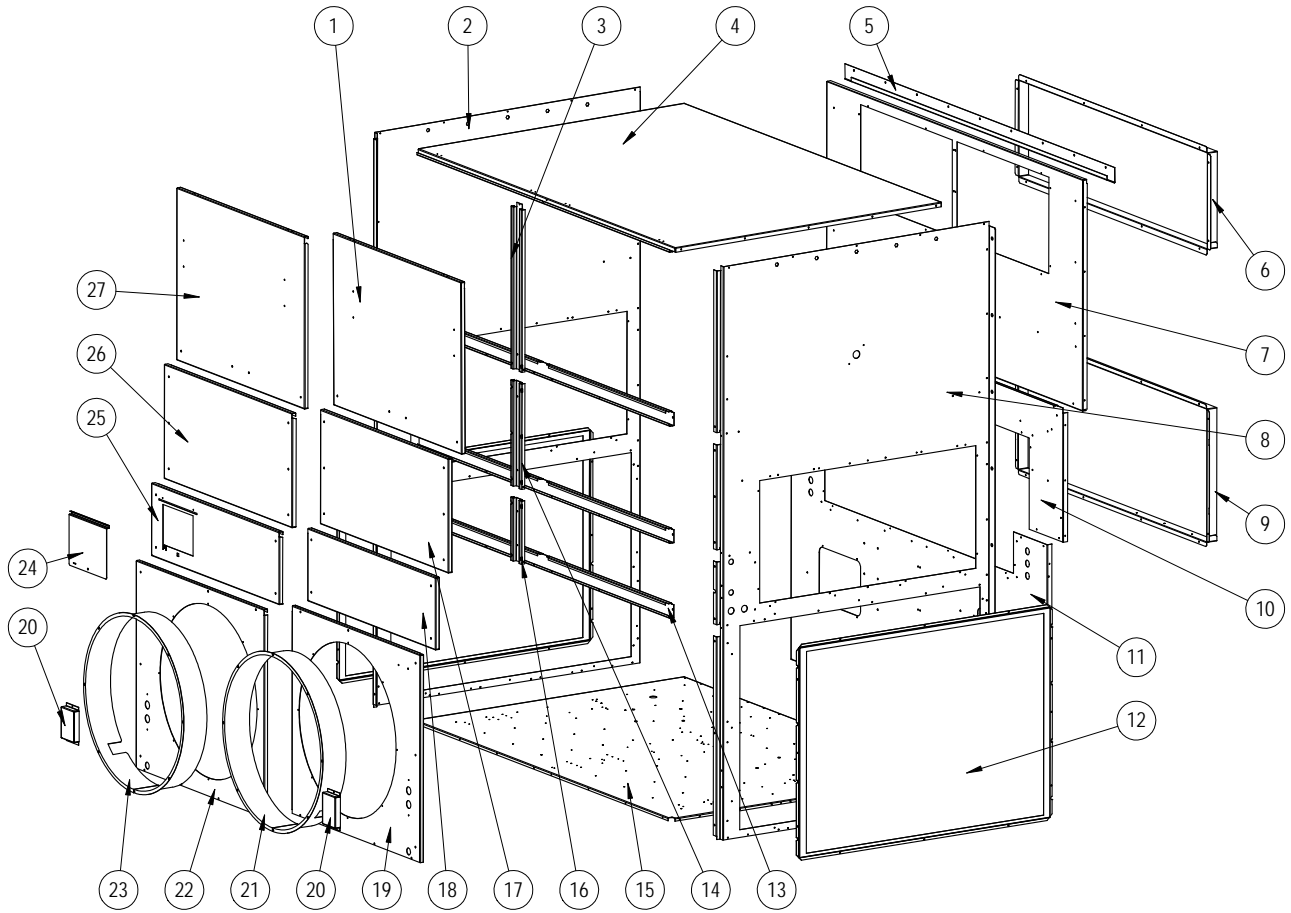

SEXP-1043

This drawing to be used for reference for pages 3 and 4

EXTERNAL PARTS

Dwg No.	Part Number	Description	W180B****E	W180B****B
1	S553-743-* ①	Evaporator Door Assembly RH (with Hinges)	X	X
1	S553-761 ②	Evaporator Door Assembly RH (with Hinges)	X	X
2	S501-1097-* ①	Left Side Assembly (Economizer)	X	
2	S501-1124 ②	Left Side Assembly (Economizer)	X	
2	S501-1109-* ①	Left Side Assembly (Non-Economizer)		X
2	S501-1126 ②	Left Side Assembly (Non-Economizer)		X
3	145-208-* ①	Rain Channel Evap	X	X
3	145-209 ②	Rain Channel Evap	X	X
4	507-398-* ①	Top Assembly	X	X
4	507-406 ②	Top Assembly	X	X
5	113-872-* ①	Rain Flashing	X	X
5	113-917 ②	Rain Flashing	X	X
6	111-331	Supply Air Frame	2	2
7	509-439	Upper Back Assembly	X	X
7	509-466 ②	Upper Back Assembly	X	X
8	S501-1096-* ①	Right Side Assembly (Economizer)	X	
8	S501-1123 ②	Right Side Assembly (Economizer)	X	
8	S501-1108-* ①	Right Side Assembly (Non-Economizer)		X
8	S501-1125 ②	Right Side Assembly (Non-Economizer)		X
9	111-330	Return Air Frame	2	2
10	509-440	Middle Back Assembly (Economizer)	X	
10	509-468 ②	Middle Back Assembly (Economizer)	X	
10	509-458	Middle Back Assembly (Non-Economizer)		X
10	509-469 ②	Middle Back Assembly (Non-Economizer)		X
11	109-441	Lower Back	X	X
11	109-467 ②	Lower Back	X	X
12	118-150-* ①	Condenser Grille	2	2
12	118-154 ②	Condenser Grille	2	2
13	135-404-* ①	Rain Channel Horizontal	3	3
13	135-414 ②	Rain Channel Horizontal	3	3
14	135-407-* ①	Rain Channel Blower	X	X
14	135-416 ②	Rain Channel Blower	X	X
15	527-597	Base Assembly	X	X
15	527-606 ②	Base Assembly	X	X
16	135-406-* ①	Rain Channel CP	X	X
16	135-415 ②	Rain Channel CP	X	X
17	S553-749-* ①	Blower Door Assembly RH	X	X
17	S553-759 ②	Blower Door Assembly RH	X	X
18	533-326-* ①	Control Panel Door Assembly RH	X	X
18	533-353 ②	Control Panel Door Assembly RH	X	X
19	S553-744-* ①	Condenser Door Assembly RH (includes Venturi Ring and Service Port Cover)	X	X
19	S553-757 ②	Condenser Door Assembly RH (includes Venturi Ring and Service Port Cover)	X	X
20	157-031-* ①	Service Port Cover	2	2
20	157-033 ②	Service Port Cover	2	2
21	167-030-* ①	Right Venturi Ring	X	X
21	167-033 ②	Right Venturi Ring	X	X
22	S553-746-* ①	Condenser Door Assembly LH (includes Venturi Ring and Service Port Cover)	X	X
22	S553-758 ②	Condenser Door Assembly LH (includes Venturi Ring and Service Port Cover)	X	X

Continued on page 4

① Exterior cabinet parts are manufactured with various paint color options. To ensure the proper paint color is received, include the complete model and serial number of the unit for which cabinet parts are being ordered.

② Cabinet components are manufactured from stainless steel Code "S"

EXTERNAL PARTS

W180B****E
W180B****B

Dwg No.	Part Number	Description		
<i>Continued from page 3</i>				
23	167-032-* ①	Left Venturi Ring	X	X
23	167-034 ②	Left Venturi Ring	X	X
24	S153-745-* ①	Control Panel Access Door	X	X
24	S153-763 ②	Control Panel Access Door	X	X
25	S533-325-* ①	Control Panel Door Assembly LH (includes Control Panel Access Door)	X	X
25	S533-354 ②	Control Panel Door Assembly LH (includes Control Panel Access Door)	X	X
26	S553-748-* ①	Blower Door Assembly LH	X	X
26	S553-760 ②	Blower Door Assembly LH	X	X
27	S553-747-* ①	Evaporator Door Assembly LH (with Hinges)	X	X
27	S553-762 ②	Evaporator Door Assembly LH (with Hinges)	X	X
NS	S400-0465	Handle Kit	X	X
NS	5252-033	Bard Nameplate	X	X

- ① Exterior cabinet parts are manufactured with various paint color options. To ensure the proper paint color is received, include the complete model and serial number of the unit for which cabinet parts are being ordered.
- ② Cabinet components are manufactured from stainless steel Code "S"
- NS – Not Shown

Refer to drawing on page 2

This page intentionally left blank

INTERNAL PARTS

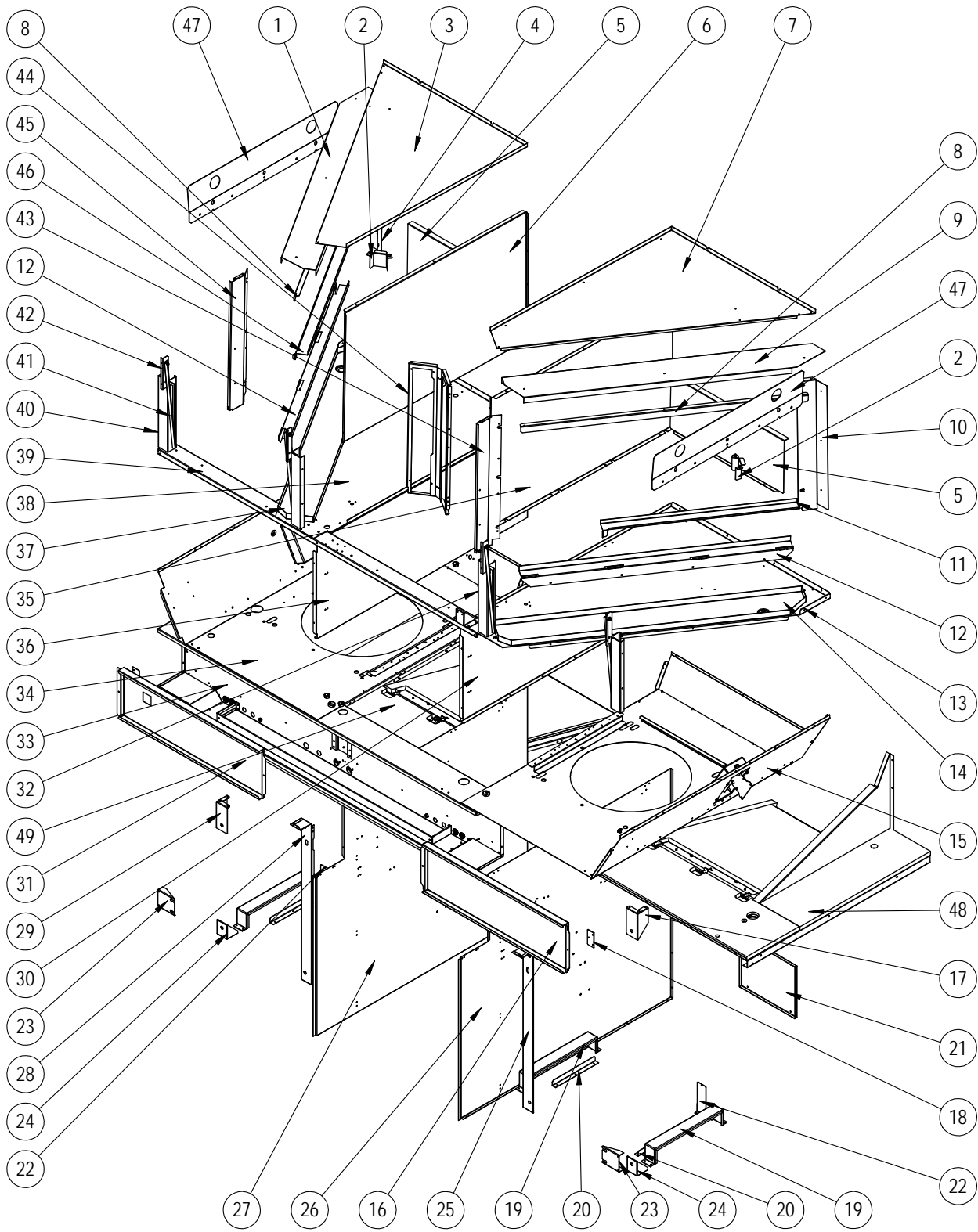

SEXP-1053

This drawing to be used for reference for pages 7 and 8

INTERNAL PARTS

Dwg No.	Part Number	Description	W180B***E	W180B***B
1	137Y997	Filter Retainer LH	X	X
2	113-897	Electric Heat Frame Support	2	2
3	521Y620	Evaporator Cap Assembly LH (includes Electric Heat Frame Support)	X	X
4	541-535	Evaporator Support Bracket Assembly Rear LH	X	X
5	135-405	Insulation Shield	2	2
6	121Y619	Center Partition Evaporator Assembly LH	X	X
7	521X620	Evaporator Cap Assembly RH (includes Electric Heat Frame Support)	X	X
8	105-1512	Filter Angle	2	2
9	137X997	Filter Retainer RH	X	X
10	541-534	Evaporator Support Bracket Assembly Rear LH	X	X
11	131X177	Filter Removal Tray RH	X	X
12	103-548	Filter Offset	2	2
13	521X631	Evaporator Partition Assembly RH	X	X
14	523-168	Drain Pan Assembly RH	X	X
15	S521-612	Blower Partition Assembly RH (Economizer)	X	
15	S521-628	Blower Partition Assembly RH (Non-Economizer)		X
16	S133-335	Control Panel Cover (Inner) RH	X	X
17	113X878	Fan Mount - Upper RH	X	X
17	113X921 ①	Fan Mount - Upper RH	X	X
18	113-889	Control Panel Cover Support	2	2
19	113-735	Wheel Slide	4	4
19	113-840 ①	Wheel Slide	4	4
20	113-738	Track Guide	4	4
20	113-841 ①	Track Guide	4	4
21	143-231	Back Access Cover	2	2
21	143-249 ①	Back Access Cover	2	2
22	113-874	Filter Drier Bracket	2	2
22	113-928 ①	Filter Drier Bracket	2	2
23	113-869	Service Port Bracket	2	2
23	113-915 ①	Service Port Bracket	2	2
24	113-875	Fan Mount - Lower	2	2
24	113-918 ①	Fan Mount - Lower	2	2
25	113X865	Fan Mounting Bracket RH	X	X
25	113X920 ①	Fan Mounting Bracket RH	X	X
26	121X615	Center Partition - Condenser RH	X	X
26	121X637 ①	Center Partition - Condenser RH	X	X
27	121Y615	Center Partition - Condenser LH	X	X
27	121Y637 ①	Center Partition - Condenser LH	X	X
28	113Y865	Fan Mounting Bracket LH	X	X
28	113Y920 ①	Fan Mounting Bracket LH	X	X
29	113Y878	Fan Mount - Upper LH	X	X
29	113Y921 ①	Fan Mount - Upper LH	X	X
30	121X617	Center Partition - Blower RH	X	X
31	S133-327	Control Panel Cover (Inner) LH (2) CB or (2) Disconnects	X	X
31	S133-328	Control Panel Cover (Inner) LH 230V (3) CB	X	X
31	S133-328	Control Panel Cover (Inner) LH 460V (1) Disconnect	X	X

Continued on page 8

① Internal parts are manufactured from stainless steel Code "S"

INTERNAL PARTS

Dwg No.	Part Number	Description	W180B****E	W180B****B
<i>Continued from page 7</i>				
32	113X876	Evaporator Door Support Guide RH	X	X
33	517-431	Control Panel Assembly (Economizer)	X	
33	517-442 ①	Control Panel Assembly (Economizer)	X	
33	517-438	Control Panel Assembly (Non- Economizer)		X
33	517-443 ①	Control Panel Assembly (Non- Economizer)		X
34	S521-632	Blower Partition Assembly LH (Economizer)	X	
34	S521-633	Blower Partition Assembly LH (Non-Economizer)		X
35	521X619	Center Partition Evaporator Assembly RH	X	X
36	121Y617	Center Partition - Blower LH	X	X
37	523-167	Drain Pan Assembly LH	X	X
38	521Y631	Evaporator Partition Assembly LH	X	X
39	141-528	Evaporator Horizontal Support	X	X
40	113Y876	Evaporator Door Support Guide LH	X	X
41	113-733	Evaporator Door Hinge Arm	2	2
42	113-732	Evaporator Door Arm Bracket	2	2
43	141X530	Evaporator Coil Front Support RH	X	X
44	141-533	Electric Heat Bracket	X	X
45	141Y530	Evaporator Coil Front Support LH	X	X
46	131Y177	Filter Removal Tray LH	X	X
47	113-870	Lifting Bracket	2	2
47	113-916 ①	Lifting Bracket	2	2
48	521X622	Condenser Partition Assembly RH (Economizer)	X	
48	521X638 ①	Condenser Partition Assembly RH (Economizer)	X	
48	521X629	Condenser Partition Assembly RH (Non-Economizer)		X
48	521X639 ①	Condenser Partition Assembly RH (Non-Economizer)		X
49	521Y622	Condenser Partition Assembly LH (Economizer)	X	
49	521Y638 ①	Condenser Partition Assembly LH (Economizer)	X	
49	521Y629	Condenser Partition Assembly LH (Non-Economizer)		X
49	521Y639 ①	Condenser Partition Assembly LH (Non-Economizer)		X
NS	113X879	Air Deflector RH (Non-Economizer)		X
NS	113Y879	Air Deflector LH (Non-Economizer)		X
NS	113-867	Door Switch Bracket	2	2
NS	113-914 ①	Door Switch Bracket	2	2
NS	8550-011	Filter Drier Strap	2	2
NS	8550-014 ①	Filter Drier Strap	2	2

① Internal parts are manufactured from stainless steel Code "S"

NS – Not Shown

Refer to drawing on page 6

This page intentionally left blank

ECONOMIZER INTAKE HOODS

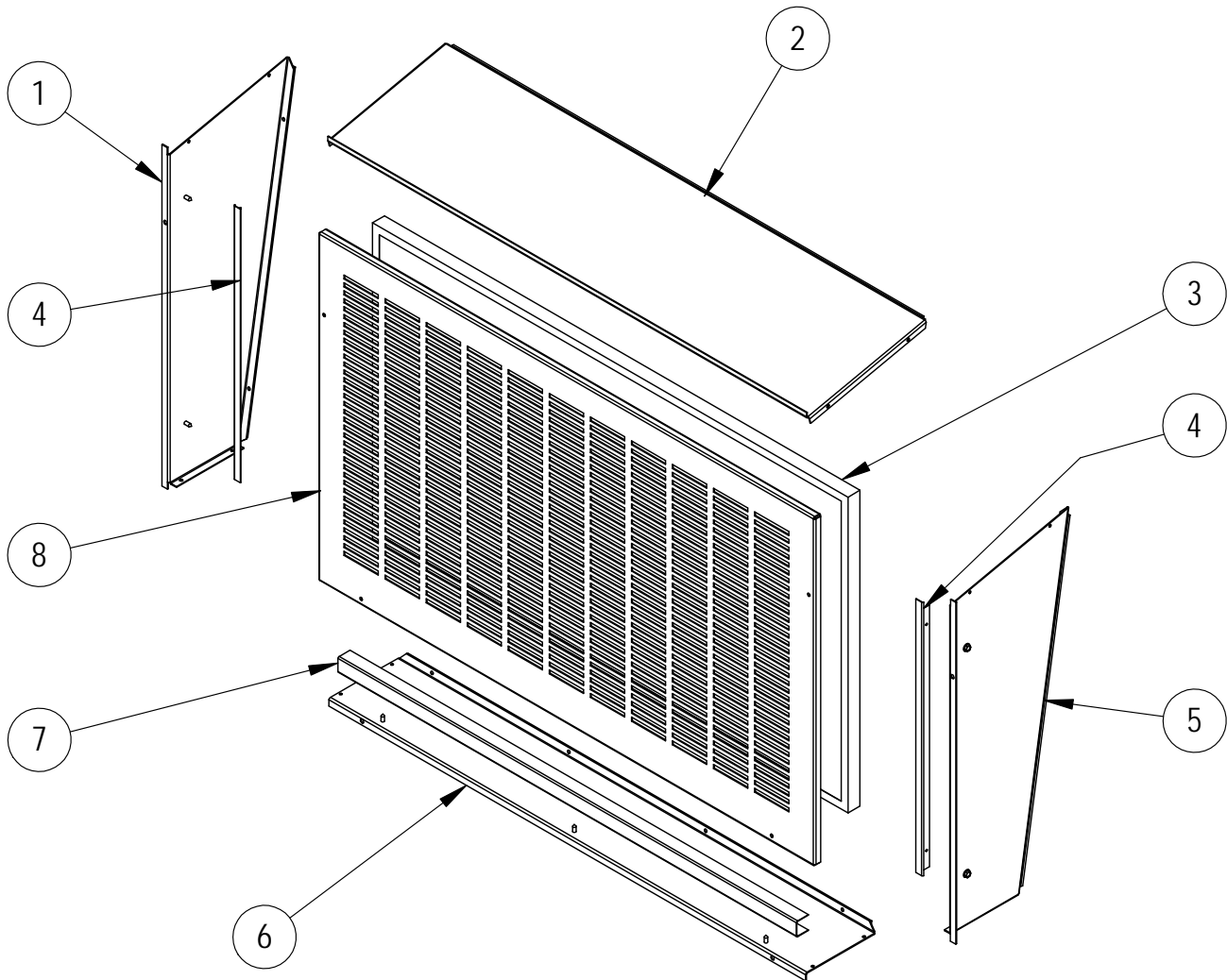

SEXP-899

ECONOMIZER INTAKE HOODS

W180B****E

Dwg No.	Part Number	Description	
1	501-1039-* ①	Economizer Hood Left Side Assembly (includes Side Filter Angle)	X
1	501-1120 ②	Economizer Hood Left Side Assembly (includes Side Filter Angle)	X
2	507-397-* ①	Economizer Top Assembly	X
2	507-405 ②	Economizer Top Assembly	X
3	7003-086	Mist Eliminator	X
4	105-1342	Side Filter Angle	X
4	105-1525 ②	Side Filter Angle	X
5	501-1040-* ①	Economizer Hood Right Side Assembly (includes Side Filter Angle)	X
5	501-1121 ②	Economizer Hood Right Side Assembly (includes Side Filter Angle)	X
6	527-596-* ①	Economizer Hood Base Assembly (includes Mist Eliminator Support)	X
6	527-608 ②	Economizer Hood Base Assembly (includes Mist Eliminator Support)	X
7	113-725	Mist Eliminator Support	X
7	113-901 ②	Mist Eliminator Support	X
8	119-151-* ①	Economizer Grille	X
8	119-155 ②	Economizer Grille	X

① Exterior cabinet parts are manufactured with various paint color options. To ensure the proper paint color is received, include the complete model and serial number of the unit for which cabinet parts are being ordered.

② Economizer intake hood components are manufactured from stainless steel Code "S"

SYSTEM COMPONENTS

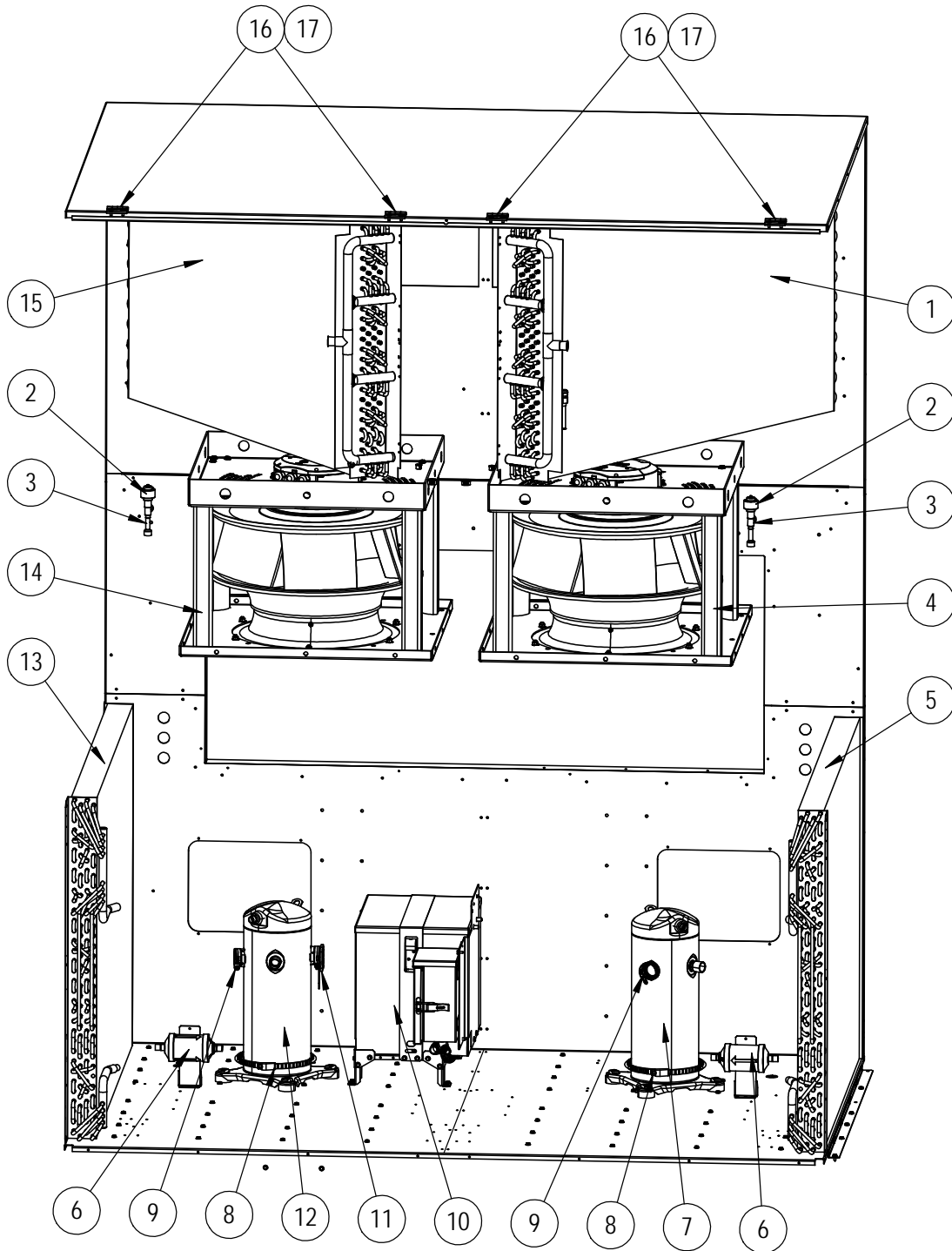

SEXP-1044 A

SYSTEM COMPONENTS

Dwg. No.	Part Number	Description	W180B*S	W180B*T	W180B*N	W180B*Q
1	917-0441BX	Evaporator Coil Assembly RH (Green Hydrophillic Coated)	X	X	X	X
1	917-0452BX	Evaporator Coil Assembly RH (Phenolic Coated)	0	0	0	0
2	5651-246	EEV Cable and Stator	2	2	2	2
3	5651-251	Electronic Expansive Valve	2	2	2	2
4	S900-390-001	Indoor Programmed Blower Assembly RH	X			
4	S900-392-001	Indoor Programmed Blower Assembly RH		X	X	X
5	5051-239BX	Right Condenser Coil	X	X	X	X
5	5054-239BX	Right Condenser Coil (Phenolic Coated)	0	0	0	0
6	5201-026	Refrigerant Filter Drier	2	2	2	2
7	8000-476	1-Stage Compressor (ZP83KCE-TF5-130)	X			
7	8000-474	1-Stage Compressor (ZP83KCE-TFD-130)		X		
7	8000-471	1-Stage Compressor (ZP83KCE-TF7-130)			X	
7	8000-472	1-Stage Compressor (ZP83KCE-TFE-130)				X
8	8605-017	Compressor Crankcase Heater	2			
8	8605-018	Compressor Crankcase Heater		2	2	
8	8605-021	Compressor Crankcase Heater				2
9	3000-1606	Compressor Power Plug	2	2	2	2
10	910-2186	575V Transformer/Junction Box Assembly (see page 33)				X
11	3000-1604	LH Compressor Staging Solenoid Plug	X	X	X	X
12	8000-477	2-Stage Compressor (ZPS83KCE-TF5-130)	X			
12	8000-475	2-Stage Compressor (ZPS83KCE-TFD-130)		X		
12	8000-484	2-Stage Compressor(ZPSS83KCE-TF7-130)			X	
12	8000-473	2-Stage Compressor (ZPS83KCE-TFE-130)				X
13	5051-238BX	Left Condenser Coil	X	X	X	X
13	5054-238BX	Left Condenser Coil (Phenolic Coated)	0	0	0	0
14	S900-389-001	Indoor Programmed Blower Assembly LH	X			
14	S900-391-001	Indoor Programmed Blower Assembly LH		X	X	X
15	917-0442BX	Evaporator Coil Assembly LH (Green Hydrophillic Coated)	X	X	X	X
15	917-0453BX	Evaporator Coil Assembly LH (Phenolic Coated)	0	0	0	0
16	5400-010	Metal Leaf Hinge	4	4	4	4
17	1012-130	Torx Screws (for hinges, 2-per)	8	8	8	8
NS	7004-025	Air Filter 2" MERV 8 (16 x 25 x 2)	6	6	6	6
NS	7004-059	Air Filter 2" MERV 11 (16 x 25 x 2) ①	6	6	6	6
NS	7004-061	Air Filter 2" MERV 13 (16 x 25 x 2) ①	6	6	6	6

NS – Not Shown
 ① – Optional on these models

X – Standard Components
 O – Optional Components

NOTE: Refrigerant pressure switches, transducers and system temperature sensors can be found on pages 16 and 17.

FAN SYSTEM COMPONENTS

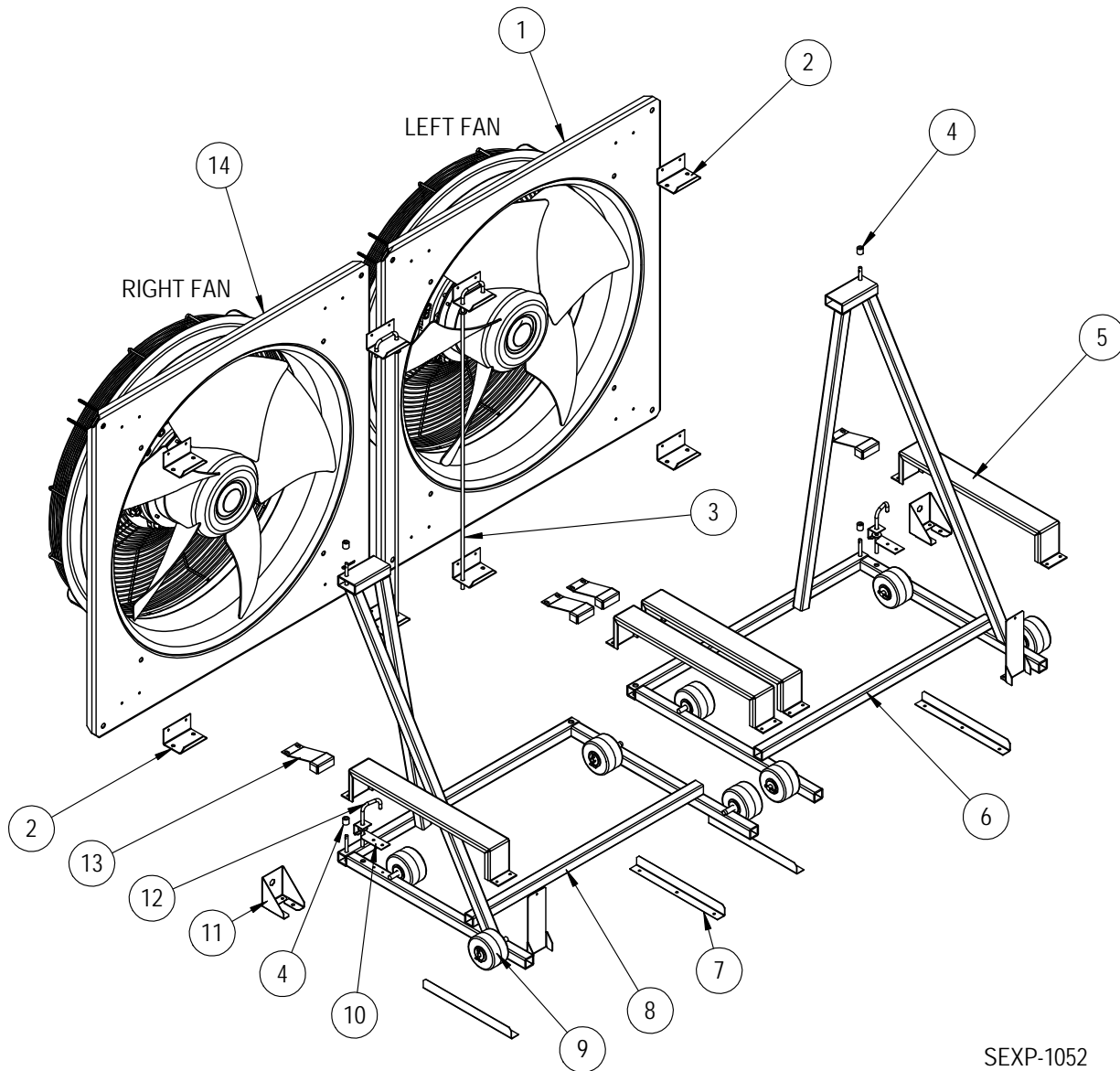
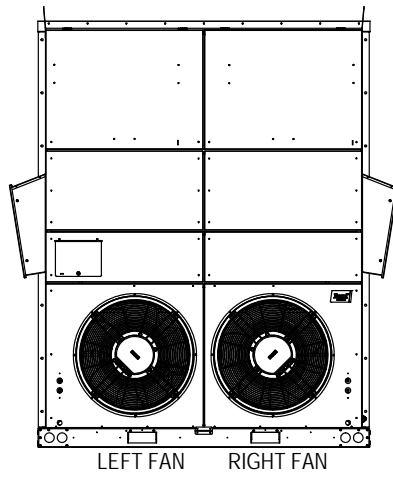

SEXP-1052

FAN SYSTEM COMPONENTS

Dwg No.	Part Number	Description	W180B*S	W180B*T	W180B*N	W180B*Q
1	S922-0004-001	Left Fan & Motor Bracket Assembly (includes Dwg. No. 2 & 3)	X			
1	922-0008-001 ①	Left Fan & Motor Bracket Assembly (includes Dwg. No. 2 & 3)	X			
1	S922-0006-001	Left Fan & Motor Bracket Assembly (includes Dwg. No. 2 & 3)		X	X	X
1	922-0010-001 ①	Left Fan & Motor Bracket Assembly (includes Dwg. No. 2 & 3)		X	X	X
2	113-737	Fan Hinge	8	8	8	8
2	113-898 ①	Fan Hinge	8	8	8	8
3	5401-008	Anti-Pivot Rod	2	2	2	2
4	5451-029	Nylon Sleeve	4	4	4	4
5	113-735	Wheel Slide	4	4	4	4
5	113-840 ①	Wheel Slide	4	4	4	4
6	8200-057	Left Fan Slide Welded Frame	X	X	X	X
6	8200-059 ①	Left Fan Slide Welded Frame	X	X	X	X
7	113-738	Track Guide	4	4	4	4
7	113-841 ①	Track Guide	4	4	4	4
8	8200-056	Right Fan Slide Welded Frame	X	X	X	X
8	8200-058 ①	Right Fan Slide Welded Frame	X	X	X	X
9	1171-035	Plastic Wheel, 3" Diameter	8	8	8	8
10	113-752	Fan Safety Lock Bracket	2	2	2	2
10	113-839 ①	Fan Safety Lock Bracket	2	2	2	2
11	113-875	Fan Mount - Lower	2	2	2	2
11	113-918 ①	Fan Mount - Lower	2	2	2	2
12	5401-007	Fan Stop Rod	2	2	2	2
13	141-541	Fan Wedge Bracket	4	4	4	4
13	141-550 ①	Fan Wedge Bracket	4	4	4	4
14	S922-0005-001	Right Fan & Motor Bracket Assembly (includes Dwg. No. 2 & 3)				
14	922-0009-001 ①	Right Fan & Motor Bracket Assembly (includes Dwg. No. 2 & 3)	X			
14	S922-0007-001	Right Fan & Motor Bracket Assembly (includes Dwg. No. 2 & 3)		X	X	X
14	922-0011-001 ①	Right Fan & Motor Bracket Assembly (includes Dwg. No. 2 & 3)				

① Fan system components are manufactured from stainless steel Code "S"

SENSORS AND PERIPHERAL DEVICES

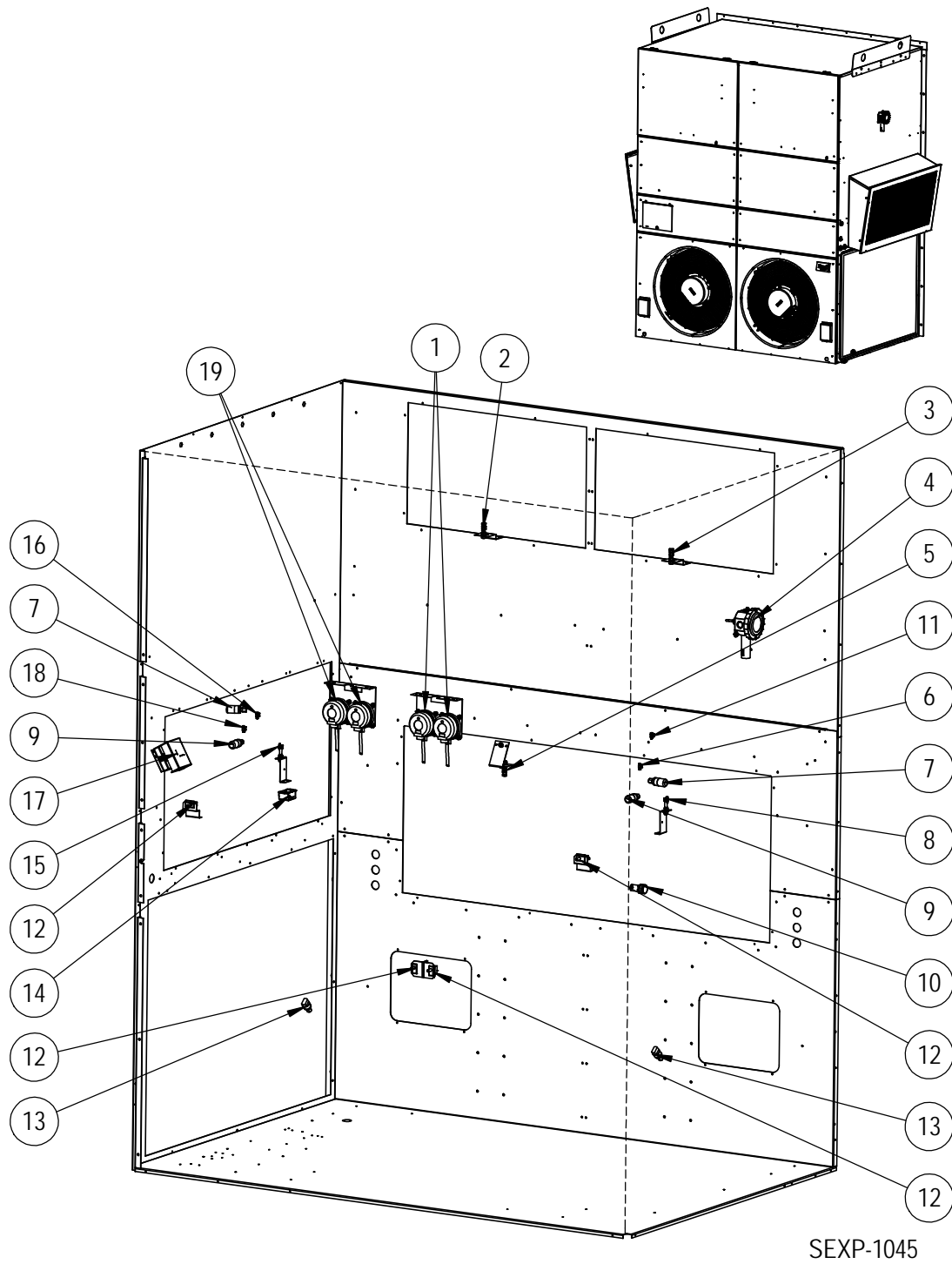

SENSORS AND PERIPHERAL DEVICES

Dwg No.	Part Number	Description	W180B****E	W180B****B
1	8301-104	Filter Switch w/Adjustment (910-2154 RH)	X	X
1	8301-104	Blower Fail Switch w/Adjustment (910-2154 RH)	X	X
2	8620-296	Sensor Replacement Kit (910-2143 LH SAT)	X	X
3	8620-296	Sensor Replacement Kit (910-2144 RH SAT)	X	X
4	8301-089	Outdoor Temp and Humidity Sensor (910-2056)	X	X
5	8620-296	Sensor Replacement Kit (910-2054 RAT)	X	X
6	8620-224	3/8" Defrost Sensor Kit (910-2077 LLT2 Liquid Line Temp Sensor)	X	X
7	8406-158	Low Pressure Transducer - Blue	2	2
8	8620-296	Sensor Replacement Kit (910-2157 MAT2 Mixed Air Sensor)	X	
9	8406-157	High Pressure Transducer - Red	2	2
10	8611-199	Dirty Filter Light	X	X
11	8620-296	Sensor Replacement Kit (910-2076 ST2 Suction Temp Sensor)	X	X
12	8406-156	Door Switch	4	4
13	8406-142	High Pressure Switch	2	2
14	8301-091	Particulate Dust Sensor (910-2088)	X	
15	8620-296	Sensor Replacement Kit (910-2156 MAT1 Mixed Air Sensor)	X	
16	8620-296	Sensor Replacement Kit (910-2084 ST1 Suction Temp Sensor)	X	X
17	8612-064	Dust Sensor Control Board (910-2142)	X	
18	8620-224	3/8" Defrost Sensor Kit (910-2148 LLT1 Liquid Line Temp Sensor)	X	X
19	8301-104	Filter Switch w/Adjustment (910-2141 LH)	X	X
19	8301-104	Blower Fail Switch w/Adjustment (910-2141 LH)	X	X

CONTROL PANEL – S (230/208-60-3 & 220/200-50-3)

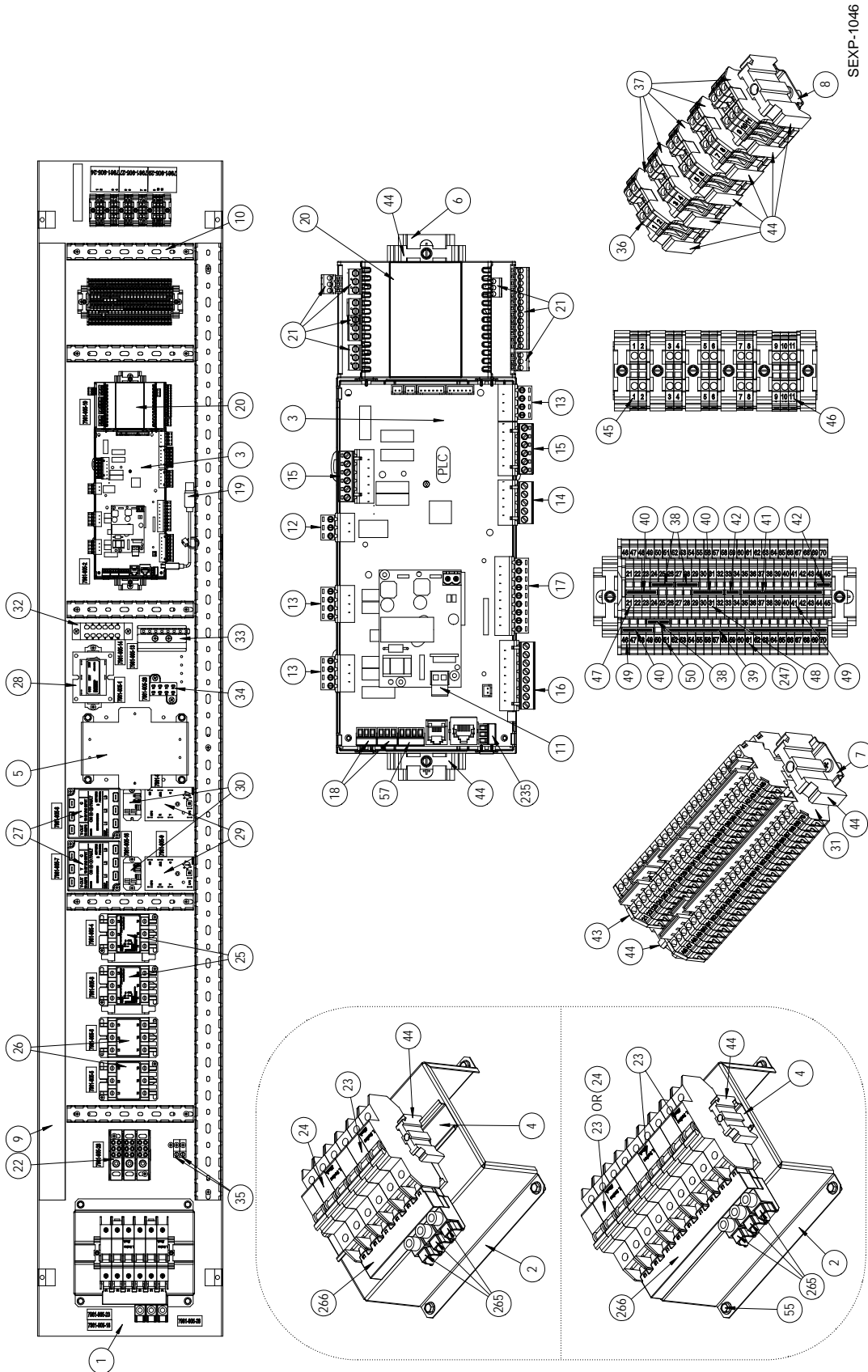

SEXP-1046

CONTROL PANEL – S (230/208-60-3 & 220/200-50-3)

Dwg No.	Part Number	Description	W180BPS0Z W180BPS09	W180BPS18	W180BPS36	W180BES18
1	117-430	Control Sub Panel	X	X	X	X
2	113-933	Riser	X	X	X	X
3	8301-076-002*	UPC3 - MEGA-TEC	X	X	X	X
4	113-858	7-1/4" DIN Rail	X	X	X	X
5	113-860	Rain Channel Control Support	X	X	X	X
6	113-854	13" DIN Rail	X	X	X	X
7	113-857	6-7/16" DIN Rail	X	X	X	X
8	113-853	5" DIN Rail	X	X	X	X
9	8611-258-5700	57" 3-1/4 X 1-1/2 Cable Duct	2	2	2	2
10	8611-229-0712	3-1/4" X 1" Cable Duct X 7-3/4"	5	5	5	5
11	8611-183	2-Pin Circuit Board Connector	X	X	X	X
12	8611-147	3-Pin Circuit Board Connector	X	X	X	X
13	8611-148	4-Pin Circuit Board Connector	3	3	3	3
14	8611-217	5-Pin Circuit Board Connector	X	X	X	X
15	8611-218	6-Pin Circuit Board Connector	2	2	2	2
16	8611-185	8-Pin Circuit Board Connector	X	X	X	X
17	8611-149	9-Pin Circuit Board Connector	X	X	X	X
18	8611-192	3-Pin Circuit Board Connector	2	2	2	2
19	8301-075	USB Micro Cable Female to Male	X	X	X	X
20	8301-081	C.PCOE Expansion PLC Board	X	X	X	X
21	8611-226	Terminal Block Kit for C.PCOE	X	X	X	X
22	8607-070	Power Terminal Block 3-Pole	X	X	X	X
23	8615-110	Circuit Breaker 60A 3-Pole	X	X	3	2
24	8615-109	Circuit Breaker 50A 3-Pole	X	X		
24	8615-107	Circuit Breaker 30A 3-Pole				X
25	8401-037	Contactactor 3-Pole 30 Amp	2	2	2	2
26	8401-041	Contactactor 3-Pole 40 Amp	X	2	2	2
27	S8201-126	3 Phase Line Monitor 50/60 HZ	2	2	2	2
28	8407-065	Transformer 208/240-24 75VA	X	X	X	X
29	S8201-169	Compressor Control Module	2	2	2	2
30	8201-130	Relay, SPDT, Pilot Duty	2	2	2	2
31	8607-058	Double Level Terminal Block	25	25	25	25
32	8607-060	Terminal Block Insul. 12-Position	X	X	X	X
33	8607-061	Terminal Block 16-Position	X	X	X	X
34	8607-072	Terminal Block 8-Position	X	X	X	X
35	8611-006	Terminal	2	2	2	2
36	8611-150	Terminal Block for DIN Rail RS485	11	11	11	11
37	8611-151	Terminal Block End Cap for DIN Rail	5	5	5	5
38	8611-208	Jumper 3-Position	3	3	3	3

Continued on page 20

* Replacement part will have a letter attached to the end of the part number to designate software version (Example: 8301-076-002A). A software upgrade of all PLCs onsite (units and controllers) should accompany any PLC replacement. Latest revisions of software and instructions are available on the Bard website at <http://www.bardhvac.com/software-download/>

Wiring diagram reference listed under **ELECTRIC HEAT COMPONENTS** on page 27.

CONTROL PANEL – S (230/208-60-3 & 220/200-50-3)

Dwg No.	Part Number	Description	W180BFS0Z W180BFS09	W180BFS18	W180BFS36	W180BES18
<i>Continued from page 19</i>						
39	8611-224	Jumper 20-Position	X	X	X	X
40	8611-195	Jumper 4-Position	3	3	3	3
41	8611-203	Jumper 10-Position	X	X	X	X
42	8611-194	Jumper 2-Position	2	2	2	2
43	8611-221	End Cover	X	X	X	X
44	8611-144	End Clamp for DIN Rail	10	10	10	10
45	8607-056	Terminal Designation (1-10)	2	2	2	2
46	8607-055	Terminal Designation (11-20)	2	2	2	2
47	8607-054	Terminal Designation (21-30)	2	2	2	2
48	8607-053	Terminal Designation (31-40)	2	2	2	2
49	8607-059	Terminal Designation (41-50)	2	2	2	2
50	8607-064	Terminal Designation (51-60)	2	2	2	2
57	8611-255	4-Pin Circuit Board Connector Plug	X	X	X	X
235	8611-237	3-Pin Circuit Board Connector	X	X	X	X
247	8607-065	Terminal Designation (61-70)	X	X	X	X
265	8615-088	Jumper Bar Main Lugs	3	3		
265	8615-105	Jumper Bar Main Lugs			3	3
266	8615-090	Two Circuit Bus Bar 3-Pole	X	X		
266	8615-104	Three Circuit Bus Bar 9-Pole			X	X

Wiring diagram reference listed under **ELECTRIC HEAT COMPONENTS** on page 27.

Refer to drawing on page 18

This page intentionally left blank

CONTROL PANEL - T (460-60-3 & 400-50-3), Q (575-60-3) & N (400-60-3)

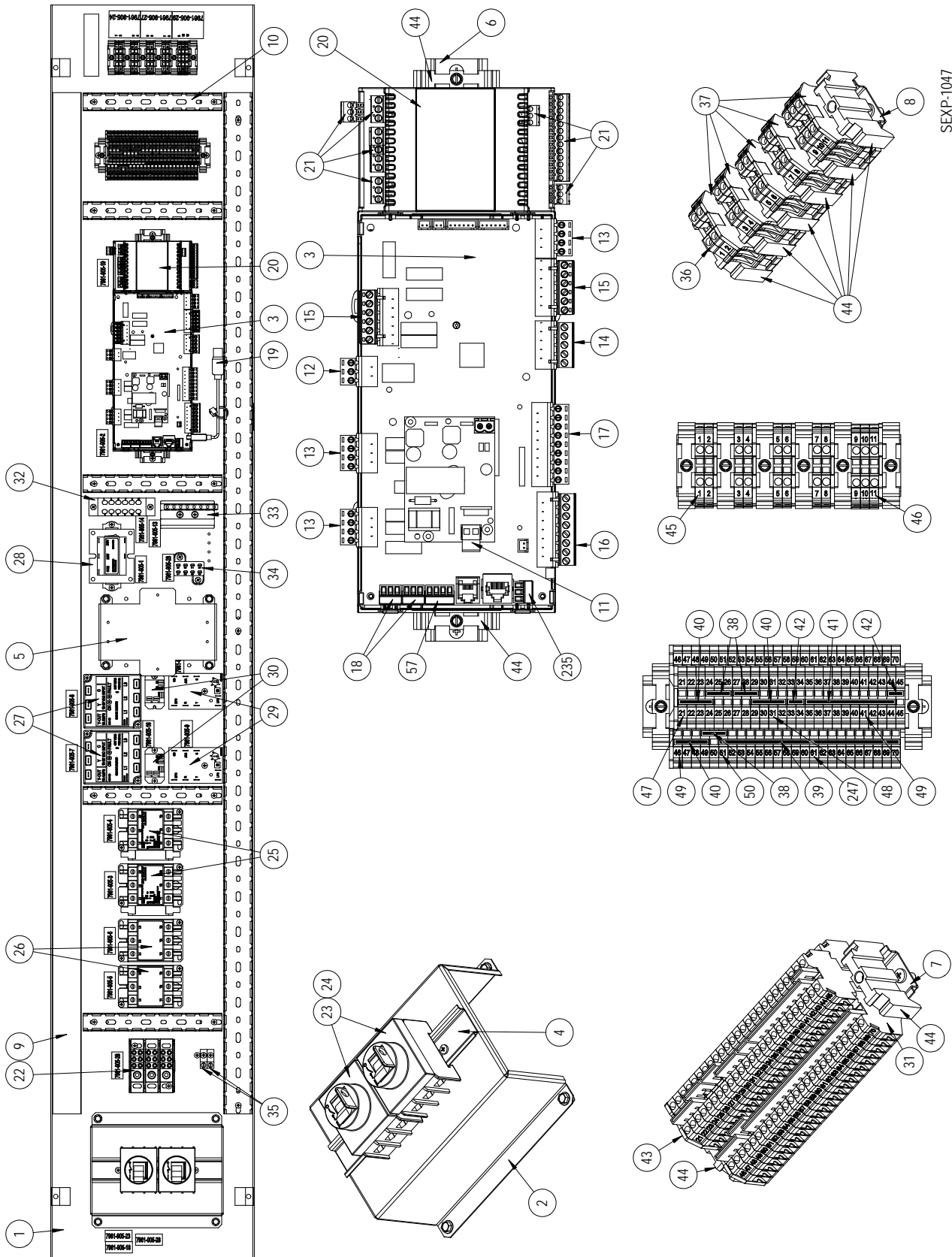

SEXP-1047

This drawing to be used for reference for pages 23 and 24

CONTROL PANEL – T (460-60-3 & 400-50-3), Q (575-60-3) & N (400-60-3)

Dwg No.	Part Number	Description	W180BPT0Z	W180BPT09	W180BPT18	W180BPT36	W180BET18	W180BPQ0Z	W180BPQ09	W180BPQ18	W180BPQ36	W180BEQ18	W180BPN0Z	W180BPN09	W180BPN18	W180BPN36	W180BEN18
1	117-430	Control Sub Panel	X	X	X	X	X	X	X	X	X	X	X	X	X	X	X
2	113-859	Riser	X	X	X	X	X	X	X	X	X	X	X	X	X	X	X
3	8301-076-002*	UPC3 - MEGA-TEC	X	X	X	X	X	X	X	X	X	X	X	X	X	X	X
4	113-858	7-1/4" DIN Rail	X	X	X	X	X	X	X	X	X	X	X	X	X	X	X
5	113-860	Rain Channel Control Support	X	X	X	X	X	X	X	X	X	X	X	X	X	X	X
6	113-854	13" DIN Rail	X	X	X	X	X	X	X	X	X	X	X	X	X	X	X
7	113-857	6-7/16" DIN Rail	X	X	X	X	X	X	X	X	X	X	X	X	X	X	X
8	113-853	5" DIN Rail	X	X	X	X	X	X	X	X	X	X	X	X	X	X	X
9	8611-258-5700	57" 3-1/4 X 1-1/2 Cable Duct	2	2	2	2	2	2	2	2	2	2	2	2	2	2	2
10	8611-229-0712	3-1/4" X 1" Cable Duct X 7-3/4"	5	5	5	5	5	5	5	5	5	5	5	5	5	5	5
11	8611-183	2-Pin Circuit Board Connector	X	X	X	X	X	X	X	X	X	X	X	X	X	X	X
12	8611-147	3-Pin Circuit Board Connector	X	X	X	X	X	X	X	X	X	X	X	X	X	X	X
13	8611-148	4-Pin Circuit Board Connector	3	3	3	3	3	3	3	3	3	3	3	3	3	3	3
14	8611-217	5-Pin Circuit Board Connector	X	X	X	X	X	X	X	X	X	X	X	X	X	X	X
15	8611-218	6-Pin Circuit Board Connector	2	2	2	2	2	2	2	2	2	2	2	2	2	2	2
16	8611-185	8-Pin Circuit Board Connector	X	X	X	X	X	X	X	X	X	X	X	X	X	X	X
17	8611-149	9-Pin Circuit Board Connector	X	X	X	X	X	X	X	X	X	X	X	X	X	X	X
18	8611-192	3-Pin Circuit Board Connector	2	2	2	2	2	2	2	2	2	2	2	2	2	2	2
19	8301-075	USB Micro Cable Female to Male	X	X	X	X	X	X	X	X	X	X	X	X	X	X	X
20	8301-081	C.PCOE Expansion PLC Board	X	X	X	X	X	X	X	X	X	X	X	X	X	X	X
21	8611-226	Terminal Block Kit for C.PCOE	X	X	X	X	X	X	X	X	X	X	X	X	X	X	X
22	8607-070	Power Terminal Block 3-Pole	X	X	X	X	X	X	X	X	X	X	X	X	X	X	X
23	S8615-095	Toggle Disconnect	X	X	X	X	2	X	X	X	X	X	X	X	X	X	2
24	8615-096	Disconnect Cover	X	X	X	X	2	X	X	X	X	X	X	X	X	X	2
25	8401-037	Contacto 3-Pole 30 Amp	2	2	2	2	2	2	2	2	2	2	2	2	2	2	2
26	8401-035	Contacto 3-Pole 25 Amp		X	2	2	2		X	2	2	2		X	2	2	2
27	S8201-126	3 Phase Line Monitor 50/60 HZ	2	2	2	2	2	2	2	2	2	2	2	2	2	2	2
28	8407-072	Transformer 460-24 75VA	X	X	X	X	X	X	X	X	X	X	X	X	X	X	X
29	S8201-169	Compressor Control Module	2	2	2	2	2	2	2	2	2	2	2	2	2	2	2
30	8201-130	Relay, SPDT, Pilot Duty	2	2	2	2	2	2	2	2	2	2	2	2	2	2	2
31	8607-058	Double Level Terminal Block	25	25	25	25	25	25	25	25	25	25	25	25	25	25	25
32	8607-060	Terminal Block Insul. 12-Position	X	X	X	X	X	X	X	X	X	X	X	X	X	X	X
33	8607-061	Terminal Block 16-Position	X	X	X	X	X	X	X	X	X	X	X	X	X	X	X
34	8607-072	Terminal Block 8-Position	X	X	X	X	X	X	X	X	X	X	X	X	X	X	X
35	8611-006	Terminal	2	2	2	2	2	2	2	2	2	2	2	2	2	2	2
36	8611-150	Terminal Block for DIN Rail RS485	11	11	11	11	11	11	11	11	11	11	11	11	11	11	11
37	8611-151	Terminal Block End Cap for DIN Rail	5	5	5	5	5	5	5	5	5	5	5	5	5	5	5
38	8611-208	Jumper 3-Position	3	3	3	3	3	3	3	3	3	3	3	3	3	3	3

Continued on page 24

* Replacement part will have a letter attached to the end of the part number to designate software version (Example: 8301-076-002A). A software upgrade of all PLCs onsite (units and controllers) should accompany any PLC replacement. Latest revisions of software and instructions are available on the Bard website at <http://www.bardhvac.com/software-download/>

Wiring diagram reference listed under **ELECTRIC HEAT COMPONENTS** on page 27.

CONTROL PANEL – T (460-60-3 & 400-50-3), Q (575-60-3) & N (400-60-3)

Dwg No.	Part Number	Description	W180BPT0Z	W180BPT09	W180BPT18	W180BPT36	W180BET18	W180BPQ0Z	W180BPQ09	W180BPQ18	W180BPQ36	W180BEQ18	W180BPN0Z	W180BPN09	W180BPN18	W180BPN36	W180BEN18
<i>Continued from page 23</i>																	
39	8611-224	Jumper 20-Position	X	X	X	X	X	X	X	X	X	X	X	X	X	X	X
40	8611-195	Jumper 4-Position	3	3	3	3	3	3	3	3	3	3	3	3	3	3	3
41	8611-203	Jumper 10-Position	X	X	X	X	X	X	X	X	X	X	X	X	X	X	X
42	8611-194	Jumper 2-Position	2	2	2	2	2	2	2	2	2	2	2	2	2	2	2
43	8611-221	End Cover	X	X	X	X	X	X	X	X	X	X	X	X	X	X	X
44	8611-144	End Clamp for DIN Rail	10	10	10	10	10	10	10	10	10	10	10	10	10	10	10
45	8607-056	Terminal Designation (1-10)	2	2	2	2	2	2	2	2	2	2	2	2	2	2	2
46	8607-055	Terminal Designation (11-20)	2	2	2	2	2	2	2	2	2	2	2	2	2	2	2
47	8607-054	Terminal Designation (21-30)	2	2	2	2	2	2	2	2	2	2	2	2	2	2	2
48	8607-053	Terminal Designation (31-40)	2	2	2	2	2	2	2	2	2	2	2	2	2	2	2
49	8607-059	Terminal Designation (41-50)	2	2	2	2	2	2	2	2	2	2	2	2	2	2	2
50	8607-064	Terminal Designation (51-60)	2	2	2	2	2	2	2	2	2	2	2	2	2	2	2
57	8611-255	4-Pin Circuit Board Connector Plug	X	X	X	X	X	X	X	X	X	X	X	X	X	X	X
235	8611-237	3-Pin Circuit Board Connector	X	X	X	X	X	X	X	X	X	X	X	X	X	X	X
247	8607-065	Terminal Designation (61-70)	X	X	X	X	X	X	X	X	X	X	X	X	X	X	X

Wiring diagram reference listed under **ELECTRIC HEAT COMPONENTS** on page 27.

Refer to drawing on page 22

This page intentionally left blank

ELECTRIC HEAT COMPONENTS

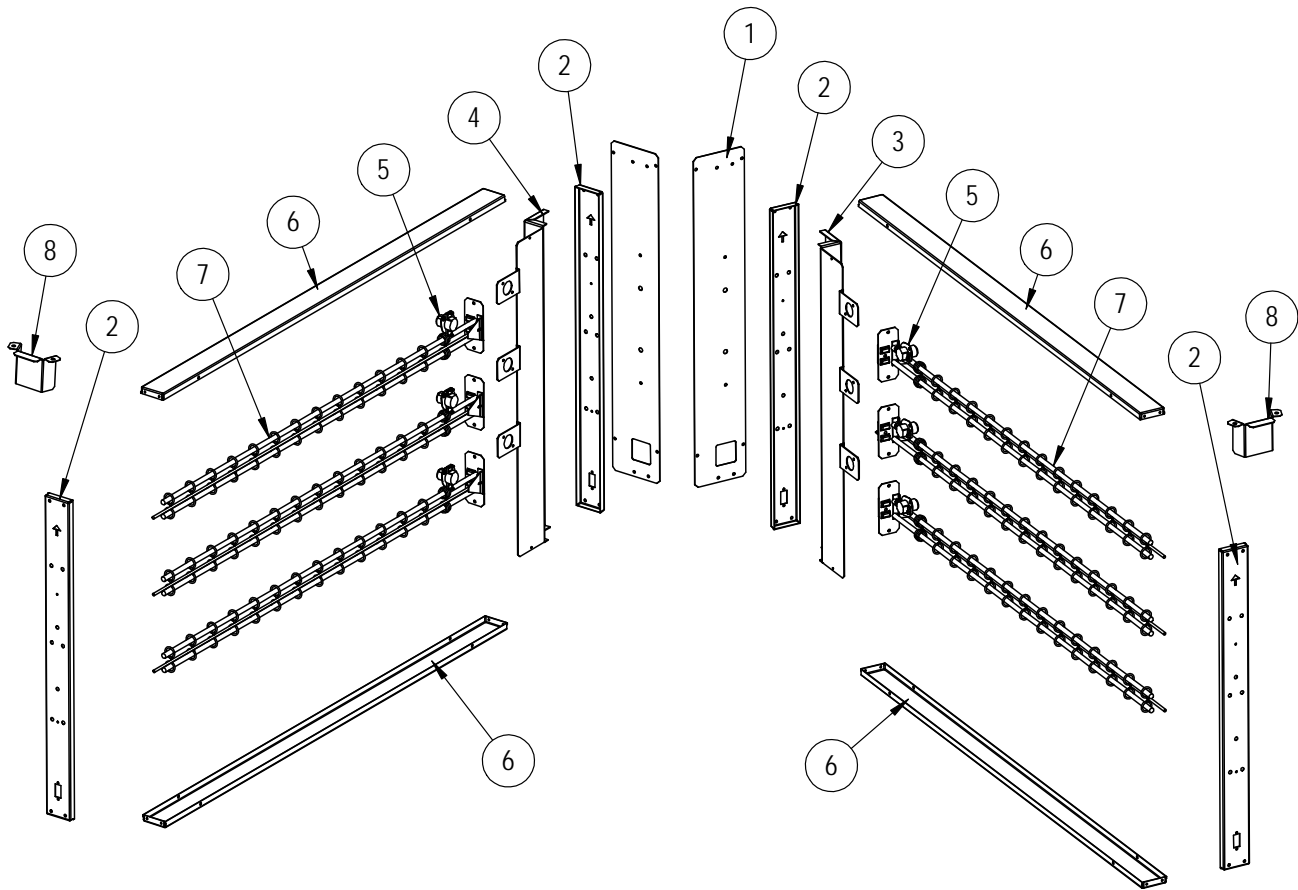
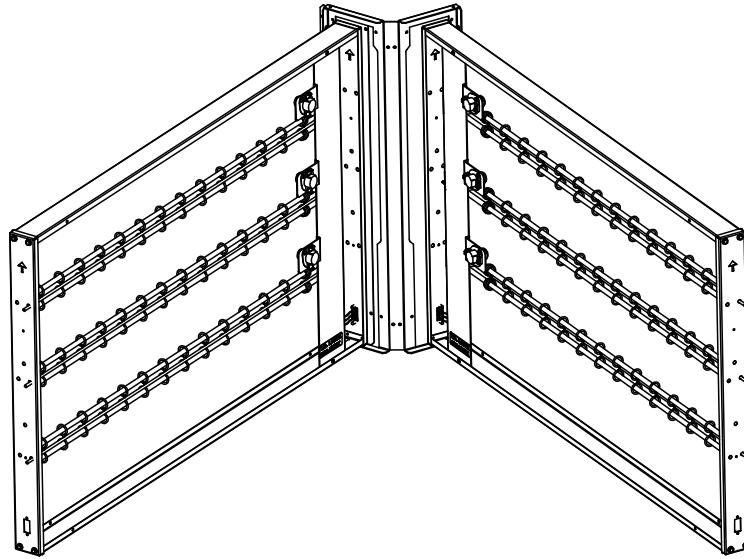

SEXP-1048

ELECTRIC HEAT COMPONENTS

Dwg No.	Part Number	Description	W180BPS0Z	W180BPS09	W180BPS18	W180BPS36	W180BES18	W180BPT0Z	W180BPT09	W180BPT18	W180BPT36	W180BET18	W180BPQ0Z	W180BPQ09	W180BPQ18	W180BPQ36	W180BEQ18	W180BPN0Z	W180BPN09	W180BPN18	W180BPN36	W180BEN18	
1	112-886	Electric Heat Cover Plate		X	2	2	2		X	2	2	2		X	2	2	2		X	2	2	2	
2	113-887	Electric Heat Front/Back		2	4	4	4		2	4	4	4		2	4	4	4		2	4	4	4	
3	113Y888	LH Limit Mount		X	X	X	X		X	X	X	X		X	X	X	X		X	X	X	X	
4	113X888	RH Limit Mount			X	X	X			X	X	X			X	X	X			X	X	X	
5	8402-215	Limit Control		3	6		6																
5	8402-216	Limit Control							3	6		6		3	6		6		3	6		6	
5	8402-217	Limit Control				6					6					6						6	
6	113-884	Electric Heat Top/Bottom		2	4	4	4		2	4	4	4		2	4	4	4		2	4	4	4	
7	8604-151	Heater Element, 3KW, 240/208V, 2-Term		3	6		6																
7	8604-152	Heater Element, 3KW, 460V, 2-Term							3	6		6							3	6		6	
7	8604-153	Heater Element, 3KW, 575V, 2-Term												3	6		6						
7	8604-161	Heater Element, 6KW, 575V, 2-Term									6					6							
7	8604-162	Heater Element, 6KW, 460V, 2-Term										6										6	
7	8604-163	Heater Element, 6KW, 240/208V, 2-Term				6																	
8	113-897	Electric Heat Frame Support		X	2	2	2		X	2	2	2		X	2	2	2		X	2	2	2	
NS	136-1002	Electric Fill Plate (for use when no heater installed)	2	X				2	X				2	X				2	X				
NS	4212-211	Wiring Diagram			X																		
NS	4212-212	Wiring Diagram		X																			
NS	4212-213	Wiring Diagram				X	X																
NS	4212-214	Wiring Diagram	X																				
NS	4212-307	Wiring Diagram								X	X										X	X	
NS	4212-308	Wiring Diagram							X											X			
NS	4212-309	Wiring Diagram						X										X					
NS	4212-310	Wiring Diagram										X											X
NS	4212-704	Wiring Diagram													X	X	X						
NS	4212-706	Wiring Diagram												X									
NS	4212-707	Wiring Diagram											X										

NS – Not Shown

RIGHT AND LEFT INTAKE DAMPER ASSEMBLIES

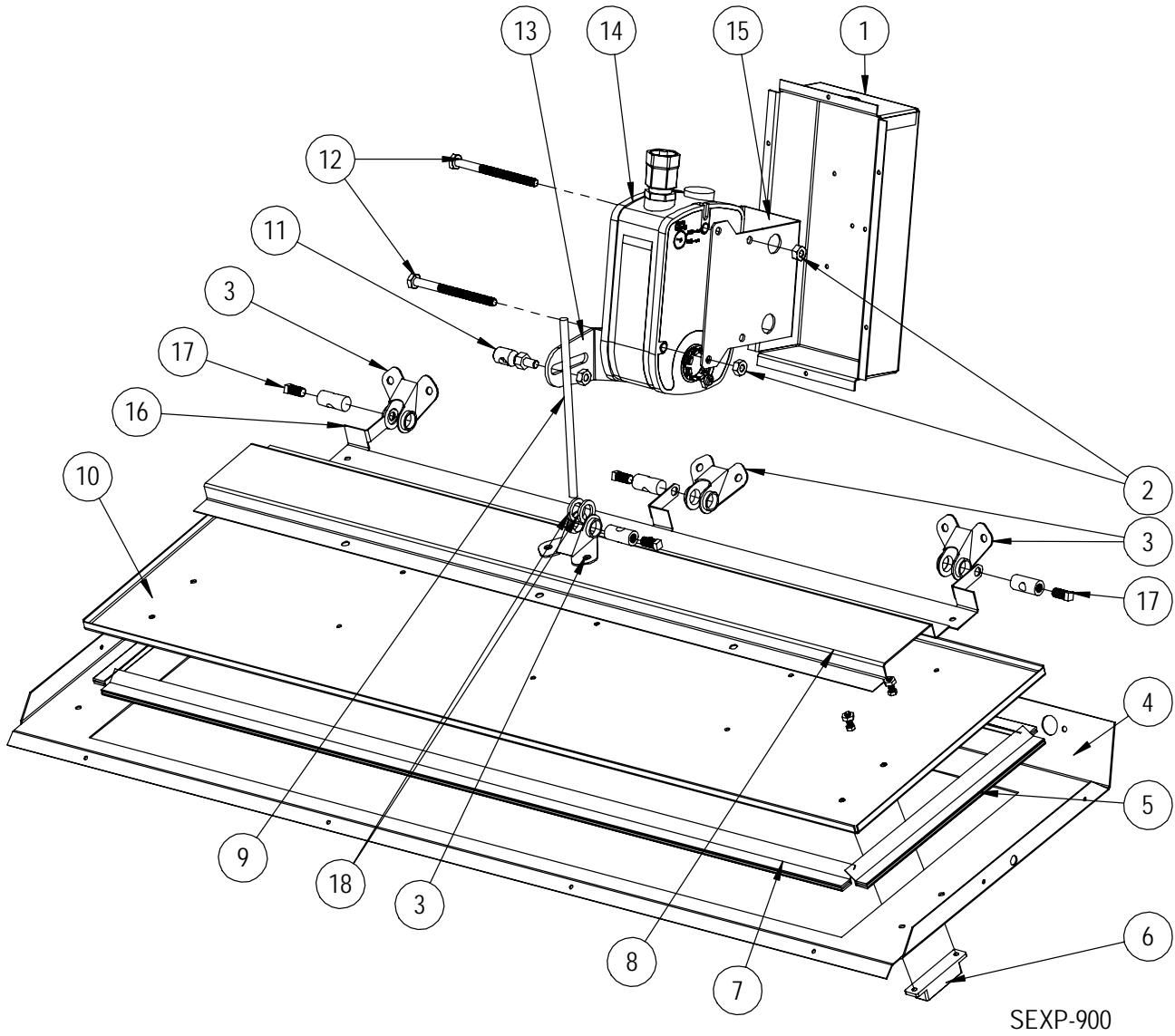

RIGHT AND LEFT INTAKE DAMPER ASSEMBLIES

W180B****E

Dwg. No.	Part Number	Description	
1	135-388	Recessed Actuator Box	2
2	1012-201	1/4"-20 Steel Keps Hex Nut	4
3	8602-040	BKP-24 Butterfly Pivot	8
4	539X447	RH Intake Partition Assembly (includes Blade Seals)	X
4	539Y447	LH Intake Partition Assembly (includes Blade Seals)	X
5	S1921-067-0900	9" Damper Blade Seal	4
6	8406-150	Blade Switch	2
NS	113-743	Blade Switch Bracket	2
7	S1921-067-3707	37-7/16" Damper Blade Seal	4
8	141-529	Intake Blade Support	2
9	8602-042	1/4" X 6" Rod	2
10	539-448	Intake Blade Assembly	2
11	8602-008	Ball Joint	4
12	1012-174	1/4"-20 x 3-1/4" Bolt	4
13	8602-078	Crank Arm	2
14	910-2082	RH Actuator Assembly (includes Crank Arm and wires)	X
14	910-2155	LH Actuator Assembly (includes Crank Arm and wires)	X
14	8602-098	Actuator Only	X
15	113-727	Actuator Mounting Bracket	2
16	113-862	Intake Damper Hinge	2
17	1012-343	1/4"-28 x 1/2" Bolt	6
18	1012-348	1/2" x 3/4" Nylon Flat Washer	4

NS – Not Shown

NOTE: Quantities listed above are totals for both right and left intake damper assemblies.

RIGHT AND LEFT EXHAUST DAMPER ASSEMBLY

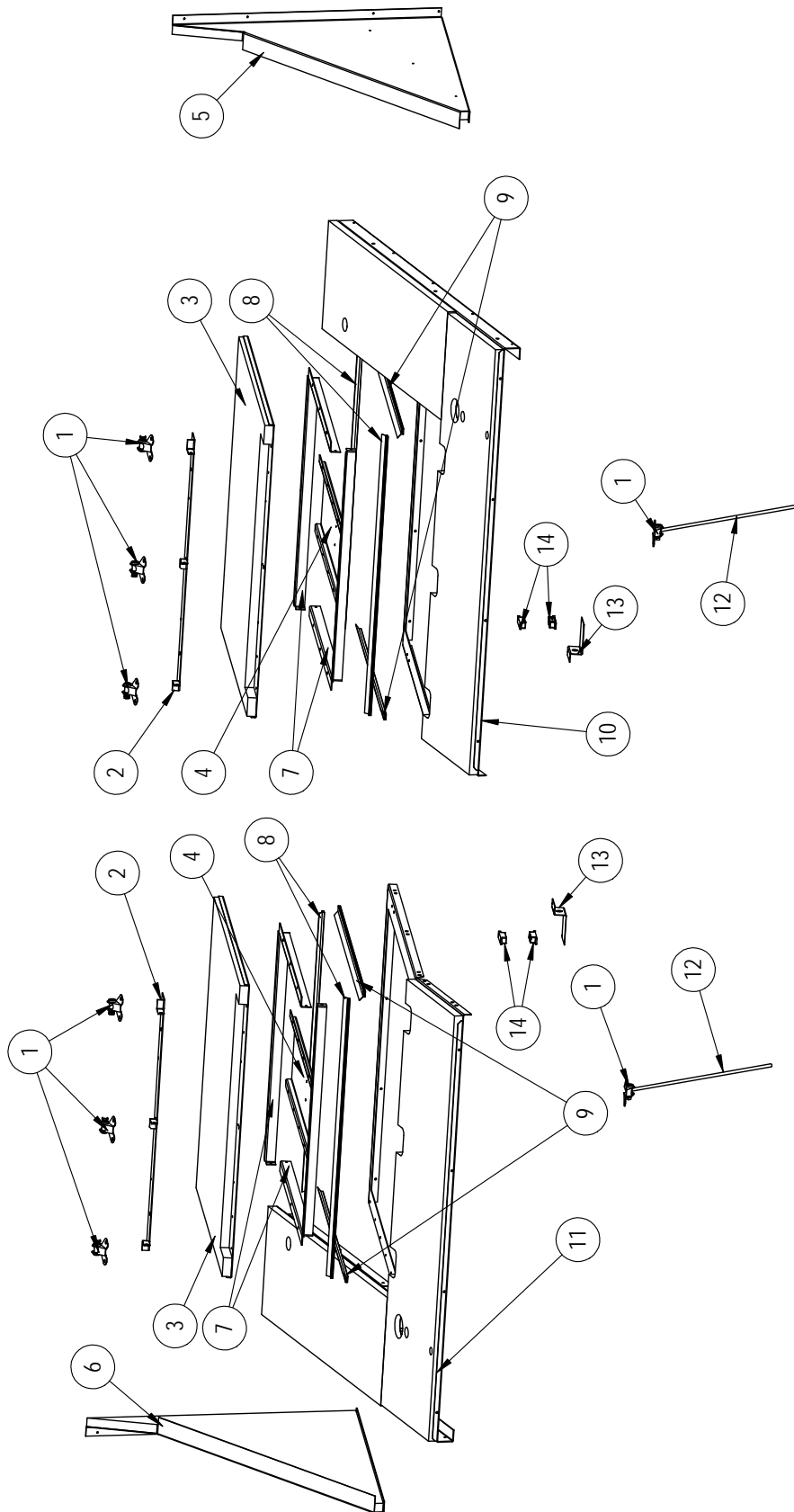

SEXP-1049

RIGHT AND LEFT EXHAUST DAMPER ASSEMBLY

W180B****E

Dwg. No.	Part Number	Description	
1	8602-040	BKP-24 Butterfly Pivot	8
2	113-873	Exhaust Damper Hinge	2
2	113-925 ①	Exhaust Damper Hinge	2
3	539-449	Exhaust Blade Assembly	2
3	539-453 ①	Exhaust Blade Assembly	2
4	141-532	Exhaust Actuator Support	2
4	141-548 ①	Exhaust Actuator Support	2
5	537X998	RH Economizer Deflector	X
5	537X1007 ①	RH Economizer Deflector	X
6	537Y998	LH Economizer Deflector	X
6	537Y1007 ①	LH Economizer Deflector	X
7	113-866	Damper Blade Bracket	4
7	113-923 ①	Damper Blade Bracket	4
8	S1921-067-2403	24-3/16" Damper Blade Seal	4
9	S1921-067-2811 ①	28-11/16" Damper Blade Seal	4
10	521X622	Condenser Partition Assembly RH (includes 537X998 and Damper Blade Seals)	X
10	521X638 ①	Condenser Partition Assembly RH (includes 537X998 and Damper Blade Seals)	X
11	521Y622	Condenser Partition Assembly LH (includes 537Y998 and Damper Blade Seals)	X
11	521Y638 ①	Condenser Partition Assembly LH (includes 537Y998 and Damper Blade Seals)	X
12	8602-097	1/4" X 16-5/8" Rod	2
13	113-871	Blade Switch Bracket	2
13	113-924 ①	Blade Switch Bracket	2
14	8406-150	Blade Switch	2

① Exhaust damper assembly components are manufactured from stainless steel Code "S"

EXHAUST DAMPER ACTUATOR ASSEMBLIES

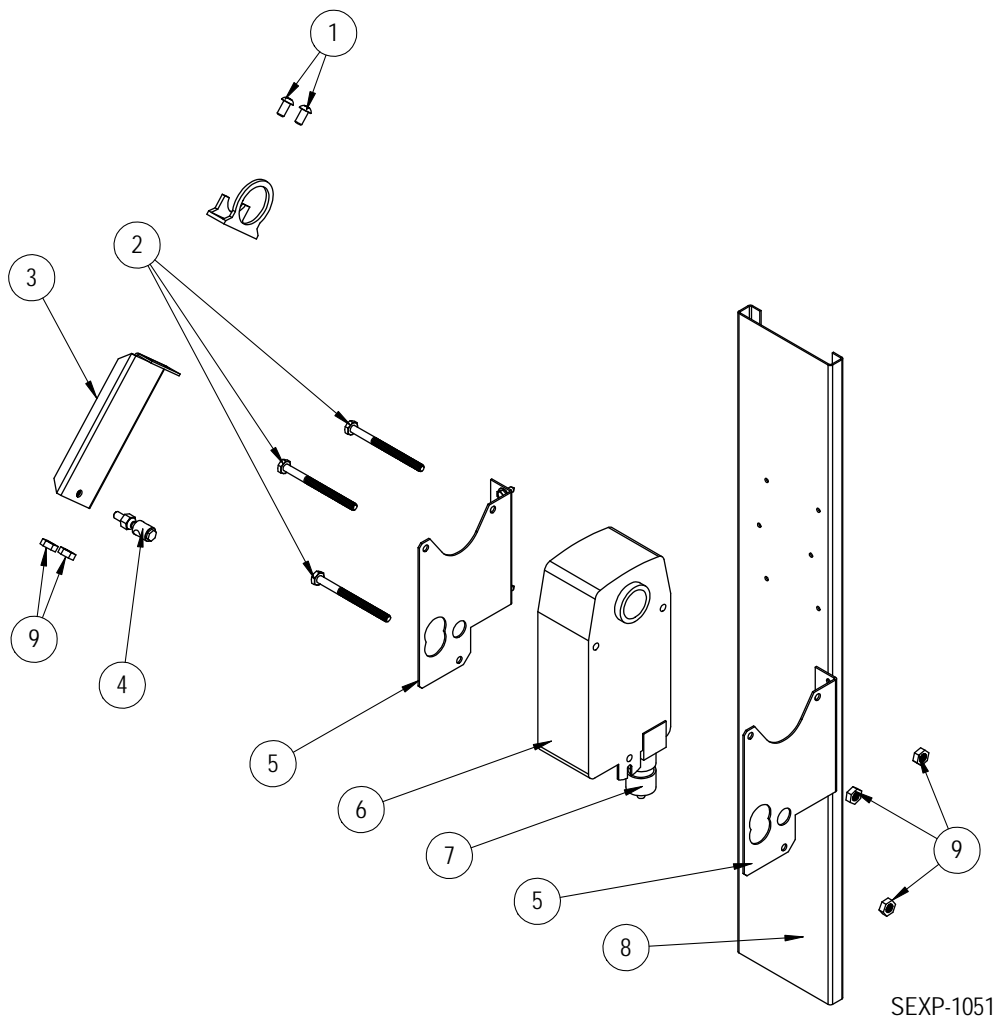

SEXP-1051

W180B****E

Dwg. No.	Part Number	Description	
1	1012-351	1/4"-20 x 1/2" Screw	4
2	1012-174	1/4"-20 x 3-1/4 Bolt	6
2	1012-363 ①	1/4"-20 x 3-1/4 Bolt	6
3	139-399	Actuator Arm	2
3	139-438 ①	Actuator Arm	2
4	8602-008	Ball Joints	2
5	113-728	Actuator Bracket	4
5	113-844 ①	Actuator Bracket	4
6	8602-093	Actuator	2
7	8602-100	Terminal Strip Cover	2
8	141-540	Mounting Plate	2
8	141-549 ①	Mounting Plate	2
9	1012-201	1/4"-20 Steel Keps Hex Nut	10
9	1012-365 ①	1/4"-20 Steel Keps Hex Nut	10

① Exhaust damper assembly components are manufactured from stainless steel Code "S"

NOTE: Quantities listed above are totals for both right and left exhaust damper actuator assemblies.

575V TRANSFORMER ASSEMBLY

910-2151 575V Transformer/Junction Box Assembly

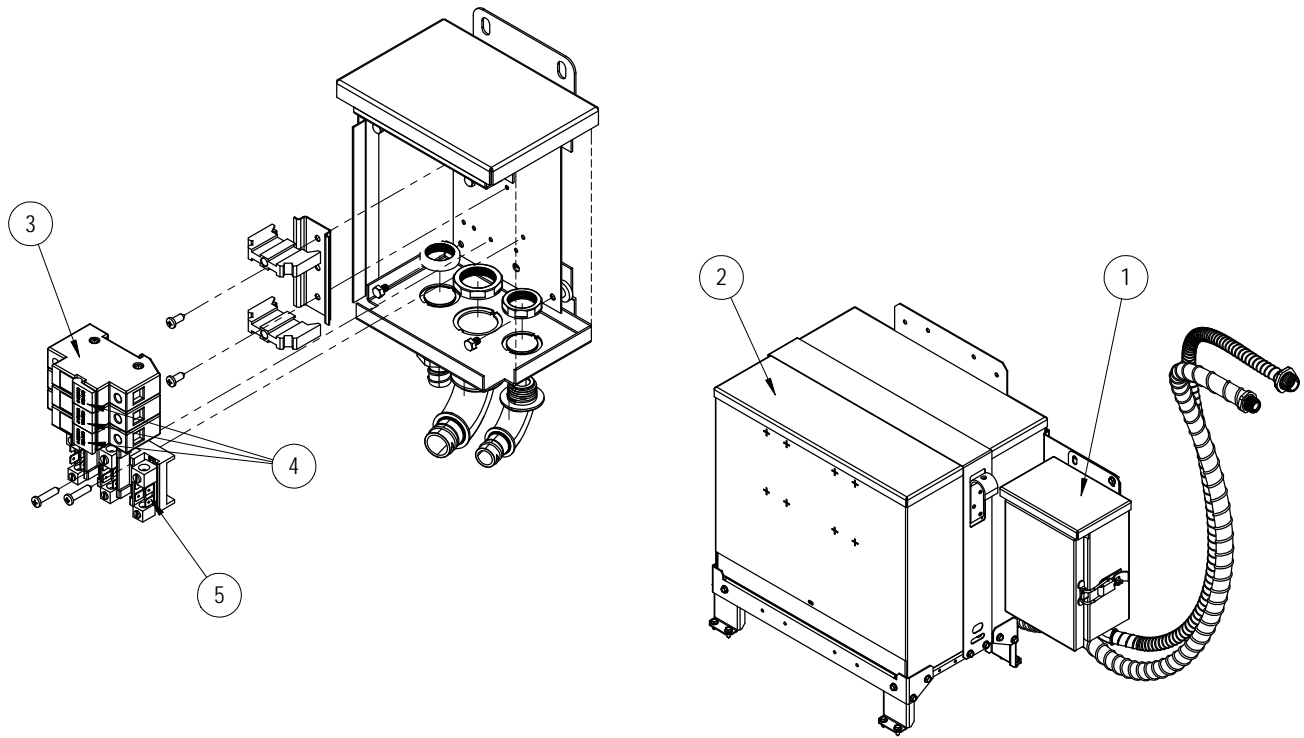

SEXP-1050 A

Dwg No.	Part Number	Description	W180B*Q
1	8615-063	Junction Box w/Hinged Cover	X
2	8407-078	Transformer 3PH 600V/460V 9 kVA	X
3	8614-062	3-Pole Enclosed Fuse Holder	X
4	8614-071	12 Amp Class CC Fuse	3
5	8607-014	3 Terminal Block 240V	X