

---

# REPLACEMENT PARTS MANUAL

---

## Wall Mounted Packaged Air Conditioner

Models:

W30LY-A    W36LY-A  
W30LY-B    W36LY-B  
W30LY-C    W36LY-C  
W30LY-F    W36LYRC  
                  W36LY-F

---

### General Notes

- Revised and/or additional pages may be issued from time to time.
- A complete and current manual consists of pages shown in the following contents section.

### Important

- Contact the installing and/or local Bard distributor for all parts requirements. Make sure to have the complete model and serial number available from the unit rating plates.

### Contents

<u>Description</u>	<u>Page</u>
Cabinet Components	
♦ Exploded View .....	2
♦ Usage List .....	3
♦ Usage List .....	4
Functional Components	
♦ Exploded View .....	6
♦ Usage List .....	7
Control Panel	
♦ Layout View .....	8
♦ Usage List .....	9
Blower Assembly	
♦ Exploded View .....	10
♦ Usage List .....	10



Bard Manufacturing Company, Inc.  
Bryan, Ohio 43506  
www.bardhvac.com

Manual: 2110-1474  
Supersedes: **NEW**  
Date: 6-29-23

# CABINET COMPONENTS

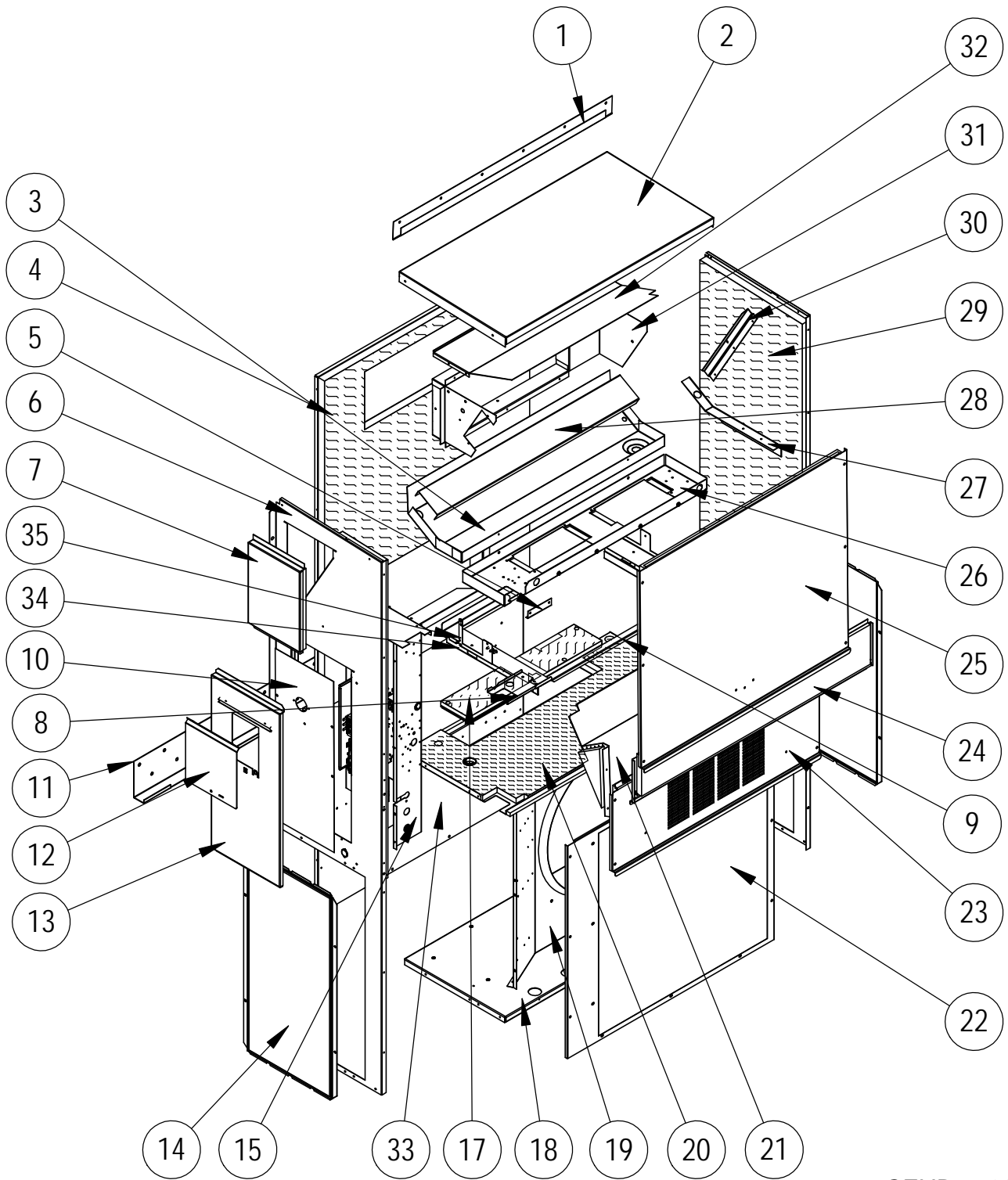

SEXP-1103

This drawing to be used for reference for pages 3 and 4

# CABINET COMPONENTS

Dwg. No.	Part Number	Description	W30LB-A, B	W30LB-C	W30LB-F	W36LB-A, B	W36LB-C, RC	W36LB-F
1	113-149-*BX ①	Top Rain Flashing	X	X	X	X	X	X
1	113-360BX ②	Top Rain Flashing	X	X	X	X	X	X
1	113-149-4BX ③	Top Rain Flashing	X	X	X	X	X	X
2	507-308-*BX ①	Top	X	X	X	X	X	X
2	507-319BX ②	Top	X	X	X	X	X	X
2	507-320BX ③	Top	X	X	X	X	X	X
3	123-130BX	Drain Pan	X	X	X	X	X	X
3	123-143BX ②③	Drain Pan	X	X	X	X	X	X
4	509-451BX	Upper Back	X	X	X	X	X	X
4	509-455BX ②	Upper Back	X	X	X	X	X	X
4	509-453BX ③	Upper Back	X	X	X	X	X	X
5	105-1302BX	Grommet Retainer	X	X	X	X	X	X
6	501-935-*BX ①	Right Side	X	X	X	X	X	X
6	501-998BX ②	Right Side	X	X	X	X	X	X
6	501-943BX ③	Right Side	X	X	X	X	X	X
7	543-175-*BX ①	Right Side Cover Plate (Outer)	X	X	X	X	X	X
7	543-185BX ②	Right Side Cover Plate (Outer)	X	X	X	X	X	X
7	543-184BX ③	Right Side Cover Plate (Outer)	X	X	X	X	X	X
8	137Y1101BX	Filter Fill Plate	X	X	X	X	X	X
9	131-194BX	Filter Partition Bracket	X	X	X	X	X	X
10	132-104BX	Control Panel Cover (Inner)	X			X		
10	132-172BX	Control Panel Cover (Inner)		X	X		X	X
11	113-140BX	Bottom Mounting Bracket	X	X	X	X	X	X
12	153-218BX ①	Disconnect Access Door	X	X	X	X	X	X
12	153-405BX ②	Disconnect Access Door	X	X	X	X	X	X
12	153-387BX ③	Disconnect Access Door	X	X	X	X	X	X
13	533-228BX ①	Control Panel Cover (Outer)	X	X	X	X	X	X
13	533-235BX ②	Control Panel Cover (Outer)	X	X	X	X	X	X
13	533-236BX ③	Control Panel Cover (Outer)	X	X	X	X	X	X
14	118-124-*BX ①	Side Grille	2	2	2	2	2	2
14	118-140BX ②	Side Grille	2	2	2	2	2	2
14	118-141BX ③	Side Grille	2	2	2	2	2	2
15	Control Panel Assembly	See <b>Control Panel</b> on pages 8 & 9	X	X	X	X	X	X
17	536-498BX	Cond. Partition Block Off Plate	X	X	X	X	X	X
17	536-877BX ②	Cond. Partition Block Off Plate	X	X	X	X	X	X
18	127-472BX	Lower Base	X	X	X	X	X	X
18	127-533BX ②	Lower Base	X	X	X	X	X	X
19	125-081BX	Fan Shroud	X	X	X	X	X	X
19	125-083BX ②	Fan Shroud	X	X	X	X	X	X
20	521Y527BX	Condenser Partition	X	X	X	X	X	X
20	521*-561BX ②	Condenser Partition	X	X	X	X	X	X
21	FAD-NE3	Fresh Air Damper Assembly	X	X	X	X	X	X
22	118-104-*BX ①	Condenser Grille	X	X	X	X	X	X
22	118-109BX ②	Condenser Grille	X	X	X	X	X	X
22	118-147BX ③	Condenser Grille	X	X	X	X	X	X

*Continued on page 4*

① Exterior cabinet parts are manufactured with various paint color options. To ensure the proper paint color is received, include the complete model and serial number of the unit for which cabinet parts are being ordered.

② Exterior cabinet parts are manufactured from stainless steel Code "S"

③ Exterior cabinet parts are manufactured from aluminum Code "A"

# CABINET COMPONENTS

Dwg. No.	Part Number	Description	W30LB-A, B	W30LB-C	W30LB-F	W36LB-A, B	W36LB-C, RC	W36LB-F
<i>Continued from page 3</i>								
23	553-523-*BX ①	Vent Option Door	X	X	X	X	X	X
23	553-549BX ②	Vent Option Door	X	X	X	X	X	X
23	553-550BX ③	Vent Option Door	X	X	X	X	X	X
24	553-524-*BX ①	Filter Door	X	X	X	X	X	X
24	553-553BX ②	Filter Door	X	X	X	X	X	X
24	553-554BX ③	Filter Door	X	X	X	X	X	X
25	514-241-*BX ①	Upper Front	X	X	X	X	X	X
25	514-238BX ②	Upper Front	X	X	X	X	X	X
25	514-239BX ③	Upper Front	X	X	X	X	X	X
26	121Y467BX	Blower Partition	X	X	X	X	X	X
27	105Y850BX	Side Support	X	X	X	X	X	X
28	137-685BX	Bottom Evaporator Fill	X	X	X	X	X	X
29	501-936-*BX ①	Left Side	X	X	X	X	X	X
29	501-999BX ②	Left Side	X	X	X	X	X	X
29	501-946BX ③	Left Side	X	X	X	X	X	X
30	147-044BX	Evaporator Support	X	X	X	X	X	X
31	111Y030BX	Outlet Air Frame Assembly	X	X	X	X	X	X
32	135Y123BX	Heat Shield	X	X	X	X	X	X
33	109-450BX	Lower Back	X	X	X	X	X	X
33	109-454BX ②	Lower Back	X	X	X	X	X	X
33	109-452BX ③	Lower Back	X	X	X	X	X	X
34	131-190BX	Filter Tray Angle	X	X	X	X	X	X
35	131Y189BX	Filter Partition	X	X	X	X	X	X
NS	135-329BX	Air Baffle	X	X	X	X	X	X

- ① Exterior cabinet parts are manufactured with various paint color options. To ensure the proper paint color is received, include the complete model and serial number of the unit for which cabinet parts are being ordered.
- ② Exterior cabinet parts are manufactured from stainless steel Code "S"
- ③ Exterior cabinet parts are manufactured from aluminum Code "A"

**Refer to drawing on page 2**

*This page intentionally left blank*

# FUNCTIONAL COMPONENTS

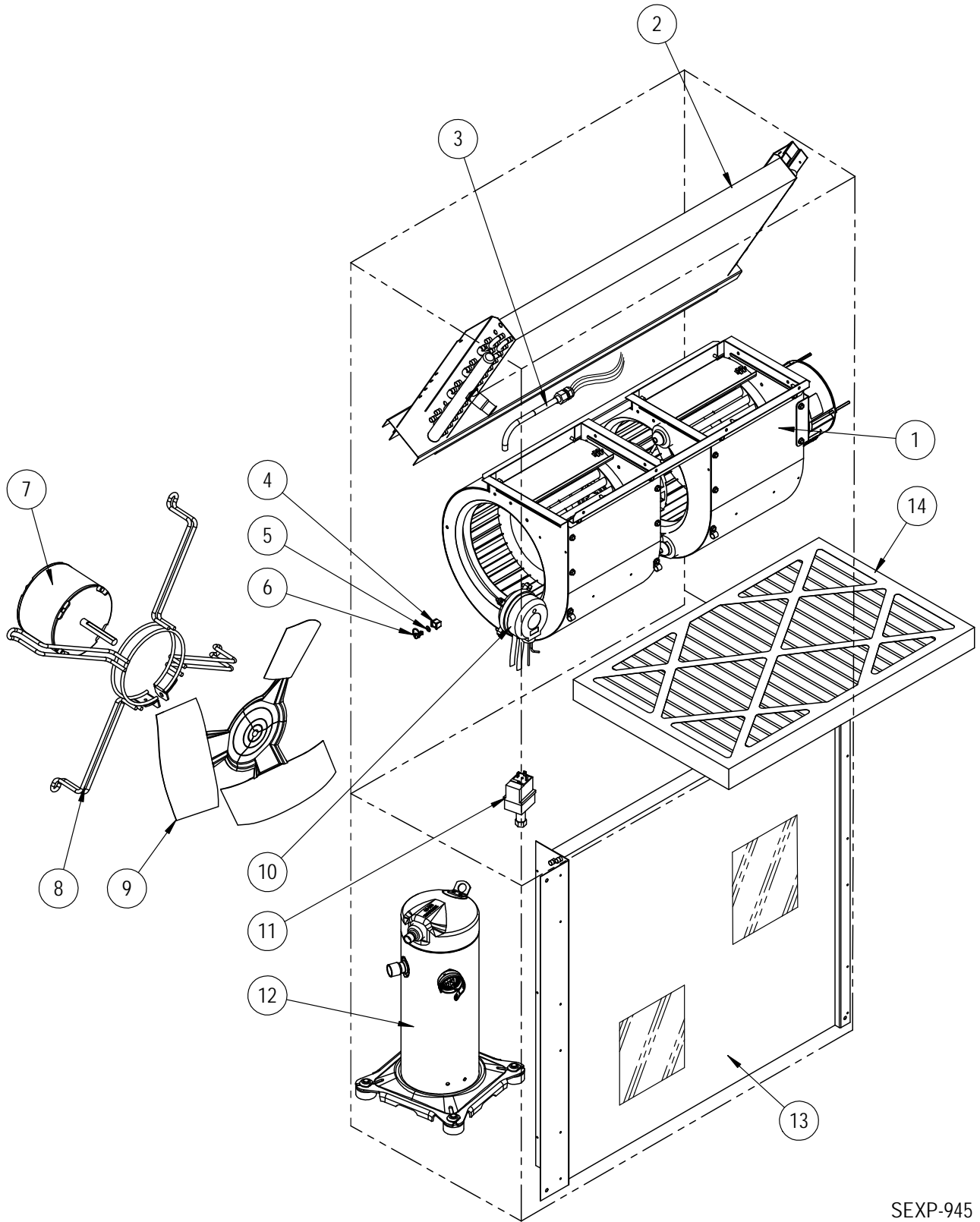

SEXP-945

# FUNCTIONAL COMPONENTS

Dwg No.	Part Number	Description	W30LB-A	W30LB-B	W30LB-C	W30LB-F	W36LB-A	W36LB-B	W36LB-C	W36LBRC	W36AB-F
1	900-364-001BX	Blower Assembly	X	X		X					
1	900-365-001BX	Blower Assembly			X						
1	900-364-002BX	Blower Assembly					X	X		X	X
1	900-365-002BX	Blower Assembly							X		
2	917-0355BX	Evaporator Coil w/Distributor Assy.	X	X	X	X					
2	917-0356BX	Evaporator Coil – Coated w/Distributor Assy.	X	X	X	X					
2	917-0357BX	Evaporator Coil w/Distributor Assy.					X	X	X	X	X
2	917-0358BX	Evaporator Coil – Coated w/Distributor Assy.					X	X	X	X	X
3	800-0456BX	Distributor Assembly					X	X	X	X	X
3	800-0479BX	Distributor Assembly	X	X	X	X					
4	1171-023	1/4" Receptacle	X	X	X	X	X	X	X	X	X
5	1171-024	1/4" Turn Retainer	X	X	X	X	X	X	X	X	X
6	1171-022	1/4" Turn Fastener	X	X	X	X	X	X	X	X	X
7	8103-029BX	Condenser Motor	X	X		X	X				X
7	8103-030BX	Condenser Motor			X				X	X	
8	8200-001BX	Fan Motor Mount	X	X	X	X	X	X	X	X	X
8	8200-050BX ①	Stainless Steel Fan Motor Mount	X	X	X	X	X	X	X	X	X
9	5151-045BX	Fan Blade	X	X	X	X	X	X	X	X	X
9	5151C045BX ①	Coated Fan Blade	X	X	X	X	X	X	X	X	X
10	CMA-31	Dirty Filter Switch Kit	X	X	X	X	X	X	X	X	X
11	CMA-41	Low Ambient Control (Screw On) ②	X	X	X	X	X	X	X	X	X
12	8000-277BX	Compressor	X								
12	8000-365BX	Compressor		X							
12	8000-366BX	Compressor			X	X					
12	8000-278BX	Compressor					X				
12	8000-283BX	Compressor						X			
12	8000-342BX	Compressor							X	X	X
13	5051-203BX	Condenser Coil	X	X	X	X					
13	5054-203BX	Condenser Coil – Coated	X	X	X	X					
13	5051-202BX	Condenser Coil					X	X	X	X	X
13	5054-202BX	Condenser Coil – Coated					X	X	X	X	X
14	7004-019	Air Filter 1" Throw-Away (16x30x1)	X	X	X	X	X	X	X	X	X
14	7003-031	Air Filter 1" Washable ② (16x30x1)	X	X	X	X	X	X	X	X	X
14	7004-026	Air Filter 2" Pleated ② (16x30x2)	X	X	X	X	X	X	X	X	X
14	7004-048	Air Filter 2" Pleated – MERV 11 ② (16x30x2)	X	X	X	X	X	X	X	X	X
14	7004-062	Air Filter 2" Pleated – MERV 13 ② (16x30x2)	X	X	X	X	X	X	X	X	X
NS	8406-142BX	High Pressure Switch (Screw On)	X	X	X	X	X	X	X	X	X
NS	8406-140BX	Low Pressure Switch (Screw On)	X	X	X	X	X	X	X	X	X
NS	5201-021BX	Filter Drier	X	X	X	X	X	X	X	X	X
NS	5451-024	Tubing Isolation Grommet	X	X	X	X	X	X	X	X	X
NS	6031-009	Coremax Valve Core	X	X	X	X	X	X	X	X	X
NS	1171-028	Filter Door Clip	X	X	X	X	X	X	X	X	X
NS	1171-057	Filter Door Screw	X	X	X	X	X	X	X	X	X
NS	1171-027	Filter Door Screw Retainer	X	X	X	X	X	X	X	X	X
NS	CMC-29	Freeze Thermostat Kit	X	X	X	X	X	X	X	X	X
NS	910-2189BX	460V Transformer Assembly								X	

NS – Not Shown

① – Used with stainless steel cabinet option

② – Optional on these models

# CONTROL PANEL

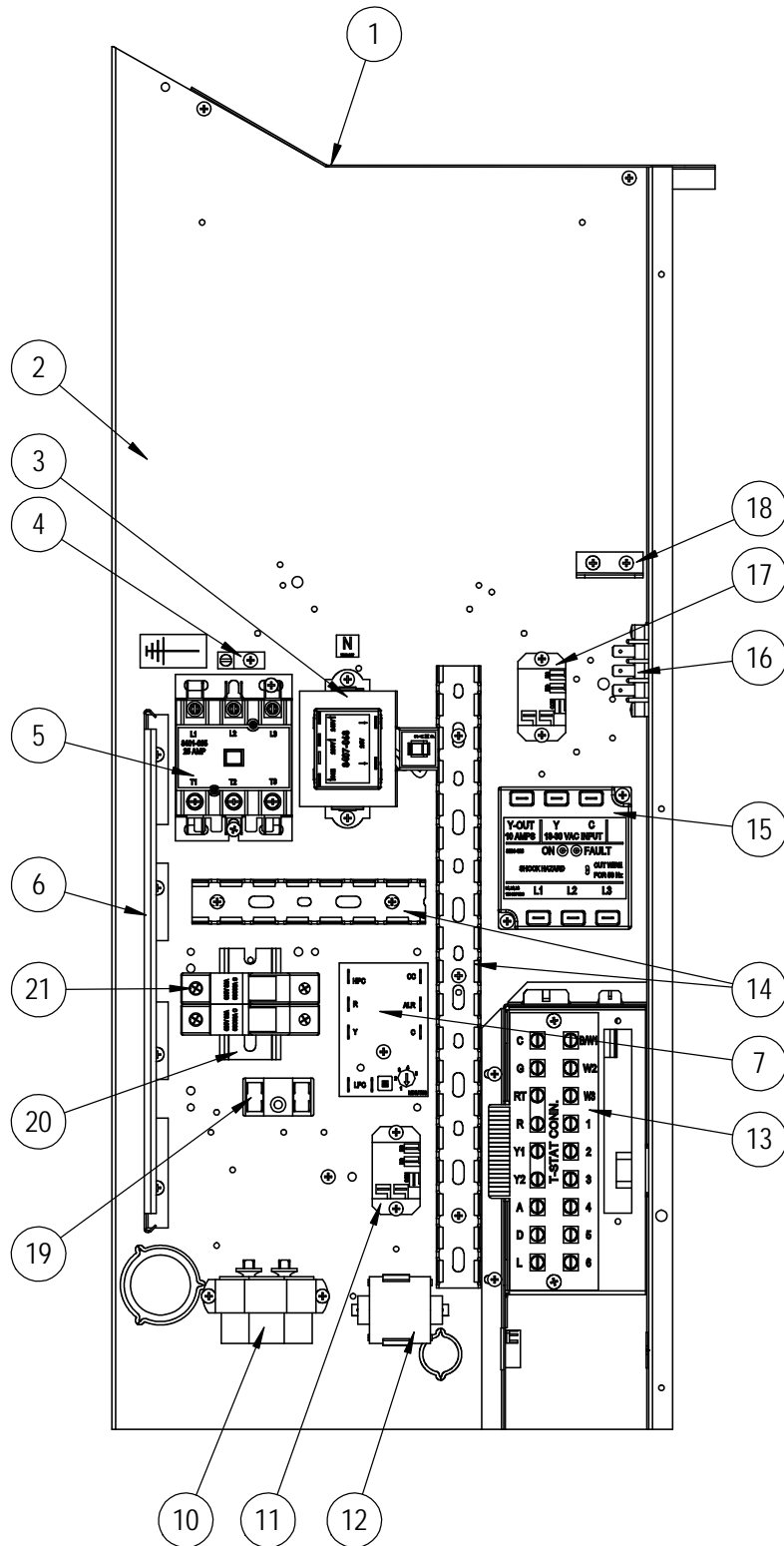

SXP-947 A



# CONTROL PANEL

Dwg No.	Part Number	Description	W30LB-A	W30LB-B	W30LB-C	W30LB-F	W36LB-A	W36LB-B	W36LB-C	W36LBRC	W36LB-F
1	117Y137BX	Control Panel Top	X	X	X	X	X	X	X	X	X
2	117Y407BX	Control Panel	X	X	X	X	X	X	X	X	X
3	8407-068BX	Transformer	X	X		X	X	X			X
3	8407-069BX	Transformer			X				X	X	
4	8611-006	Ground Terminal	X	X	X	X	X	X	X	X	X
5	8401-033BX	Compressor Contactor	X				X				
5	8401-035BX	Compressor Contactor		X	X	X		X	X	X	X
6	135-122BX	Wire Shield	X	X	X	X	X	X	X	X	X
7	8201-171BX	Compressor Control Module	X	X	X	X	X	X	X	X	X
9	8607-017BX	Terminal Block (Optional)	X	X	X	X	X	X	X	X	X
10	8552-052BX	Compressor Capacitor	X				X				
10	8552-002BX	Outdoor Motor Capacitor		X	X	X		X	X	X	X
11	8201-062BX	Alarm Relay (Optional)	X	X	X	X	X	X	X	X	X
12	8551-004BX	Start Device (PTCR) (Optional)	X	X	X	X	X	X	X	X	X
13	8607-062BX	Low Voltage Terminal Strip	X	X	X	X	X	X	X	X	X
14	8611-140-1400	Cable Duct – 14" Piece	X	X	X	X	X	X	X	X	X
14	8611-140-0500	Cable Duct – 5" Piece	X	X	X	X	X	X	X	X	X
15	8201-174BX	Phase Monitor		X	X	X		X	X	X	X
16	8607-042	Blower Speed Terminal	X	X	X	X	X	X	X	X	X
17	8201-130BX	Blower Control Relay	X	X	X	X	X	X	X	X	X
18	141-595BX	Plug Support Bracket	X	X	X	X	X	X	X	X	X
19	8607-017BX	Terminal Block								X	
20	8611-210BX	DIN Rail								X	
21	8614-058	Fuse Block								X	
21	8614-047	3.2A Fuse								2	
NS	8615-038BX	Circuit Breaker 35A 2 Pole (Opt.) ①	X				X				
NS	8615-054BX	Circuit Breaker 20A 3 Pole (Opt.) ①		X							
NS	8615-052BX	Circuit Breaker 30A 3 Pole (Opt.) ①						X			
NS	8615-067BX	Toggle Disconnect (Optional) ①			X	X			X	X	X
NS	8607-013BX	Terminal Block 2 Pole				X					X
NS	113-601BX	Terminal Block Bracket				X					X
NS	4213-124	Wiring Diagram	X				X				
NS	4213-224	Wiring Diagram		X				X			
NS	4213-324	Wiring Diagram			X				X		
NS	4213-327	Wiring Diagram								X	
NS	4213-624	Wiring Diagram				X					X
NS	3000-1598BX	Blower Power Plug	X	X	X	X	X	X	X	X	X
NS	3000-1599BX	Blower Speed Plug	X	X	X	X	X	X	X	X	X
NS	3000-1524BX	Vent Jumper Plug	X	X	X	X	X	X	X	X	X
NS	3000-1224BX	Compressor Plug/Harness	X				X				
NS	3000-1231BX	Compressor Plug/Harness		X	X	X		X	X	X	X
NS	3003-126BX	Control Panel Harness	X				X				
NS	3003-127BX	Control Panel Harness		X	X			X	X	X	
NS	3003-128BX	Control Panel Harness				X					X
NS	3000-1608BX	Low Voltage Terminal Block Harness	X	X	X	X	X	X	X	X	X
NS	910-2048BX	Complete Low Voltage Box Assembly (Sheet Metal, LVTS & Wire Harness)	X	X	X	X	X	X	X	X	X

NS = Not Shown

① Circuit breakers listed are for units without electric heat, "OZ" models. See heater replacement parts manual for units with electric heat.

# BLOWER ASSEMBLY

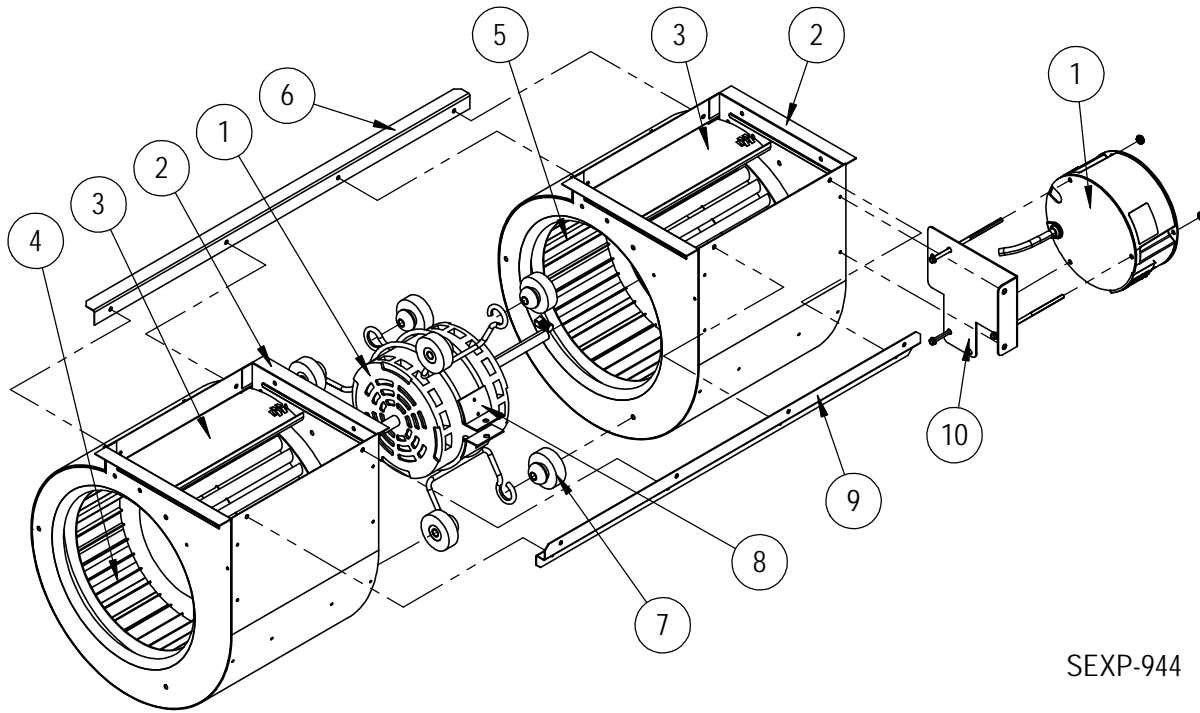

SEXP-944

Dwg No.	Part Number	Description	900-364-001BX	900-364-002BX	900-365-001BX	900-365-002BX
1	8106-068-0150BX	Blower Motor & Control (230/208V)	X			
1	8106-068-0152BX	Blower Motor & Control (230/208V)		X		
1	8106-069-0151BX	Blower Motor & Control (460V)			X	
1	8106-069-0153BX	Blower Motor & Control (460V)				X
1	C8106-068-0150	Programmed Control Only (230/208V)	0			
1	C8106-068-0152	Programmed Control Only (230/208V)		0		
1	C8106-069-0151	Programmed Control Only (460V)			0	
1	C8106-069-0153	Programmed Control Only (460V)				0
2	151-111BX	Housing	2	2	2	2
3	144-174BX	Diffuser	2	2	2	2
4	5152-090BX	Wheel CW	X	X	X	X
5	5152-091BX	Wheel CCW	X	X	X	X
6	105-870BX	Back Brace	X	X	X	X
7	5451-011	Grommets	6	6	6	6
8	8200-031BX	Motor Mount	X	X	X	X
9	103-401BX	Front Brace	X	X	X	X
10	113-761BX	Motor Control Bracket	X	X	X	X

X – Standard Component  
 O – Optional Component