REPLACEMENT PARTS MANUAL

QTEC SERIES PACKAGED AIR CONDITIONER

Models:

Q24A2 **Q30A2**
Q36A2 **Q42A2**
Q48A2 **Q60A2**

General Notes

- Revised and/or additional pages may be issued from time to time.
- A complete and current manual consists of pages shown in the following contents section.

Contents

Description	Page
Cabinet Components	
♦ Exploded View	2
♦ Usage List	3
♦ Usage List	4
♦ Usage List	5
♦ Usage List	6
♦ Blank Page	7
Functional Components	
♦ Exploded View	8
♦ Usage List	9
♦ Usage List	10
♦ Usage List	11
♦ Blank Page	12
Upper Control Panel Components	
♦ Exploded View	13
♦ Usage List	14
♦ Usage List	15
♦ Usage List	16
♦ Usage List	17
♦ Usage List	18
♦ Usage List	19
Lower Control Panel Components	
♦ Exploded View	20
♦ Usage List	21
Blower Assembly Components	
♦ Exploded View	22
♦ Usage List	23
Optional Climate Control Components	
♦ Exploded View	24
♦ Usage List	25
Wall Sleeve Cabinet Components	
♦ Exploded View	26
♦ Usage List	27



Bard Manufacturing Company, Inc.
Bryan, Ohio 43506
Since 1914...Moving ahead, just as planned.

Manual: 2110-1506
Supersedes: **NEW**
File: Tab 14
Date: 09-10-13

CABINET COMPONENTS

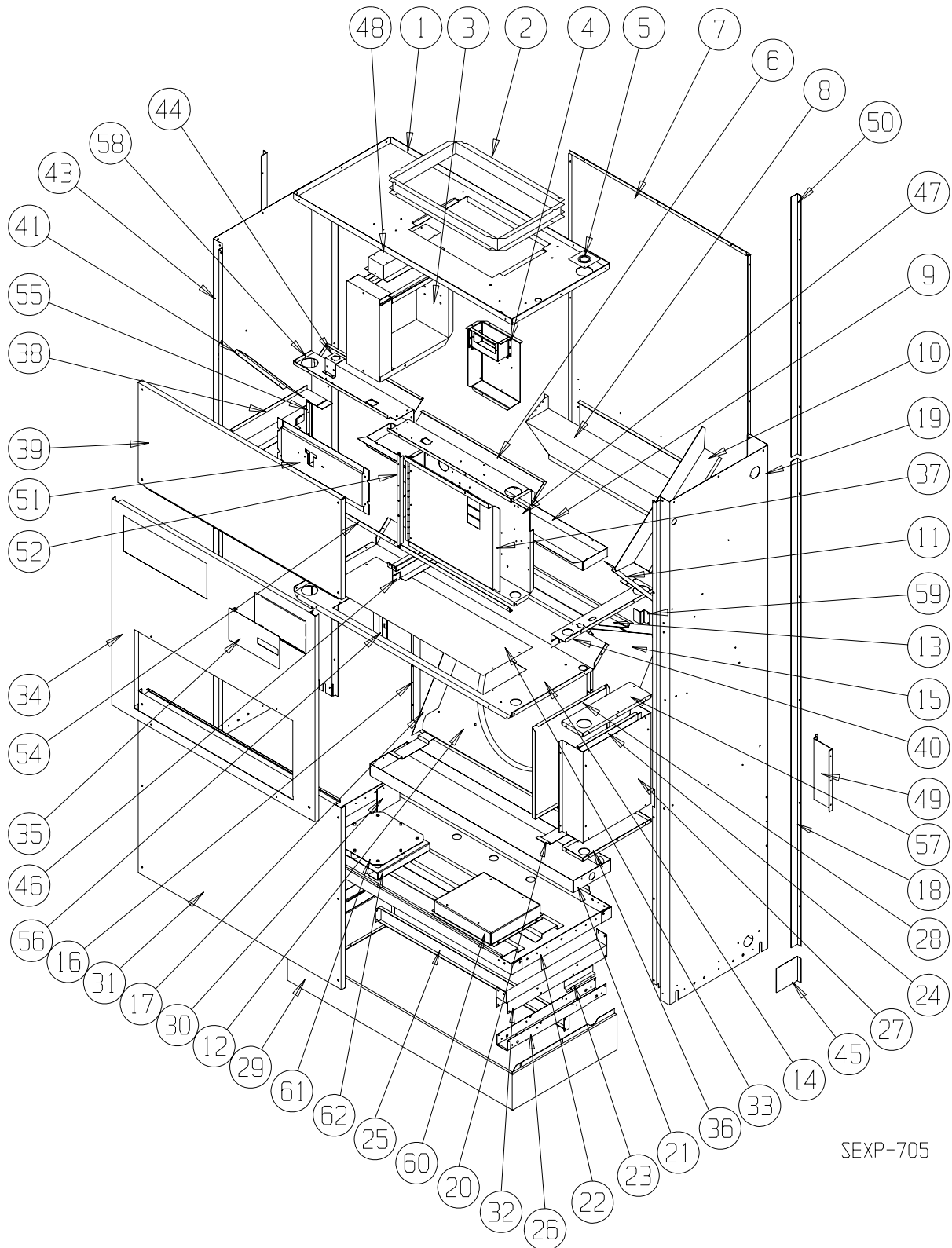

SEXP-705

This Exploded View is referenced in Tables on Page 3, 4, 5 & 6

CABINET COMPONENTS

Drawing No.	Part No.	Description	Q24A2-A, -B	Q24A2-C	Q30A2-A, -B	Q30A2-C	Q36A2-A, -B	Q36A2-C	Q42A2-A, -B	Q42A2-C
1	506-225	Top Assembly	X	X	X	X	X	X	X	X
2	110-044	Outlet Duct Flange	2	2	2	2	2	2	2	2
3	See Page 13	Heater Package Assembly (Optional)	X	X	X	X	X	X	X	X
4	117-283	Low Voltage Box Assembly (Optional)	X	X	X	X	X	X	X	X
5	136-359	T.K.O. Plate	X	X	X	X	X	X	X	X
6	534-191	Evaporator Coil Shield - Right	X	X	X	X	X	X	X	X
7	508-133	Back Assembly	X	X	X	X	X	X	X	X
8	538-215	Fresh Air Damper Assembly	X	X	X	X	X	X	X	X
9	S523-104	Evaporator Drain Pan Assembly	X	X	X	X	X	X	X	X
10	134-154	Wire Channel	X	X	X	X	X	X	X	X
11	140X277	Right Evaporator Support	X	X	X	X	X	X	X	X
12	125-032	Fan Shroud Back	X	X	X	X	X	X	X	X
13	142-055	Condenser Coil Fill	X	X	X	X	X	X	X	X
14	520-376	Condenser Partition Assembly	X	X	X	X	X	X	X	X
15	124X043	Fan Shroud - Right Side	X	X	X	X	X	X	X	X
16	124Y043	Fan Shroud - Left Side	X	X	X	X	X	X	X	X
17	140-229	Condenser Coil Support	2	2	2	2	2	2	2	2
18	S135-177-* ①	Side Trim - Lower	2	2	2	2	2	2	2	2
19	500-392-* ①	Right Side Assembly	X	X	X	X	X	X	X	X
20	140-227	Subcooling Loop Hold Down	3	3	3	3	3	3	3	3
21	123-094	Condenser Drain Pan Assembly	X	X	X	X	X	X	X	X
22	527-309-X	Lower Base Assembly	X	X	X	X	X	X	X	X
23	102-415	Pile Seal Offset	2	2	2	2	2	2	2	2
24	117-240	Lower Control Panel Plate	X	X	X	X	X	X	X	X
25	135-189	Base Shield	X	X	X	X	X	X	X	X
26	140-276	Lower Roller Support	X	X	X	X	X	X	X	X
27	See Page 20	Control Panel Components	X	X	X	X	X	X	X	X
28	133-164	Control Panel Door - Lower	X	X	X	X	X	X	X	X
29	534-155-6	Base Trim Assembly	X	X	X	X	X	X	X	X
30	140-230	Drain Pan Support	X	X	X	X	X	X	X	X

Continued on Page 4

① Exterior cabinet parts are manufactured with various color options. To ensure that you receive the proper color, you must include the complete models and serial number of the unit for which parts are being ordered.

This Table references Exploded View on Page 2

CABINET COMPONENTS

Drawing No.	Part No.	Description	Q24A2-A, -B	Q24A2-C	Q30A2-A, -B	Q30A2-C	Q36A2-A, -B	Q36A2-C	Q42A2-A, -B	Q42A2-C
<i>Continued from Page 3</i>										
31	552-332-* ①	Condenser Door Assembly	X	X	X	X	X	X	X	X
32	140-280	Upper Roller Support	2	2	2	2	2	2	2	2
33	536-351	Condenser Blank Off Plate	X	X	X	X	X	X	X	X
34	552-330-* ①	Filter Door Assembly	X	X	X	X	X	X	X	X
35	153-336-* ①	Circuit Breaker Door	X	X	X	X	X	X	X	X
36	117-238	Lower Control Panel Bottom	X	X	X	X	X	X	X	X
37	132-173	Rotary Disconnect Door Inner		X		X		X		X
37	132-165	Circuit Breaker Door Inner	X		X		X		X	
38	113-305	Left Filter Bracket	X	X	X	X	X	X	X	X
39	552-331-* ①	Blower Door Assembly	X	X	X	X	X	X	X	X
40	113-282	Right Filter Bracket	X	X	X	X	X	X	X	X
41	140Y277	Left Evaporator Support	X	X	X	X	X	X	X	X
43	500-391-* ①	Left Side Assembly	X	X	X	X	X	X	X	X
45	135-165-* ①	Base Trim Extension	2	2	2	2	2	2	2	2
46	112X283	Center Right Filter Bracket	X	X	X	X	X	X	X	X
46	112Y283	Center Left Filter Bracket	X	X	X	X	X	X	X	X
47	See Page 13	Rotary Disconnect Assembly		X		X		X		X
47	See Page 13	Circuit Breaker Box Assembly	X		X		X		X	
48	112-229	Heatstrip Bracket	X	X	X	X	X	X	X	X
49	112-234	Mounting Bracket	2	2	2	2	2	2	2	2
50	S135-178-* ①	Side Trim - Upper	2	2	2	2	2	2	2	2
51	See Page 24	Thermostat Mounting Plate	X	X	X	X	X	X	X	X
52	104-1157	Left Thermostat Support Angle	X	X	X	X	X	X	X	X
54	104-1097	Front Filter Angle	X	X	X	X	X	X	X	X
55	104-1096	Right Thermostat Support Angle	X	X	X	X	X	X	X	X
56	102-434	Sleeve Offset	X	X	X	X	X	X	X	X
57	117-237	Lower Control Panel Top	X	X	X	X	X	X	X	X
58	534-212	Evaporator Coil Shield - Left	X	X	X	X	X	X	X	X
59	103-443	Door Latch Offset	X	X	X	X	X	X	X	X
60	140-282	Transformer Support		X		X		X		X
61	140-369	Compressor Support Plate	X	X	X	X	X	X	X	X
62	141-368	Compressor Support	X	X	X	X	X	X	X	X

① Exterior cabinet parts are manufactured with various color options. To ensure that you receive the proper color, you must include the complete models and serial number of the unit for which parts are being ordered.

This Table references Exploded View on Page 2

CABINET COMPONENTS

Drawing No.	Part No.	Description	Q48A2-A, -B Q60A2-A, -B	Q48A2-C Q60A2-C
1	506-226	Top Assembly	X	X
2	110-044	Outlet Duct Flange	2	2
3	See Page 13	Heater Package Assembly (Optional)	X	X
4	117-283	Low Voltage Box Assembly (Optional)	X	X
5	136-359	T.K.O. Plate	X	X
6	534-195	Evaporator Coil Shield - Right	X	X
7	508-149	Back Assembly	X	X
8	538-215	Fresh Air Damper Assembly	X	X
9	S523-105	Evaporator Drain Pan Assembly	X	X
10	134-154	Wire Channel	X	X
11	140X277	Right Evaporator Support	X	X
12	125-046	Fan Shroud Back	X	X
13	143-066	Condenser Coil Fill	X	X
14	520-377	Condenser Partition Assembly	X	X
15	125-041	Fan Shroud - Right Side	X	X
16	125-045	Fan Shroud - Left Side	X	X
17	140-229	Condenser Coil Support	2	2
18	S135-177-* ①	Side Trim - Lower	2	2
19	500-392-* ①	Right Side Assembly	X	X
20	140-227	Subcooling Loop Hold Down	3	3
21	123-099	Condenser Drain Pan Assembly	X	X
22	527-294-X	Lower Base Assembly	X	X
23	102-415	Pile Seal Offset	2	2
24	117-240	Lower Control Panel Plate	X	X
25	135-194	Base Shield	X	X
26	140-276	Lower Roller Support	X	X
27	See Page 20	Control Panel Components	X	X
28	133-164	Control Panel Door - Lower	X	X
29	534-174-6	Base Trim Assembly	X	X
<i>Continued on Page 6</i>				

① Exterior cabinet parts are manufactured with various color options. To ensure that you receive the proper color, you must include the complete models and serial number of the unit for which parts are being ordered.

This Table references Exploded View on Page 2

CABINET COMPONENTS

Drawing No.	Part No.	Description	Q48A2-A, -B Q60A2-A, -B	Q48A2-C Q60A2-C
<i>Continued from Page 5</i>				
31	552-334-* ①	Condenser Door Assembly	X	X
32	140-224-X	Upper Roller Support	2	2
33	536-351	Condenser Blank Off Plate	X	X
34	552-335-* ①	Filter Door Assembly	X	X
35	153-336-* ①	Circuit Breaker Door	X	X
36	117-238	Lower Control Panel Bottom	X	X
37	132-173	Rotary Disconnect Door Inner		X
37	132-165	Circuit Breaker Door Inner	X	
38	113-305	Left Filter Bracket	X	X
39	552-333-* ①	Blower Door Assembly	X	X
40	113-286	Right Filter Bracket	X	X
41	140Y277	Left Evaporator Support	X	X
42	112-246	Left Mounting Bracket	2	2
43	500-393-* ①	Left Side Assembly	X	X
45	134-165-* ①	Base Trim Extension	2	2
46	112X283	Center Right Filter Bracket	X	X
46	112Y283	Center Left Filter Bracket	X	X
47	See Page 13	Rotary Disconnect Assembly		X
47	See Page 13	Circuit Breaker Box Assembly	X	
48	112-229	Heatstrip Bracket	X	X
49	112-245	Right Mounting Bracket	2	2
50	S135-178-* ①	Side Trim - Upper	2	2
51	See Page 24	Thermostat Mounting Plate	X	X
52	104-1157	Left Thermostat Support Angle	X	X
54	104-1101	Front Filter Angle	X	X
55	104-1096	Right Thermostat Support Angle	X	X
56	102-434	Sleeve Offset	X	X
57	117-237	Lower Control Panel Top	X	X
58	534-212	Evaporator Coil Shield - Left	X	X
59	103-443	Door Latch Offset	X	X
60	140-282	Transformer Support		X
61	140-369	Compressor Support Plate	X	X
62	141-368	Compressor Support	X	X

① Exterior cabinet parts are manufactured with various color options. To ensure that you receive the proper color, you must include the complete models and serial number of the unit for which parts are being ordered.

This Table references Exploded View on Page 2

This page intentionally left blank.

FUNCTIONAL COMPONENTS

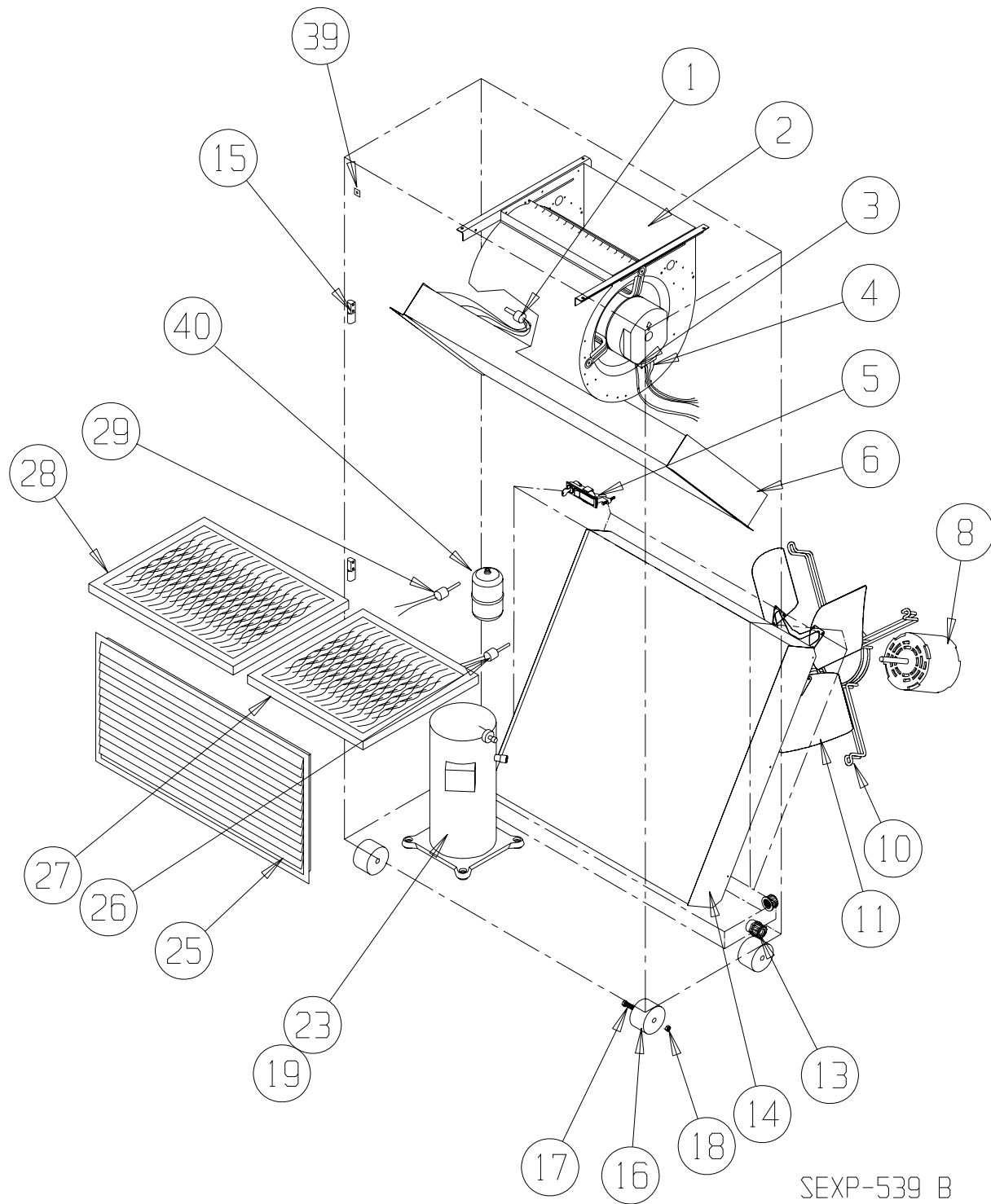

This Exploded View is referenced in Tables on pages 9, 10 & 11

FUNCTIONAL COMPONENTS

Drawing No.	Part No.	Description	Q24A2-A	Q24A2-B	Q24A2-C	Q30A2-A	Q30A2-B	Q30A2-C	Q36A2-A	Q36A2-B	Q36A2-C	Q42A2-A	Q42A2-B	Q42A2-C
1	5625-112	Distributor	X	X	X				X	X	X			
1	5625-111	Distributor												
1	5625-025	Distributor				X	X	X						
1	5625-045	Distributor										X	X	X
2	S900-225-001	Blower Assembly	X	X	X									
2	S900-225-002	Blower Assembly				X	X	X						
2	S900-225-004	Blower Assembly							X	X	X	X	X	X
3	3000-1145	Wire Harness High Voltage			X			X			X			X
3	3000-1046	Wire Harness High Voltage	X	X		X	X		X	X		X	X	
4	3000-1305	Wire Harness Low Voltage	X	X	X	X	X	X	X	X	X	X	X	X
5	1171-049	Keylatch/Circuit Breaker Door	X	X	X	X	X	X	X	X	X	X	X	X
6	5060-118BX	Evaporator Coil	X	X	X	X	X	X						
6	5060-117BX	Evaporator Coil							X	X	X	X	X	X
8	8103-037	Motor	X	X		X	X							
8	8103-038	Motor			X			X						
8	8105-051	Motor							X	X		X	X	
8	8105-052	Motor									X			X
10	8200-001	Motor Mount	X	X	X	X	X	X	X	X	X	X	X	X
11	5151-050	Fan Blade	X	X	X	X	X	X						
11	5151-055	Fan Blade							X	X	X	X	X	X
13	6094-003	Drain Fitting	1	1	1	1	1	1	1	1	1	1	1	1
14	5051-125BX	Condenser Coil	X	X	X									
14	5051-126BX	Condenser Coil				X	X	X	X	X				
14	5051-127BX	Condenser Coil										X	X	X
15	5400-005	Hinge	2	2	2	2	2	2	2	2	2	2	2	2
16	1171-035	Wheel	4	4	4	4	4	4	4	4	4	4	4	4
17	1012-129	Bolt - Shoulder	4	4	4	4	4	4	4	4	4	4	4	4
18	1012-224	Nut - Locking	4	4	4	4	4	4	4	4	4	4	4	4
19	8002-012	Sound Cover	X	X	X	X	X	X	X	X	X	X	X	X
23	8000-314	Compressor	X											
23	8000-315	Compressor		X										
23	8000-316	Compressor			X									
23	8000-298	Compressor				X								
23	8000-299	Compressor					X							
23	8000-300	Compressor						X						
23	8000-278	Compressor							X					
23	8000-283	Compressor								X				
23	8000-342	Compressor									X			
23	8000-318	Compressor										X		
23	8000-319	Compressor											X	
23	8000-320	Compressor												X
25	7051-034	Return Air Grille (for Beige & Buckeye Gray Units)	X	X	X	X	X	X	X	X	X	X	X	X
25	7051-061	Return Air Grille (for Vinyl Units)	X	X	X	X	X	X	X	X	X	X	X	X
26	1804-0462	High Pressure Control	X	X	X	X	X	X	X	X	X	X	X	X
27	7004-009	Air Filter	X	X	X	X	X	X	X	X	X	X	X	X
27	7004-032	Filter 2" Fiberglass (Optional)	X	X	X	X	X	X	X	X	X	X	X	X
27	7004-034	Filter 2" Pleated (Optional)	X	X	X	X	X	X	X	X	X	X	X	X

Continued on Page 10

This Table references Exploded View on Page 8

FUNCTIONAL COMPONENTS

Drawing No.	Part No.	Description	Q24A2-A	Q24A2-B	Q24A2-C	Q30A2-A	Q30A2-B	Q30A2-C	Q36A2-A	Q36A2-B	Q36A2-C	Q42A2-A	Q42A2-B	Q42A2-C
<i>Continued from Page 9</i>														
28	7004-010	Air Filter	X	X	X	X	X	X	X	X	X	X	X	X
28	7004-033	Filter 2" Fiberglass (Optional)	X	X	X	X	X	X	X	X	X	X	X	X
28	7004-035	Filter 2" Pleated (Optional)	X	X	X	X	X	X	X	X	X	X	X	X
29	1804-0386	Low Pressure Control	X	X	X	X	X	X	X	X	X	X	X	X
39	1012-315	"U" Clip Fastener	10	10	10	10	10	10	10	10	10	10	10	10
40	5201-001	Filter Drier	X	X	X	X	X	X						
40	5201-002	Filter Drier							X	X	X	X	X	X
NS	CMA-28	Low Ambient Control	X	X	X	X	X	X	X	X	X	X	X	X
NS	3000-1290	Molded Comp Plug (1 Phase)	X			X			X			X		
NS	3000-1291	Molded Comp Plug (3 Phase)		X	X		X	X		X	X		X	X
NS	4107-104	Unit Wiring Diagram	X			X			X			X		
NS	4107-204	Unit Wiring Diagram		X			X			X			X	
NS	4107-304	Unit Wiring Diagram			X			X			X			X

These Tables reference Exploded View on Page 8

FUNCTIONAL COMPONENTS

Drawing No.	Part No.	Description	Q48A2-A	Q48A2-B	Q48A2-C	Q60A2-A	Q60A2-B	Q60A2-C
1	5625-110	Distributor	X	X	X			
1	5625-109	Distributor				X	X	X
2	S900-225-005	Blower Assembly	X	X	X			
2	S900-254-001	Blower Assembly				X	X	X
3	3000-1145	Wire Harness High Voltage			X			X
3	3000-1046	Wire Harness High Voltage	X	X		X	X	
4	3000-1305	Wire Harness Low Voltage	X	X	X	X	X	X
5	1171-049	Keylatch/Circuit Breaker Door	X	X	X	X	X	X
6	5060-119BX	Evaporator Coil	X	X	X	X	X	X
8	8105-052	Motor			X			X
8	8105-051	Motor	X	X		X	X	
10	8200-001	Motor Mount	X	X	X	X	X	X
11	5151-055	Fan Blade	X	X	X	X	X	X
13	6094-003	Drain Fitting	1	1	1	1	1	1
14	5051-128BX	Condenser Coil	X	X	X	X	X	X
15	5400-005	Hinge	2	2	2	2	2	2
16	1171-035	Wheel	4	4	4	4	4	4
17	1012-129	Bolt - Shoulder	4	4	4	4	4	4
18	1012-224	Nut - Locking	4	4	4	4	4	4
19	8002-012	Sound Cover	X	X	X	X	X	X
23	8000-343	Compressor	X					
23	8000-344	Compressor		X				
23	8000-345	Compressor			X			
23	8000-324	Compressor				X		
23	8000-325	Compressor					X	
23	8000-326	Compressor						X
25	7051-039	Return Air Grille (for Beige & Buckeye Gray Units)	X	X	X	X	X	X
25	7051-063	Return Air Grille (for Vinyl Units)	X	X	X	X	X	X
26	1804-0462	High Pressure Control	X	X	X	X	X	X
27	7004-009	Air Filter	X	X	X	X	X	X
27	7004-032	Filter 2" Fiberglass (Optional)	X	X	X	X	X	X
27	7004-034	Filter 2" Pleated (Optional)	X	X	X	X	X	X
28	7004-011	Air Filter	X	X	X	X	X	X
28	7004-025	Filter 2" Pleated (Optional)	X	X	X	X	X	X
28	7004-036	Filter 2" Fiberglass (Optional)	X	X	X	X	X	X
29	1804-0386	Low Pressure Control	X	X	X	X	X	X
39	1012-315	"U" Clip Fastener	10	10	10	10	10	10
40	5201-002	Filter Drier	X	X	X	X	X	X
NS	CMA-28	Low Ambient Control	X	X	X	X	X	X
NS	3000-1290	Molded Comp Plug (1 Phase)	X			X		
NS	3000-1291	Molded Comp Plug (3 Phase)		X	X		X	X
NS	4107-104	Unit Wiring Diagram	X			X		
NS	4107-204	Unit Wiring Diagram		X			X	
NS	4107-304	Unit Wiring Diagram			X			X

These Tables reference Exploded View on Page 8

This page intentionally left blank.

UPPER CONTROL PANEL COMPONENTS

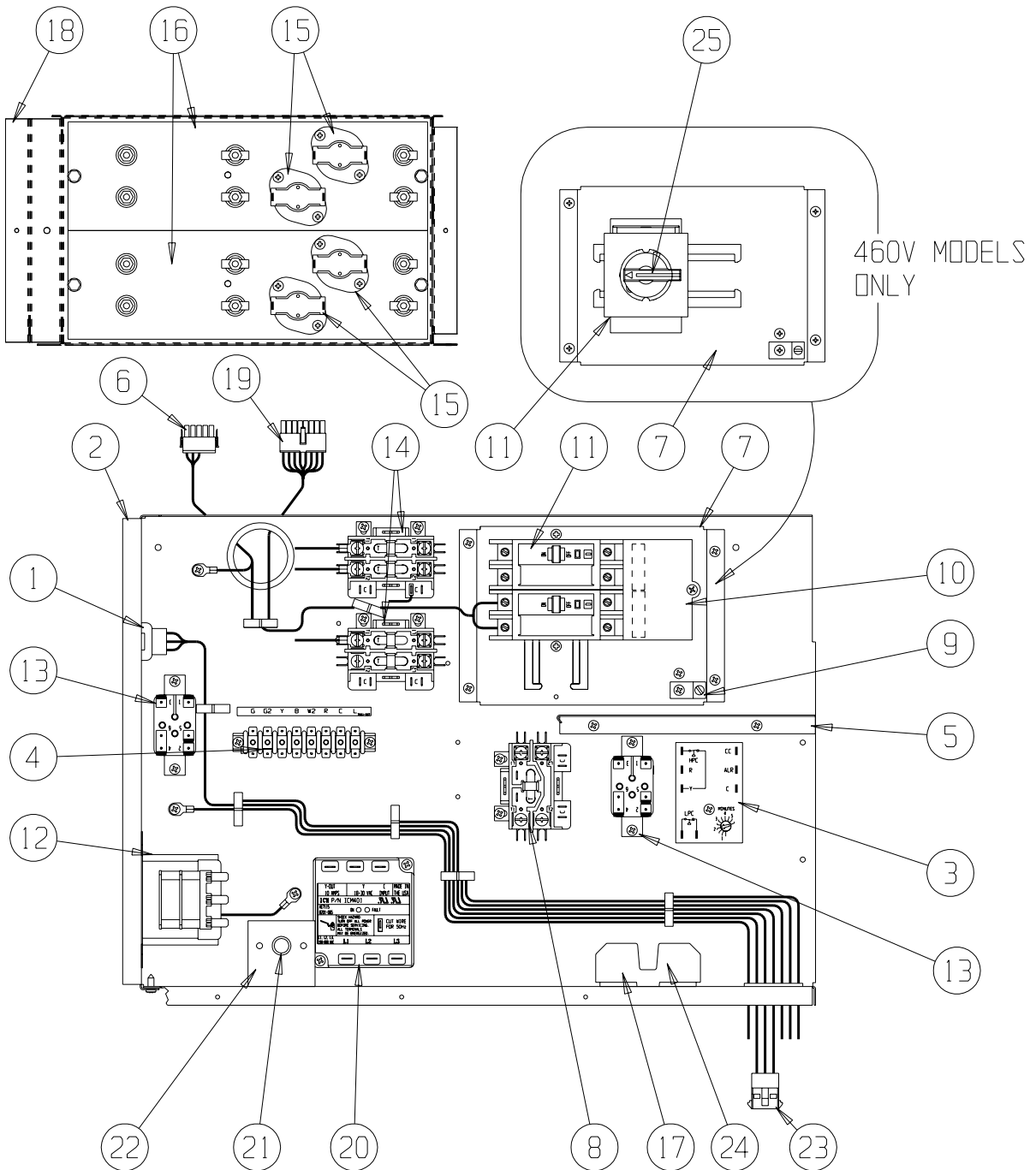

SEXP-423

This Exploded View is referenced in Tables on pages 14,15,16,17,18 & 19

UPPER CONTROL PANEL COMPONENTS

Drawing No.	Part No.	Description	Q24A2-A0Z	Q30A2-A0Z	Q36A2-A0Z	Q42A2-A0Z	Q48A2-A0Z	Q60A2-A0Z	Q24A2-A05	Q30A2-A05	Q36A2-A05	Q42A2-A05	Q48A2-A05	Q24A2-A10	Q30A2-A10	Q36A2-A10	Q42A2-A10	Q48A2-A10	Q60A2-A10	Q36A2-A15	Q42A2-A15	Q48A2-A15	Q60A2-A15
1	3000-1306	Wire Set P2	X	X	X	X	X	X	X	X	X	X	X	X	X	X	X	X	X	X	X	X	X
2	117-241	Control Panel	X	X	X	X	X	X	X	X	X	X	X	X	X	X	X	X	X	X	X	X	X
3	8201-088	Compressor Control Module	X	X	X	X	X	X	X	X	X	X	X	X	X	X	X	X	X	X	X	X	X
4	8607-022	Terminal Block	X	X	X	X	X	X	X	X	X	X	X	X	X	X	X	X	X	X	X	X	X
5	117-242	Box Partition	X	X	X	X	X	X	X	X	X	X	X	X	X	X	X	X	X	X	X	X	X
6	3000-1046	Wire Set Motor HV	X	X	X	X	X	X	X	X	X	X	X	X	X	X	X	X	X	X	X	X	X
7	126-267	Circuit Breaker Base	X	X	X	X	X	X	X	X	X	X	X	X	X	X	X	X	X	X	X	X	X
8	8401-007	Contactor	X	X				X	X			X					X						
8	8401-016	Contactor			X	X					X			X	X					X	X		
9	8611-006	Ground Lug	X	X	X	X	X	X	X	X	X	X	X	X	X	X	X	X	X	X	X	X	X
10	8615-047	Jumper Bar Base																	X	X	X		
11	8615-039	Circuit Breaker 2 Pole 25A Ckt B							X											X	X	X	
11	8615-037	Circuit Breaker 2 Pole 30A Ckt A	X							X													
11	8615-038	Circuit Breaker 2 Pole 35A Ckt A		X						X													
11	8615-055	Circuit Breaker 2 Pole 40A Ckt A									X												
11	8615-039	Circuit Breaker 2 Pole 45A Ckt A				X																	
11	8615-040	Circuit Breaker 2 Pole 50A Ckt A				X																	
11	8615-041	Circuit Breaker 2 Pole 60A Ckt A					X							X	X	X	X	X	X	X	X	X	X
12	8407-035	Transformer	X	X	X	X	X	X	X	X	X	X	X	X	X	X	X	X	X	X	X	X	X
13	8201-062	Relay	X	X	X	X	X	X	X	X	X	X	X	X	X	X	X	X	X	X	X	X	X

Continued on Page 15

This Table references Exploded View on Page 13

UPPER CONTROL PANEL COMPONENTS

Drawing No.	Part No.	Description	Q24A2-A0Z	Q30A2-A0Z	Q36A2-A0Z	Q42A2-A0Z	Q48A2-A0Z	Q60A2-A0Z	Q24A2-A05	Q30A2-A05	Q36A2-A05	Q42A2-A05	Q48A2-A05	Q24A2-A10	Q30A2-A10	Q36A2-A10	Q42A2-A10	Q48A2-A10	Q60A2-A10	Q36A2-A15	Q42A2-A15	Q48A2-A15	Q60A2-A15	
<i>Continued from Page 14</i>																								
14	8401-006	Contactora 2 Pole 20A						X	X	X		X		X					X					
15	8402-100	Limits						X	X	X		2							2		3			
15	8402-131	Limits																						3
16	8604-103	Heat Strip 5KW						X	X	X										X				X
16	8604-104	Heat Strip 10KW										X		X					X	X				X
18	116-191	Heat Strip Wrapper	X	X	X	X	X	X	X	X		X		X					X	X				X
19	3000-1305	Wire Harness Motor LV	X	X	X	X	X	X	X	X		X		X					X	X				X
21	8611-094	Indicator Light	X	X	X	X	X	X	X	X		X		X					X	X				X
22	112-225	Bracket	X	X	X	X	X	X	X	X		X		X					X	X				X
23	3000-1294	Wire Set	X	X	X	X	X	X	X	X		X		X					X	X				X
NS	132-145	Heat Strip Cover						X	X	X		X		X					X	X				X
NS	4108-104	Heat Strip Wiring Diagram	X	X	X	X																		
NS	4108-105	Heat Strip Wiring Diagram						X	X	X														
NS	4108-106	Heat Strip Wiring Diagram										X		X										
NS	4108-107	Heat Strip Wiring Diagram																		X				X

NS = Not Shown

This Table references Exploded View on Page 13

UPPER CONTROL PANEL COMPONENTS

Drawing No.	Part No.	Description	Q24A2-B0Z	Q30A2-B0Z	Q36A2-B0Z	Q42A2-B0Z	Q48A2-B0Z	Q60A2-B0Z	Q24A2-B06	Q30A2-B06	Q36A2-B06	Q42A2-B06	Q48A2-B06	Q24A2-B09	Q30A2-B09	Q36A2-B09	Q42A2-B09	Q48A2-B09	Q60A2-B09	Q30A2-B12	Q36A2-B15	Q42A2-B15	Q48A2-B15	Q60A2-B15
1	3000-1306	Wire Set P2	X	X	X	X	X	X	X	X	X	X	X	X	X	X	X	X	X	X	X	X	X	X
2	117-241	Control Panel	X	X	X	X	X	X	X	X	X	X	X	X	X	X	X	X	X	X	X	X	X	X
3	8201-088	Compressor Control Module	X	X	X	X	X	X	X	X	X	X	X	X	X	X	X	X	X	X	X	X	X	X
4	8607-022	Terminal Block	X	X	X	X	X	X	X	X	X	X	X	X	X	X	X	X	X	X	X	X	X	X
5	117-242	Box Partition	X	X	X	X	X	X	X	X	X	X	X	X	X	X	X	X	X	X	X	X	X	X
6	3000-1046	Wire Set Motor HV	X	X	X	X	X	X	X	X	X	X	X	X	X	X	X	X	X	X	X	X	X	X
7	126-267	Circuit Breaker Base	X	X	X	X	X	X	X	X	X	X	X	X	X	X	X	X	X	X	X	X	X	X
8	8401-002	Contactora	X	X	X	X	X	X	X	X	X	X	X	X	X	X	X	X	X	X	X	X	X	X
9	8611-006	Ground Lug	X	X	X	X	X	X	X	X	X	X	X	X	X	X	X	X	X	X	X	X	X	X
11	8615-054	Circuit Breaker 3 Pole 20A	X																					
11	8615-051	Circuit Breaker 3 Pole 25A		X					X															
11	8615-052	Circuit Breaker 3 Pole 30A							X															
11	8615-042	Circuit Breaker 3 Pole 35A				X				X				X										
11	8615-044	Circuit Breaker 3 Pole 45A					X											X	X					
11	8615-046	Circuit Breaker 3 Pole 60A																			X			X
12	8407-035	Transformer	X	X	X	X	X	X	X	X	X	X	X	X	X	X	X	X	X	X	X	X	X	X
14	8401-006	Contactora 2 Pole 20A							X	X	X	X	X	X	X	X	X	X	X	2		2		2
13	8201-062	Relay	X	X	X	X	X	X	X	X	X	X	X	X	X	X	X	X	X	X	X	X	X	X

Continued on Page 17

This Table references Exploded View on Page 13

UPPER CONTROL PANEL COMPONENTS

Drawing No.	Part No.	Description	Q24A2-B0Z	Q30A2-B0Z	Q36A2-B0Z	Q42A2-B0Z	Q48A2-B0Z	Q60A2-B0Z	Q24A2-B06	Q30A2-B06	Q36A2-B06	Q42A2-B06	Q48A2-B06	Q24A2-B09	Q30A2-B09	Q36A2-B09	Q42A2-B09	Q48A2-B09	Q60A2-B09	Q30A2-B12	Q36A2-B15	Q42A2-B15	Q48A2-B15	Q60A2-B15		
<i>Continued from Page 16</i>																										
15	8402-100	Limits							2	2	2								2	4	4				4	
15	8402-131	Limits																	2							
16	8604-105	Heat Strip 6KW							X	X	X								X	2		X			X	
16	8604-106	Heat Strip 9KW																	X			X			X	
18	161-191	Heat Strip Wrapper	X	X	X	X	X	X	X	X	X			X					X	X		X			X	
19	3000-1305	Wire Harness Motor LV	X	X	X	X	X	X	X	X	X			X					X	X		X			X	
20	8201-126	Phase Monitor	X	X	X	X	X	X	X	X	X			X					X	X		X			X	
21	8611-094	Indicator Light	X	X	X	X	X	X	X	X	X			X					X	X		X			X	
22	112-225	Bracket	X	X	X	X	X	X	X	X	X			X					X	X		X			X	
23	3000-1294	Wire Set PL3	X	X	X	X	X	X	X	X	X			X					X	X		X			X	
NS	132-145	Heat Strip Cover							X	X	X			X					X	X		X			X	
NS	4108-204	Heat Strip Wiring Diagram	X	X	X	X																				
NS	4108-205	Heat Strip Wiring Diagram							X	X	X			X					X							
NS	4108-206	Heat Strip Wiring Diagram																		X		X			X	

NS = Not Shown

This Table references Exploded View on Page 13

UPPER CONTROL PANEL COMPONENTS

Drawing No.	Part No.	Description	Q24A2-C0Z	Q30A2-C0Z	Q36A2-C0Z	Q42A2-C0Z	Q48A2-C0Z	Q60A2-C0Z	Q24A2-C06	Q30A2-C06	Q36A2-C06	Q42A2-C06	Q48A2-C06	Q24A2-C09	Q30A2-C09	Q36A2-C09	Q42A2-C09	Q48A2-C09	Q30A2-C09	Q30A2-C12	Q36A2-C15	Q42A2-C15	Q48A2-C15	Q60A2-C15
1	3000-1306	Wire Set P2	X	X	X				X	X	X	X	X	X	X	X	X	X	X	X	X	X	X	X
2	117-241	Control Panel	X	X	X				X	X	X	X	X	X	X	X	X	X	X	X	X	X	X	X
3	8201-088	Compressor Control Module	X	X	X				X	X	X	X	X	X	X	X	X	X	X	X	X	X	X	X
4	8607-022	Terminal Block	X	X	X				X	X	X	X	X	X	X	X	X	X	X	X	X	X	X	X
5	117-242	Box Partition	X	X	X				X	X	X	X	X	X	X	X	X	X	X	X	X	X	X	X
6	3000-1145	Wire Harness Motor HV	X	X	X				X	X	X	X	X	X	X	X	X	X	X	X	X	X	X	X
7	126-323	Circuit Breaker Base	X	X	X				X	X	X	X	X	X	X	X	X	X	X	X	X	X	X	X
8	8401-002	Contactors	X	X	X				X	X	X	X	X	X	X	X	X	X	X	X	X	X	X	X
9	8611-006	Ground Lug	X	X	X				X	X	X	X	X	X	X	X	X	X	X	X	X	X	X	X
11	8615-068	Rotary Disconnect	X	X	X				X	X	X	X	X	X	X	X	X	X	X	X	X	X	X	X
12	8407-042	Transformer	X	X	X				X	X	X	X	X	X	X	X	X	X	X	X	X	X	X	X
13	8201-062	Relay	X	X	X				X	X	X	X	X	X	X	X	X	X	X	X	X	X	X	X
14	8401-002	Contactors 3 Pole	X	X	X				X	X	X	X	X	X	X	X	X	X	X	X	X	X	X	X
15	8402-100	Limits							2		2					4		4						
15	8402-131	Limits													2									4
16	8604-107	Heat Strip 6KW 480V							X							2		X		2	X	X	X	X
16	8604-108	Heat Strip 9KW 480V									X				X			X			X	X	X	X
17	8614-041	Fuse Holder	X	X	X				X	X	X	X	X	X	X	X	X	X	X	X	X	X	X	X
18	116-191	Heat Strip Wrapper	X	X	X				X	X	X	X	X	X	X	X	X	X	X	X	X	X	X	X

Continued on Page 19

This Table references Exploded View on Page 13

UPPER CONTROL PANEL COMPONENTS

Drawing No.	Part No.	Description	Q24A2-C0Z	Q30A2-C0Z	Q36A2-C0Z	Q42A2-C0Z	Q48A2-C0Z	Q60A2-C0Z	Q24A2-C06	Q30A2-C06	Q36A2-C06	Q42A2-C06	Q48A2-C06	Q24A2-C09	Q30A2-C09	Q36A2-C09	Q42A2-C09	Q48A2-C09	Q60A2-C09	Q30A2-C12	Q36A2-C15	Q42A2-C15	Q48A2-C15	Q60A2-C15
<i>Continued from Page 18</i>																								
19	3000-1305	Wire Harness Motor LV	X	X	X			X			X			X			X		X	X	X	X	X	X
20	8201-126	Phase Monitor	X	X	X	X		X	X	X	X	X	X	X	X	X	X	X	X	X	X	X	X	X
21	8611-094	Indicator Light	X	X	X	X		X	X	X	X	X	X	X	X	X	X	X	X	X	X	X	X	X
22	112-225	Bracket	X	X	X	X		X	X	X	X	X	X	X	X	X	X	X	X	X	X	X	X	X
23	3000-1294	Wire Set PL3	X	X	X	X		X	X	X	X	X	X	X	X	X	X	X	X	X	X	X	X	X
24	8614-042	Fuses Class CC 7A ①						X											X					X
24	8614-046	Fuses Class CC 5A ②			X			X		X		X			X		X		X	X		X		X
24	8614-017	Fuses Class CC 3.2A ③	X		X			X		X		X		X		X		X		X		X		X
25	8615-071	Disconnect Handle	X	X	X	X		X	X	X	X	X	X	X	X	X	X	X	X	X	X	X	X	X
NS	8407-052	Transformer Stepdown 1.0 KVA	X	X				X		X		X		X		X		X		X		X		X
NS	8407-053	Transformer Stepdown 1.5 KVA		X				X		X		X				X		X		X		X		X
NS	8407-054	Transformer Stepdown 2.0 KVA						X								X		X		X		X		X
NS	132-145	Heat Strip Cover								X		X		X		X		X		X		X		X
NS	4108-304	Heat Kit Wiring Diagram	X	X	X																			
NS	4108-305	Heat Kit Wiring Diagram						X		X		X		X		X								
NS	4108-306	Heat Kit Wiring Diagram																	X					
NS	4108-307	Heat Kit Wiring Diagram																				X		X

NS = Not Shown

① 7 Amp fuses used with 2.0 KVA transformer.

② 5 Amp fuses used with 1.5 KVA transformer.

③ 3.2 Amp fuses used with 1KVA transformer.

NS = Not Shown

This Table references Exploded View on Page 13

LOWER CONTROL PANEL COMPONENTS

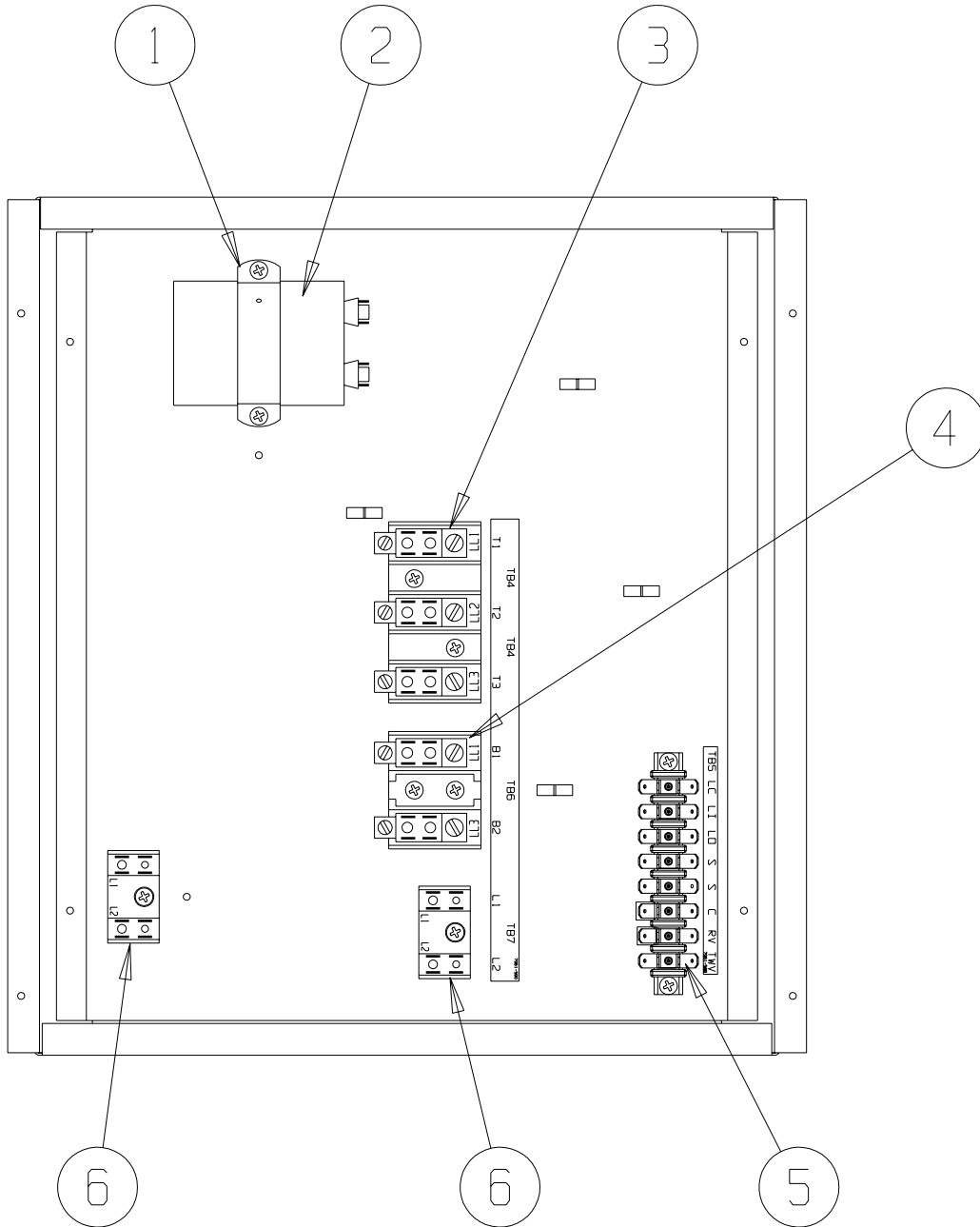

SEXP-424

LOWER CONTROL PANEL COMPONENTS

Drawing No.	Part No.	Description	Q24A2-A	Q30A2-A	Q36A2-A	Q42A2-A	Q48A2-A	Q60A2-A	Q24A2-B	Q30A2-B	Q36A2-B	Q42A2-B	Q48A2-B	Q60A2-B	Q24A2-C	Q30A2-C	Q36A2-C	Q42A2-C	Q48A2-C	Q60A2-C
1	8550-008	Capacitor Strap	X	X	X	X	X	X												
1	8550-003	Capacitor Strap							X										X	
2	8552-002	Fan Capacitor							X										X	
2	8552-050	Compressor Capacitor	X																	
2	8552-052	Compressor Capacitor		X	X	X														
2	8552-081	Compressor Capacitor					X													
2	8552-061	Compressor Capacitor						X												
3	8607-014	Terminal Block 3 Terminal							X										X	
4	8607-013	Terminal Block 2 Terminal	X	X	X	X	X	X											X	
5	8607-022	Terminal Block 8 Position	X	X	X	X	X	X	X										X	
6	8607-017	Terminal Block 2 Terminal	X	X	X	X	X	X	X											2

① Optional on standard models. Standard on low ampacity models.

BLOWER ASSEMBLY COMPONENTS

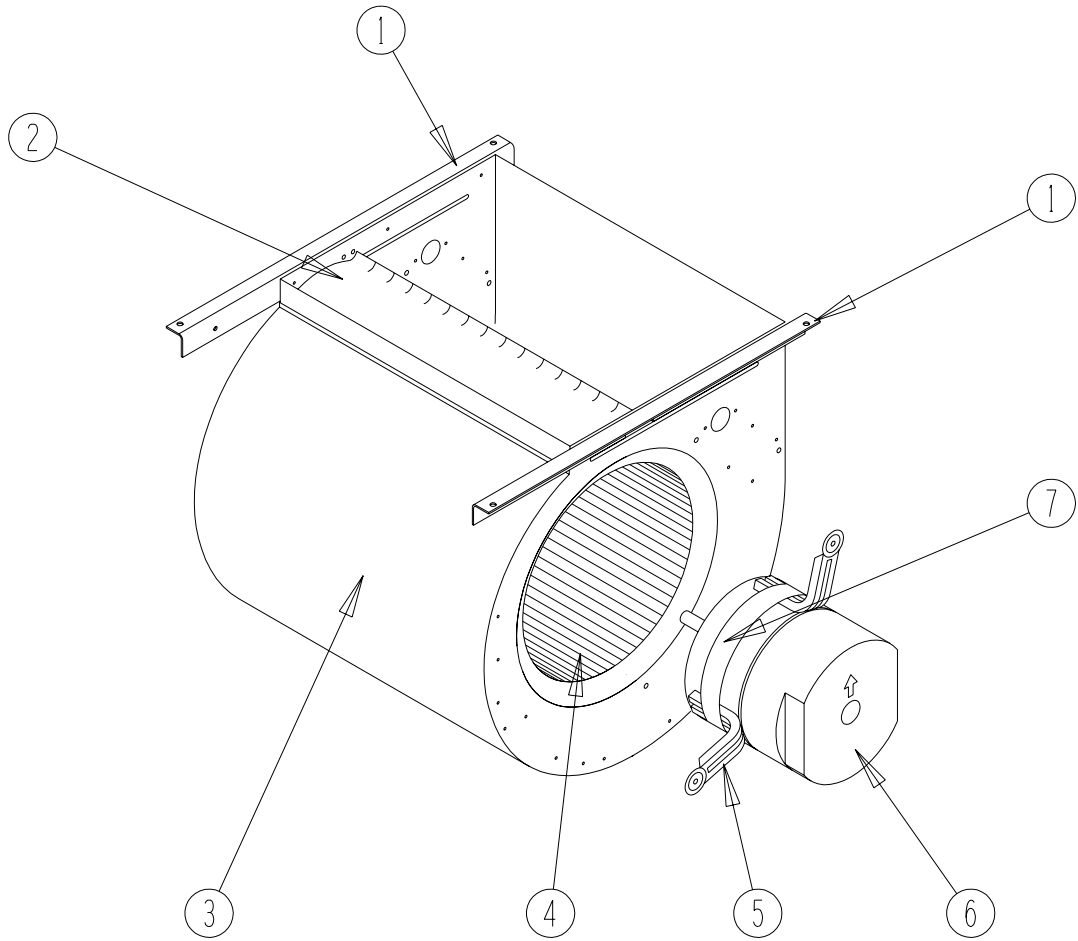

SEXP-245

BLOWER ASSEMBLY COMPONENTS

Drawing No.	Part No.	Description	900-225-001	900-225-002	900-225-004	900-225-005	900-254-001
1	104-980	Blower Angle	2	2	2	2	2
2	144-131	Diffuser	X	X	X	X	X
3	151-110	Blower Housing	X	X	X	X	X
4	5152-061	Blower Wheel	X	X	X	X	X
5	8620-034	Motor Mount Kit	1	1	1	1	1
6	S8106-051-0003B	1/2 HP ECM Motor with Programmed Control	X				
6	C8106-051-0003B	Programmed Motor Control - Only	X				
6	S8106-051-0004A	1/2 HP ECM Motor with Programmed Control		X			
6	C8106-051-0004A	Programmed Motor Control - Only		X			
6	S8106-051-0005B	1/2 HP ECM Motor with Programmed Control			X		
6	C8106-051-0005B	Programmed Motor Control - Only			X		
6	S8106-051-0013A	1/2 HP ECM Motor with Programmed Control				X	
6	C8106-051-0013A	Programmed Motor Control - Only				X	
6	S8107-016-0024B	3/4 HP ECM Motor with Programmed Control					X
6	C8107-016-0024B	Programmed Motor Control - Only					X
7	8620-034	Motor Mount Kit	X	X	X	X	X

OPTIONAL CLIMATE CONTROLS

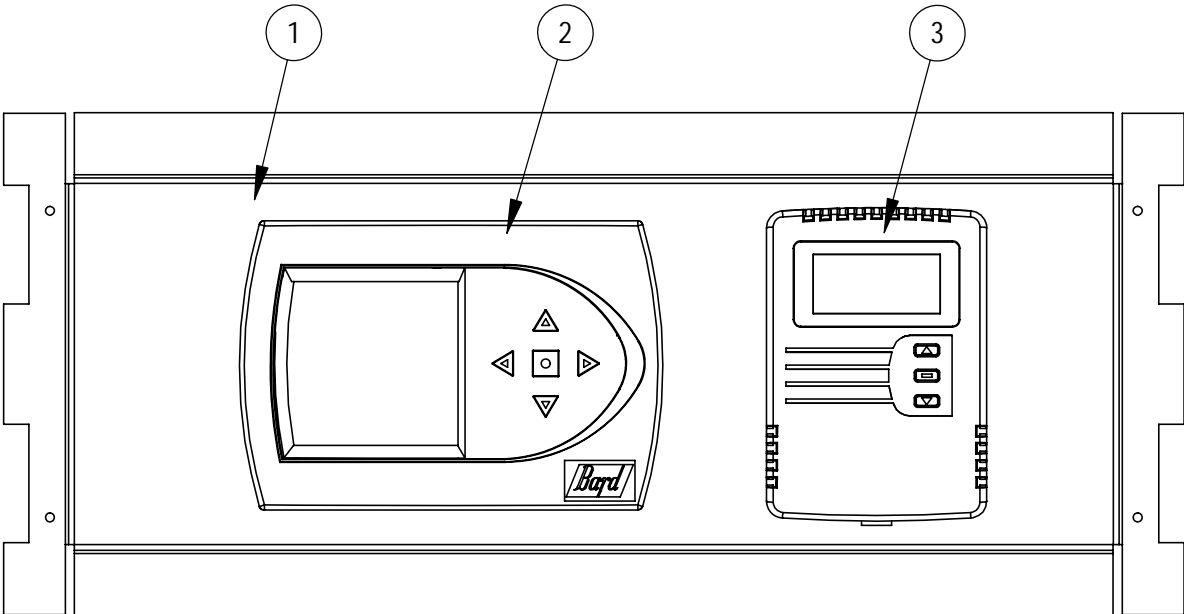

SEXP-704

OPTIONAL CLIMATE CONTROLS

Drawing No.	Part No.	Description	Q24A, Q30A Q36A, Q42A Q48A, Q60A				
			Option X	Option D	Option H	Option B	Option C
1	S127-313-* ①	Thermostat Plate	X				
1	S127-308-* ①	Thermostat Plate		X			
1	S127-372-* ①	Thermostat Plate			X		
1	S127-427-* ①	Thermostat Plate				X	X
2	8403-060	Electronic / Programmable Manual / Auto Changeover		X	X		
2	CS9BE-THO	Temperature, Humidity & Occupancy				X	
2	CS9BE-THOC	Temperature, Humidity, Occupancy & CO2					X
3	8403-067	CO2 Sensor			X		
NS	3000-1301	Wire Harness, Low Voltage, Terminal Strip to PL2	X				
NS	3000-1303	Wire Harness, Thermostat to PL2		X		X	X
NS	3000-1304	Wire Harness			X		
NS	8607-019	Low Voltage Terminal Strip	X				
NS	4102-068	Thermostat Wiring Diagram	X				
NS	4102-070	Thermostat Wiring Diagram		X			
NS	4102-071	Thermostat Wiring Diagram			X		
NS	4102-076	Thermostat Wiring Diagram				X	X

① Exterior cabinet parts are manufactured with various color options. To ensure that you receive the proper color, you must include the complete models and serial number of the unit for which parts are being ordered.

NS Not Shown

CLIMATE CONTROL OPTION NOMENCLATURE AS SHOWN IN UNIT MODEL NUMBER

Q 36A2 - A 09 X X X X X X

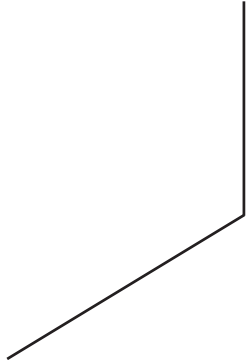

- X – None
- D – Electronic, programmable, manual/auto changeover
- H – Electronic, programmable, manual/auto changeover w/CO₂ controller
- B – Electronic, programmable, manual/auto changeover, Humidistat with BACnet, IP, MS/TP or Ethernet
- C – Electronic, programmable, manual/auto changeover w/CO₂ controller, Humidistat with BACnet, IP, MS/TP or Ethernet

WALL SLEEVE CABINET COMPONENTS

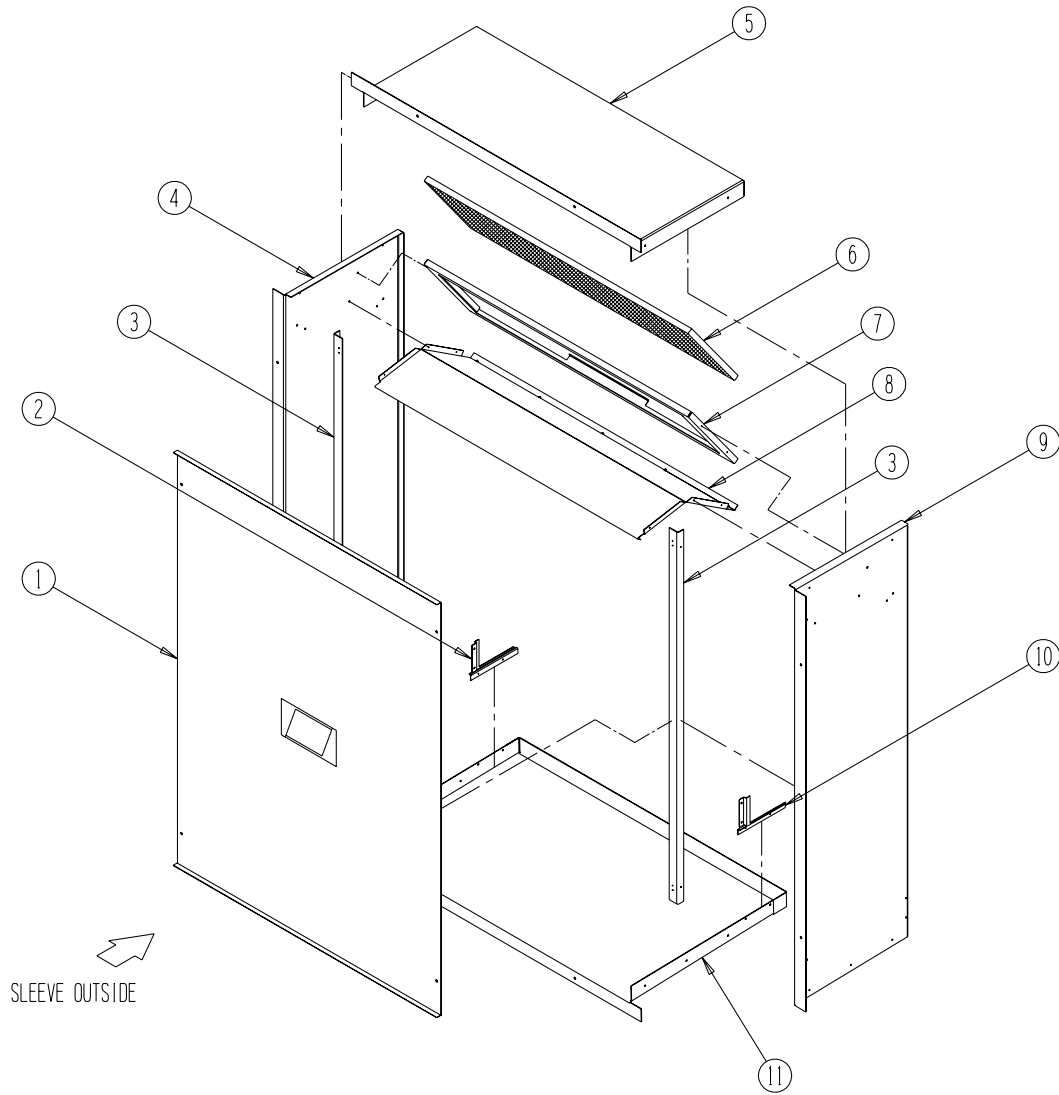

SEXP-281

WALL SLEEVE CABINET COMPONENTS

Drawing No.	Part No.	Description	QWS42A	QWS42A-16	QWS48A	QWS48A-16
1	142-056	Cover	X	X		
1	142-068	Cover			X	X
2	137-450-X	Left Side Seal Angle	X	X	X	X
3	104-988-X	Angle	2	2	2	2
4	111-081-X	Left Side	X		X	
4	111-083-X	Left Side		X		X
5	111-047-X	Top	X			
5	110-050-X	Top		X		
5	110-056-X	Top			X	
5	110-070-X	Top				X
6	7003-044	Mist Eliminator	X	X	X	X
7	131-120-X	Filter Tray	X	X		
7	131-128-X	Filter Tray			X	X
8	121-305-X	Partition	X			
8	121-309-X	Partition		X		
8	121-322-X	Partition			X	
8	121-348-X	Partition				X
9	111-080-X	Right Side	X		X	
9	111-082-X	Right Side		X		X
10	137-449-X	Right Side Seal Angle	X	X		
11	111-046-X	Base	X			
11	111-049-X	Base		X		
11	111-055-X	Base			X	
11	111-071-X	Base				X