

---

# REPLACEMENT PARTS MANUAL

---

## Q-TEC™ SERIES PACKAGED HEAT PUMP

Models:

Q24H2-A Q30H2-A Q36H2-A Q42H2-A Q48H2-A Q60H2-A  
Q24H2-B Q30H2-B Q36H2-B Q42H2-B Q48H2-B Q60H2-B  
Q24H2-C Q30H2-C Q36H2-C Q42H2-C Q48H2-C Q60H2-C

---

### Contents

Description	Page	Description	Page
Cabinet Components		Blower Assembly Components	
♦ Exploded View .....	2	♦ Exploded View .....	20
♦ Usage List .....	3	♦ Usage List .....	21
♦ Usage List .....	4	Optional Climate Control Components	
♦ Usage List .....	5	♦ Layout View .....	22
♦ Usage List .....	6	♦ Usage List .....	23
Functional Components		Wall Sleeve Cabinet Components	
♦ Exploded View .....	8	♦ Exploded View .....	24
♦ Usage List .....	9	♦ Usage List .....	25
♦ Usage List .....	10		
♦ Usage List .....	11		
♦ Usage List .....	12		
Upper Control Panel Components			
♦ Layout View .....	13		
♦ Usage List .....	14		
♦ Usage List .....	15		
♦ Usage List .....	16		
Lower Control Panel Components			
♦ Layout View .....	18		
♦ Usage List .....	19		

### General Notes

- Revised and/or additional pages may be issued from time to time.
- A complete and current manual consists of pages shown in the following contents section.



Bard Manufacturing Company, Inc.  
Bryan, Ohio 43506  
www.bardhvac.com

Manual: 2110-1507C  
Supersedes: 2110-1507B  
Date: 8-22-16

# CABINET COMPONENTS

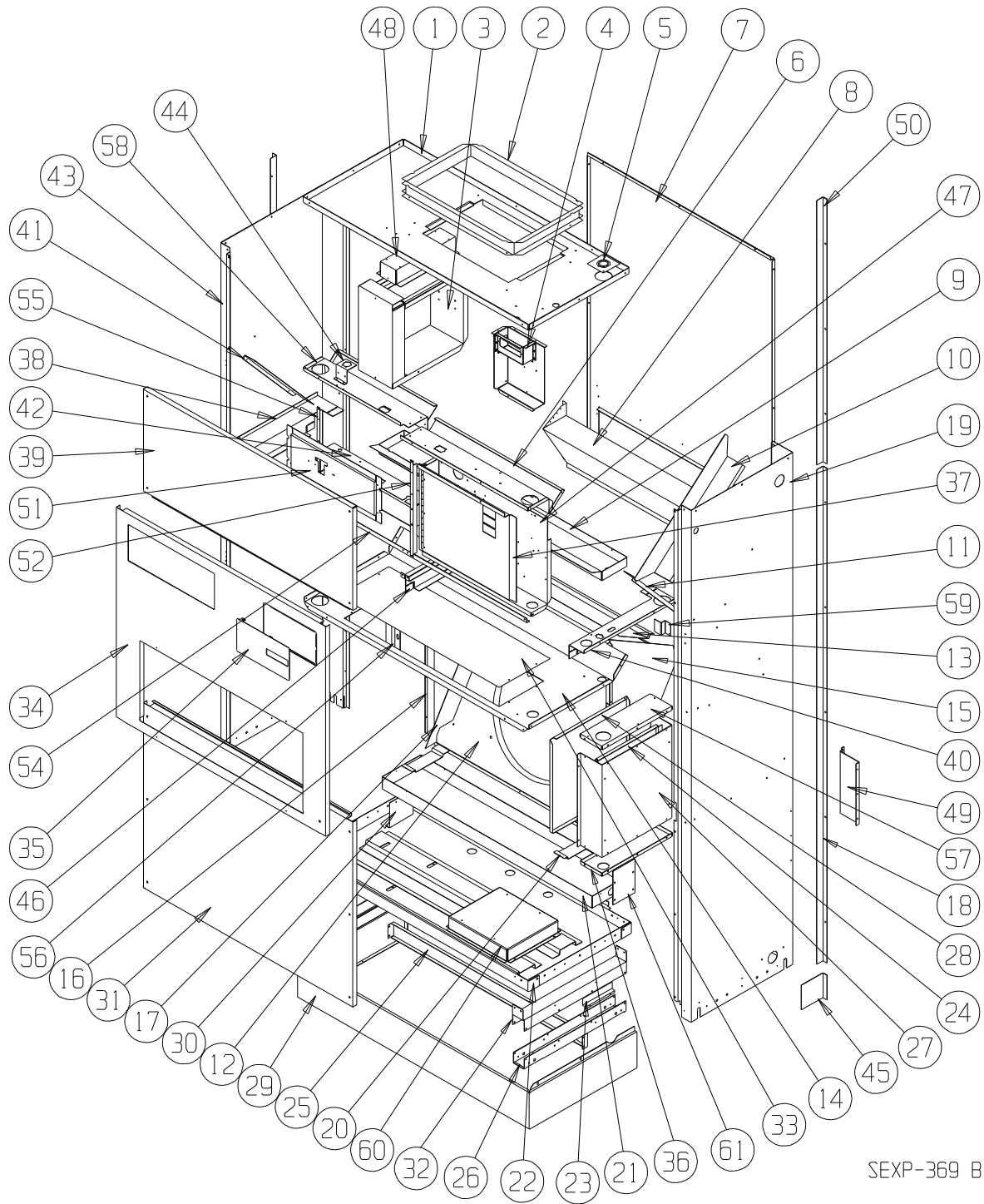

SEXP-369 B

This exploded view is referenced in tables on pages 3, 4, 5 & 6

# CABINET COMPONENTS

Drawing No.	Part No.	Description	Q24H-A, B	Q24H-C	Q30H-A, B	Q30H-C	Q36H-A, -B	Q36H-C	Q42H-A, B	Q42H-C
1	506-225	Top Assembly	X	X	X	X	X	X	X	X
2	110-044	Outlet Duct Flange	2	2	2	2	2	2	2	2
3	See page 13	Heater Package Assembly (Optional)	X	X	X	X	X	X	X	X
4	117-283	Low Voltage Box Assembly (Optional)	X	X	X	X	X	X	X	X
5	136-359	T.K.O. Plate	X	X	X	X	X	X	X	X
6	534-191	Evaporator Coil Shield – Right	X	X	X	X	X	X	X	X
7	508-133	Back Assembly	X	X	X	X	X	X	X	X
8	S538-215	Fresh Air Damper Assembly	X	X	X	X	X	X	X	X
9	S523-104	Evaporator Drain Pan Assembly	X	X	X	X	X	X	X	X
10	134-154	Wire Channel	X	X	X	X	X	X	X	X
11	140X277	Right Evaporator Support	X	X	X	X	X	X	X	X
12	125-032	Fan Shroud Back	X	X	X	X	X	X	X	X
13	142-055	Condenser Coil Fill	X	X	X	X	X	X	X	X
14	520-346	Condenser Partition Assembly	X	X	X	X	X	X	X	X
15	124X043	Fan Shroud Right Side	X	X	X	X	X	X	X	X
16	124Y043	Fan Shroud Left Side	X	X	X	X	X	X	X	X
17	140-229	Condenser Coil Support	2	2	2	2	2	2	2	2
18	S135-177-* ①	Side Trim - Lower	2	2	2	2	2	2	2	2
19	500-392-* ①	Right Side Assembly	X	X	X	X	X	X	X	X
20	140-227	Subcooling Loop Hold Down	3	3	3	3	3	3	3	3
21	123-094	Condenser Drain Pan Assembly	X	X	X	X	X	X	X	X
22	527-309-X	Lower Base Assembly	X	X	X	X	X	X	X	X
23	102-415	Pile Seal Offset	2	2	2	2	2	2	2	2
24	117-240	Lower Control Panel Plate	X	X	X	X	X	X	X	X
25	135-189	Base Shield	X	X	X	X	X	X	X	X
26	140-276	Lower Roller Support	2	2	2	2	2	2	2	2
27	See page 18	Control Panel Components	X	X	X	X	X	X	X	X
28	133-164	Control Panel Door - Lower	X	X	X	X	X	X	X	X
29	534-155-6	Base Trim Assembly	X	X	X	X	X	X	X	X
30	140-230	Drain Pan Support	X	X	X	X	X	X	X	X
31	552-332-* ①	Condenser Door Assembly	X	X	X	X	X	X	X	X
32	140-280	Upper Roller Support	2	2	2	2	2	2	2	2
33	536-351	Condenser Blank Off Plate	X	X	X	X	X	X	X	X

*Continued on page 4*

① Exterior cabinet parts are manufactured with various paint color options. To ensure the proper paint color is received, reference the following codes:

- Beige -X
- Buckeye Gray -4
- Vinyl – Slate Finish -6
- Vinyl – Platinum Finish -7

# CABINET COMPONENTS

Drawing No.	Part No.	Description	Q24H-A, B	Q24H-C	Q30H-A, B	Q30H-C	Q36H-A, -B	Q36H-C	Q42H-A, B	Q42H-C
<i>Continued from page 3</i>										
34	552-330-* ①	Filter Door Assembly	X	X	X	X	X	X	X	X
35	153-336-* ①	Circuit Breaker Door	X	X	X	X	X	X	X	X
36	117-238	Lower Control Panel Bottom	X	X	X	X	X	X	X	X
37	132-173	Disconnect Door Inner		X		X		X		X
37	132-165	Circuit Breaker Door Inner	X		X		X		X	
38	113-281	Left Filter Bracket	X	X	X	X	X	X	X	X
39	552-331-* ①	Blower Door Assembly	X	X	X	X	X	X	X	X
40	113-282	Right Filter Bracket	X	X	X	X	X	X	X	X
41	140Y277	Left Evaporator Support	X	X	X	X	X	X	X	X
43	500-391-* ①	Left Side Assembly	X	X	X	X	X	X	X	X
45	135-165-* ①	Base Trim Extension	2	2	2	2	2	2	2	2
46	112X283	Center Right Filter Bracket	X	X	X	X	X	X	X	X
46	112Y283	Center Left Filter Bracket	X	X	X	X	X	X	X	X
47	See page 13	Pull Disconnect Assembly		X		X		X		X
47	See page 13	Circuit Breaker Box Assembly	X		X		X		X	
48	112-229	Heat Strip Bracket	X	X	X	X	X	X	X	X
49	112-234	Mounting Bracket	2	2	2	2	2	2	2	2
50	S135-178-* ①	Side Trim – Upper	2	2	2	2	2	2	2	2
51	See page 22	Thermostat Mounting Plate	X	X	X	X	X	X	X	X
52	104-1096	Left Thermostat Support Angle	X	X	X	X	X	X	X	X
54	104-1097	Front Filter Angle	X	X	X	X	X	X	X	X
55	104-1096	Right Thermostat Support Angle	X	X	X	X	X	X	X	X
56	102-434	Sleeve Offset	X	X	X	X	X	X	X	X
57	117-237	Lower Control Panel Top	X	X	X	X	X	X	X	X
58	534-190	Evaporator Coil Shield – Left	X	X	X	X	X	X	X	X
59	103-443	Door Latch Offset	X	X	X	X	X	X	X	X
60	140-282	Transformer Support		X		X		X		X
NS	141-368	Compressor Support	X	X	X	X	X	X	X	X
NS	140-369	Compressor Support Plate	X	X	X	X	X	X	X	X

① Exterior cabinet parts are manufactured with various paint color options. To ensure the proper paint color is received, reference the following codes:

Beige -X  
 Buckeye Gray -4  
 Vinyl – Slate Finish -6  
 Vinyl – Platinum Finish -7

This table references exploded view on page 2

# CABINET COMPONENTS

Drawing No.	Part No.	Description	Q48H-A, -B, Q60H-A, -B Q48H-C, Q60H-C	
1	506-226	Top Assembly	X	X
2	110-044	Outlet Duct Flange	2	2
3	See page 13	Heater Package Assembly (Optional)	X	X
4	117-283	Low Voltage Box Assembly (Optional)	X	X
5	136-359	T.K.O. Plate	X	X
6	534-195	Evaporator Coil Shield – Right	X	X
7	508-149	Back Assembly	X	X
8	S538-215	Fresh Air Damper Assembly	X	X
9	S523-105	Evaporator Drain Pan Assembly	X	X
10	134-154	Wire Channel	X	X
11	140X277	Right Evaporator Support	X	X
12	125-046	Fan Shroud Back	X	X
13	143-066	Condenser Coil Fill	X	X
14	520-347	Condenser Partition Assembly	X	X
15	125-041	Fan Shroud Right Side	X	X
16	125-045	Fan Shroud Left Side	X	X
17	140-229	Condenser Coil Support	2	2
18	S135-177-* ①	Side Trim - Lower	2	2
19	500-392-* ①	Right Side Assembly	X	X
20	140-227	Subcooling Loop Hold Down	3	3
21	123-099	Condenser Drain Pan Assembly	X	X
22	527-294-X	Lower Base Assembly	X	X
23	102-415	Pile Seal Offset	2	2
24	117-240	Lower Control Panel Plate	X	X
25	135-194	Base Shield	X	X
26	140-225	Lower Roller Support	2	2
27	See page 18	Control Panel Components	X	X
28	133-164	Control Panel Door - Lower	X	X
29	534-174-6	Base Trim Assembly	X	X
31	552-334-* ①	Condenser Door Assembly	X	X
32	140-224-X	Upper Roller Support	2	2
33	536-351	Condenser Blank Off Plate	X	X
<i>Continued on page 6</i>				

① Exterior cabinet parts are manufactured with various paint color options. To ensure the proper paint color is received, reference the following codes:

Beige -X  
 Buckeye Gray -4  
 Vinyl – Slate Finish -6  
 Vinyl – Platinum Finish -7

**This table references exploded view on page 2**

# CABINET COMPONENTS

Drawing No.	Part No.	Description	Q48H-A, -B, Q60H-A, -B Q48H-C, Q60H-C	
<i>Continued from page 5</i>				
34	552-335-* ①	Filter Door Assembly	X	X
35	153-336-* ①	Circuit Breaker Door	X	X
36	117-238	Lower Control Panel Bottom	X	X
37	132-173	Disconnect Door Inner		X
37	132-165	Circuit Breaker Door Inner	X	
38	113-281	Left Filter Bracket	X	X
39	552-333-* ①	Blower Door Assembly	X	X
40	113-286	Right Filter Bracket	X	X
41	140Y277	Left Evaporator Support	X	X
43	500-393-* ①	Left Side Assembly	X	X
45	134-165-* ①	Base Trim Extension	2	2
46	112X283	Center Right Filter Bracket	X	X
46	112Y283	Center Left Filter Bracke	X	X
47	See page 13	Pull Disconnect Assembly		X
47	See page 13	Circuit Breaker Box Assembly	X	
48	112-229	Heat Strip Bracket	X	X
49	112-245	Right Mounting Bracket	X	X
49	112-246	Left Mounting Bracket	X	X
50	S135-178-* ①	Side Trim – Upper	2	2
51	See page 22	Thermostat Mounting Plate	X	X
52	104-1096	Left Thermostat Support Angle	X	X
54	104-1101	Front Filter Angle	X	X
55	104-1096	Right Thermostat Support Angle	X	X
56	102-434	Sleeve Offset	X	X
57	117-237	Lower Control Panel Top	X	X
58	534-190	Evaporator Coil Shield – Left	X	X
59	103-443	Door Latch Offset	X	X
60	140-282	Transformer Support		X
61	112-372	Motor Control Bracket (Q60H Only)	X	X
NS	141-368	Compressor Support	X	X
NS	140-369	Compressor Support Plate	X	X

① Exterior cabinet parts are manufactured with various paint color options. To ensure the proper paint color is received, reference the following codes:

Beige -X  
 Buckeye Gray -4  
 Vinyl – Slate Finish -6  
 Vinyl – Platinum Finish -7

**This table references exploded view on page 2**

*This page intentionally left blank*

# FUNCTIONAL COMPONENTS

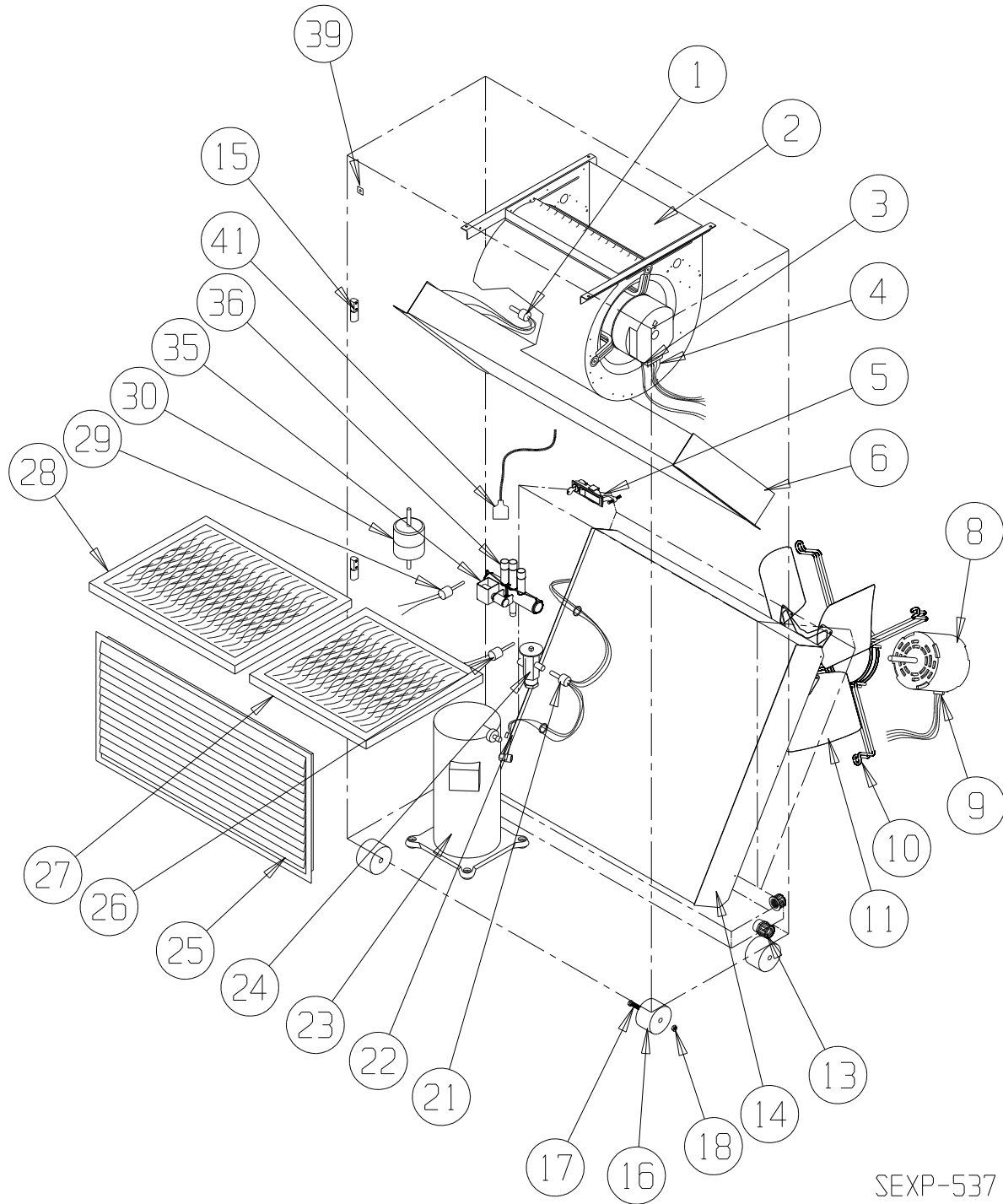

SEXP-537

This exploded view is referenced in tables on pages 9, 10, 11 & 12



# FUNCTIONAL COMPONENTS

Drawing No.	Part No.	Description	Q24H-A	Q24H-B	Q24H-C	Q30H-A	Q30H-B	Q30H-C	Q36H-A	Q36H-B	Q36H-C	Q42H-A	Q42H-B	Q42H-C
1	5625-090	Distributor Cooling	X	X	X									
1	5625-050	Distributor Cooling				X	X	X						
1	5625-046	Distributor Cooling							X	X	X			
1	5625-088	Distributor Cooling										X	X	X
2	S900-225-001	Blower Assembly	X	X	X									
2	S900-225-002	Blower Assembly				X	X	X						
2	S900-225-004	Blower Assembly							X	X	X	X	X	X
3	3000-1145	Wire Harness High Voltage			X			X						
3	3000-1046	Wire Harness High Voltage	X	X		X	X	X	X	X	X	X	X	X
4	3000-1292	Wire Harness Low Voltage	X	X	X	X	X	X	X	X	X	X	X	X
5	1171-049	Keylatch/Circuit Breaker Door	X	X	X	X	X	X	X	X	X	X	X	X
6	5060-093BX	Evaporator Coil	X	X	X									
6	5060-107BX	Evaporator Coil				X	X	X						
6	5060-090BX	Evaporator Coil							X	X	X	X	X	X
8	8103-037	Motor	X	X		X	X							
8	8103-038	Motor			X			X						
8	8105-051	Motor							X	X		X	X	
8	8105-052	Motor									X			X
9	3000-1141	Wire Harness	X	X	X	X	X	X	X	X	X	X	X	X
10	8200-001	Motor Mount	X	X	X	X	X	X	X	X	X	X	X	X
11	5151-050	Fan Blade	X	X	X	X	X	X						
11	5151-055	Fan Blade							X	X	X	X	X	X
13	6094-003	Drain Fitting	1	1	1	1	1	1	1	1	1	1	1	1
14	5051-095BX	Condenser Coil	X	X	X	X	X	X						
14	5051-096BX	Condenser Coil							X	X	X	X	X	X
15	5400-005	Hinge	2	2	2	2	2	2	2	2	2	2	2	2
16	1171-035	Wheel	4	4	4	4	4	4	4	4	4	4	4	4
17	1012-129	Bolt – Shoulder	4	4	4	4	4	4	4	4	4	4	4	4
18	1012-224	Nut – Locking	4	4	4	4	4	4	4	4	4	4	4	4
21	5625-008	Distributor – Heating	X	X	X	X	X	X						
21	5625-010	Distributor – Heating							X	X	X	X	X	X
22	8620-224	Defrost Sensor	X	X	X	X	X	X	X	X	X	X	X	X
23	8000-314	Compressor	X											
23	8000-315	Compressor		X										
23	8000-316	Compressor			X									
23	8000-298	Compressor				X								
23	8000-299	Compressor					X							
23	8000-300	Compressor						X						
23	8000-309	Compressor							X					
23	8000-310	Compressor								X				
23	8000-311	Compressor									X			
23	8000-318	Compressor										X		
23	8000-319	Compressor											X	
23	8000-320	Compressor												X
24	5651-191	TXV Heating	X	X	X									
24	5651-177	TXV Heating				X	X	X						
24	5651-178	TXV Heating							X	X	X	X	X	X

Continued on page 10

# FUNCTIONAL COMPONENTS

Drawing No.	Part No.	Description	Q24H-A	Q24H-B	Q24H-C	Q30H-A	Q30H-B	Q30H-C	Q36H-A	Q36H-B	Q36H-C	Q42H-A	Q42H-B	Q42H-C
<i>Continued from page 9</i>														
25	7051-034	Return Air Grille (for Beige & Buckeye Gray Units)	X	X	X	X	X	X	X	X	X	X	X	X
25	7051-061	Return Air Grille (for Vinyl Units)	X	X	X	X	X	X	X	X	X	X	X	X
26	1804-0462	High Pressure Control	X	X	X	X	X	X	X	X	X	X	X	X
27	7004-009	Air Filter	X	X	X	X	X	X	X	X	X	X	X	X
27	7004-032	Filter 2" Fiberglass (Optional)	X	X	X	X	X	X	X	X	X	X	X	X
27	7004-034	Filter 2" Pleated (Optional)	X	X	X	X	X	X	X	X	X	X	X	X
28	7004-010	Air Filter	X	X	X	X	X	X	X	X	X	X	X	X
28	7004-033	Filter 2" Fiberglass (Optional)	X	X	X	X	X	X	X	X	X	X	X	X
28	7004-035	Filter 2" Pleated (Optional)	X	X	X	X	X	X	X	X	X	X	X	X
29	1804-0107	Low Pressure Control	X	X	X	X	X	X	X	X	X	X	X	X
30	5201-009	Filter/Drier	X	X	X	X	X	X						
30	5201-010	Filter/Drier							X	X	X	X	X	X
35	5650-038	Reversing Valve with Solenoid	X	X	X									
35	5650-039	Reversing Valve with Solenoid				X	X	X						
35	5650-040	Reversing Valve with Solenoid							X	X	X	X	X	X
36	5650-042	Rev. Valve Solenoid, Red Casing (Ranco)	X	X	X	X	X	X	X	X	X	X	X	X
36	5650-043	Rev. Valve Solenoid, Black Casing (Wilspec)	X	X	X	X	X	X	X	X	X	X	X	X
36	5650-046	Rev. Valve Solenoid, Black Casing (San Hua)	X	X	X	X	X	X	X	X	X	X	X	X
39	1012-315	"U" Clip Fastener	10	10	10	10	10	10	10	10	10	10	10	10
41	5650-037	Molded Plug 3/8" Lead	X	X	X	X	X	X	X	X	X	X	X	X
NS	CMA-28	Low Ambient Control	X	X	X	X	X	X	X	X	X	X	X	X
NS	8002-012	Sound Cover	X	X	X	X	X	X	X	X	X	X	X	X
NS	3000-1290	Compressor Wire Harness	X			X			X			X		
NS	3000-1291	Compressor Wire Harness		X	X		X	X		X	X		X	X
NS	4100-121	Unit Wiring Diagram	X			X			X			X		
NS	4100-221	Unit Wiring Diagram		X			X			X			X	
NS	4100-321	Unit Wiring Diagram			X			X			X			X
NS	6031-009	Coremax Valve Core	X	X	X	X	X	X	X	X	X	X	X	X

NS = Not Shown

These tables reference exploded view on page 8

## FUNCTIONAL COMPONENTS

Drawing No.	Part No.	Description	Q48H-A	Q48H-B	Q48H-C	Q60H-A	Q60H-B	Q60H-C
1	5625-093	Cooling Distributor	X	X	X			
1	5625-086	Cooling Distributor				X	X	X
2	S900-225-005	Blower Assembly	X	X	X			
2	S900-254-001	Blower Assembly				X	X	X
3	3000-1145	Wire Harness High Voltage			X			X
3	3000-1046	Wire Harness High Voltage	X	X		X	X	
4	3000-1292	Wire Harness Low Voltage	X	X	X	X	X	X
5	1171-049	Keylatch/Circuit Breaker Door	X	X	X	X	X	X
6	5060-095BX	Evaporator Coil	X	X	X			
6	5060-108BX	Evaporator Coil				X	X	X
8	8105-051	Motor	X	X				
8	8105-052	Motor			X			
8	8106-047	ECM Motor				X	X	X
9	3000-1141	Wire Harness	X	X	X			
10	8200-001	Motor Mount	X	X	X	X	X	X
11	5151-055	Fan Blade	X	X	X	X	X	X
13	6094-003	Drain Fitting	1	1	1	1	1	1
14	5051-162BX	Condenser Coil 28 x 36	X	X	X	X	X	X
NS	5051-161BX	Condenser Coil 8 x 36				X	X	X
15	5400-005	Hinge	2	2	2	2	2	2
16	1171-035	Wheel	4	4	4	4	4	4
17	1012-129	Bolt – Shoulder	4	4	4	4	4	4
18	1012-224	Nut – Locking	4	4	4	4	4	4
21	5625-024	Distributor – Heating	X	X	X	X	X	X
22	8620-224	Defrost Sensor	X	X	X	X	X	X
23	8000-343	Compressor	X					
23	8000-344	Compressor		X				
23	8000-345	Compressor			X			
23	8000-324	Compressor				X		
23	8000-325	Compressor					X	
23	8000-326	Compressor						X
24	5651-178	TXV Heating	X	X	X			
24	5651-184	TXV Heating				X	X	X
25	7051-039	Return Air Grille (for Beige & Buckeye Gray Units)	X	X	X	X	X	X
25	7051-063	Return Air Grille (for Vinyl Units)	X	X	X	X	X	X
26	1804-0462	High Pressure Control	X	X	X	X	X	X
27	7004-009	Air Filter	X	X	X	X	X	X
27	7004-032	Filter 2" Fiberglass (Optional)	X	X	X	X	X	X
27	7004-034	Filter 2" Pleated (Optional)	X	X	X	X	X	X
28	7004-011	Air Filter	X	X	X	X	X	X
28	7004-036	Filter 2" Fiberglass (Optional)	X	X	X	X	X	X
28	7004-025	Filter 2" Pleated (Optional)	X	X	X	X	X	X
29	1804-0107	Low Pressure Control	X	X	X	X	X	X
30	5201-010	Filter/Drier	X	X	X	X	X	X

*Continued on page 12*

**These tables reference exploded view on page 8**

# FUNCTIONAL COMPONENTS

Drawing No.	Part No.	Description	Q48H-A	Q48H-B	Q48H-C	Q60H-A	Q60H-B	Q60H-C
<i>Continued from page 11</i>								
35	5650-040	Reversing Valve	X	X	X	X	X	X
36	5650-042	Rev. Valve Solenoid, Red Casing (Ranco)	X	X	X	X	X	X
36	5650-043	Rev. Valve Solenoid, Black Casing (Wilspec)	X	X	X	X	X	X
36	5650-046	Rev. Valve Solenoid, Black Casing (San Hua)	X	X	X	X	X	X
39	1012-315	"U" Clip Fastener	10	10	10	10	10	10
41	5650-037	Molded Plug 3/8" Lead	X	X	X	X	X	X
NS	CMA-28	Low Ambient Control	X	X	X	X	X	X
NS	5202-026	Suction Accumulator				X	X	X
NS	8002-012	Sound Cover	X	X	X	X	X	X
NS	3000-1290	Compressor Wire Harness	X			X		
NS	3000-1291	Compressor Wire Harness		X	X		X	X
NS	4100-121	Unit Wiring Diagram	X					
NS	4100-221	Unit Wiring Diagram		X				
NS	4100-321	Unit Wiring Diagram			X			
NS	4100-123	Unit Wiring Diagram				X		
NS	4100-223	Unit Wiring Diagram					X	
NS	4100-323	Unit Wiring Diagram						X
NS	6031-009	Coremax Valve Core	X	X	X	X	X	X

NS = Not Shown

This table references exploded view on page 8

# UPPER CONTROL PANEL COMPONENTS

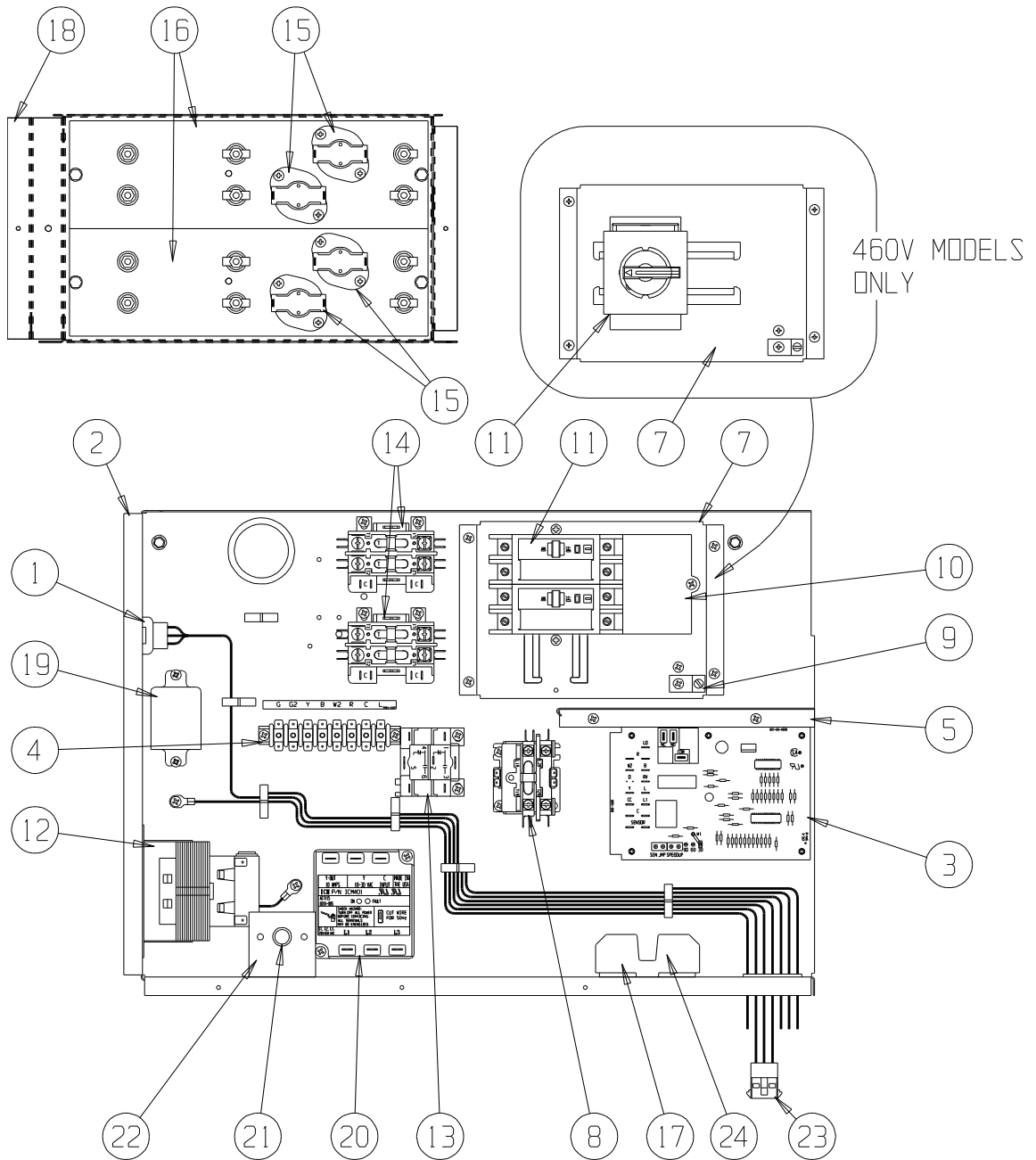

SEXP-373 B

This exploded view is referenced in tables on pages 14, 15 & 16

# UPPER CONTROL PANEL COMPONENTS

Drawing No.	Part No.	Description	Q24H-A0Z	Q30H-A0Z	Q36H-A0Z	Q42H-A0Z	Q48H-A0Z	Q60H-A0Z	Q24H-A05	Q30H-A05	Q36H-A05	Q42H-A05	Q48H-A05	Q60H-A05	Q24H-A10	Q30H-A10	Q36H-A10	Q42H-A10	Q48H-A10	Q36H-A15	Q42H-A15	Q48H-A15	Q60H-A10	Q60H-A15
1	3000-1293	Wire Set P2	X	X	X	X	X	X	X	X	X	X	X	X	X	X	X	X	X	X	X	X	X	X
2	117-241	Control Panel	X	X	X	X	X	X	X	X	X	X	X	X	X	X	X	X	X	X	X	X	X	X
3	8620-223	Heat Pump Control	X	X	X	X	X	X	X	X	X	X	X	X	X	X	X	X	X	X	X	X	X	X
4	8607-022	Terminal Block	X	X	X	X	X	X	X	X	X	X	X	X	X	X	X	X	X	X	X	X	X	X
5	117-242	Box Partition	X	X	X	X	X	X	X	X	X	X	X	X	X	X	X	X	X	X	X	X	X	X
7	126-267	Circuit Breaker Base	X	X	X	X	X	X	X	X	X	X	X	X	X	X	X	X	X	X	X	X	X	X
8	8401-006	Contactor	X	X	X				X	X					X	X				X				
8	8401-025	Contactor				X	X					X	X				X			X	X			
9	8611-006	Ground Lug	X	X	X	X	X	X	X	X	X	X	X	X	X	X	X	X	X	X	X	X	X	X
10	8615-047	Jumper Bar Base											X	X	X	X	X	X	X	X	X	X	X	X
11	8615-036	Circuit Breaker 2 Pole 25A Ckt B											X	X										
11	8615-037	Circuit Breaker 2 Pole 30A Ckt A	X												X									
11	8615-038	Circuit Breaker 2 Pole 35A Ckt A																						
11	8615-055	Circuit Breaker 2 Pole 40A Ckt A															X			X	X			
11	8615-039	Circuit Breaker 2 Pole 45A Ckt A			X																			
11	8615-040	Circuit Breaker 2 Pole 50A Ckt A				X	X		X								X	X		X	X			
11	8615-040	Circuit Breaker 2 Pole 50A Ckt B													X	X	X	X		X	X	X	X	X
11	8615-041	Circuit Breaker 2 Pole 60A Ckt A						X		X				X							X	X	X	X
12	8407-048	Transformer	X	X	X	X	X	X	X	X	X	X	X	X	X	X	X	X	X	X	X	X	X	X
14	8401-006	Contactor							X	X	X	X								X	X			X
14	8401-025	Contactor													X	X	X	X		X	X	X	X	X
15	8402-100	Limits							1	1	1				2	2	2	3	3				2	3
15	8402-131	Limits												1										
16	8604-103	Heat Strip 5KW							X	X	X	X							X	X			X	X
16	8604-104	Heat Strip 10 KW													X	X			X	X	X	X	X	X
18	116-191	Heat Strip Wrapper							X	X	X	X	X	X	X	X	X	X	X	X	X	X	X	X
19	8201-048	Relay							X	X	X	X	X	X	X	X	X	X	X	X	X	X	X	X
21	8611-094	Indicator Light	X	X	X	X	X	X	X	X	X	X	X	X	X	X	X	X	X	X	X	X	X	X
22	112-225	Bracket	X	X	X	X	X	X	X	X	X	X	X	X	X	X	X	X	X	X	X	X	X	X
23	3000-1294	Wire Set	X	X	X	X	X	X	X	X	X	X	X	X	X	X	X	X	X	X	X	X	X	X
NS	8201-015	Staging Relay SR																						
NS	132-145	Heat Strip Cover							X	X	X	X	X	X	X	X	X	X	X	X	X	X	X	X
NS	4101-118	Heat Kit Wiring Diagram	X	X	X	X	X																	
NS	4101-114	Heat Kit Wiring Diagram							X	X														
NS	4101-115	Heat Kit Wiring Diagram													X	X	X						X	
NS	4101-116	Heat Kit Wiring Diagram																	X	X				X
NS	4101-117	Heat Kit Wiring Diagram											X	X										

NS = Not Shown

This table references exploded view on page 13

## UPPER CONTROL PANEL COMPONENTS

Drawing No.	Part No.	Description	Q24H-B0Z	Q30H-B0Z	Q36H-B0Z	Q42H-B0Z	Q48H-B0Z	Q60H-B0Z	Q24H-B06	Q30H-B06	Q36H-B06	Q42H-B06	Q48H-B06	Q24H-B09	Q30H-B09	Q36H-B09	Q42H-B09	Q48H-B09	Q30H-B12	Q36H-B15	Q42H-B15	Q48H-B15	Q60H-B09	Q60H-B15
1	3000-1293	Wire Set P2	X	X	X	X	X	X	X	X	X	X	X	X	X	X	X	X	X	X	X	X	X	X
2	117-241	Control Panel	X	X	X	X	X	X	X	X	X	X	X	X	X	X	X	X	X	X	X	X	X	X
3	8620-223	Heat Pump Control	X	X	X	X	X	X	X	X	X	X	X	X	X	X	X	X	X	X	X	X	X	X
4	8607-022	Terminal Block	X	X	X	X	X	X	X	X	X	X	X	X	X	X	X	X	X	X	X	X	X	X
5	117-242	Box Partition	X	X	X	X	X	X	X	X	X	X	X	X	X	X	X	X	X	X	X	X	X	X
7	126-269	Circuit Breaker Base	X	X	X	X	X	X	X	X	X	X	X	X	X	X	X	X	X	X	X	X	X	X
8	8401-006	Contactors	X	X	X	X	X	X	X	X	X	X	X	X	X	X	X	X	X	X	X	X	X	X
9	8611-006	Ground Lug	X	X	X	X	X	X	X	X	X	X	X	X	X	X	X	X	X	X	X	X	X	X
11	8615-054	Circuit Breaker 3 Pole 20A	X																					
11	8615-051	Circuit Breaker 3 Pole 25A		X																				
11	8615-052	Circuit Breaker 3 Pole 30A			X																			
11	8615-042	Circuit Breaker 3 Pole 35A				X		X																
11	8615-043	Circuit Breaker 3 Pole 40A							X															
11	8615-044	Circuit Breaker 3 Pole 45A								X				X										
11	8615-045	Circuit Breaker 3 Pole 50A									X				X									
11	8615-046	Circuit Breaker 3 Pole 60A										X				X	X		X	X			X	X
12	8407-048	Transformer	X	X	X	X	X	X	X	X	X	X	X	X	X	X	X	X	X	X	X	X	X	X
14	8401-002	Contactors							X	X	X	X	X	X	X	X	X	2	2	2	2	X	2	2
15	8402-100	Limits							2	2	2	2	2	2	2	2	2	4	4	4	4			
15	8402-131	Limits																				X	4	4
16	8604-105	Heat Strip 6 KW							X	X	X								2	X	X	X	X	X
16	8604-106	Heat Strip 9 KW												X	X	X	X			X	X	X	X	X
18	116-191	Heat Strip Wrapper							X	X	X	X	X	X	X	X	X	X	X	X	X	X	X	X
19	8201-048	Relay							X	X	X	X	X	X	X	X	X	X	X	X	X	X	X	X
20	8201-126	Phase Monitor	X	X	X	X	X	X	X	X	X	X	X	X	X	X	X	X	X	X	X	X	X	X
21	8611-094	Indicator Light	X	X	X	X	X	X	X	X	X	X	X	X	X	X	X	X	X	X	X	X	X	X
22	112-225	Bracket	X	X	X	X	X	X	X	X	X	X	X	X	X	X	X	X	X	X	X	X	X	X
23	3000-1294	Wire Set PL3	X	X	X	X	X	X	X	X	X	X	X	X	X	X	X	X	X	X	X	X	X	X
NS	8201-015	Staging Relay SR																						
NS	132-145	Heat Strip Cover							X	X	X	X	X	X	X	X	X	X	X	X	X	X	X	X
NS	4101-210	Heat Kit Wiring Diagram	X	X	X	X																		
NS	4101-211	Heat Kit Wiring Diagram							X	X	X	X	X	X	X	X	X					X		
NS	4101-213	Heat Kit Wiring Diagram																		X				X
NS	4101-212	Heat Kit Wiring Diagram																X						

NS = Not Shown

This table references exploded view on page 13

# UPPER CONTROL PANEL COMPONENTS

Drawing No.	Part No.	Description	Q24H-C0Z	Q30H-C0Z	Q36H-C0Z	Q42H-C0Z	Q48H-C0Z	Q60H-C0Z	Q24H-C06	Q30H-C06	Q36H-C06	Q42H-C06	Q48H-C06	Q24H-C09	Q30H-C09	Q36H-C09	Q42H-C09	Q48H-C09	Q30H-C12	Q36H-C15	Q42H-C15	Q48H-C15	Q60H-C15
1	3000-1293	Wire Set P2	X	X	X	X	X	X	X	X	X	X	X	X	X	X	X	X	X	X	X	X	X
2	117-241	Control Panel	X	X	X	X	X	X	X	X	X	X	X	X	X	X	X	X	X	X	X	X	X
3	8620-223	Heat Pump Control	X	X	X	X	X	X	X	X	X	X	X	X	X	X	X	X	X	X	X	X	X
4	8607-022	Terminal Block	X	X	X	X	X	X	X	X	X	X	X	X	X	X	X	X	X	X	X	X	X
5	117-242	Box Partition	X	X	X	X	X	X	X	X	X	X	X	X	X	X	X	X	X	X	X	X	X
6	8201-078	Low Pressure TDR	X	X	X	X	X	X	X	X	X	X	X	X	X	X	X	X	X	X	X	X	X
7	126-323	Circuit Breaker Base	X	X	X	X	X	X	X	X	X	X	X	X	X	X	X	X	X	X	X	X	X
8	8401-002	Contactors	X	X	X	X	X	X	X	X	X	X	X	X	X	X	X	X	X	X	X	X	X
9	8611-006	Ground Lug	X	X	X	X	X	X	X	X	X	X	X	X	X	X	X	X	X	X	X	X	X
11	S8615-068	Disconnect	X	X	X	X	X	X	X	X	X	X	X	X	X	X	X	X	X	X	X	X	X
12	8407-048	Transformer	X	X	X	X	X	X	X	X	X	X	X	X	X	X	X	X	X	X	X	X	X
13	8201-032	Relay OMR	X	X	X	X	X	X	X	X	X	X	X	X	X	X	X	X	X	X	X	X	X
14	8401-002	Contactors 3 Pole 25A		X	X	X	X	X	X	2	2	2	2	2	2	2	2	2	2	2	2	2	2
15	8402-100	Limits						2	2	2	2	2	2	2	2	2	2	2	2	2	2	2	2
15	8402-131	Limits																					4
16	8604-107	Heat Strip 6KW 480V							X										2	X	X	X	X
16	8604-108	Heat Strip 9KW 480V												X						X	X	X	X
17	8614-041	Fuse Holder	X	X	X	X	X	X	X	X	X	X	X	X	X	X	X	X	X	X	X	X	X
18	116-191	Heat Strip Wrapper							X		X	X	X	X	X	X	X	X	X	X	X	X	X
19	8201-048	Relay							X		X	X	X	X	X	X	X	X	X	X	X	X	X
20	8201-126	Phase Monitor	X	X	X	X	X	X	X	X	X	X	X	X	X	X	X	X	X	X	X	X	X
21	8611-094	Indicator Light	X	X	X	X	X	X	X	X	X	X	X	X	X	X	X	X	X	X	X	X	X
22	112-225	Bracket	X	X	X	X	X	X	X	X	X	X	X	X	X	X	X	X	X	X	X	X	X
23	3000-1294	Wire Set PL3	X	X	X	X	X	X	X	X	X	X	X	X	X	X	X	X	X	X	X	X	X
24	8614-042	Fuses Class CC 7A ①	X						X		X	X	X	X	X	X	X	X	X	X	X	X	X
24	8614-046	Fuses Class CC 5A ②	X	X					X		X	X	X	X	X	X	X	X	X	X	X	X	X
24	8614-047	Fuses Class CC 3.2A ③	X	X					X		X	X	X	X	X	X	X	X	X	X	X	X	X
25	8615-071	Disconnect Handle	X	X	X	X	X	X	X	X	X	X	X	X	X	X	X	X	X	X	X	X	X
NS	8407-058	Transformer Stepdown 1.0 KVA	X						X		X	X	X	X	X	X	X	X	X	X	X	X	X
NS	8407-003	Transformer Stepdown 1.5 KVA	X	X					X		X	X	X	X	X	X	X	X	X	X	X	X	X
NS	8407-004	Transformer Stepdown 2.0 KVA	X	X					X		X	X	X	X	X	X	X	X	X	X	X	X	X
NS	8201-015	Staging Relay																					
NS	132-145	Heat Strip Cover							X		X	X	X	X	X	X	X	X	X	X	X	X	X
NS	4101-310	Heat Kit Wiring Diagram	X	X																			
NS	4101-311	Heat Kit Wiring Diagram							X		X	X	X	X	X	X	X	X	X	X	X	X	X
NS	4101-313	Heat Kit Wiring Diagram																			X	X	X
NS	4101-312	Heat Kit Wiring Diagram																	X				

① 7 Amp fuses used with 2.0 KVA transformer.

② 5 Amp fuses used with 1.5 KVA transformer.

③ 3.2 Amp fuses used with 1 KVA transformer.

NS = Not Shown

**This table references exploded view on page 13**



*This page intentionally left blank*

# LOWER CONTROL PANEL COMPONENTS

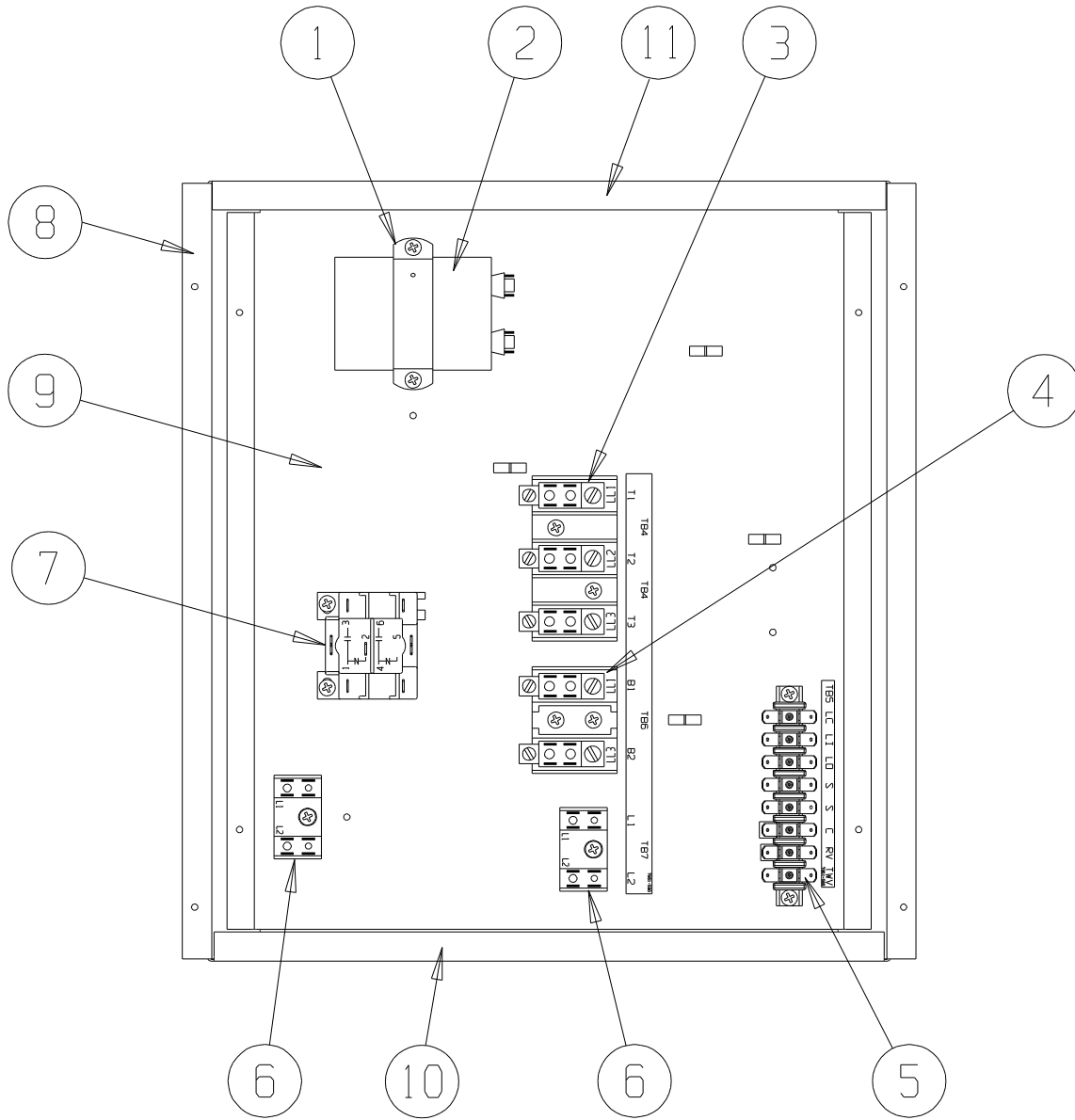

SEXP-374 A

## LOWER CONTROL PANEL COMPONENTS

Drawing No.	Part No.	Description	Q24H-A	Q30H-A	Q36H-A	Q42H-A	Q48H-A	Q60H-A	Q24H - Q48H-B	Q60H-B	Q24H - Q48H-C	Q60H-C
1	8550-008	Capacitor Strap	X	X	X	X	X	X				
1	8550-003	Capacitor Strap							X		X	
2	8552-002	Fan Capacitor							X		X	
2	8552-050	Compressor Capacitor	X									
2	8552-052	Compressor Capacitor		X	X	X						
2	8552-081	Compressor Capacitor					X					
2	8552-088	Compressor Capacitor						X				
3	8607-014	Terminal Block 3 Terminal							X	X	X	X
4	8607-013	Terminal Block 2 Terminal	X	X	X	X	X	X			X	X
5	8607-022	Terminal Block 8 Pos	X	X	X	X	X	X	X	X	X	X
6	8607-017	Terminal Block 2 Terminal	X	X	X	X	X	X	X	X	X	X
7	8201-032	Low Ambient Bypass Relay (Optional)	X	X	X	X	X	X	X	X	X	X
8	117-239	Lower Control Panel	X	X	X	X	X	X	X	X	X	X
9	117-240	Lower Control Panel Plate	X	X	X	X	X	X	X	X	X	X
10	117-238	Lower Control Panel Bottom	X	X	X	X	X	X	X	X	X	X
11	117-237	Lower Control Panel Top	X	X	X	X	X	X	X	X	X	X

# BLOWER ASSEMBLY COMPONENTS

---

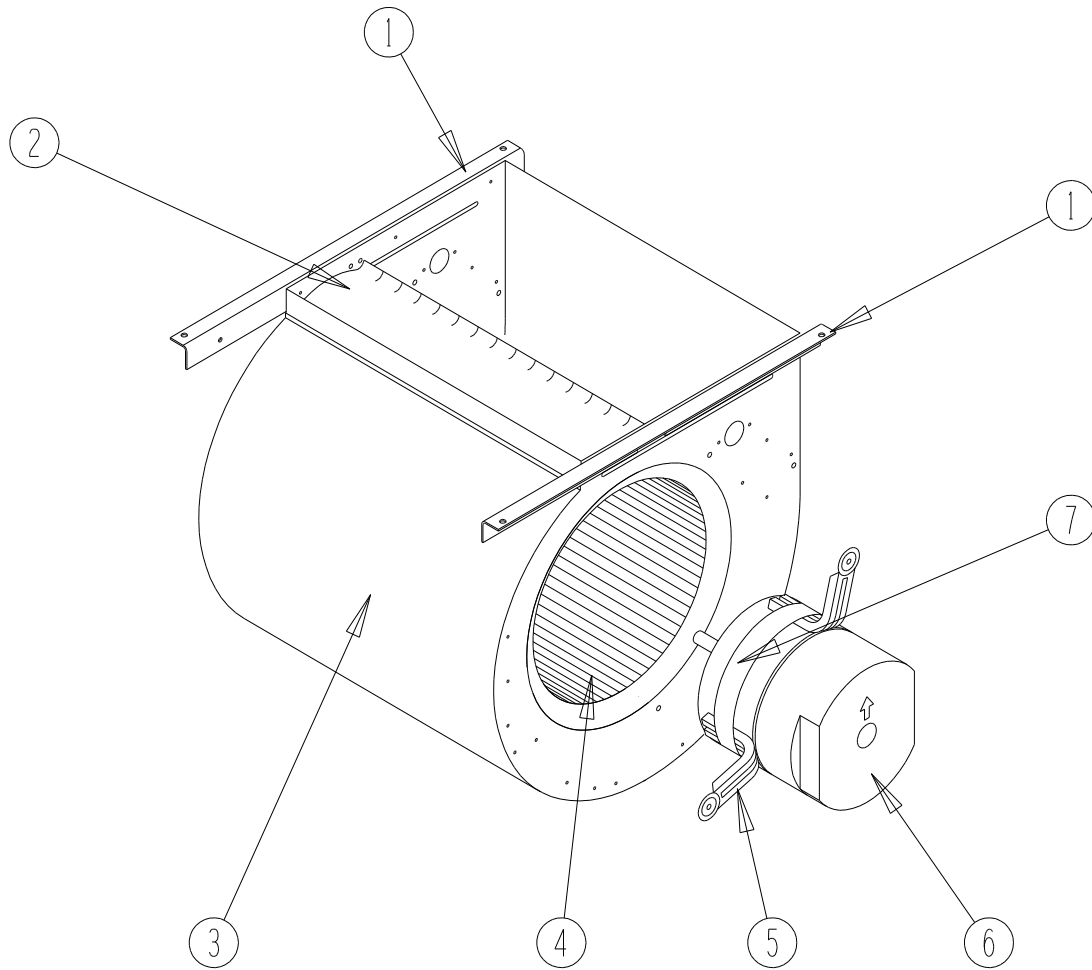

SEXP-245

## BLOWER ASSEMBLY COMPONENTS

Drawing No.	Part No.	Description	900-225-001	900-225-002	900-225-004	900-225-005	900-254-001
1	104-980	Blower Angle	2	2	2	2	2
2	144-131	Diffuser	X	X	X	X	X
3	151-110	Blower Housing	X	X	X	X	X
4	5152-061	Blower Wheel	X	X	X	X	X
5	8620-034	Motor Mount Kit	1	1	1	1	1
6	S8106-051-0003B	1/2 HP ECM Motor with Programmed Control	X				
6	C8106-051-0003B	Programmed Motor Control - Only	X				
6	S8106-051-0004A	1/2 HP ECM Motor with Programmed Control		X			
6	C8106-051-0004A	Programmed Motor Control - Only		X			
6	S8106-051-0005B	1/2 HP ECM Motor with Programmed Control			X		
6	C8106-051-0005B	Programmed Motor Control - Only			X		
6	S8106-051-0013A	1/2 HP ECM Motor with Programmed Control				X	
6	C8106-051-0013A	Programmed Motor Control - Only				X	
6	S8107-016-0024B	3/4 HP ECM Motor with Programmed Control					X
6	C8107-016-0024B	Programmed Motor Control - Only					X
7	8620-034	Motor Mount	X	X	X	X	X

# OPTIONAL CLIMATE CONTROLS

---

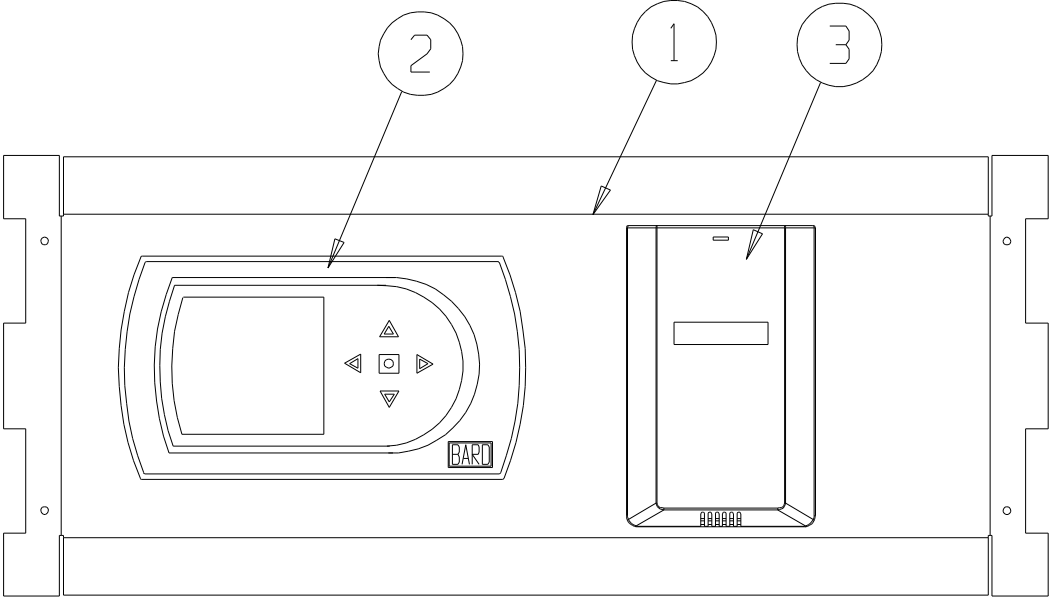

SEXP-0497 A

## OPTIONAL CLIMATE CONTROLS

Drawing No.	Part No.	Description	Q24H, Q30H Q36H, Q42H Q48H, Q60H				
			Option X	Option D	Option H	Option B	Option C
1	S127-313-* ①	Thermostat Plate	X				
1	S127-308-* ①	Thermostat Plate		X			
1	S127-372-* ①	Thermostat Plate			X		
1	S127-426-* ①	Thermostat Plate				X	X
2	8403-060	Electronic/Programmable Manual / Auto Changeover		X	X		
2	CS9BE-THO	Temperature, Humidity, Occupancy, BACnet				X	
2	CS9BE-THOC	Temperature, Humidity, Occupancy, BACnet, CO2					X
3	8403-067	CO2 Sensor			X		
NS	3000-1289	Wire Harness, Low Voltage, Terminal Strip to PL2	X				
NS	3000-1288	Wire Harness, Thermostat to PL2		X		X	X
NS	3000-1287	Wire Harness			X		
NS	8607-019	Low Voltage Terminal Strip	X				
NS	4102-061	Wiring Diagram	X				
NS	4102-060	Wiring Diagram		X			
NS	4102-059	Wiring Diagram			X		
NS	4102-078	Wiring Diagram				X	X

① Exterior cabinet parts are manufactured with various paint color options. To ensure the proper paint color is received, reference the following codes:

- Beige -X
- Buckeye Gray -4
- Vinyl - Slate Finish -6
- Vinyl - Platinum Finish -7

NS Not Shown

CLIMATE CONTROL OPTION NOMENCLATURE AS SHOWN IN UNIT MODEL NUMBER

Q 36H2 - A 09 X X X X X

- X – None
- D – Electronic, programmable, manual/auto changeover
- H – Electronic, programmable, manual/auto changeover with CO<sub>2</sub> controller
- B – Electronic, programmable, manual/auto changeover with BACnet
- C – Electronic, programmable, manual/auto changeover with CO<sub>2</sub> & BACnet

# WALL SLEEVE CABINET COMPONENTS

---

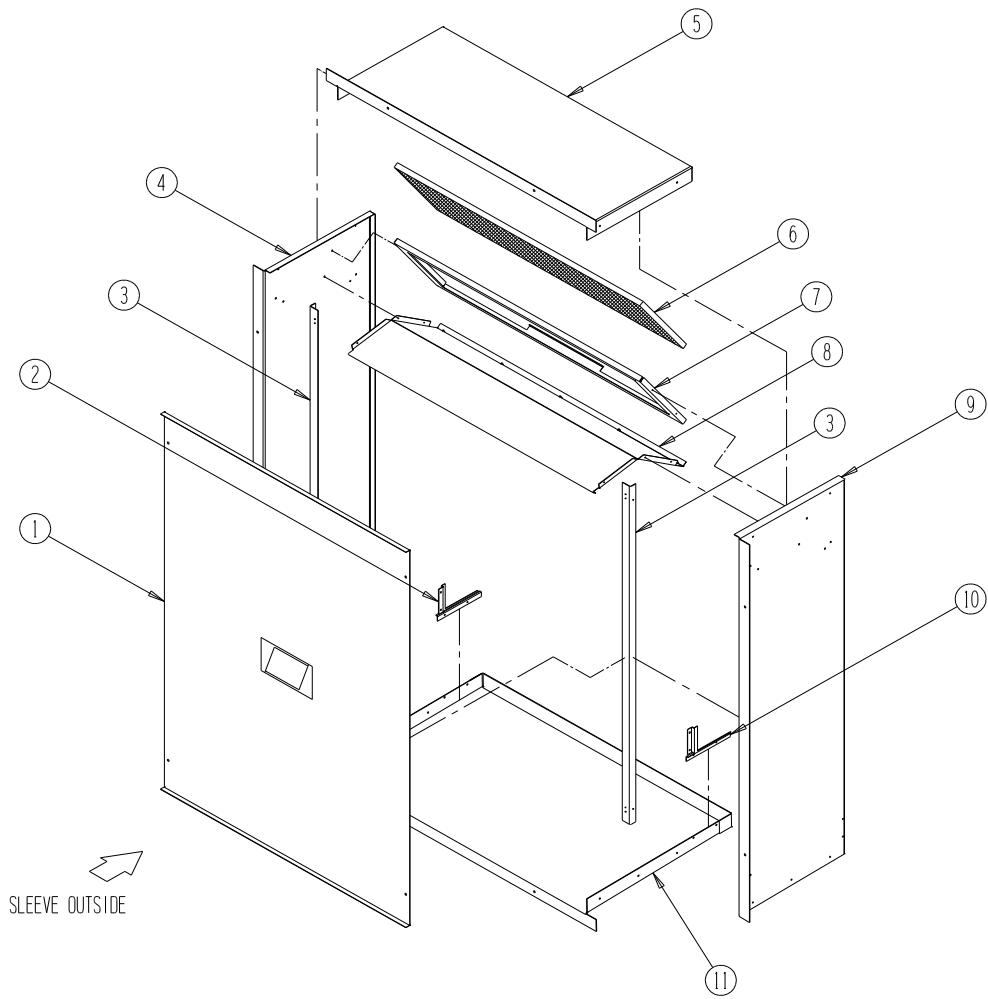

---

SEXP-281



## WALL SLEEVE CABINET COMPONENTS

Drawing No.	Part No.	Description	QWS42A	QWS42A-16	QWS48A	QWS48A-16
1	142-056	Cover	X	X		
1	142-068	Cover			X	X
2	137-450-X	Left Sleeve Corner Fill	X	X	X	X
3	104-988-X	Angle	2	2	2	2
4	111-081-X	Left Side	X		X	
4	111-083-X	Left Side		X		X
5	111-047-X	Top	X			
5	110-050-X	Top		X		
5	110-056-X	Top			X	
5	110-070-X	Top				X
6	7003-044	Mist Eliminator	X	X	X	X
7	131-120-X	Filter Tray	X	X		
7	131-128-X	Filter Tray			X	X
8	121-305-X	Partition	X			
8	121-309-X	Partition		X		
8	121-322-X	Partition			X	
8	121-348-X	Partition				X
9	111-080-X	Right Side	X		X	
9	111-082-X	Right Side		X		X
10	137-449-X	Right Sleeve Corner Fill	X	X		
11	111-046-X	Base	X			
11	111-049-X	Base		X		
11	111-055-X	Base			X	
11	111-071-X	Base				X