REPLACEMENT PARTS MANUAL

Q-TEC SERIES PACKAGED HEAT PUMP

Models:

Q24H2D Q30H2D
Q36H2D Q42H2D
Q48H2D Q60H2D

General Notes

- Revised and/or additional pages may be issued from time to time.
- A complete and current manual consists of pages shown in the following contents section.

Contents

Description	Page
Cabinet Components	
♦ Exploded View	2
♦ Usage List	3
♦ Usage List	4
♦ Usage List	5
♦ Usage List	6
♦ Blank Page	7
Functional Components	
♦ Exploded View	8
♦ Usage List	9
♦ Usage List	10
♦ Usage List	11
Upper Control Panel Components	
♦ Exploded View	12
♦ Usage List	13
♦ Usage List	14
♦ Usage List	15
♦ Usage List	16
♦ Usage List	17
♦ Usage List	18
♦ Blank Page	19
Lower Control Panel Components	
♦ Exploded View	20
♦ Usage List	21
Dehumidification Module Components	
♦ Exploded View	22
♦ Usage List	23
Blower Assembly Components	
♦ Exploded View	24
♦ Usage List	25
Optional Climate Control Components	
♦ Exploded View	26
♦ Usage List	27
Wall Sleeve Cabinet Components	
♦ Exploded View	28
♦ Usage List	29



Bard Manufacturing Company, Inc.
Bryan, Ohio 43506
Since 1914...Moving ahead, just as planned.

Manual: 2110-1509
Supersedes: **NEW**
File: Tab 14
Date: 11-05-13

CABINET COMPONENTS

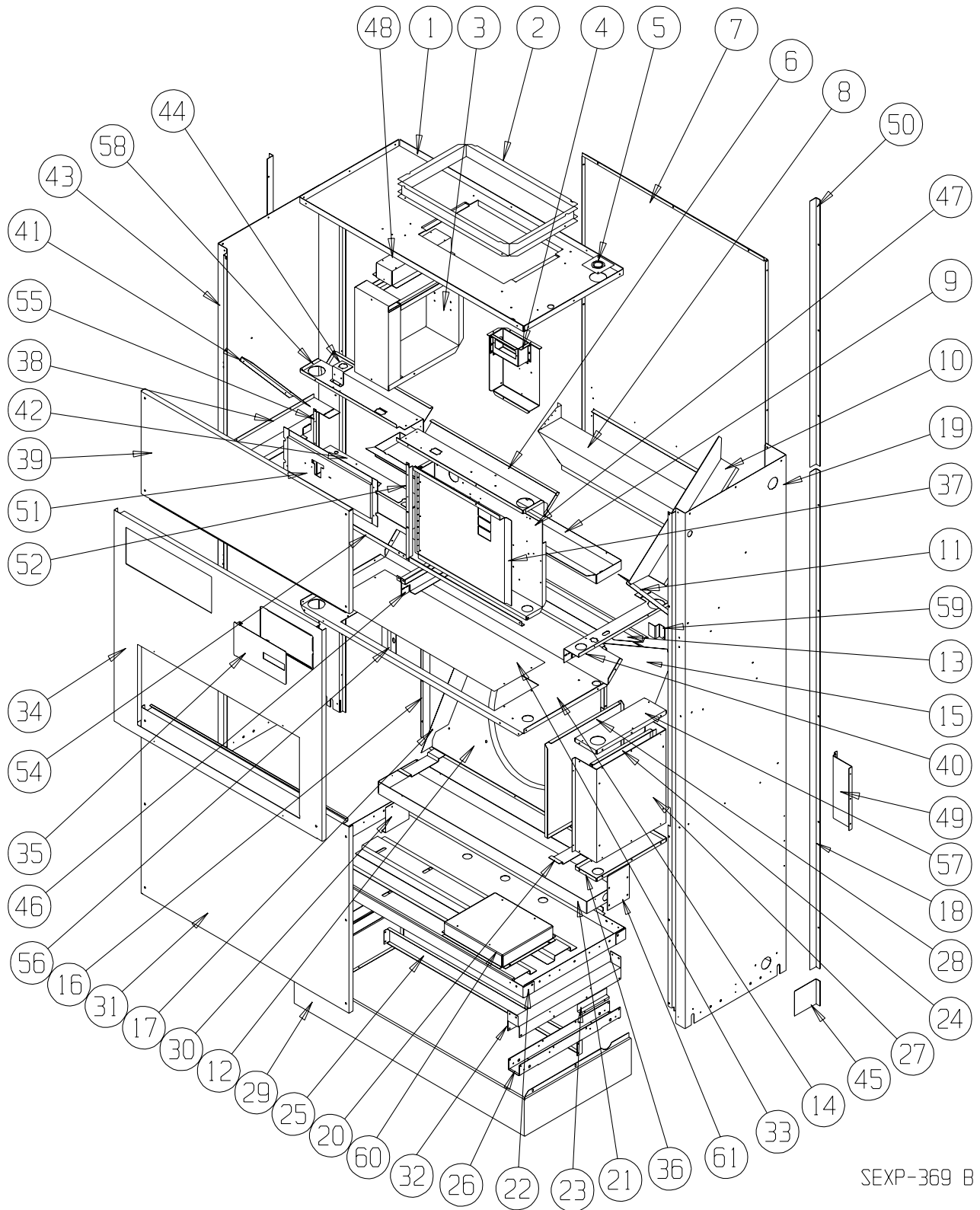

SEXP-369 B

This Exploded View is referenced in Tables on Page 3, 4, 5 & 6

CABINET COMPONENTS

Drawing No.	Part No.	Description	Q24H2DA, B	Q24H2DC	Q30H2DA, B	Q30H2DC	Q36H2DA, B	Q36H2DC	Q42H2DA, B	Q42H2DC
1	506-225	Top Assembly	X	X	X	X	X	X	X	X
2	110-044	Outlet Duct Flange	2	2	2	2	2	2	2	2
3	See Page 12	Heater Package Assembly (Optional)	X	X	X	X	X	X	X	X
4	117-285	Low Voltage Box Assembly (Optional)	X	X	X	X	X	X	X	X
5	136-359	T.K.O. Plate	X	X	X	X	X	X	X	X
6	534-191	Evaporator Coil Shield - Right	X	X	X	X	X	X	X	X
7	508-133	Back Assembly	X	X	X	X	X	X	X	X
8	S538-215	Fresh Air Damper Assembly	X	X	X	X	X	X	X	X
9	S523-104	Evaporator Drain Pan Assembly	X	X	X	X	X	X	X	X
10	134-154	Wire Channel	X	X	X	X	X	X	X	X
11	140X277	Right Evaporator Support	X	X	X	X	X	X	X	X
12	125-032	Fan Shroud Back	X	X	X	X	X	X	X	X
13	142-055	Condenser Coil Fill	X	X	X	X	X	X	X	X
14	520-346	Condenser Partition Assembly	X	X	X	X	X	X	X	X
15	124X043	Fan Shroud Right Side	X	X	X	X	X	X	X	X
16	124Y043	Fan Shroud Left Side	X	X	X	X	X	X	X	X
17	140-229	Condenser Coil Support	2	2	2	2	2	2	2	2
18	S135-177-* ①	Side Trim - Lower	2	2	2	2	2	2	2	2
19	500-392-* ①	Right Side Assembly	X	X	X	X	X	X	X	X
20	140-227	Subcooling Loop Hold Down	3	3	3	3	3	3	3	3
21	123-094	Condenser Drain Pan Assembly	X	X	X	X	X	X	X	X
22	527-309-X	Lower Base Assembly	X	X	X	X	X	X	X	X
23	102-415	Pile Seal Offset	2	2	2	2	2	2	2	2
24	117-240	Lower Control Panel Plate	X	X	X	X	X	X	X	X
25	135-189	Base Shield	X	X	X	X	X	X	X	X
26	140-276	Lower Roller Support	2	2	2	2	2	2	2	2
27	See Page 8	Control Panel Components	X	X	X	X	X	X	X	X
28	133-164	Control Panel Door - Lower	X	X	X	X	X	X	X	X
29	534-155-6	Base Trim Assembly	X	X	X	X	X	X	X	X
30	140-230	Drain Pan Support	X	X	X	X	X	X	X	X
31	552-332-* ①	Condenser Door Assembly	X	X	X	X	X	X	X	X
32	140-280	Upper Roller Support	2	2	2	2	2	2	2	2
33	536-351	Condenser Blank Off Plate	X	X	X	X	X	X	X	X
34	552-330-* ①	Filter Door Assembly	X	X	X	X	X	X	X	X
35	153-336-* ①	Circuit Breaker Door	X	X	X	X	X	X	X	X
36	117-238	Lower Control Panel Bottom	X	X	X	X	X	X	X	X
37	132-173	Rotary Disconnect Door Inner		X		X		X		X
37	132-165	Circuit Breaker Door Inner	X		X		X		X	
38	113-281	Left Filter Bracket	X	X	X	X	X	X	X	X
39	552-331-* ①	Blower Door Assembly	X	X	X	X	X	X	X	X

Continued on Page 4

① Exterior cabinet parts are manufactured with various paint color options. To ensure that you receive the proper paint color, please reference the following codes:

- Beige -X
- Buckeye Gray -4
- Vinyl - Slate Finish -6
- Vinyl - Platinum Finish -7

This Table references Exploded View on Page 2

CABINET COMPONENTS

Drawing No.	Part No.	Description	Q24H2DA, DB	Q24H2DC	Q30H2DA, DB	Q30H2DC	Q36H2DA, DB	Q36H2DC	Q42H2DA, DB	Q42H2DC
<i>Continued from Page 3</i>										
40	113-282	Right Filter Bracket	X	X	X	X	X	X	X	X
41	140Y277	Left Evaporator Support	X	X	X	X	X	X	X	X
42	116-254	Dehum Control Box	X	X	X	X	X	X	X	X
43	500-391-* ①	Left Side Assembly	X	X	X	X	X	X	X	X
44	113-142	Expansion Valve Mounting Plate	X	X	X	X	X	X	X	X
45	135-165-* ①	Base Trim Extension	2	2	2	2	2	2	2	2
46	112X283	Center Right Filter Bracket	X	X	X	X	X	X	X	X
46	112Y283	Center Left Filter Bracket	X	X	X	X	X	X	X	X
47	See Page 12	Pull Disconnect Assembly		X		X		X		X
47	See Page 12	Circuit Breaker Box Assembly	X		X		X		X	
48	112-229	Heatstrip Bracket	X	X	X	X	X	X	X	X
49	112-234	Mounting Bracket	2	2	2	2	2	2	2	2
50	S135-178-* ①	Side Trim - Upper	2	2	2	2	2	2	2	2
51	See Page 26	Thermostat Mounting Plate	X	X	X	X	X	X	X	X
52	104-1096	Left Thermostat Support Angle	X	X	X	X	X	X	X	X
54	104-1097	Front Filter Angle	X	X	X	X	X	X	X	X
55	104-1096	Right Thermostat Support Angle	X	X	X	X	X	X	X	X
56	102-434	Sleeve Offset	X	X	X	X	X	X	X	X
57	117-237	Lower Control Panel Top	X	X	X	X	X	X	X	X
58	534-190	Evaporator Coil Shield - Left	X	X	X	X	X	X	X	X
59	103-443	Door Latch Offset	X	X	X	X	X	X	X	X
60	140-282	Transformer Support		X		X		X		X
NS	132-180	Dehum Control Box Cover	X	X	X	X	X	X	X	X

① Exterior cabinet parts are manufactured with various paint color options. To ensure that you receive the proper paint color, please reference the following codes:

- Beige -X
- Buckeye Gray -4
- Vinyl - Slate Finish -6
- Vinyl - Platinum Finish -7

This Table references Exploded View on Page 2

CABINET COMPONENTS

Drawing No.	Part No.	Description	Q48H2DA, DB	Q60H2DA, DB
			Q48H2DC	Q60H2DC
1	506-226	Top Assembly	X	X
2	110-044	Outlet Duct Flange	2	2
3	See Page 12	Heater Package Assembly (Optional)	X	X
4	117-285	Low Voltage Box Assembly (Optional)	X	X
5	136-359	T.K.O. Plate	X	X
6	534-195	Evaporator Coil Shield - Right	X	X
7	508-149	Back Assembly	X	X
8	S538-215	Fresh Air Damper Assembly	X	X
9	S523-105	Evaporator Drain Pan Assembly	X	X
10	134-154	Wire Channel	X	X
11	140X277	Right Evaporator Support	X	X
12	125-046	Fan Shroud Back	X	X
13	143-066	Condenser Coil Fill	X	X
14	520-347	Condenser Partition Assembly	X	X
15	125-041	Fan Shroud Right Side	X	X
16	125-045	Fan Shroud Left Side	X	X
17	140-229	Condenser Coil Support	2	2
18	S135-177-* ①	Side Trim - Lower	2	2
19	500-392-* ①	Right Side Assembly	X	X
20	140-227	Subcooling Loop Hold Down	3	3
21	123-099	Condenser Drain Pan Assembly	X	X
22	527-294-X	Lower Base Assembly	X	X
23	102-415	Pile Seal Offset	2	2
24	117-240	Lower Control Panel Plate	X	X
25	135-194	Base Shield	X	X
26	140-225	Lower Roller Support	2	2
27	See Page 8	Control Panel Components	X	X
28	133-164	Control Panel Door - Lower	X	X
29	534-174-6	Base Trim Assembly	X	X
31	552-334-* ①	Condenser Door Assembly	X	X
32	140-224-X	Upper Roller Support	2	2
33	536-351	Condenser Blank Off Plate	X	X
34	552-335-* ①	Filter Door Assembly	X	X
35	152-336-* ①	Circuit Breaker Door	X	X
36	117-238	Lower Control Panel Bottom	X	X
37	132-173	Rotary Disconnect Door Inner		X
37	132-165	Circuit Breaker Door Inner	X	
38	113-281	Left Filter Bracket	X	X
39	552-333-* ①	Blower Door Assembly	X	X

Continued on Page 6

① Exterior cabinet parts are manufactured with various paint color options. To ensure that you receive the proper paint color, please reference the following codes:

- Beige -X
- Buckeye Gray -4
- Vinyl - Slate Finish -6
- Vinyl - Platinum Finish -7

This Table references Exploded View on Page 2

CABINET COMPONENTS

Drawing No.	Part No.	Description	Q48H2DA, DB Q60H2DA, DB		Q48H2DC Q60H2DC	
<i>Continued from Page 5</i>						
40	113-286	Right Filter Bracket	X		X	
41	140Y277	Left Evaporator Support	X		X	
42	116-254	Dehum Control Box	X		X	
43	500-393-* ①	Left Side Assembly	X		X	
44	113-142	Expansion Valve Mounting Plate	X		X	
45	134-165-* ①	Base Trim Extension	2		2	
46	112X283	Center Right Filter Bracket	X		X	
46	112Y283	Center Left Filter Bracket	X		X	
47	See Page 12	Pull Disconnect Assembly			X	
47	See Page 12	Circuit Breaker Box Assembly	X			
48	112-229	Heatstrip Bracket	X		X	
49	112-245	Right Mounting Bracket	X		X	
49	112-246	Left Mounting Bracket	X		X	
50	S135-178-* ①	Side Trim - Upper	2		2	
51	See Page 26	Thermostat Mounting Plate	X		X	
52	104-1096	Left Thermostat Support Angle	X		X	
54	104-1101	Front Filter Angle	X		X	
55	104-1096	Right Thermostat Support Angle	X		X	
56	102-434	Sleeve Offset	X		X	
57	117-237	Lower Control Panel Top	X		X	
58	534-190	Evaporator Coil Shield - Left	X		X	
59	103-443	Door Latch Offset	X		X	
60	140-282	Transformer Support			X	
61	112-372	Motor Control Bracket (Q60H*D only)	X		X	
NS	132-180	Dehum Control Box Cover	X		X	

① Exterior cabinet parts are manufactured with various paint color options. To ensure that you receive the proper paint color, please reference the following codes:

Beige -X
 Buckeye Gray -4
 Vinyl - Slate Finish -6
 Vinyl - Platinum Finish -7

This Table references Exploded View on Page 2

This page intentionally left blank.

FUNCTIONAL COMPONENTS

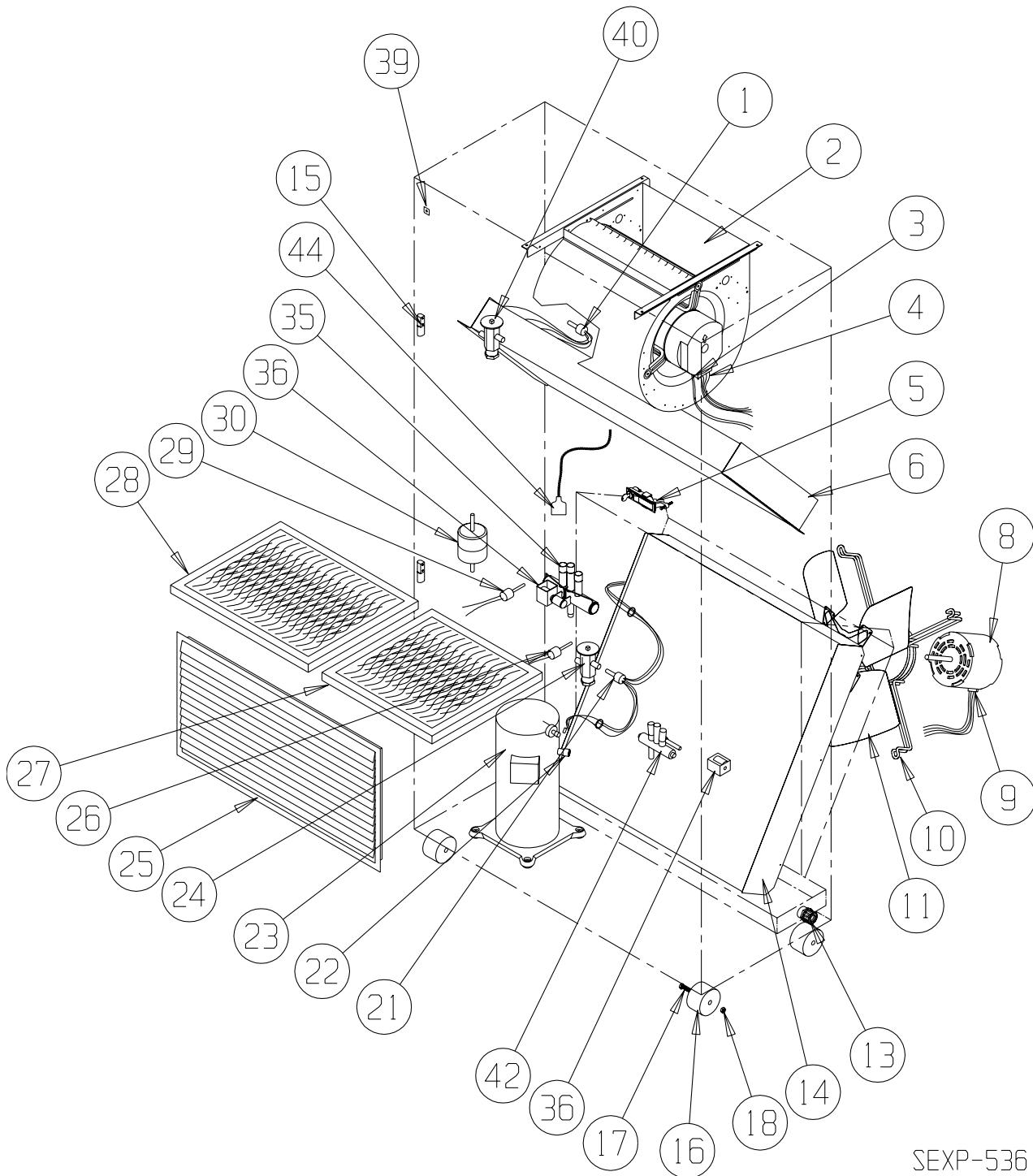

SEXP-536

This Exploded View is referenced in Tables on pages 9, 10 & 11

FUNCTIONAL COMPONENTS

Drawing No.	Part No.	Description	Q24H2DA	Q24H2DB	Q24H2DC	Q30H2DA	Q30H2DB	Q30H2DC	Q36H2DA	Q36H2DB	Q36H2DC	Q42H2DA	Q42H2DB	Q42H2DC
1	5625-015	Distributor Cooling	X	X	X	X	X	X						
1	5625-020	Distributor Cooling							X	X	X	X	X	X
2	S900-225-001	Blower Assembly	X	X	X									
2	S900-225-002	Blower Assembly				X	X	X						
2	S900-225-004	Blower Assembly							X	X	X	X	X	X
3	3000-1145	Wire Harness High Voltage			X			X			X			X
3	3000-1046	Wire Harness High Voltage	X	X		X	X		X	X		X	X	
4	3000-1292	Wire Harness Low Voltage	X	X	X	X	X	X	X	X	X	X	X	X
5	1171-049	Keylatch/Circuit Breaker Door	X	X	X	X	X	X	X	X				
6	917-0039BX	Evaporator Coil Assembly	X	X	X									
6	917-0104BX	Evaporator Coil Assembly				X	X	X						
6	917-0040BX	Evaporator Coil Assembly							X	X	X	X	X	X
8	8103-037	Motor	X	X		X	X							
8	8103-038	Motor			X			X						
8	8105-051	Motor							X	X		X	X	
8	8105-052	Motor									X			X
9	3000-1141	Wire Harness	X	X	X	X	X	X	X	X	X	X	X	X
10	8200-001	Motor Mount	X	X	X	X	X	X	X	X	X	X	X	X
11	5151-050	Fan Blade	X	X	X	X	X	X						
11	5151-055	Fan Blade							X	X	X	X	X	X
13	6094-003	Drain Fitting	1	1	1	1	1	1	1	1	1	1	1	1
14	5051-095BX	Condenser Coil	X	X	X	X	X	X						
14	5051-096BX	Condenser Coil							X	X	X	X	X	X
15	5400-005	Hinge	2	2	2	2	2	2	2	2	2	2	2	2
16	1171-035	Wheel	4	4	4	4	4	4	4	4	4	4	4	4
17	1012-129	Bolt - Shoulder	4	4	4	4	4	4	4	4	4	4	4	4
18	1012-224	Nut - Locking	4	4	4	4	4	4	4	4	4	4	4	4
21	5625-008	Distributor - Heating	X	X	X	X	X	X						
21	5625-010	Distributor - Heating							X	X	X	X	X	X
22	8620-224	Defrost Sensor	X	X	X	X	X	X	X	X	X	X	X	X
23	8000-314	Compressor	X											
23	8000-315	Compressor		X										
23	8000-316	Compressor			X									
23	8000-298	Compressor				X								
23	8000-299	Compressor					X							
23	8000-300	Compressor						X						
23	8000-309	Compressor							X					
23	8000-310	Compressor								X				
23	8000-311	Compressor									X			
23	8000-318	Compressor										X		
23	8000-319	Compressor											X	
23	8000-320	Compressor												X
24	5651-191	TXV Heating	X	X	X									
24	5651-177	TXV Heating				X	X	X						
24	5651-178	TXV Heating							X	X	X	X	X	X
25	7051-034	Return Air Grille	X	X	X	X	X	X	X	X	X	X	X	X
25	7051-061	Return Air Grille (Vinyl)	X	X	X	X	X	X	X	X	X	X	X	X
26	1804-0462	High Pressure Control	X	X	X	X	X	X	X	X	X	X	X	X
27	7004-009	Air Filter	X	X	X	X	X	X	X	X	X	X	X	X
27	7004-032	Filter 2" Fiberglass (Optional)	X	X	X	X	X	X	X	X	X	X	X	X
27	7004-034	Filter 2" Pleated (Optional)	X	X	X	X	X	X	X	X	X	X	X	X
28	7004-010	Air Filter	X	X	X	X	X	X	X	X	X	X	X	X
28	7004-033	Filter 2" Fiberglass (Optional)	X	X	X	X	X	X	X	X	X	X	X	X
28	7004-035	Filter 2" Pleated (Optional)	X	X	X	X	X	X	X	X	X	X	X	X

Continued on Page 10

This Table references Exploded View on Page 8

FUNCTIONAL COMPONENTS

Drawing No.	Part No.	Description	Q24H2DA	Q24H2DB	Q24H2DC	Q30H2DA	Q30H2DB	Q30H2DC	Q36H2DA	Q36H2DB	Q36H2DC	Q42H2DA	Q42H2DB	Q42H2DC
<i>Continued from Page 9</i>														
29	1804-0107	Low Pressure Control	X	X	X	X	X	X	X	X	X	X	X	X
30	5201-009	Filter/Drier	X	X	X	X	X	X						
30	5201-010	Filter/Drier							X	X	X	X	X	X
35	5650-038	Reversing Valve with Solenoid	X	X	X									
35	5650-039	Reversing Valve with Solenoid				X	X	X						
35	5650-040	Reversing Valve with Solenoid							X	X	X	X	X	X
36	5650-042	Rev. Valve Solenoid, Red Casing (Ranco)	X	X	X	X	X	X	X	X	X	X	X	X
36	5650-043	Rev. Valve Solenoid, Blk Casing (Wilspec)	X	X	X	X	X	X	X	X	X	X	X	X
36	5650-046	Rev. Valve Solenoid, Blk Casing (San Hua)	X	X	X	X	X	X	X	X	X	X	X	X
39	1012-315	"U" Clip Fastener	10	10	10	10	10	10	10	10	10	10	10	10
40	5651-191	TXV Cooling	X	X	X									
40	5651-177	TXV Cooling				X	X	X	X	X				
40	5651-178	TXV Cooling										X	X	X
42	5650-045	Three Way Valve with Solenoid	X	X	X	X	X	X	X	X	X	X	X	X
43	5650-042	Rev. Valve Solenoid, Red Casing (Ranco)	X	X	X	X	X	X	X	X	X	X	X	X
43	5650-043	Rev. Valve Solenoid, Blk Casing (Wilspec)	X	X	X	X	X	X	X	X	X	X	X	X
43	5650-046	Rev. Valve Solenoid, Blk Casing (San Hua)	X	X	X	X	X	X	X	X	X	X	X	X
44	5650-037	Molded Plug 36" Lead	2	2	2	2	2	2	2	2	2	2	2	2
NS	CMA-28	Low Ambient Control	X	X	X	X	X	X	X	X	X	X	X	X
NS	4100-122	Unit Wiring Diagram	X			X			X			X		
NS	4100-222	Unit Wiring Diagram		X			X			X			X	
NS	4100-322	Unit Wiring Diagram			X			X			X			X
NS	800-0396	Drain Back Tube Assembly	X	X	X	X	X	X	X	X	X	X	X	X
NS	8002-012	Sound Cover	X	X	X	X	X	X	X	X	X	X	X	X
NS	3000-1290	Compressor Wire Harness	X			X			X			X		
NS	3000-1291	Compressor Wire Harness		X	X		X	X		X	X		X	X

NS = Not Shown

These Tables reference Exploded View on Page 8

FUNCTIONAL COMPONENTS

Drawing No.	Part No.	Description	Q48H2DA	Q48H2DB	Q48H2DC	Q60H2DA	Q60H2DB	Q60H2DC
1	5625-022	Cooling Distributor	X	X	X			
1	5625-019	Cooling Distributor				X	X	X
2	S900-225-005	Blower Assembly	X	X	X			
2	S900-254-001	Blower Assembly				X	X	X
3	3000-1145	Wire Harness High Voltage			X			X
3	3000-1046	Wire Harness High Voltage	X	X		X	X	
4	3000-1292	Wire Harness Low Voltage	X	X	X	X	X	X
5	1171-049	Keylatch/Circuit Breaker Door	X	X	X	X	X	X
6	917-0041BX	Evaporator Coil	X	X	X			
6	917-0069BX	Evaporator Coil				X	X	X
8	8105-051	Motor	X	X				
8	8105-052	Motor			X			
8	8106-047	ECM Motor				X	X	X
9	3000-1141	Wire Harness	X	X	X	X	X	X
10	8200-001	Motor Mount	X	X	X	X	X	X
11	5151-055	Fan Blade	X	X	X	X	X	X
13	6094-003	Drain Fitting	2	2	2	2	2	2
14	5051-162BX	Condenser Coil 28 x 36"	X	X	X	X	X	X
14	5051-161BX	Condenser Coil 8 x 36"				X	X	X
15	5400-005	Hinge	2	2	2	2	2	2
16	1171-035	Wheel	4	4	4	4	4	4
17	1012-129	Bolt - Shoulder	4	4	4	4	4	4
18	1012-224	Nut - Locking	4	4	4	4	4	4
21	5625-024	Distributor - Heating	X	X	X	X	X	X
22	8620-224	Defrost Sensor	X	X	X	X	X	X
23	8000-343	Compressor	X					
23	8000-344	Compressor		X				
23	8000-345	Compressor			X			
23	8000-324	Compressor				X		
23	8000-325	Compressor					X	
23	8000-326	Compressor						X
24	5651-178	TXV Heating	X	X	X			
24	5651-184	TXV Heating				X	X	X
25	7051-039	Return Air Grille	X	X	X	X	X	X
25	7051-063	Return Air Grille (Vinyl)	X	X	X	X	X	X
26	1804-0462	High Pressure Control	X	X	X	X	X	X
27	7004-009	Air Filter	X	X	X	X	X	X
27	7004-032	Filter 2" Fiberglass (Optional)	X	X	X	X	X	X
27	7004-034	Filter 2" Pleated (Optional)	X	X	X	X	X	X
28	7004-011	Air Filter	X	X	X	X	X	X
28	7004-036	Filter 2" Fiberglass (Optional)	X	X	X	X	X	X
28	7004-025	Filter 2" Pleated (Optional)	X	X	X	X	X	X
29	1804-0107	Low Pressure Control	X	X	X	X	X	X
30	5201-010	Filter/Drier	X	X	X	X	X	X
35	5650-040	Reversing Valve	X	X	X	X	X	X
36	5650-042	Rev. Valve Solenoid, Red Casing (Ranco)	X	X	X	X	X	X
36	5650-043	Rev. Valve Solenoid, Black Casing (Wilspec)	X	X	X	X	X	X
36	5650-046	Rev. Valve Solenoid, Black Casing (San Hua)	X	X	X	X	X	X
39	1012-315	"U" Clip Fastener	10	10	10	10	10	10
40	5651-178	TXV Cooling	X	X	X			
40	5651-182	TXV Cooling				X	X	X
42	5650-045	Three Way Valve with Solenoid	X	X	X	X	X	X
43	5650-042	Rev. Valve Solenoid, Red Casing (Ranco)	X	X	X	X	X	X
43	5650-043	Rev. Valve Solenoid, Black Casing (Wilspec)	X	X	X	X	X	X
43	5650-046	Rev. Valve Solenoid, Black Casing (San Hua)	X	X	X	X	X	X
44	5650-037	Molded Plug 36" Lead	X	X	X	X	X	X
NS	CMA-28	Low Ambient Control	X	X	X	X	X	X
NS	4100-122	Unit Wiring Diagram	X					
NS	4100-222	Unit Wiring Diagram		X				
NS	4100-322	Unit Wiring Diagram			X			
NS	4100-124	Unit Wiring Diagram				X		
NS	4100-224	Unit Wiring Diagram					X	
NS	4100-324	Unit Wiring Diagram						X
NS	5202-026	Suction Accumulator				X	X	X
NS	8002-012	Sound Cover	X	X	X	X	X	X
NS	3000-1290	Compressor Wire Harness	X			X		
NS	3000-1291	Compressor Wire Harness		X	X		X	X

NS = Not Shown

These Tables reference Exploded View on Page 8

UPPER CONTROL PANEL COMPONENTS

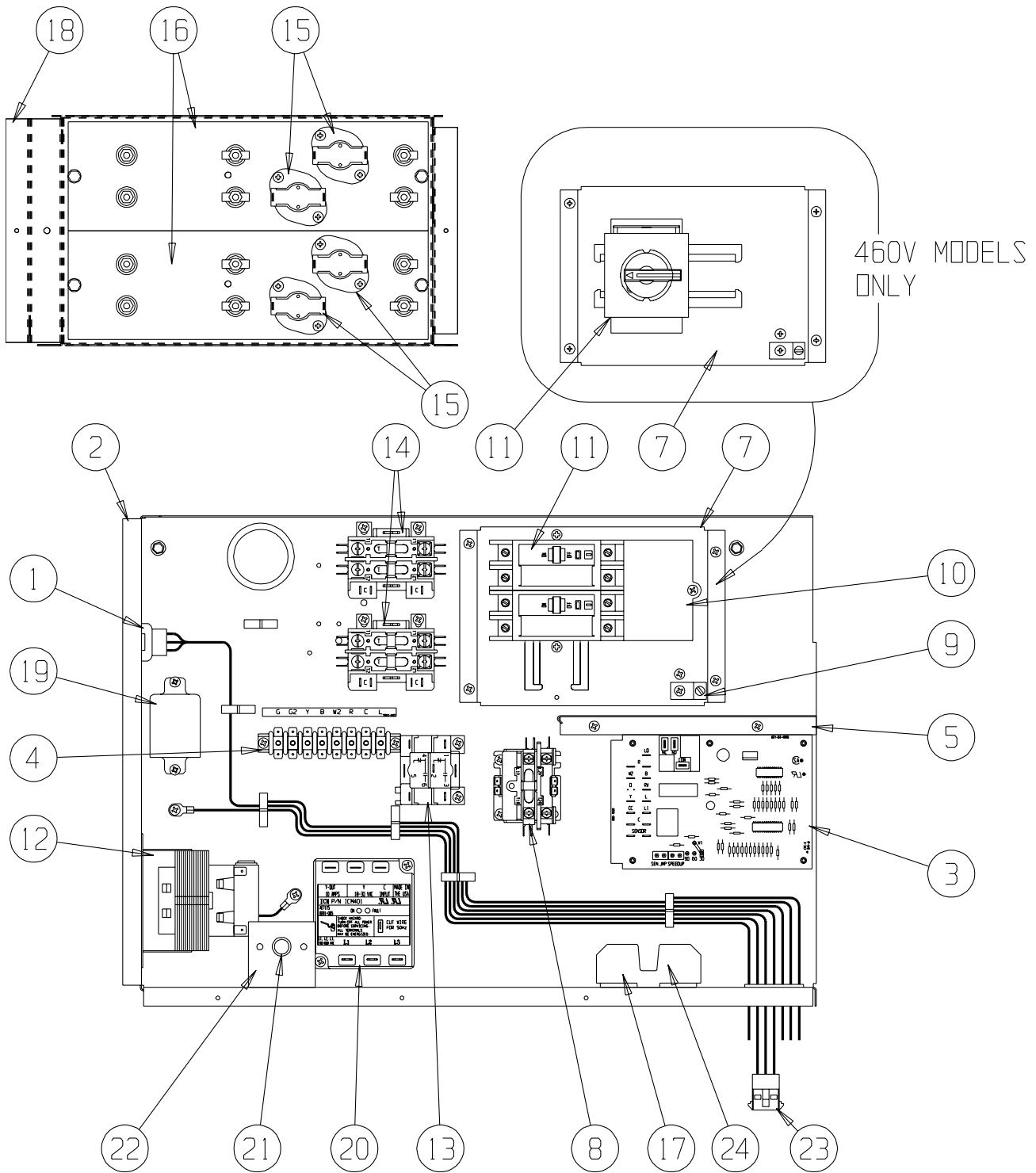

SEXP-373 B

This Exploded View is referenced in Tables on pages 13 — 18

UPPER CONTROL PANEL COMPONENTS

Drawing No.	Part No.	Description	Q24H2DA0Z	Q30H2DA0Z	Q36H2DA0Z	Q42H2DA0Z	Q48H2DA0Z	Q60H2DA0Z	Q24H2DA05	Q30H2DA05	Q36H2DA05	Q42H2DA05	Q48H2DA05	Q60H2DA05
1	3000-1293	Wire Set PL2	X	X	X	X	X	X	X	X	X	X	X	X
2	117-241	Control Panel	X	X	X	X	X	X	X	X	X	X	X	X
3	8620-223	Heat Pump Control	X	X	X	X	X	X	X	X	X	X	X	X
4	8607-022	Terminal Block	X	X	X	X	X	X	X	X	X	X	X	X
5	117-242	Box Partition	X	X	X	X	X	X	X	X	X	X	X	X
7	126-267	Circuit Breaker Base	X	X	X	X	X	X	X	X	X	X	X	X
8	8401-007	Contactor	X	X	X				X	X				
8	8401-016	Contactor					X	X					X	X
9	8611-006	Ground Lug	X	X	X	X	X	X	X	X	X	X	X	X
10	8615-047	Jumper Bar Base											X	X
11	8615-036	Circuit Breaker 2 Pole 25A Ckt B											X	X
11	8615-037	Circuit Breaker 2 Pole 30A Ckt A	X											
11	8615-039	Circuit Breaker 2 Pole 45A Ckt A		X										
11	8615-040	Circuit Breaker 2 Pole 50A Ckt A			X	X			X				X	
11	8615-041	Circuit Breaker 2 Pole 60A Ckt A						X			X			X
12	8407-048	Transformer	X	X	X	X	X	X	X	X	X	X	X	X
14	8401-006	Contactor 2 Pole 20A							X	X	X	X	X	X
15	8402-100	Limits							1		1		1	
15	8402-131	Limits												X
16	8601-103	Heat Strip 5 kW							X	X	X	X	X	X
18	116-191	Heat Strip Wrapper							X	X	X	X	X	X
19	8201-048	Relay							X	X	X	X	X	X
21	8611-094	Indicator Light	X	X	X	X	X	X	X	X	X	X	X	X
22	112-225	Bracket	X	X	X	X	X	X	X	X	X	X	X	X
23	3000-1148	Wire Set PL3	X	X	X	X	X	X	X	X	X	X	X	X
NS	132-145	Heat Strip Cover							X	X	X	X	X	X
NS	4101-100	Breaker Wiring Diagram	X	X	X	X	X							
NS	4101-101	Heat Kit Wiring Diagram							X	X				
NS	4101-106	Heat Kit Wiring Diagram											X	X

NS = Not Shown

This Table references Exploded View on Page 12

UPPER CONTROL PANEL COMPONENTS

Drawing No.	Part No.	Description	Q24H2DA10	Q30H2DA10	Q36H2DA10	Q42H2DA10	Q48H2DA10	Q60H2DA10	Q36H2DA15	Q42H2DA15	Q48H2DA15	Q60H2DA15
1	3000-1293	Wire Set PL2	X	X	X	X	X	X	X	X	X	X
2	117-241	Control Panel	X	X	X	X	X	X	X	X	X	X
3	8620-223	Heat Pump Control	X	X	X	X	X	X	X	X	X	X
4	8607-022	Terminal Block	X	X	X	X	X	X	X	X	X	X
5	117-242	Box Partition	X	X	X	X	X	X	X	X	X	X
7	126-267	Circuit Breaker Base	X	X	X	X	X	X	X	X	X	X
8	8401-007	Contactor	X	X				X				
8	8401-016	Contactor					X	X			X	X
9	8611-006	Ground Lug	X	X	X	X	X	X	X	X	X	X
10	8615-047	Jumper Bar Base	X	X	X	X	X	X	X	X	X	X
11	8615-037	Circuit Breaker 2 Pole 30A Ckt A	X									
11	8615-055	Circuit Breaker 2 Pole 40A Ckt A		X					X	X		
11	8615-040	Circuit Breaker 2 Pole 50A Ckt A			X							
11	8615-040	Circuit Breaker 2 Pole 50A Ckt B	X	X	X	X	X	X	X	X	X	X
11	8615-041	Circuit Breaker 2 Pole 60A Ckt A					X					X
12	8407-048	Transformer	X	X	X	X	X	X	X	X	X	X
14	8401-006	Contactor 2 Pole 20A	X	X	X	X	X	2	2	2	2	2
15	8402-100	Limits	2	2	2			3	3			
15	8402-131	Limits					2					3
16	8601-103	Heat Strip 5 KW						X	X	X	X	X
16	8601-104	Heat Strip 10 KW	X	X	X	X	X	X	X	X	X	X
18	116-191	Heat Strip Wrapper	X	X	X	X	X	X	X	X	X	X
19	8201-048	Relay	X	X	X	X	X	X	X	X	X	X
21	8611-094	Indicator Light	X	X	X	X	X	X	X	X	X	X
22	112-225	Bracket	X	X	X	X	X	X	X	X	X	X
23	3000-1148	Wire Set PL3	X	X	X	X	X	X	X	X	X	X
NS	132-145	Heat Strip Cover	X	X	X	X	X	X	X	X	X	X
NS	4101-102	Heat Kit Wiring Diagram	X	X	X	X						
NS	4101-103	Heat Kit Wiring Diagram						X	X	X		

NS = Not Shown

This Table references Exploded View on Page 12

UPPER CONTROL PANEL COMPONENTS

Drawing No.	Part No.	Description	Q24H2DB0Z	Q30H2DB0Z	Q36H2DB0Z	Q42H2DB0Z	Q48H2DB0Z	Q60H2DB0Z	Q24H2DB06	Q30H2DB06	Q36H2DB06	Q42H2DB06	Q48H2DB06
1	3000-1293	Wire Set PL2	X	X	X	X	X	X	X	X	X	X	X
2	117-241	Control Panel	X	X	X	X	X	X	X	X	X	X	X
3	8620-223	Heat Pump Control	X	X	X	X	X	X	X	X	X	X	X
4	8607-022	Terminal Block	X	X	X	X	X	X	X	X	X	X	X
5	117-242	Box Partition	X	X	X	X	X	X	X	X	X	X	X
7	126-267	Circuit Breaker Base	X	X	X	X	X	X	X	X	X	X	X
8	8401-002	Contactor	X	X	X	X	X	X	X	X	X	X	X
9	8611-006	Ground Lug	X	X	X	X	X	X	X	X	X	X	X
11	8615-054	Circuit Breaker 3 Pole 20A	X										
11	8615-051	Circuit Breaker 3 Pole 25A		X									
11	8615-052	Circuit Breaker 3 Pole 30A			X								
11	8615-042	Circuit Breaker 3 Pole 35A				X			X				
11	8615-043	Circuit Breaker 3 Pole 40A								X			
11	8615-044	Circuit Breaker 3 Pole 45A						X				X	
12	8407-048	Transformer	X	X	X	X	X	X	X	X	X	X	X
14	8401-006	Contactor 2 Pole 20A							X	X	X	X	X
15	8402-100	Limits							2	2	2	2	2
16	8601-105	Heat Strip 6 KW							X	X	X	X	X
18	116-191	Heat Strip Wrapper							X	X	X	X	X
19	8201-048	Relay							X	X	X	X	X
20	8201-126	3-Phase Line Monitor 50/60 Hz	X	X	X	X	X	X	X	X	X	X	X
21	8611-094	Indicator Light	X	X	X	X	X	X	X	X	X	X	X
22	112-225	Bracket	X	X	X	X	X	X	X	X	X	X	X
23	3000-1148	Wire Set PL3	X	X	X	X	X	X	X	X	X	X	X
NS	132-145	Heat Strip Cover							X	X	X	X	X
NS	4101-200	Breaker Wiring Diagram	X	X	X	X	X	X					
NS	4101-201	Heat Kit Wiring Diagram							X	X	X	X	X

NS = Not Shown

This Table references Exploded View on Page 12

UPPER CONTROL PANEL COMPONENTS

Drawing No.	Part No.	Description	Q24H2DB09	Q30H2DB09	Q36H2DB09	Q42H2DB09	Q48H2DB09	Q60H2DB09	Q30H2DB12	Q36H2DB15	Q42H2DB15	Q48H2DB15	Q60H2DB15
1	3000-1293	Wire Set PL2	X	X	X	X	X	X	X	X	X	X	X
2	117-241	Control Panel	X	X	X	X	X	X	X	X	X	X	X
3	8620-223	Heat Pump Control	X	X	X	X	X	X	X	X	X	X	X
4	8607-022	Terminal Block	X	X	X	X	X	X	X	X	X	X	X
5	117-242	Box Partition	X	X	X	X	X	X	X	X	X	X	X
7	126-267	Circuit Breaker Base	X	X	X	X	X	X	X	X	X	X	X
8	8401-002	Contactor	X	X	X	X	X	X	X	X	X	X	X
9	8611-006	Ground Lug	X	X	X	X	X	X	X	X	X	X	X
11	8615-044	Circuit Breaker 3 Pole 45A	X										
11	8615-045	Circuit Breaker 3 Pole 50A		X									
11	8615-046	Circuit Breaker 3 Pole 60A			X	X	X	X	X	X	X	X	X
12	8407-048	Transformer	X	X	X	X	X	X	X	X	X	X	X
14	8401-006	Contactor 2 Pole 20A	X	X	X	X	X	X	X	2	2	2	X
15	8402-100	Limits	2	2	2				4	4			
15	8402-131	Limits					2						4
16	8601-105	Heat Strip 6 KW							2	X	X	X	X
16	8604-106	Heat Strip 9 KW	X	X	X	X	X			X	X	X	X
18	116-191	Heat Strip Wrapper	X	X	X	X	X	X	X	X	X	X	X
19	8201-048	Relay	X	X	X	X	X	X	X	X	X	X	X
20	8201-126	3-Phase Line Monitor 50/60 Hz	X	X	X	X	X	X	X	X	X	X	X
21	8611-094	Indicator Light	X	X	X	X	X	X	X	X	X	X	X
22	112-225	Bracket	X	X	X	X	X	X	X	X	X	X	X
23	3000-1148	Wire Set PL3	X	X	X	X	X	X	X	X	X	X	X
NS	132-145	Heat Strip Cover	X	X	X	X	X	X	X	X	X	X	X
NS	4101-201	Heat Kit Wiring Diagram	X	X	X	X	X						
NS	4101-202	Heat Kit Wiring Diagram								X	X		
NS	4101-203	Heat Kit Wiring Diagram						X					

NS = Not Shown

This Table references Exploded View on Page 12

UPPER CONTROL PANEL COMPONENTS

Drawing No.	Part No.	Description	Q24H2DC0Z	Q30H2DC0Z	Q36H2DC0Z	Q42H2DC0Z	Q48H2DC0Z	Q60H2DC0Z	Q24H2DC06	Q30H2DC06	Q36H2DC06	Q42H2DC06	Q48H2DC06
1	3000-1293	Wire Set PL2	X					X			X		
2	117-241	Control Panel	X					X			X		
3	8620-223	Heat Pump Control	X					X			X		
4	8607-022	Terminal Block	X					X			X		
5	117-242	Box Partition	X					X			X		
7	126-323	Rotary Disconnect Base	X					X			X		
8	8401-002	Contactors	X					X			X		
9	8611-006	Ground Lug	X					X			X		
11	8615-068	Rotary Disconnect	X					X			X		
12	8407-050	Transformer	X					X			X		
13	8201-032	Relay OMR	X					X			X		
14	8401-002	Contactors 3 Pole 25A	X					X			X		
15	8402-100	Limits										2	
16	8604-107	Heat Strip 6 KW 480V										X	
17	8614-041	Fuse Holder	X					X			X		
18	116-191	Heat Strip Wrapper										X	
19	8201-048	Relay										X	
20	8201-126	3-Phase Line Monitor 50/60 Hz	X					X			X		
21	8611-094	Indicator Light	X					X			X		
22	112-225	Bracket	X					X			X		
23	3000-1148	Wire Set PL3	X					X			X		
NS	8407-052	Transformer Stepdown 1.0 KVA	X									X	
NS	8407-053	Transformer Stepdown 1.5 KVA	X					X				X	
NS	8407-054	Transformer Stepdown 2.0 KVA						X					
NS	8614-046	Fuses Class CC 5.0A ①		2								2	
NS	8614-047	Fuses Class CC 3.2A ②		2				2				2	
NS	8614-042	Fuses Class CC 7.0A ③						2					
NS	132-145	Heat Strip Cover	X					X			X		
NS	8615-071	Pull Disconnect Handle	X					X			X		
NS	4101-300	Heat Kit Wiring Diagram	X					X					
NS	4101-301	Heat Kit Wiring Diagram										X	

NS = Not Shown

① 5.0 Amp fuses used with 1.5 KVA transformer.

② 3.2 Amp fuses used with 1 KVA transformer.

③ 7.0 Amp fuses used with 2 KVA transformer

This Table references Exploded View on Page 12

UPPER CONTROL PANEL COMPONENTS

Drawing No.	Part No.	Description	Q24H2DC09	Q30H2DC09	Q36H2DC09	Q42H2DC09	Q48H2DC09	Q60H2DC09	Q30H2DC12	Q36H2DC15	Q42H2DC15	Q48H2DC15	Q60H2DC15
1	3000-1293	Wire Set PL2	X					X	X	X	X	X	X
2	117-241	Control Panel	X					X	X	X	X	X	X
3	8620-223	Heat Pump Control	X					X	X	X	X	X	X
4	8607-022	Terminal Block	X					X	X	X	X	X	X
5	117-242	Box Partition	X					X	X	X	X	X	X
7	126-323	Rotary Disconnect Base	X					X	X	X	X	X	X
8	8401-002	Contactors	X					X	X	X	X	X	X
9	8611-006	Ground Lug	X					X	X	X	X	X	X
11	8615-068	Rotary Disconnect	X					X	X	X	X	X	X
12	8407-050	Transformer	X					X	X	X	X	X	X
13	8201-032	Relay OMR	X					X	X	X	X	X	X
14	8401-002	Contactors 3 Pole 25A	X					X	X		2		X
15	8402-100	Limits	2						4		4		
15	8402-131	Limits						2					4
16	8604-107	Heat Strip 6 KW 480V							2		X		X
16	8604-108	Heat Strip 9 KW 480V	X					X					
17	8614-041	Fuse Holder	X					X	X	X	X	X	X
18	116-191	Heat Strip Wrapper	X					X	X	X	X	X	X
19	8201-048	Relay	X					X	X	X	X	X	X
20	8201-085	Phase Monitor	X					X	X	X	X	X	X
21	8611-094	Indicator Light	X					X	X	X	X	X	X
22	112-225	Bracket	X					X	X	X	X	X	X
23	3000-1148	Wire Set PL3	X					X	X	X	X	X	X
NS	8407-052	Transformer Stepdown 1.0 KVA	X					X	X	X	X	X	X
NS	8407-053	Transformer Stepdown 1.5 KVA	X					X	X	X	X	X	X
NS	8407-054	Transformer Stepdown 2.0 KVA	X					X	X	X	X	X	X
NS	8614-046	Fuses Class CC 5.0A ①	2					2	2		2		2
NS	8614-047	Fuses Class CC 3.2A ②	2						2		2		
NS	8614-042	Fuses Class CC 7.0A ③						2					2
NS	132-145	Heat Strip Cover	X					X	X	X	X	X	X
NS	8615-071	Rotary Disconnect Handle	X					X	X	X	X	X	X
NS	4101-301	Heat Kit Wiring Diagram	X					X					
NS	4101-302	Heat Kit Wiring Diagram									X		X
NS	4101-303	Heat Kit Wiring Diagram							X				

NS = Not Shown

This Table references Exploded View on Page 12

This page intentionally left blank.

LOWER CONTROL PANEL COMPONENTS

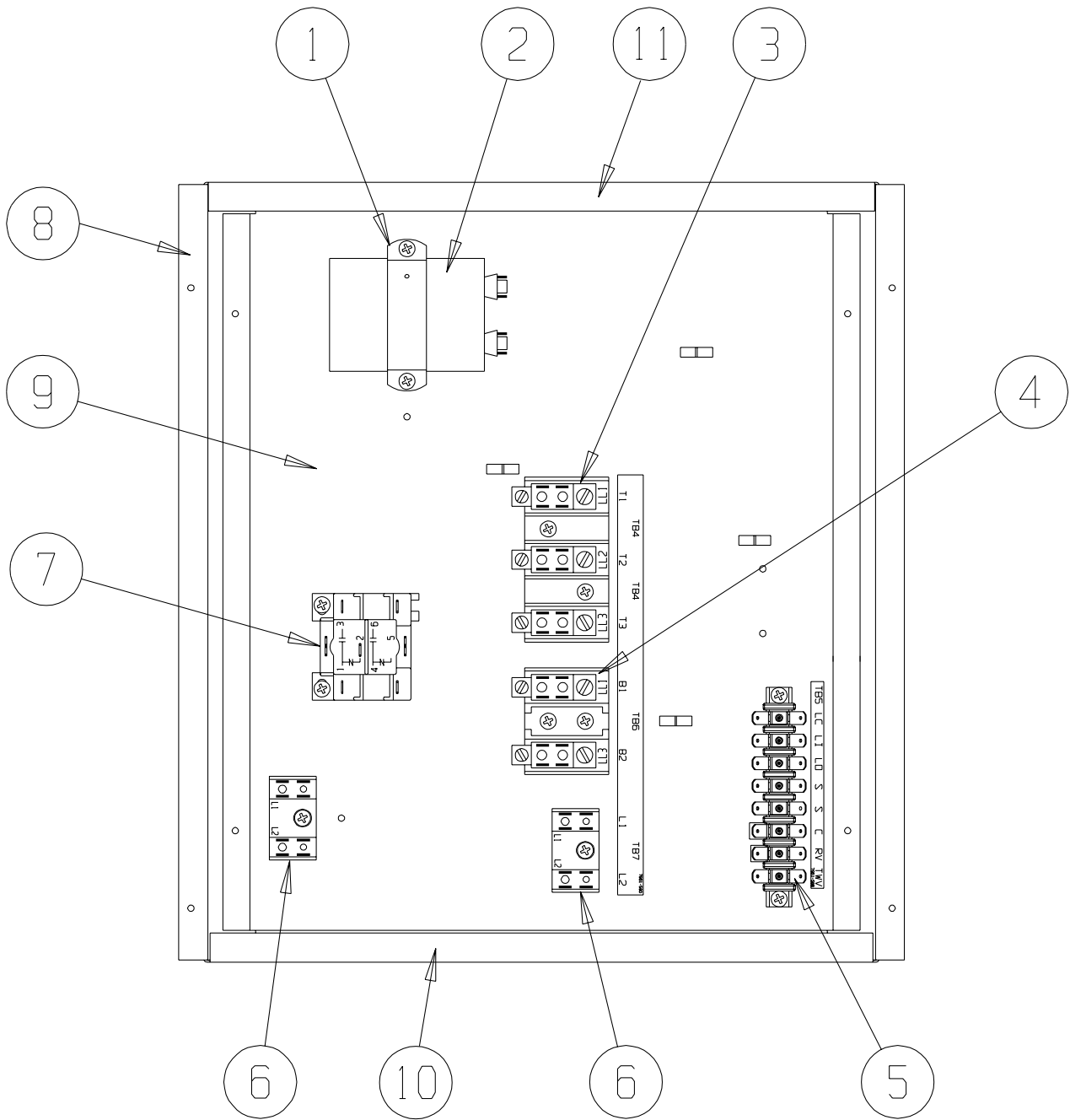

SEXP-374 A

LOWER CONTROL PANEL COMPONENTS

Drawing No.	Part No.	Description	Q24H2DA	Q30H2DA	Q36H2DA	Q42H2DA	Q48H2DA	Q60H2DA	Q24H2DB	Q30H2DB	Q36H2DB	Q42H2DB	Q48H2DB	Q60H2DB	Q24H2DC	Q30H2DC	Q36H2DC	Q42H2DC	Q48H2DC	Q60H2DC	
1	8550-008	Capacitor Strap	X	X	X	X	X	X													
1	8550-003	Capacitor Strap							X							X					
2	8552-002	Fan Capacitor							X							X					
2	8552-050	Compressor Capacitor	X																		
2	8552-052	Compressor Capacitor		X	X	X															
2	8552-061	Compressor Capacitor					X														
2	8552-088	Compressor Capacitor						X													
3	8607-014	Terminal Block 3 Terminal							X		X				X		X			X	
4	8607-013	Terminal Block 2 Terminal	X	X	X	X	X	X								X				X	
5	8607-022	Terminal Block 8 Position	X	X	X	X	X	X	X		X		X		X		X			X	
6	8607-017	Terminal Block 2 Terminal	X	X	X	X	X	X	X		X		X		X		X			X	
7	8201-032	Low Ambient Bypass Relay (Opt)	X	X	X	X	X	X	X		X		X		X		X			X	

DEHUMIDIFICATION MODULE COMPONENTS

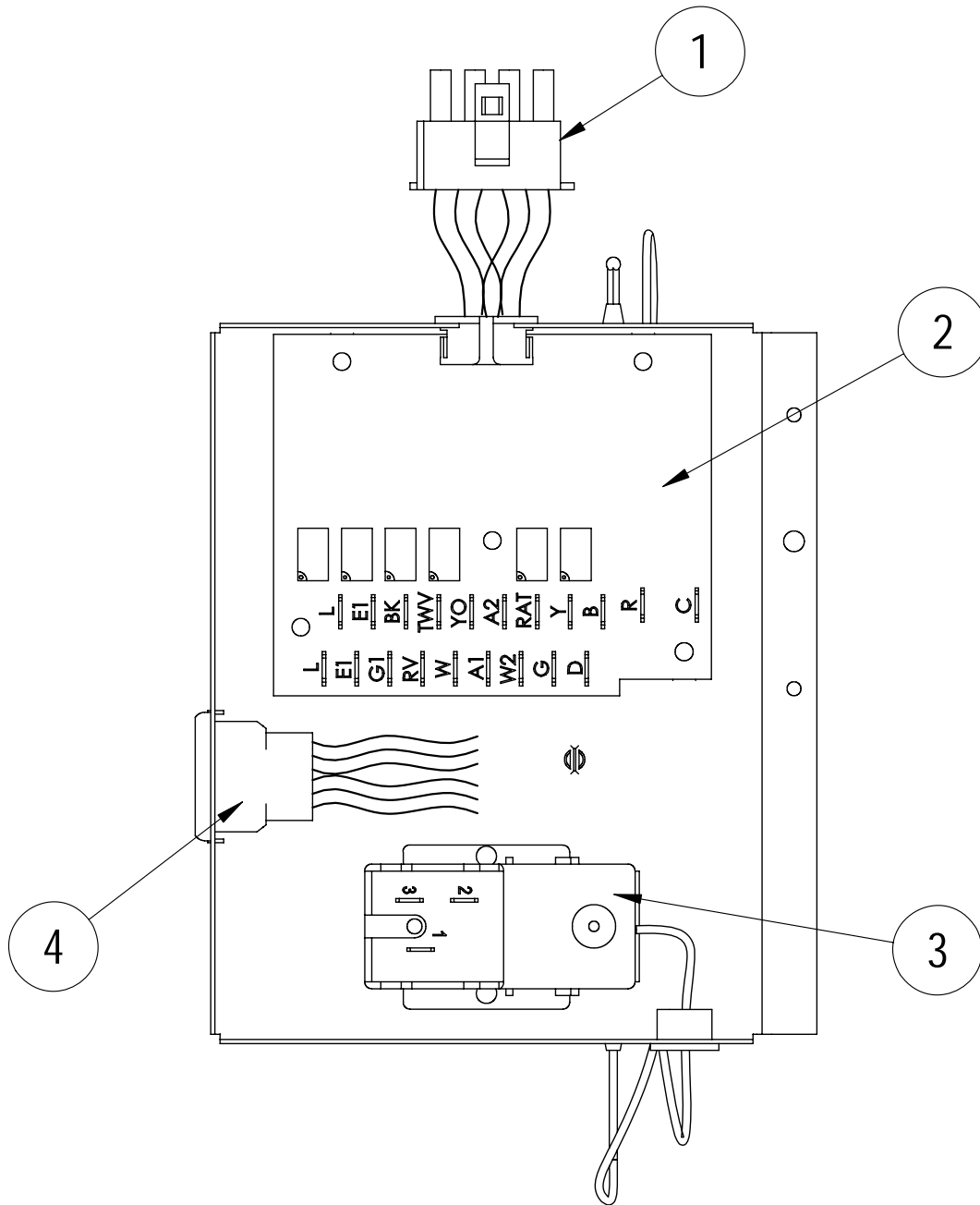

SEXP-418

DEHUMIDIFICATION MODULE COMPONENTS

Drawing No.	Part No.	Description	Options X, E, G, F
1	3000-1295	Wire Harness Male	X
2	8201-113	Logic Board	X
3	8408-037	Return Air Thermostat	X
4	3000-1296	Wire Harness Female	X

BLOWER ASSEMBLY COMPONENTS

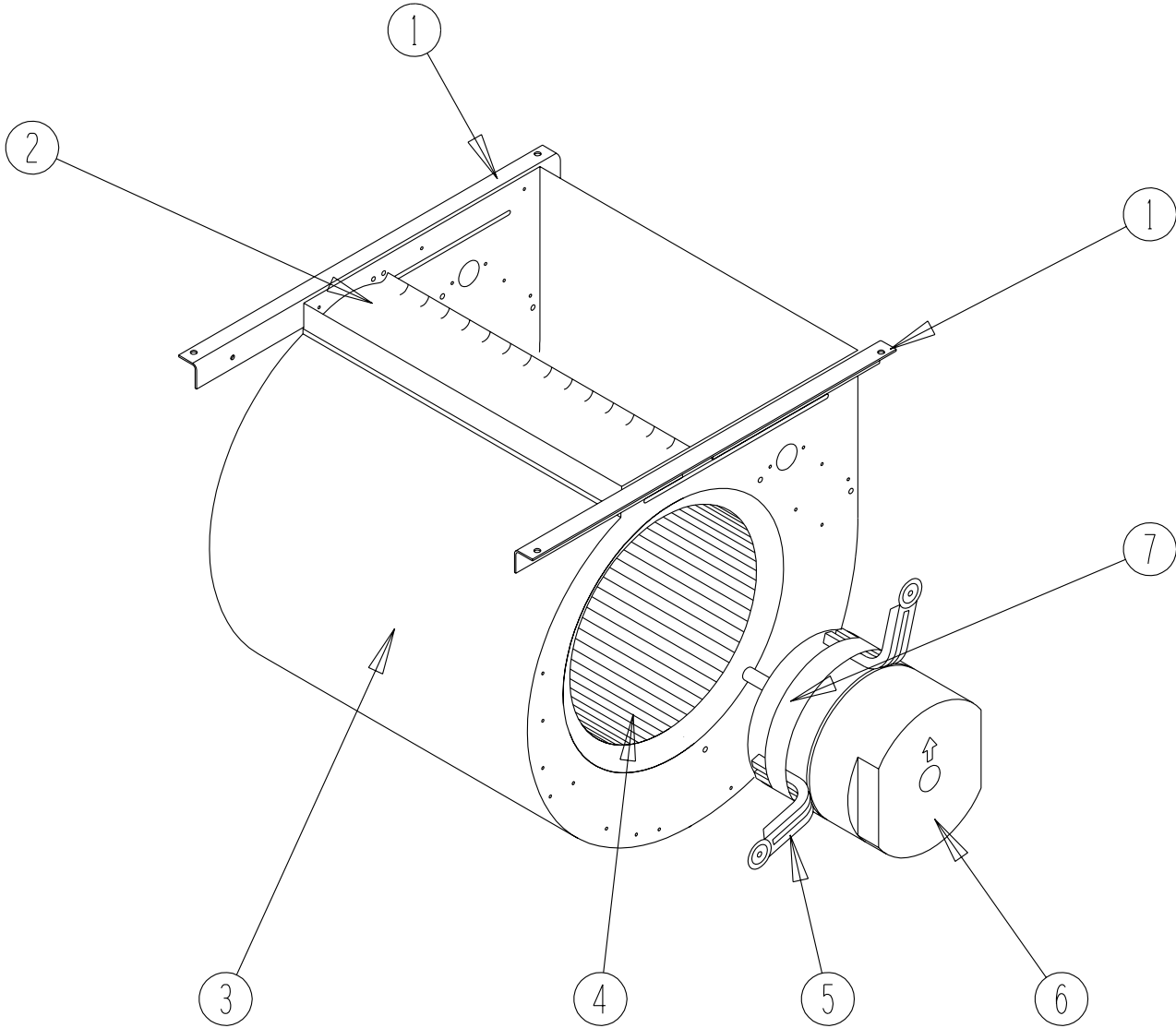

SEXP-245

BLOWER ASSEMBLY COMPONENTS

Drawing No.	Part No.	Description	900-255-001	900-225-002	900-225-004	900-225-005	900-254-001
1	104-980	Blower Angle	2	2	2	2	2
2	144-131	Diffuser	X	X	X	X	X
3	151-110	Blower Housing	X	X	X	X	X
4	5152-061	Blower Wheel	X	X	X	X	X
5	8620-034	Motor Mount Kit	1	1	1	1	1
6	S8106-051-0003B	1/2 HP ECM Motor with Programmed Control	X				
6	C8106-051-0003B	Programmed Motor Control - Only	X				
6	S8106-051-0004A	1/2 HP ECM Motor with Programmed Control		X			
6	C8106-051-0004A	Programmed Motor Control - Only		X			
6	S8106-051-0005B	1/2 HP ECM Motor with Programmed Control			X		
6	C8106-051-0005B	Programmed Motor Control - Only			X		
6	S8106-051-0013A	1/2 HP ECM Motor with Programmed Control				X	
6	C8106-051-0013A	Programmed Motor Control - Only				X	
6	S8107-016-0024B	3/4 HP ECM Motor with Programmed Control					X
6	C8107-016-0024B	Programmed Motor Control - Only					X
7	8620-034	Motor Mount	X	X	X	X	X

OPTIONAL CLIMATE CONTROLS

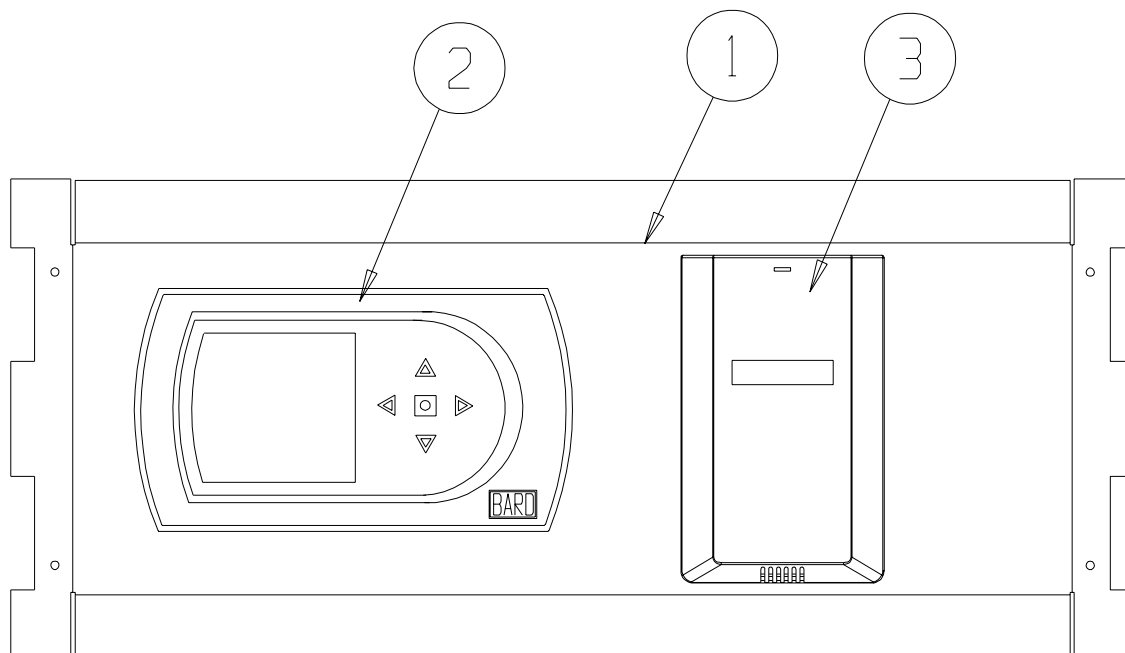

SEXP-0497 A

OPTIONAL CLIMATE CONTROLS

Drawing No.	Part No.	Description	Option X	Option E	Option I	Option J	Option K
1	S127-313-* ①	Thermostat Plate	X				
1	S127-308-* ①	Thermostat Plate		X			
1	S127-372-* ①	Thermostat Plate			X		
1	S127-426-* ①	Thermostat Plate				X	X
2	8403-060	Electronic / Programmable Manual / Auto Changeover		X	X		
2	CS9BE-THO	Temperature, Humidity, Occupancy, BACnet				X	
2	CS9BE-THOC	Temperature, Humidity, Occupancy, BACnet, CO2					X
3	8403-067	CO2 Sensor			X		
NS	3000-1297	Wire Harness, Low Voltage, Terminal Strip to PL2	X				
NS	3000-1298	Wire Harness, Thermostat to PL2		X			
NS	3000-1300	Wire Harness			X		
NS	8607-019	Low Voltage Terminal Strip	X				
NS	4102-063	Wiring Diagram	X				
NS	4102-064	Wiring Diagram		X			
NS	4102-066	Wiring Diagram			X		
NS	4102-079	Wiring Diagram				X	X

* Exterior cabinet parts are manufactured with various paint color options. To ensure that you receive the proper paint color, please reference the following codes:

- Beige -X
- Buckeye Gray -4
- Vinyl - Slate Finish -6
- Vinyl - Platinum Finish -7

NS Not Shown

CLIMATE CONTROL OPTION NOMENCLATURE AS SHOWN IN UNIT MODEL NUMBER

Q 36 H2 D A 09 X X X X X X

X – None

E – Electronic, programmable, manual/auto changeover with humidistat

I – Electronic, programmable, manual/auto changeover with CO2 controller

J – Electronic, programmable, manual/auto changeover with humidity, occupancy & BACnet

K – Electronic, programmable, manual/auto changeover with humidity, occupancy, CO2 & BACnet

WALL SLEEVE CABINET COMPONENTS

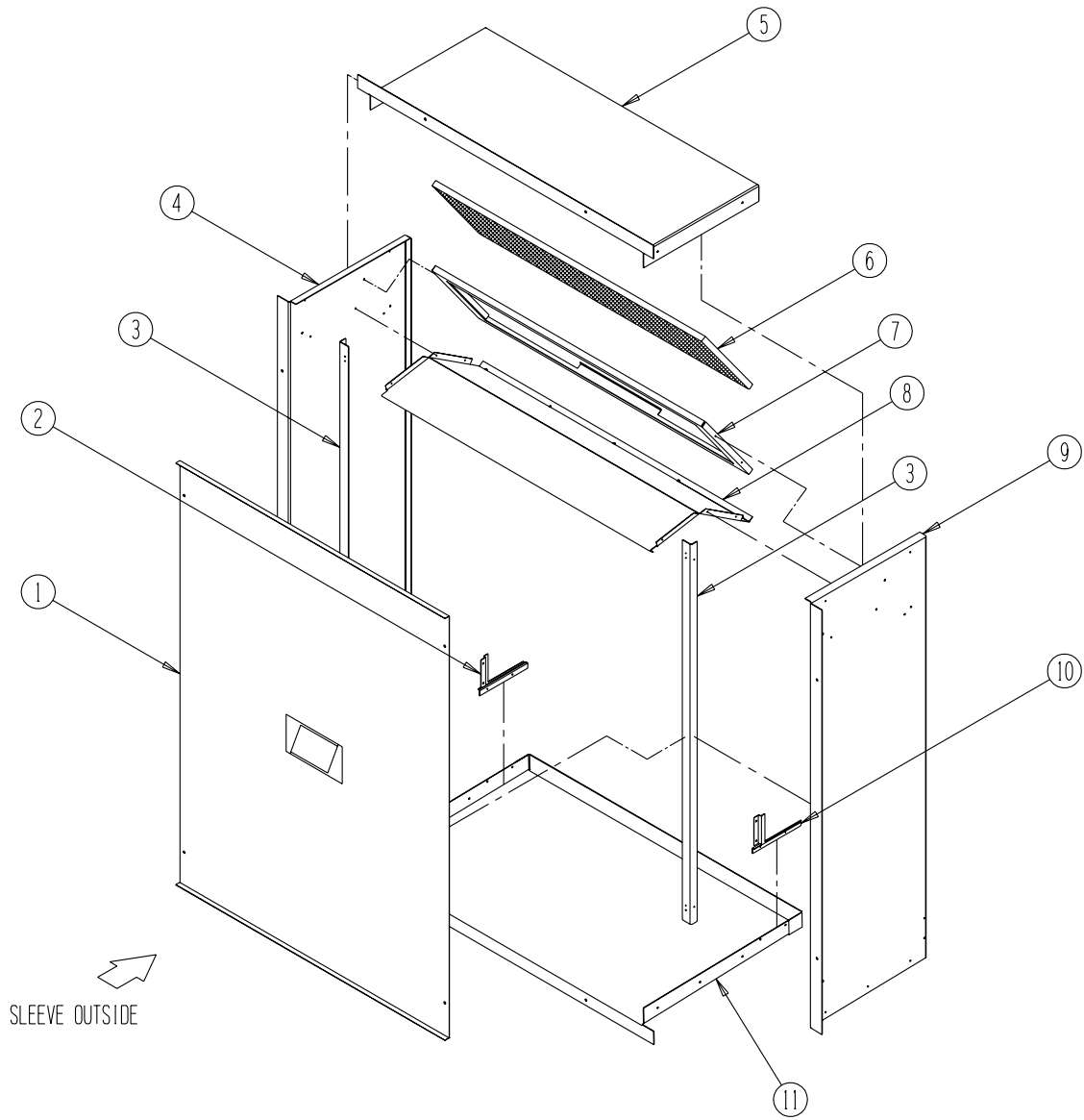

SEXP-281

WALL SLEEVE CABINET COMPONENTS

Drawing No.	Part No.	Description	QWS42	QWS42-16	QWS48	QWS48-16
1	142-056	Cover	X	X		
1	142-068	Cover			X	X
2	137-450-X	Left Side Seal Angle	X	X	X	X
3	104-988-X	Angle	2	2	2	2
4	111-081-X	Left Side	X		X	
4	111-083-X	Left Side		X		X
5	111-047-X	Top	X			
5	110-050-X	Top		X		
5	110-056-X	Top			X	
5	110-070-X	Top				X
6	7003-044	Mist Eliminator	X	X	X	X
7	131-120-X	Filter Tray	X	X		
7	131-128-X	Filter Tray			X	X
8	121-305-X	Partition	X			
8	121-309-X	Partition		X		
8	121-322-X	Partition			X	
8	121-348-X	Partition				X
9	111-080-X	Right Side	X		X	
9	111-082-X	Right Side		X		X
10	137-449-X	Right Side Seal Angle	X	X		
11	111-046-X	Base	X			
11	111-049-X	Base		X		
11	111-055-X	Base			X	
11	111-071-X	Base				X