REPLACEMENT PARTS MANUAL

WALL MOUNTED PACKAGE HEAT PUMPS

Models: J18H2
J24H2

General Notes

- Revised and/or additional pages may be issued from time to time.
- A complete and current manual consists of pages shown in the following contents section.

Important

- Contact the installing and/or local distributor for all parts requirements. Make sure you have the complete model and serial number available from the unit rating plates.

Contents

Description	Page
Cabinet Components	
♦ Exploded View	2
♦ Usage List	3
Functional Components	
♦ Exploded View	4
♦ Usage List	5
Control Panel	
♦ Layout View.....	6
♦ Usage List	7
Blower Housing	
♦ Exploded View	8
♦ Usage List	8



Manual: 2110-1510A
Supersedes: 2110-1510
File: Tab 17
Date: 03-28-14

CABINET COMPONENTS

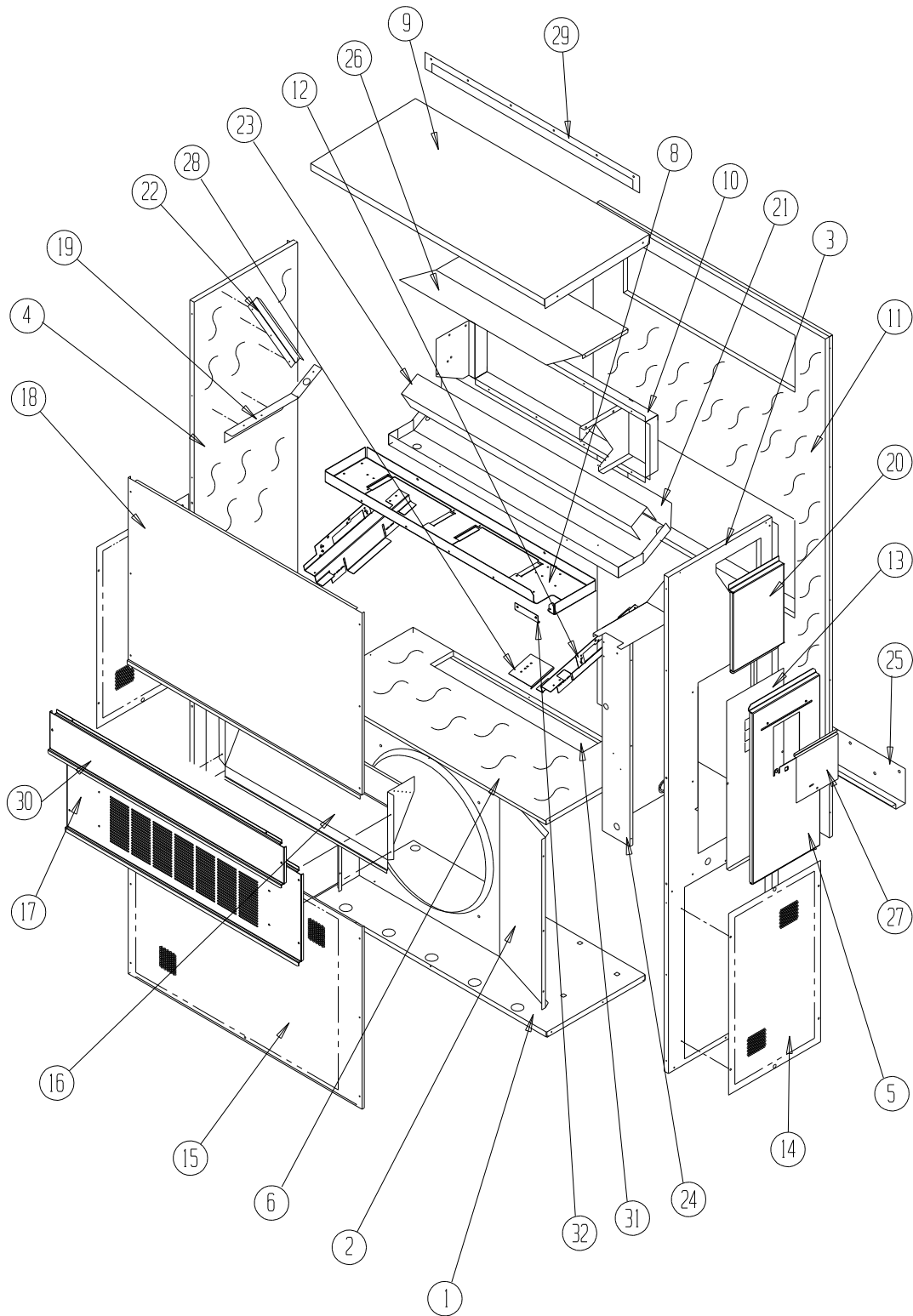

SEXP-684

CABINET COMPONENTS

Dwg No.	Part Number	Description	J18H2-A	J24H2-A, B	J24H2-C
1	127-467	Lower Base	X	X	X
2	125-023	Fan Shroud	X	X	X
3	S501-684-X	Right Side	X	X	X
4	S501-711-X	Left Side	X	X	X
5	S533-228	Control Panel Cover (Outer)	X	X	X
6	S521X204	Condenser Partition	X	X	X
8	121X336	Blower Partition	X	X	X
9	S507-311-X	Top	X	X	X
10	S111X032	Outlet Air Frame Assembly	X	X	X
11	S508-097	Back	X	X	X
12	113X480	Filter Bracket	2	2	2
13	S132-104	Control Panel Cover (Inner)	X	X	
13	S132-172	Control Panel Cover (Inner)			X
14	118-056-X	Side Grille	2	2	2
15	118-050-X	Condenser Grille	X	X	X
16	BFAD-2	Fresh Air Damper Assembly	X	X	X
17	S553-537-X	Vent Option Door	X	X	X
17	S553-539-X	Vent Option Door with ERV	X	X	X
18	S514-276-X	Upper Front	X	X	X
19	105X850	Side Support	X	X	X
20	S543-175-X	Right Side Cover Plate (Outer)	X	X	X
21	S123-126	Drain Pan	X	X	X
22	147-044	Evaporator Support	X	X	X
23	137-694	Bottom Evaporator Fill	X	X	X
24	Control Panel Assembly	See Control Panel Assy. Drawing & Parts List Assy.	X	X	X
25	113-140	Bottom Mounting Bracket	X	X	X
26	135X127	Heat Shield	X	X	X
27	S153-218-X	Disconnect Access Door	X	X	X
28	137-259	Fill Plate	X	X	X
29	113-141-X	Top Rain Flashing	X	X	X
30	S553-538-X	Filter Door	X	X	X
31	S536-176	Cond. Partition Block Off Plate	X	X	X

FUNCTIONAL COMPONENTS

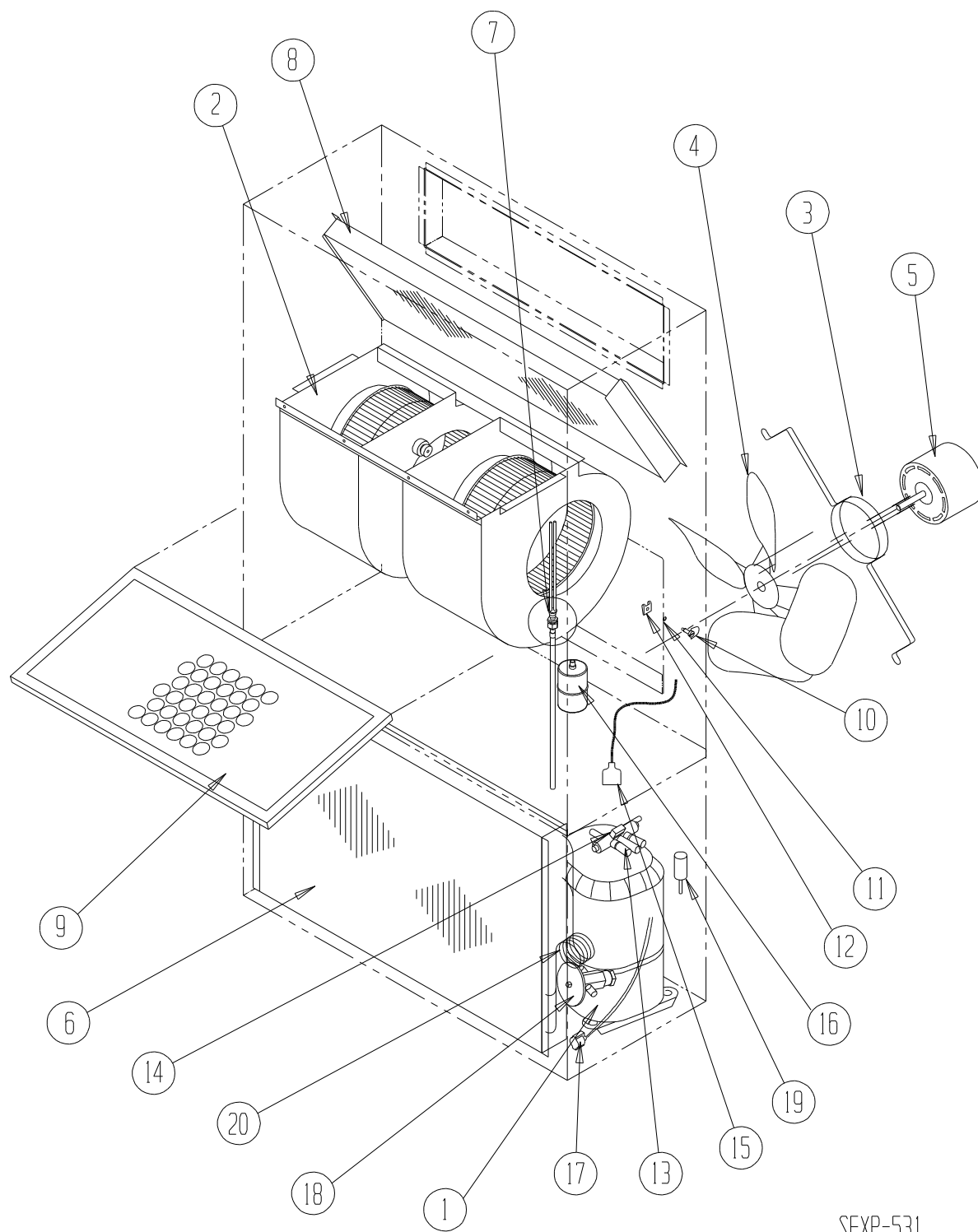

SEXP-531

FUNCTIONAL COMPONENTS

Dwg No.	Part Number	Description	J18H2-A	J24H2-A	J24H2-B	J24H2-C
1	8000-313	Compressor	X			
1	8000-314	Compressor		X		
1	8000-315	Compressor			X	
1	8000-316	Compressor				X
2	S900-291	Blower Assembly	X			
2	S900-248	Blower Assembly		X	X	
2	S900-250	Blower Assembly				X
3	8200-001	Fan Motor Mount	X	X	X	X
4	5151-033	Fan Blade	X	X	X	
4	5151-046	Fan Blade				X
5	8103-016	Condenser Motor	X	X	X	
5	8103-020	Condenser Motor				X
6	5051-115BX	Condenser Coil	X	X	X	X
7	800-0646	Cooling Distributor Assembly	X			
7	800-0647	Cooling Distributor Assembly		X	X	X
8	5060-065BX	Evaporator Coil	X	X	X	X
9	7004-011	Air Filter 1" Throw-Away	X	X	X	X
9	7003-032	Air Filter 1" Washable ①	X	X	X	X
9	7004-025	Air Filter 2" Pleated ①	X	X	X	X
10	1171-022	1/4" Turn Fastener	X	X	X	X
11	1171-024	1/4" Turn Retainer	X	X	X	X
12	1171-023	1/4" Receptacle	X	X	X	X
13	5650-038	Reversing Valve with 24V Solenoid Coil	X	X	X	X
14	5650-042	Rev. Valve Solenoid, Red Casing (Ranco)	X	X	X	X
14	5650-043	Rev. Valve Solenoid, Black Casing (Wilspec)	X	X	X	X
14	5650-046	Rev. Valve Solenoid, Black Casing (San Hua)	X	X	X	X
15	5650-037	Molded Plug 36" Lead	X	X	X	X
16	5201-009	Filter Drier	X	X	X	X
17	8620-224	Defrost Sensor	X	X	X	X
18	5651-191	Heating TXV Thermal Expansion Valve	X	X	X	X
19	1804-0462	High Pressure Switch (Flare) ①	X	X	X	X
20	800-0380	Heating Distributor Assembly	X	X	X	X
NS	1804-0107	Low Pressure Switch (Flare) ①	X	X	X	X
NS	CMA-28	Low Ambient Control (Flare) ①	X	X	X	X
NS	3000-1276	Compressor Wire Harness	X	X		
NS	3000-1244	Compressor Wire Harness			X	X

NS = Not Shown

① = Optional

CONTROL PANEL COMPONENTS

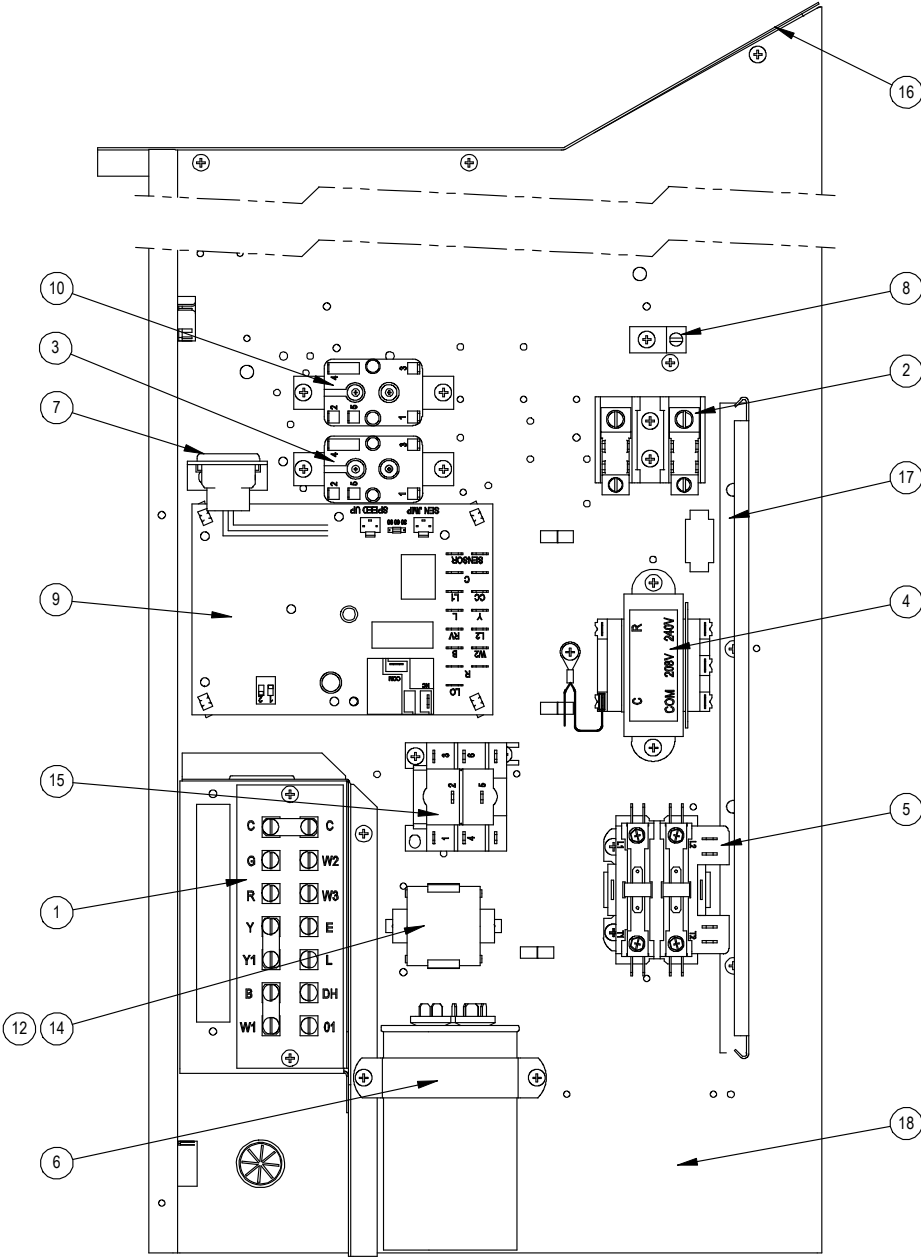

SEXP-168 B

CONTROL PANEL COMPONENTS

Dwg No.	Part Number	Description	J18H2-A	J24H2-A	J24H2-B	J24H2-C
1	8607-019	Low Voltage Terminal Strip	X	X	X	X
2	8607-013	Terminal Block 2 Pole	X	X		
2	8607-014	Terminal Block 3 Pole			X	X
2	8607-015	Phenolic Insulator				X
3	8201-009	Blower Control Relay	X	X	X	
3	8201-032	Blower Control Relay				X
4	8407-035	Transformer	X	X	X	
4	8407-042	Transformer				X
5	8401-007	Compressor Contactor	X	X		
5	8401-002	Compressor Contactor			X	X
6	8552-047	Compressor Capacitor	X			
6	8552-050	Compressor Capacitor		X		
6	8552-002	Outdoor Motor Capacitor			X	X
7	3000-1284	Wire Assembly	X	X	X	X
8	8611-006	Ground Terminal	X	X	X	X
9	8620-223	Heat Pump Control Board	X	X	X	X
10	8201-009	ID Motor Speed Relay SPDT	X			
12	8201-086	Low Ambient Bypass Relay ①	X	X	X	X
13	8607-017	LAC Terminal Block ①	X	X	X	X
14	8551-004	Start Device (PTCR) ①	X	X		
15	8201-032	Outdoor Fan Relay				X
16	117X137	Control Panel Top	X	X	X	X
17	135-122	Wire Shield	X	X	X	X
18	117X123	Control Panel	X	X	X	X
NS	4096-141	Wiring Diagram	X	X		
NS	4096-241	Wiring Diagram			X	
NS	4096-340	Wiring Diagram				X
NS	8201-126	3-Phase Line Monitor			X	X

NS = Not Shown

① = Optional

BLOWER ASSEMBLY

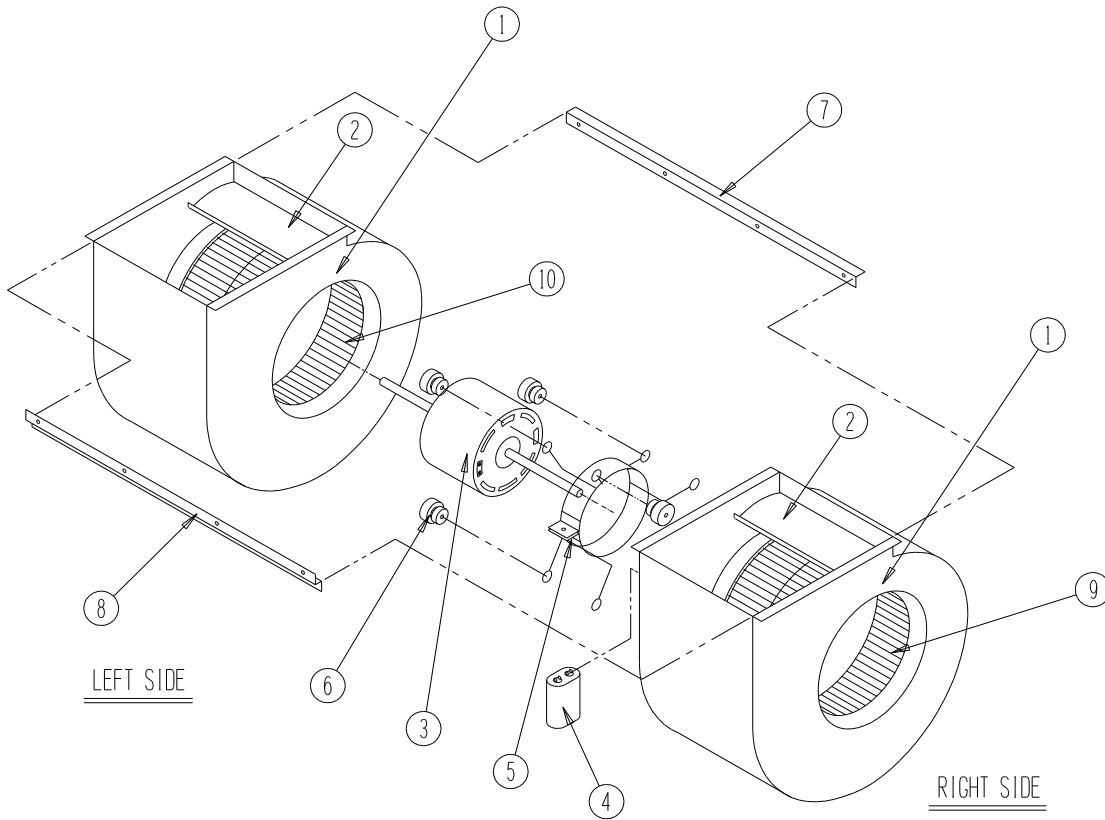

SEXP-346

Dwg No.	Part Number	Description	S900-248	S900-250	S900-291
1	151-115	Blower Housing	2	2	2
2	144-183	Diffuser	2	2	2
3	8102-011	Blower Motor (230/208)	X		
3	8105-033	Blower Motor (460)		X	
3	8102-014	Blower Motor (230/208)			X
4	8552-002	Capacitor	X	X	X
5	8200-031	Motor Mount	X	X	X
6	5451-011	Grommets	6	6	6
7	105-1061	Back Brace	X	X	X
8	103-435	Front Brace	X	X	X
9	5152-092	Wheel 9-6 CW	X	X	X
10	5152-093	Wheel 9-6 CCW	X	X	X