REPLACEMENT PARTS MANUAL

WALL MOUNTED PACKAGED HEAT PUMP

Models:

J42H2-A J48H2-A J60H2-A
J42H2-B J48H2-B J60H2-B
J42H2-C J48H2-C J60H2-C

General Notes

- Revised and/or additional pages may be issued from time to time.
- A complete and current manual consists of pages shown in the following contents section.

Important

- Contact the installing and/or local Bard distributor for all parts requirements. Be sure to have the complete model and serial number available from the unit rating plates.

Contents

<u>Description</u>	<u>Page</u>
Cabinet Components	
♦ Exploded View	2
♦ Usage List	3
♦ Usage List	4
Functional Components	
♦ Exploded View	6
♦ Usage List	7
Control Panel	
♦ Layout View	8
♦ Usage List	9
Blower Assembly	
♦ Exploded View	10
♦ Usage List	10



Manual: 2110-1512C
Supersedes: 2110-1512B
Date: 5-11-18

CABINET COMPONENTS

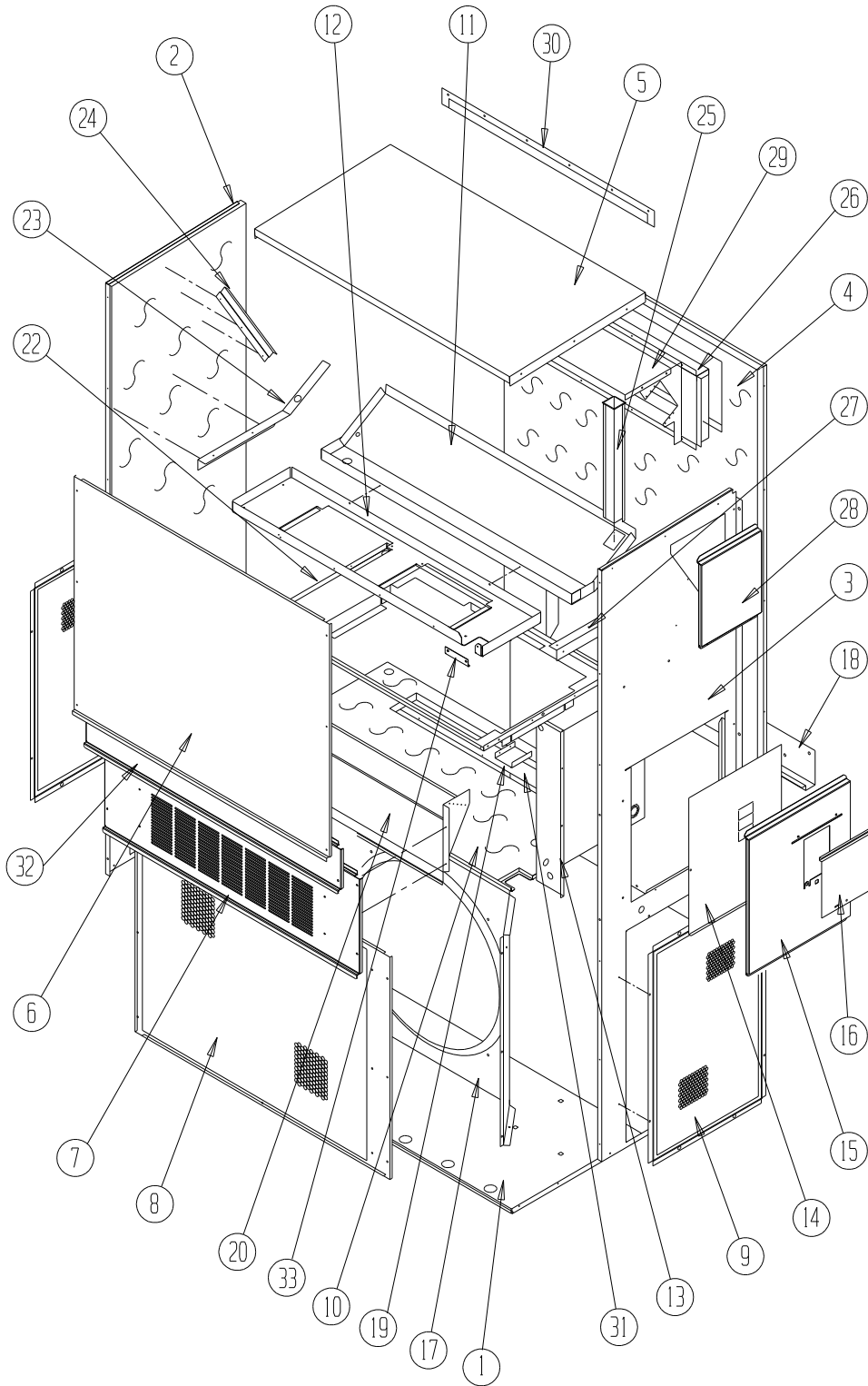

SEXP-658 A

This Drawing is Referenced in Tables on Pages 3 & 4.

CABINET COMPONENTS

Dwg No.	Part Number	Description	J42H2-A, B	J42H2-C	J48H2-A, B	J48H2-C
1	S127-425	Lower Base	X	X	X	X
2	S501-686-X	Left Side	X	X	X	X
3	S501-677-X	Right Side	X	X	X	X
4	S508-098	Back	X	X	X	X
5	S507-307-X	Top	X	X	X	X
6	S515-278-X	Upper Front	X	X	X	X
7	S553-522-X	Vent Option Door	X	X	X	X
7	S553-529-X	Vent Option Door with ERV	X	X	X	X
8	118-048-X	Condenser Grille	X	X	X	X
9	118-057-X	Side Grille	2	2	2	2
10	S521-258	Condenser Partition	X	X	X	X
11	S123-122	Drain Pan	X	X	X	X
12	121X216	Blower Partition	X	X	X	X
13	Control Panel Assy.	See Control Panel Assy. Drawing & Parts List	X	X	X	X
14	S132-114	Control Panel Cover (Inner)	X		X	
14	S132-171	Control Panel Cover (Inner)		X		X
15	S533-225-X	Control Panel Cover (Outer)	X	X	X	X
16	S153-218-X	Disconnect Access Door	X	X	X	X
17	125-024	Fan Shroud	X	X	X	X
18	113-140	Bottom Mounting Bracket	X	X	X	X
19	137-209	Fill	X	X	X	X
20	BFAD-5	Fresh Air Damper Assembly	X	X	X	X
22	131X099	Filter Tray	X	X	X	X
23	105X877	Left Side Support	X	X	X	X
24	147-046	Left Evaporator Support	X	X	X	X
25	135-128	Raceway	2	2	2	2
26	S111X034	Outlet Air Frame Assembly	X	X	X	X
27	105X878	Right Side Support	X	X	X	X
28	S543-172-X	Right Side Cover Plate (Outer)	X	X	X	X
29	135-129	Heat Shield	X	X	X	X
30	113-150-X	Top Rain Flashing	X	X	X	X
31	S536-258	Cond. Partition Block Off Plate	X	X	X	X
32	S553-521-X	Filter Door Assembly	X	X	X	X

CABINET COMPONENTS

Dwg No.	Part Number	Description	J60H2-A, B	J60H2-C
1	S127-425	Lower Base	X	X
2	S501-819-X	Left Side	X	X
3	S501-818-X	Right Side	X	X
4	S508-098	Back	X	X
5	S507-307-X	Top	X	X
6	S515-278-X	Upper Front	X	X
7	S553-522-X	Vent Option Door	X	X
7	S553-529-X	Vent Option Door with ERV	X	X
8	118-052-X	Condenser Grille	X	X
9	118-058-X	Side Grille	2	2
10	S521-258	Condenser Partition	X	X
11	S123-122	Drain Pan	X	X
12	121X216	Blower Partition	X	X
13	Control Panel Assy.	See Control Panel Assy. Drawing & Parts List	X	X
14	S132-114	Control Panel Cover (Inner)	X	
14	S132-171	Control Panel Cover (Inner)		X
15	S533-225-X	Control Panel Cover (Outer)	X	X
16	S153-218-X	Disconnect Access Door	X	X
17	125-029	Fan Shroud	X	X
18	113-140	Bottom Mounting Bracket	X	X
19	137-209	Fill	X	X
20	BFAD-5	Fresh Air Damper Assembly	X	X
22	131X099	Filter Tray	X	X
23	105X877	Left Side Support	X	X
24	147-046	Left Evaporator Support	X	X
25	135-128	Raceway	2	2
26	S111X034	Outlet Air Frame Assembly	X	X
27	105X878	Right Side Support	X	X
28	S543-172-X	Right Side Cover Plate (Outer)	X	X
29	135-129	Heat Shield	X	X
30	113-150-X	Top Rain Flashing	X	X
31	S536-258	Cond. Partition Block Off Plate	X	X
32	S553-521-X	Filter Door Assembly	X	X

This page intentionally left blank.

FUNCTIONAL COMPONENTS

Dwg No.	Part Number	Description	J42H2-A	J42H2-B	J42H2-C	J48H2-A	J48H2-B	J48H2-C	J60H2-A	J60H2-B	J60H2-C
1	8000-332	Compressor	X								
1	8000-333	Compressor		X							
1	8000-334	Compressor			X						
1	8000-343	Compressor				X					
1	8000-344	Compressor					X				
1	8000-345	Compressor						X			
1	8000-324	Compressor							X		
1	8000-325	Compressor								X	
1	8000-326	Compressor									X
2	S900-183	Blower Assembly	X	X		X	X				
2	S900-184	Blower Assembly			X			X			
2	S900-185	Blower Assembly							X	X	
2	S900-186	Blower Assembly									X
3	8200-004	Fan Motor Mount	X	X	X	X	X	X	X	X	X
4	5151-027	Fan Blade	X	X	X	X	X	X	X	X	X
5	8105-039	Condenser Motor	X	X		X	X		X	X	
5	8105-030	Condenser Motor			X			X			X
6	5051-158BX	Condenser Coil	X	X	X	X	X				
6	5051-159BX	Condenser Coil						X	X		X
7	800-0382	Distributor Assembly	X	X	X						
7	800-0383	Distributor Assembly				X	X	X			
7	800-0375	Distributor Assembly							X	X	X
8	5060-137BX	Evaporator Coil	X	X	X						
8	5060-138BX	Evaporator Coil				X	X	X			
8	5060-082BX	Evaporator Coil							X	X	X
9	7004-016	Air Filter 1" Throw-Away	X	X	X	X	X	X	X	X	X
9	7003-030	Air Filter 1" Washable ①	X	X	X	X	X	X	X	X	X
9	7004-027	Air Filter 2" Pleated ①	X	X	X	X	X	X	X	X	X
10	1171-022	1/4 Turn Fastener	X	X	X	X	X	X	X	X	X
11	1171-024	1/4 Turn Retainer	X	X	X	X	X	X	X	X	X
12	1171-023	1/4 Receptacle	X	X	X	X	X	X	X	X	X
13	5650-039	Reversing Valve with 24V Solenoid Coil	X	X	X						
13	5650-040	Reversing Valve with 24V Solenoid Coil				X	X	X	X	X	X
14	5650-042	Rev. Valve Solenoid, Red Casing (Ranco)	X	X	X	X	X	X	X	X	X
14	5650-043	Rev. Valve Solenoid, Black Casing (Wilspec)	X	X	X	X	X	X	X	X	X
14	5650-046	Rev. Valve Solenoid, Black Casing (San Hua)	X	X	X	X	X	X	X	X	X
15	5650-037	Molded Plug 3/6" Lead	X	X	X	X	X	X	X	X	X
16	5201-010	Filter Drier	X	X	X	X	X	X	X	X	X
17	8620-224	Defrost Sensor	X	X	X	X	X	X	X	X	X
18	5651-178	Heating TXV Thermal Expansion Valve	X	X	X	X	X				
18	5651-190	Heating TXV Thermal Expansion Valve							X	X	X
19	8406-142	High Pressure Switch, Screw On, 650 PSIG	X	X	X	X	X	X	X	X	X
20	800-0381	Heating Distributor Assembly	X	X	X	X	X	X			
20	800-0376	Heating Distributor Assembly							X	X	X
NS	8406-135	Low Pressure Switch, Screw On, 14 PSIG	X	X	X	X	X	X	X	X	X
NS	CMA-28	Low Ambient Control (Flare) ①	X	X	X	X	X	X	X	X	X
NS	6031-009	Coremax Valve Core	2	2	2	2	2	2	2	2	2

NS = Not Shown

① = Optional

CONTROL PANEL COMPONENTS

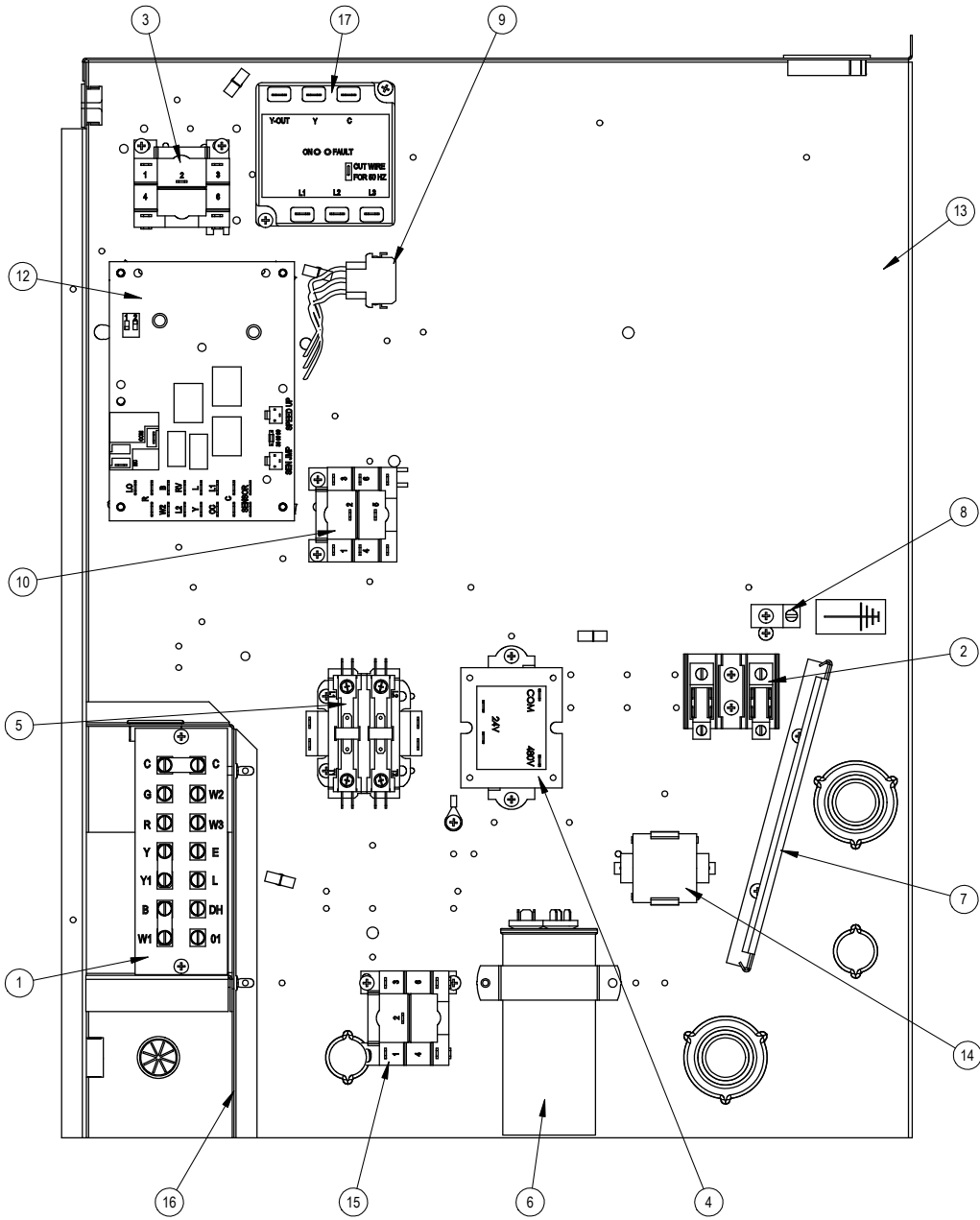

SEXP-528 A

CONTROL PANEL COMPONENTS

Dwg No.	Part Number	Description	J42H2-A	J42H2-B	J42H2-C	J48H2-A	J48H2-B	J48H2-C	J60H2-A	J60H2-B	J60H2-C
1	8607-019	Low Voltage Terminal Strip	X	X	X	X	X	X	X	X	X
2	8607-013	Terminal Block 2 Pole	X			X			X		
2	8607-014	Terminal Block 3 Pole		X	X		X	X		X	X
2	8607-015	Phenolic Insulator		X			X			X	
3	8201-009	Blower Control Relay	X	X		X	X		X	X	
3	8201-032	Blower Control Relay			X			X			X
4	8407-068	Transformer	X	X		X	X		X	X	
4	8407-069	Transformer			X			X			X
5	8401-006	Compressor Contactor	X								
5	8401-002	Compressor Contactor		X	X		X	X		X	X
5	8401-025	Compressor Contactor				X			X		
6	8552-089	Compressor Capacitor	X								
6	8552-005	Outdoor Motor Capacitor		X			X			X	
6	8552-026	Outdoor Motor Capacitor			X			X			X
6	8552-089	Compressor Capacitor				X					
6	8552-058	Compressor Capacitor							X		
7	135-130	Wire Shield	X	X	X	X	X	X	X	X	X
8	8611-006	Ground Terminal	X	X	X	X	X	X	X	X	X
9	3000-1282	Wire Assembly	X	X	X	X	X	X	X	X	X
10	8201-086	Low Ambient Bypass Relay ①	X	X	X	X	X	X	X	X	X
12	8620-223	Heat Pump Control Board	X	X	X	X	X	X	X	X	X
13	117X143	Control Panel	X	X	X	X	X	X	X	X	X
14	8551-004	Start Device (PTCR) ①	X			X					
15	8201-032	Outdoor Fan Relay			X			X			X
16	117X139	Control Panel Top	X	X	X	X	X	X	X	X	X
17	8201-126	Phase Monitor		X	X		X	X		X	X
NS	4096-139	Wiring Diagram	X			X			X		
NS	4096-240	Wiring Diagram		X			X			X	
NS	4096-339	Wiring Diagram			X			X			X

NS = Not Shown

① = Optional

BLOWER ASSEMBLY

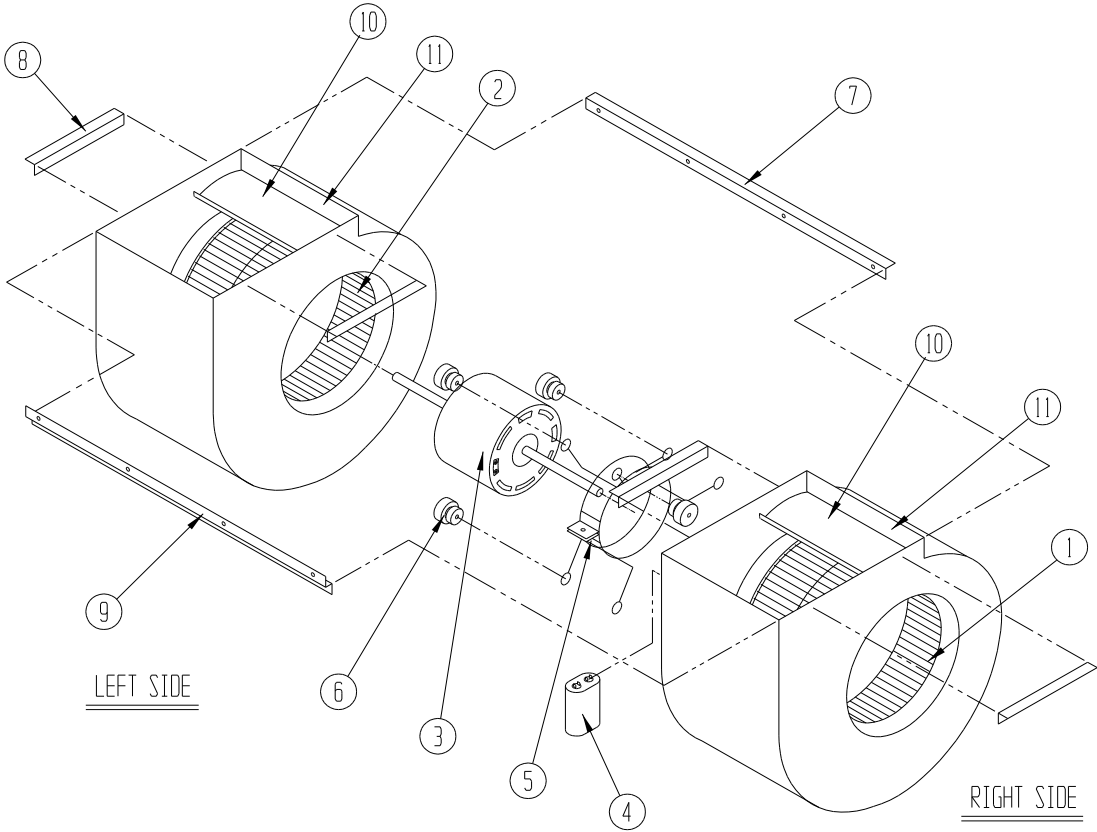

SEXP-178

Dwg No.	Part Number	Description	S900-183	S900-184	S900-185	S900-186
1	5152-011	10 Inch Wheel (CW)			X	X
1	5152-057	9 Inch Wheel (CW)	X	X		
2	5152-012	10 Inch Wheel (CCW)			X	X
2	5152-058	9 Inch Wheel (CCW)	X	X		
3	S8106-046	Blower Motor (230/208)	X		X	
3	8106-025	Blower Motor (460)		X		X
4	8552-005	Capacitor	X	X	X	X
4	8552-091	Capacitor	X		X	
5	8200-040	Motor Mount	X	X	X	X
6	5451-011	Grommets	6	6	6	6
7	105-881	Back Brace	X	X	X	X
8	105-880	Side Angle	4	4	4	4
9	103-389	Front Brace	X	X	X	X
10	151-101	Blower Housing	2	2	2	2
11	144-166	Diffuser	2	2	2	2