REPLACEMENT PARTS MANUAL

WALL MOUNTED PACKAGE AIR CONDITIONER

Models: **W38A2**
W49A2
W61A2

General Notes

- Revised and/or additional pages may be issued from time to time.
- A complete and current manual consists of pages shown in the following contents section.

Important

- Contact the installing and/or local Bard distributor for all parts requirements. Make sure you have the complete model and serial number available from the unit rating plates.

Contents

<u>Description</u>	<u>Page</u>
Cabinet Components	
♦ Exploded View	2
♦ Usage List	3
♦ Usage List	4
Functional Components	
♦ Exploded View	6
♦ Usage List	7
Control Panel	
♦ Exploded View	8
♦ Usage List	9
Blower Assembly	
♦ Exploded View	10
♦ Usage List	10

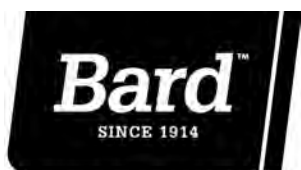

Climate Control Solutions

Bard Manufacturing Company, Inc.
Bryan, Ohio 43506

Since 1914...Moving ahead, just as planned.

Manual: 2110-1513
Supersedes: **NEW**
File: Tab 16
Date: 04-03-14

CABINET COMPONENTS

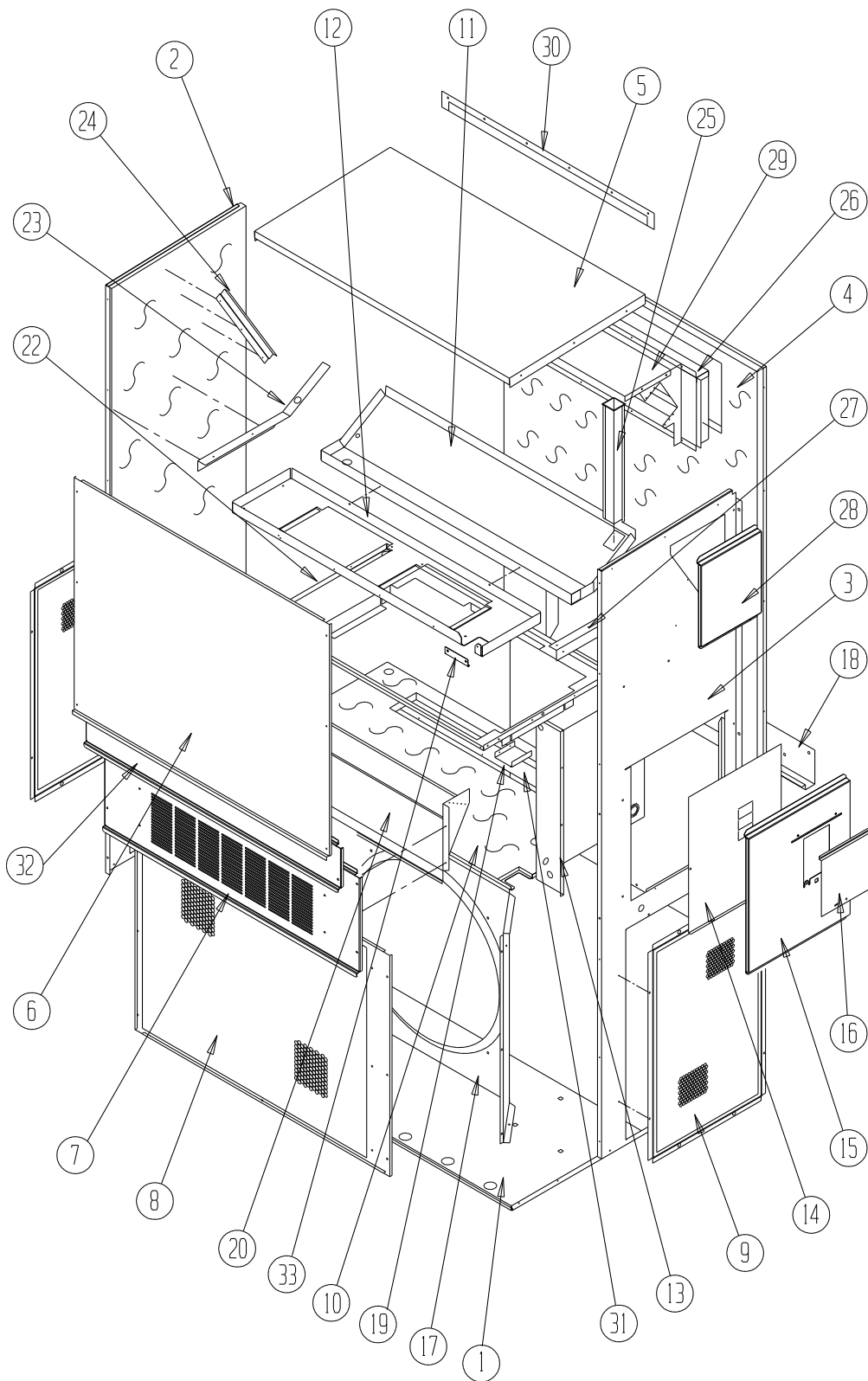

SEXP-658 A

This drawing is referenced in Tables on Pages 3 and 4

CABINET COMPONENTS

Dwg No.	Part Number	Description	W38A2-A, B	W38A2-C	W49A2-A, B	W49A2-C
1	S127-425	Lower Base	X	X	X	X
1	S127-430 ③	Lower Base	X	X	X	X
2	S501-686-* ①	Left Side	X	X	X	X
2	S501-699 ②	Left Side	X	X	X	X
2	S501-701 ③	Left Side	X	X	X	X
3	S501-677-* ①	Right Side	X	X	X	X
3	S501-698 ②	Right Side	X	X	X	X
3	S501-700 ③	Right Side	X	X	X	X
4	S508-098	Back	X	X	X	X
4	S508-275 ②	Back	X	X	X	X
4	S508-221 ③	Back	X	X	X	X
5	S507-307-* ①	Top	X	X	X	X
5	S507-309 ②	Top	X	X	X	X
5	S507-310 ③	Top	X	X	X	X
6	S515-230-* ①	Upper Front	X	X	X	X
6	S514-231 ②	Upper Front	X	X	X	X
6	S514-232 ③	Upper Front	X	X	X	X
7	S553-522-* ①	Vent Option Door	X	X	X	X
7	S553-529-* ①	Vent Option Door with ERV	X	X	X	X
7	S553-525 ②	Vent Option Door	X	X	X	X
7	S553-527 ③	Vent Option Door	X	X	X	X
8	118-048-* ①	Condenser Grille	X	X	X	X
8	118-064 ②	Condenser Grille	X	X	X	X
8	118-072 ③	Condenser Grille	X	X	X	X
9	118-057-* ①	Side Grille	2	2	2	2
9	118-063 ②	Side Grille	2	2	2	2
9	118-073 ③	Side Grille	2	2	2	2
10	S521X258	Condenser Partition	X	X	X	X
11	S123-122	Drain Pan	X	X	X	X
11	S123-125 ②③	Drain Pan	X	X	X	X
12	121X216	Blower Partition	X	X	X	X
13	Control Panel Assy.	See Control Panel Assy. Drawing & Parts List	X	X	X	X
14	S132-114	Control Panel Cover (Inner)	X		X	
14	S132-171	Control Panel Cover (Inner)		X		X
15	S533-225-* ①	Control Panel Cover (Outer)	X	X	X	X
15	S533-229 ②	Control Panel Cover (Outer)	X	X	X	X
15	S533-230 ③	Control Panel Cover (Outer)	X	X	X	X
16	S153-218-* ①	Disconnect Access Door	X	X	X	X
16	S153-387 ②	Disconnect Access Door	X	X	X	X
16	S153-405 ③	Disconnect Access Door	X	X	X	X
17	125-024	Fan Shroud	X	X	X	X
17	125-058 ③	Fan Shroud	X	X	X	X
18	113-140	Bottom Mounting Bracket	X	X	X	X
19	137-209	Fill	X	X	X	X
20	BFAD-5	Fresh Air Damper Assembly	X	X	X	X
22	131X099	Filter Tray	X	X	X	X
23	105X877	Left Side Support	X	X	X	X
24	147-046	Left Evaporator Support	X	X	X	X
25	135-128	Raceway	2	2	2	2
26	S111X034	Outlet Air Frame Assembly	X	X	X	X
27	105X878	Right Side Support	X	X	X	X
28	S543-172-* ①	Right Side Cover Plate (Outer)	X	X	X	X
28	S543-176 ②	Right Side Cover Plate (Outer)	X	X	X	X
28	S543-177 ③	Right Side Cover Plate (Outer)	X	X	X	X
29	135-129	Heat Shield	X	X	X	X
30	113-150-* ①	Top Rain Flashing	X	X	X	X
30	113-359 ③	Top Rain Flashing	X	X	X	X
31	S536-258	Cond. Partition Block Off Plate	X	X	X	X
32	S553-521-* ①	Filter Door Assembly	X	X	X	X
32	S553-526 ②	Filter Door Assembly	X	X	X	X
32	S553-528 ③	Filter Door Assembly	X	X	X	X

① Exterior cabinet parts are manufactured with various paint color options. To ensure that you receive the proper paint color, you must include the complete model and serial number of the unit for which cabinet parts are being ordered.

② Note: Exterior cabinet parts are manufactured from aluminum Code "A"

③ Note: Exterior cabinet parts are manufactured from stainless steel Code "S"

This Table is references drawing on Page 2

CABINET COMPONENTS

Dwg No.	Part Number	Description	W61A2-A, B	W61A2-C
1	S127-425	Lower Base	X	X
1	S127-430 ③	Lower Base	X	X
2	S501-819-* ①	Left Side	X	X
2	S501-822 ②	Left Side	X	X
2	S501-820 ③	Left Side	X	X
3	S501-818-* ①	Right Side	X	X
3	S501-823 ②	Right Side	X	X
3	S501-821 ③	Right Side	X	X
4	S508-098	Back	X	X
4	S508-275 ②	Back	X	X
4	S508-221 ③	Back	X	X
5	S507-307-* ①	Top	X	X
5	S507-309 ②	Top	X	X
5	S507-310 ③	Top	X	X
6	S515-230-* ①	Upper Front	X	X
6	S514-231 ②	Upper Front	X	X
6	S514-232 ③	Upper Front	X	X
7	S553-522-* ①	Vent Option Door	X	X
7	S553-529-* ①	Vent Option Door with ERV	X	X
7	S553-525 ②	Vent Option Door	X	X
7	S553-527 ③	Vent Option Door	X	X
8	118-052-* ①	Condenser Grille	X	X
8	118-080 ②	Condenser Grille	X	X
8	118-078 ③	Condenser Grille	X	X
9	118-058-* ①	Side Grille	2	2
9	118-081 ②	Side Grille	2	2
9	118-079 ③	Side Grille	2	2
10	S521-258	Condenser Partition	X	X
11	S123-122	Drain Pan	X	X
11	S123-125 ②③	Drain Pan	X	X
12	121X216	Blower Partition	X	X
13	Control Panel Assy.	See Control Panel Assy. Drawing & Parts List	X	X
14	S132-114	Control Panel Cover (Inner)	X	
14	S132-171	Control Panel Cover (Inner)		X
15	S533-225-* ①	Control Panel Cover (Outer)	X	X
15	S533-229 ②	Control Panel Cover (Outer)	X	X
15	S533-230 ③	Control Panel Cover (Outer)	X	X
16	S153-218-* ①	Disconnect Access Door	X	X
16	S153-387 ②	Disconnect Access Door	X	X
16	S153-405 ③	Disconnect Access Door	X	X
17	125-029	Fan Shroud	X	X
17	125-059 ③	Fan Shroud	X	X
18	113-140	Bottom Mounting Bracket	X	X
19	137-209	Fill	X	X
20	BFAD-5	Fresh Air Damper Assembly	X	X
22	131X099	Filter Tray	X	X
23	105X877	Left Side Support	X	X
24	147-046	Left Evaporator Support	X	X
25	135-128	Raceway	2	2
26	S111X034	Outlet Air Frame Assembly	X	X
27	105X878	Right Side Support	X	X
28	S543-172-* ①	Right Side Cover Plate (Outer)	X	X
28	S543-176 ②	Right Side Cover Plate (Outer)	X	X
28	S543-177 ③	Right Side Cover Plate (Outer)	X	X
29	135-129	Heat Shield	X	X
30	113-150-* ①	Top Rain Flashing	X	X
30	113-359 ③	Top Rain Flashing	X	X
31	S536-258	Cond. Partition Block Off Plate	X	X
32	S553-521-* ①	Filter Door Assembly	X	X
32	S553-526 ②	Filter Door Assembly	X	X
32	S553-528 ③	Filter Door Assembly	X	X

① Exterior cabinet parts are manufactured with various paint color options. To ensure that you receive the proper paint color, you must include the complete model and serial number of the unit for which cabinet parts are being ordered.

② Note: Exterior cabinet parts are manufactured from aluminum Code "A"

③ Note: Exterior cabinet parts are manufactured from stainless steel Code "S"

This Table is references drawing on Page 2

This page intentionally left blank.

FUNCTIONAL COMPONENTS

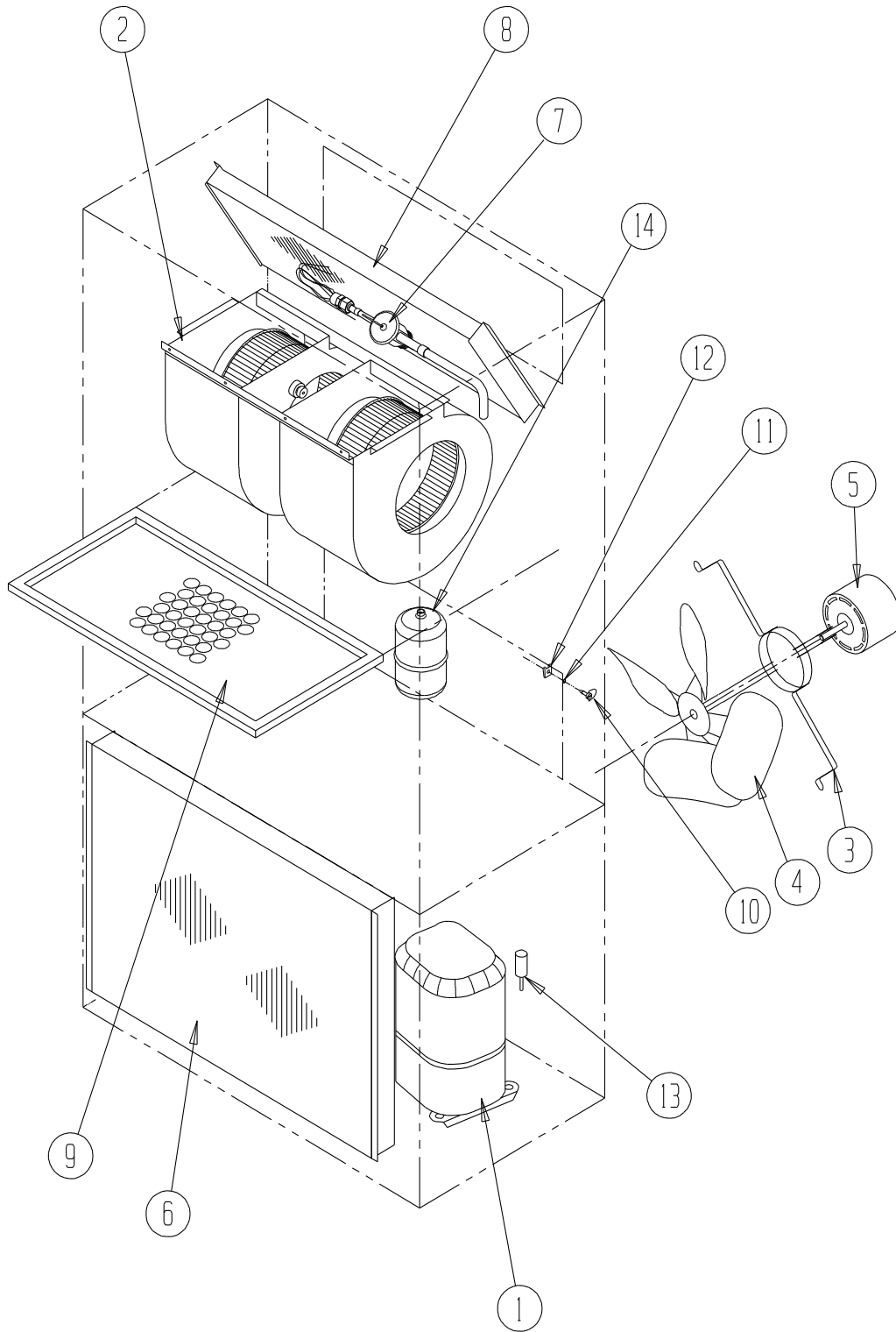

SEXP-554

This Exploded View references Table on Page 7

FUNCTIONAL COMPONENTS

Dwg. No.	Part Number	Description	W38A2-A	W38A2-B	W38A2-C	W49A2-A	W49A2-B	W49A2-C	W61A2-A	W61A2-B	W61A2-C
1	8000-309	Compressor	X								
1	8000-310	Compressor		X							
1	8000-311	Compressor			X						
1	8000-343	Compressor				X					
1	8000-344	Compressor					X				
1	8000-345	Compressor						X			
1	8000-327	Compressor							X		
1	8000-328	Compressor								X	
1	8000-329	Compressor									X
2	S900-272-003	Blower Assembly	X	X	X						
2	S900-273-005	Blower Assembly				X	X	X			
2	S900-273-006	Blower Assembly							X	X	X
3	8200-004	Fan Motor Mount	X	X	X	X	X	X	X	X	X
4	5151-027	Fan Blade	X	X	X	X	X	X	X	X	X
5	8105-030	Condenser Motor			X			X			X
5	8105-066	Condenser Motor	X	X		X	X		X	X	
6	5051-151BX	Condenser Coil	X	X	X						
6	5051-163BX	Condenser Coil				X	X	X			
6	5051-088BX	Condenser Coil							X	X	X
7	5651-186	Expansion Valve	X	X	X						
7	5651-169	Expansion Valve				X	X	X			
7	5651-170	Expansion Valve							X	X	X
7	800-0340	Distributor Assembly	X	X	X						
7	800-0342	Distributor Assembly				X	X	X			
7	800-0395	Distributor Assembly							X	X	X
8	5060-147BX	Evaporator Coil	X	X	X						
8	5060-138BX	Evaporator Coil				X	X	X			
8	5060-082BX	Evaporator Coil							X	X	X
9	7004-016	Air Filter 1" Throw-Away	X	X	X	X	X	X	X	X	X
9	7003-030	Air Filter 1" Washable	X	X	X	X	X	X	X	X	X
9	7004-027	Air Filter 2" Pleated	X	X	X	X	X	X	X	X	X
10	1171-022	1/4 Turn Fastener	X	X	X	X	X	X	X	X	X
11	1171-024	1/4 Turn Retainer	X	X	X	X	X	X	X	X	X
12	1171-023	1/4 Receptacle	X	X	X	X	X	X	X	X	X
13	1804-0462	High Pressure Switch (Flare)	X	X	X	X	X	X	X	X	X
14	5201-022	Filter Drier	X	X	X	X	X	X	X	X	X
NS	1804-0386	Low Pressure Switch (Flare) ①	X	X	X	X	X	X	X	X	X
NS	CMA-28	Low Ambient Control	X	X	X	X	X	X	X	X	X
NS	8407-003	Step Down Transformer			X			X			X

NS – Not Shown

① – Optional on these models

This Table references Exploded View on Page 6

CONTROL PANEL

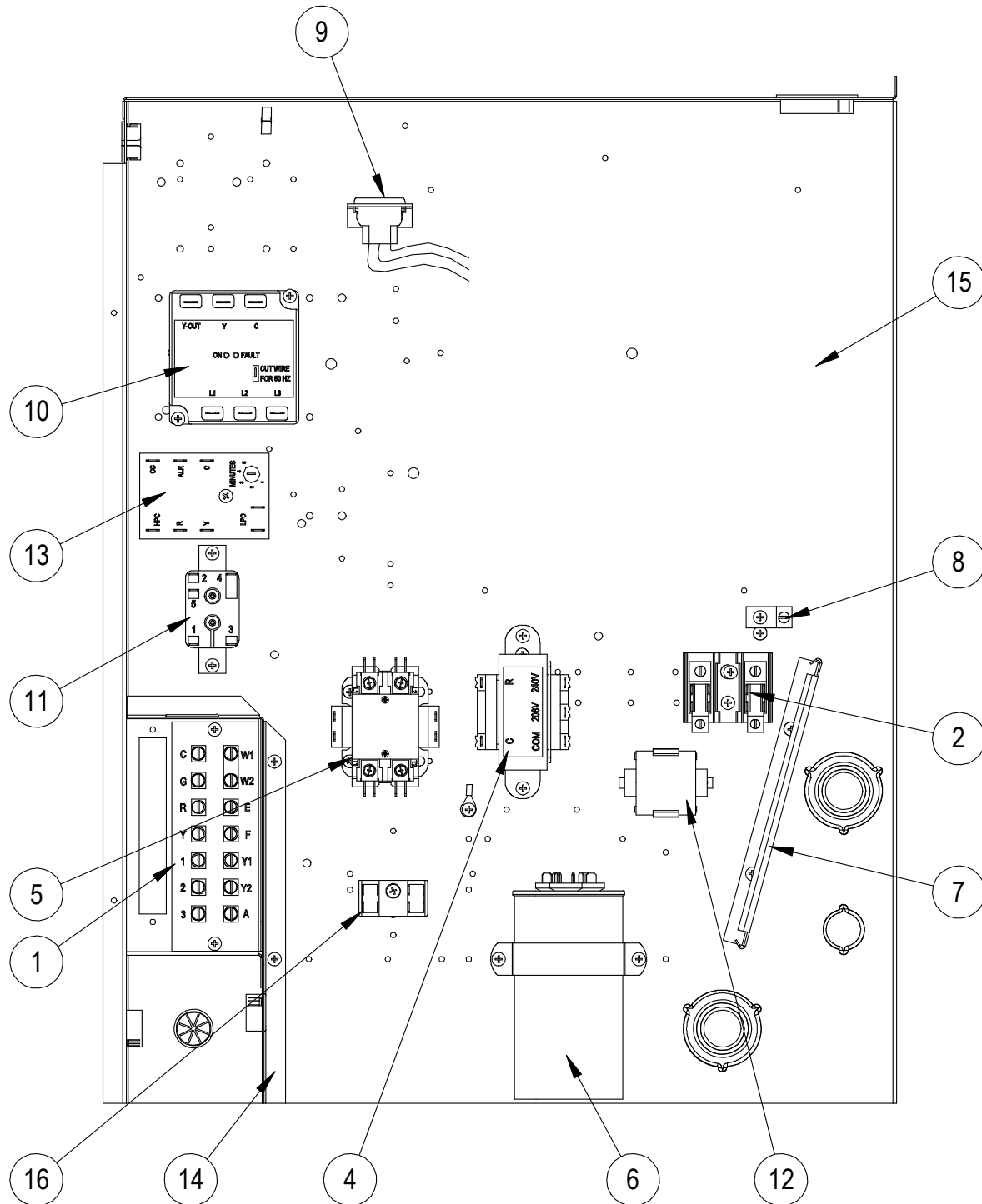

SEXP-555

This drawing is referenced in Table on Page 9

CONTROL PANEL

Dwg. No.	Part Number	Description	W38A2-A	W38A2-B	W38A2-C	W49A2-A	W49A2-B	W49A2-C	W61A2-A	W61A2-B	W61A2-C
1	8607-024	Low Voltage Terminal Strip	X	X	X	X	X	X	X	X	X
2	8607-013	Terminal Block 2 Pole	X			X			X		
2	8607-014	Terminal Block 3 Pole		X	X		X	X		X	X
2	8607-015	Phenolic Insulator			X			X			X
4	8407-035	Transformer	X	X		X	X	X	X		X
4	8407-042	Transformer			X					X	
5	8401-002	Compressor Contactor 3 Pole		X	X		X	X		X	X
5	8401-025	Compressor Contactor 2 Pole	X			X			X		
6	8552-079	Compressor Capacitor	X								
6	8552-089	Compressor Capacitor				X					
6	8552-058	Compressor Capacitor							X		
6	8552-005	Outdoor Motor Capacitor		X			X			X	
6	8552-091	Outdoor Motor Capacitor			X			X			X
7	135-130	Wire Shield	X	X	X	X	X	X	X	X	X
8	8611-006	Ground Terminal	X	X	X	X	X	X	X	X	X
9	3000-1329	6 Pin Connector	X	X	X	X	X	X	X	X	X
10	8201-126	Phase Monitor		X	X	X	X		X	X	X
11	8201-062	Alarm Relay ①	X	X	X	X	X	X	X	X	X
12	8551-004	Start Device	X					X			
13	8201-148	Compressor Control Module	X	X	X	X	X	X	X	X	X
14	117X139	Low Voltage Box	X	X	X	X	X	X	X	X	X
15	117X143	Control Panel	X	X	X	X	X	X	X	X	X
16	8607-017	Terminal Block ①	X	X	X	X	X	X	X	X	X
NS	8615-039	Circuit Breaker 45A 2 Pole ②	X								
NS	8615-042	Circuit Breaker 35A 3 Pole ②		X							
NS	8615-067	Toggle Disconnect ②			X			X			X
NS	8615-040	Circuit Breaker 50A 2 Pole ②				X					
NS	8615-041	Circuit Breaker 60A 2 Pole ②							X		
NS	8615-044	Circuit Breaker 45A 3 Pole ②					X				
NS	8615-045	Circuit Breaker 50A 3 Pole ②								X	
NS	4095-152	Wiring Diagram	X			X			X		
NS	4095-247	Wiring Diagram		X			X			X	
NS	4095-346	Wiring Diagram			X			X			X
NS	8614-041	Fuse Block			X			X			X
NS	8614-046	5A Fuse			2			2			2

① Optional on these models.

② Circuit breakers listed are for units without electric heat "OZ" models.
See Heater Replacement Parts Manual for units with electric heat.

NS = Not shown

This Table is references drawing on Page 8

BLOWER ASSEMBLY

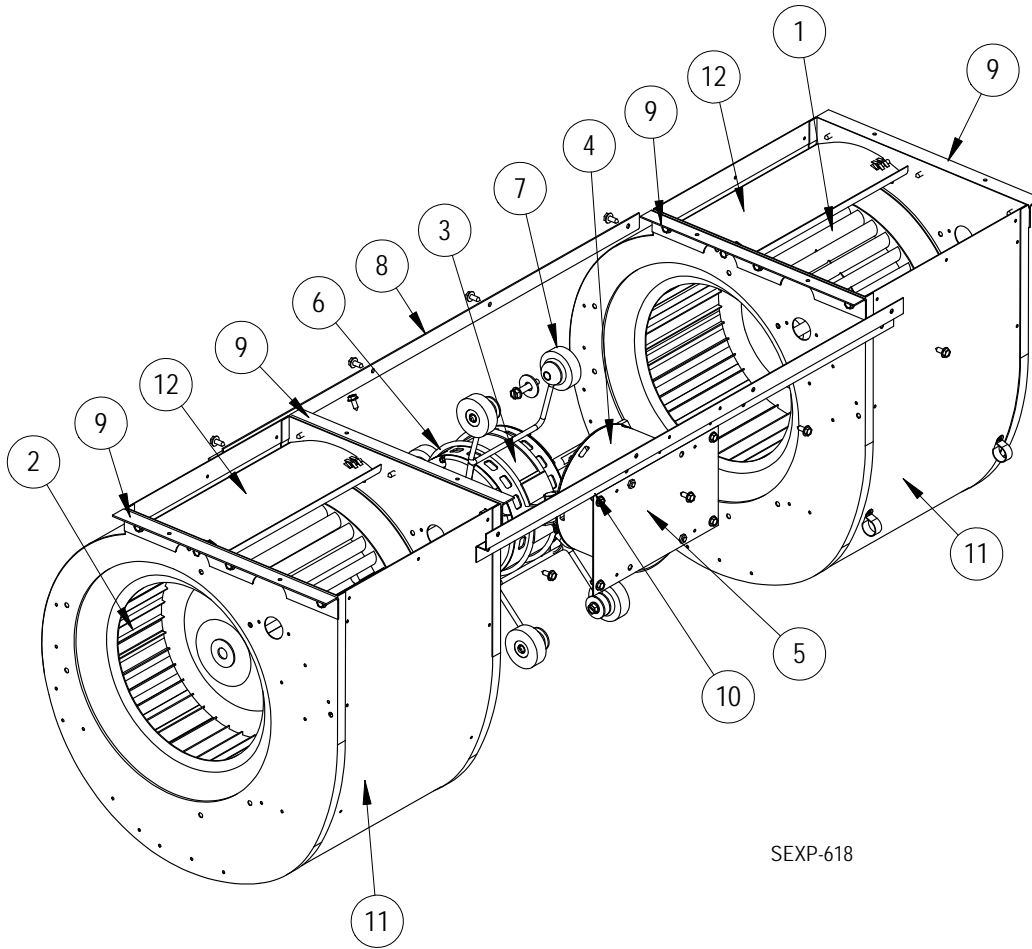

SEXP-618

Dwg. No.	Part Number	Description	S900-272-003	S900-273-005	S900-273-006
1	5152-011	10 Inch Wheel (CW)	X	X	X
2	5152-012	10 Inch Wheel (CW)	X	X	X
3	S8106-052-0065B	1/2 HP Programmed Motor	X		
3	S8107-017-0061	1/2 HP Programmed Motor		X	
3	S8107-017-0063B	3/4 HP Programmed Motor			X
4	C8106-052-0065B	Programmed Motor Control Only	X		
4	C8107-017-0061	Programmed Motor Control Only		X	
4	C8107-017-0063B	Programmed Motor Control Only			X
5	112-344	Blower Mount Control Bracket	X	X	X
6	8200-040	Motor Mount	X	X	X
7	5451-011	Grommets	6	6	6
8	105-881	Back Brace	X	X	X
9	105-880	Side Angle	4	4	4
10	103-389	Front Brace	X	X	X
11	151-101	Housing	2	2	2
12	144-166	Diffuser	2	2	2