REPLACEMENT PARTS MANUAL

WALL MOUNTED PACKAGE AIR CONDITIONER

Models:

H42LA-A H48LA-A H60LA-A

General Notes

- Revised and/or additional pages may be issued from time to time.
- A complete and current manual consists of pages shown in the following contents section.

Important

- Contact the installing and/or local Bard distributor for all parts requirements. Make sure to have the complete model and serial number available from the unit rating plates.

Contents

<u>Description</u>	<u>Page</u>
Cabinet Components	
♦ Exploded View	2
♦ Usage List	3
♦ Usage List	4
Functional Components	
♦ Exploded View	6
♦ Usage List	7
Control Panel	
♦ Layout View	8
♦ Usage List	9
Blower Assembly	
♦ Exploded View	10
♦ Usage List	10



Bard Manufacturing Company, Inc.
Bryan, Ohio 43506
www.bardhvac.com

Manual: 2110-1524
Supersedes: **NEW**
Date: 9-3-15

CABINET COMPONENTS

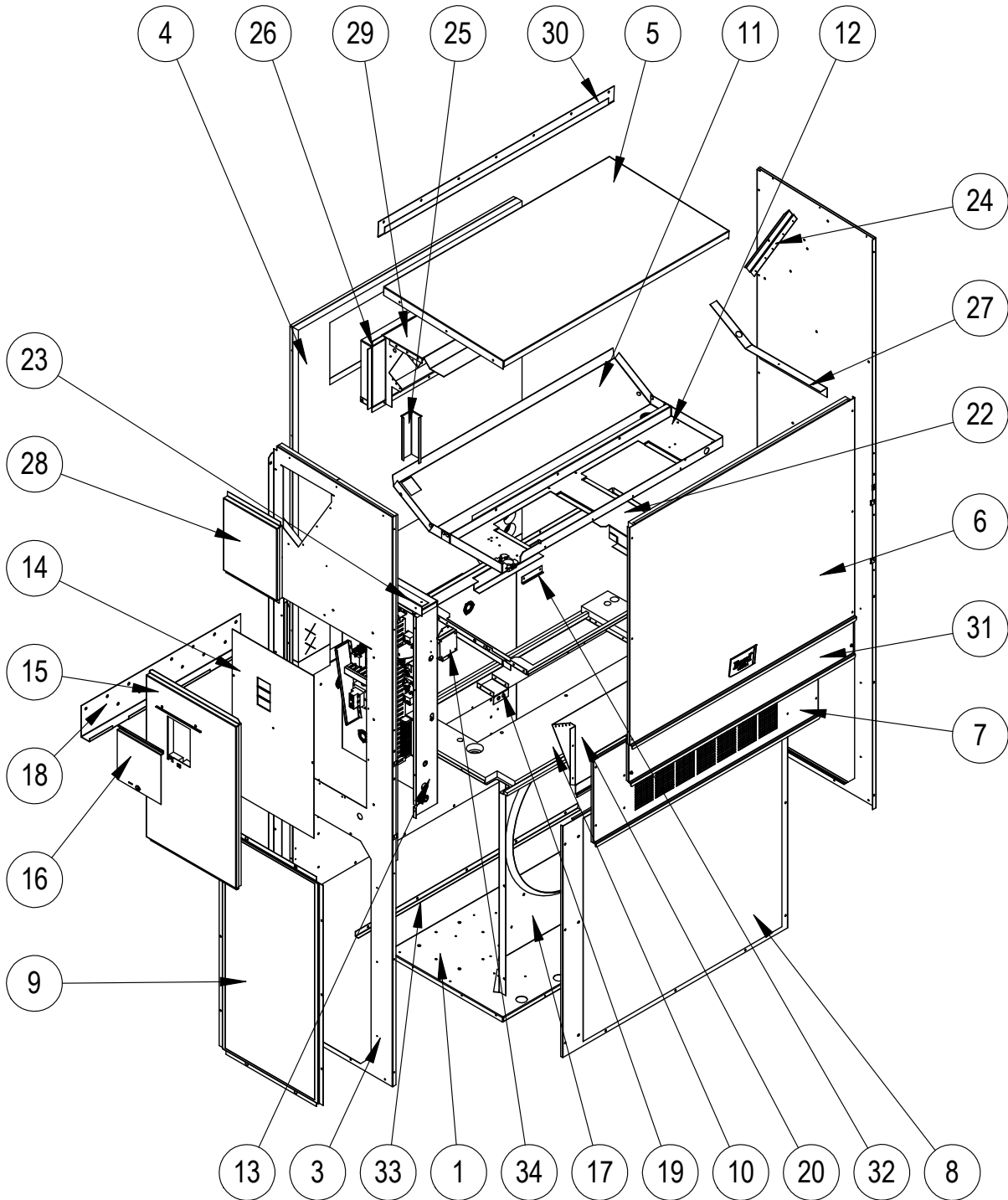

SEXP-821

This drawing is referenced in tables on pages 3 and 4

CABINET COMPONENTS

Dwg No.	Part Number	Description	H42LA-A	H48LA-A
1	S127-428	Lower Base	X	X
1	S127-436 ③	Lower Base	X	X
2	S501-687-* ①	Right Side	X	X
2	S501-713 ②	Right Side	X	X
2	S501-715 ③	Right Side	X	X
3	S501-842-* ①	Left Side	X	X
3	S501-927 ②	Left Side	X	X
3	S501-926 ③	Left Side	X	X
4	S508-098	Back	X	X
4	S508-275 ②	Back	X	X
4	S508-221 ③	Back	X	X
5	S507-307-* ①	Top	X	X
5	S507-309 ②	Top	X	X
5	S507-310 ③	Top	X	X
6	S515-230-* ①	Upper Front	X	X
6	S514-231 ②	Upper Front	X	X
6	S514-232 ③	Upper Front	X	X
7	S553-522-* ①	Vent Option Door	X	X
7	S553-525 ②	Vent Option Door	X	X
7	S553-527 ③	Vent Option Door	X	X
8	118-049-* ①	Condenser Grille	X	X
8	118-065 ②	Condenser Grille	X	X
8	118-074 ③	Condenser Grille	X	X
9	118-057-* ①	Side Grille	2	2
9	118-063 ②	Side Grille	2	2
9	118-073 ③	Side Grille	2	2
10	S521Y503	Condenser Partition	X	X
11	S123-121	Drain Pan	X	X
11	S123-137 ②③	Drain Pan	X	X
12	121Y463	Blower Partition	X	X
13	Control Panel Assy.	See Control Panel Assy. Drawing & Parts List	X	X
14	S133-277	Control Panel Cover (Inner)	X	X
15	S533-280-* ①	Control Panel Cover (Outer)	X	X
15	S533-275 ②	Control Panel Cover (Outer)	X	X
15	S533-276 ③	Control Panel Cover (Outer)	X	X
16	S153-218-* ①	Disconnect Access Door	X	X
16	S153-387 ②	Disconnect Access Door	X	X
16	S153-405 ③	Disconnect Access Door	X	X
17	125-024	Fan Shroud	X	X
17	125-058 ③	Fan Shroud	X	X
18	113-140	Bottom Mounting Bracket	X	X
19	113-600	Light Switch Bracket	X	X
20	BFAD-5	Fresh Air Damper Assembly	X	X
22	131Y099	Filter Tray	X	X
23	105Y878	Left Side Support	X	X
24	147-046	Left Evaporator Support	X	X
25	135-377	Raceway	2	2
26	S111Y034	Outlet Air Frame Assembly	X	X
27	105Y877	Right Side Support	X	X
28	S543-172-* ①	Right Side Cover Plate (Outer)	X	X
28	S543-176 ②	Right Side Cover Plate (Outer)	X	X
28	S543-177 ③	Right Side Cover Plate (Outer)	X	X
29	135-129	Heat Shield	X	X
30	113-150-* ①	Top Rain Flashing	X	X
30	113-359 ③	Top Rain Flashing	X	X
31	S553-521-* ①	Filter Door Assembly	X	X
31	S553-526 ②	Filter Door Assembly	X	X
31	S553-528 ③	Filter Door Assembly	X	X
32	105-1302	Grommet Retainer	X	X
33	105-1324	Close Off Angle	X	X
34	113-586	Switch Mounting Bracket	X	X
NS	S536-804	Cond. Partition Block Off Plate	X	X

① Exterior cabinet parts are manufactured with various paint color options. To insure the proper paint color is received, include the complete model and serial number of the unit for which cabinet parts are being ordered.

② Exterior cabinet parts are manufactured from aluminum Code "A"

③ Exterior cabinet parts are manufactured from stainless steel Code "S"

NS = Not Shown

CABINET COMPONENTS

Dwg No.	Part Number	Description	H60LA-A
1	S127-428	Lower Base	X
1	S127-436 ③	Lower Base	X
2	S501-912-* ①	Right Side	X
2	S501-932 ②	Right Side	X
2	S501-918 ③	Right Side	X
3	S501-843-* ①	Left Side	X
3	S501-930 ②	Left Side	X
3	S501-931 ③	Left Side	X
4	S508-251	Back	X
4	S508-252 ②	Back	X
4	S508-253 ③	Back	X
5	S507-307-* ①	Top	X
5	S507-309 ②	Top	X
5	S507-310 ③	Top	X
6	S515-246-* ①	Upper Front	X
6	S514-280 ②	Upper Front	X
6	S514-253 ③	Upper Front	X
7	S553-522-* ①	Vent Option Door	X
7	S553-525 ②	Vent Option Door	X
7	S553-527 ③	Vent Option Door	X
8	118-094-* ①	Condenser Grille	X
8	118-100 ②	Condenser Grille	X
8	118-099 ③	Condenser Grille	X
9	118-086-* ①	Side Grille	2
9	118-088 ②	Side Grille	2
9	118-090 ③	Side Grille	2
10	S521Y503	Condenser Partition	X
11	S123-121	Drain Pan	X
11	S123-137 ②③	Drain Pan	X
12	121Y463	Blower Partition	X
13	Control Panel Assy.	See Control Panel Assy. Drawing & Parts List	X
14	S133-277	Control Panel Cover (Inner)	X
15	S533-280-* ①	Control Panel Cover (Outer)	X
15	S533-275 ②	Control Panel Cover (Outer)	X
15	S533-276 ③	Control Panel Cover (Outer)	X
16	S153-218-* ①	Disconnect Access Door	X
16	S153-387 ②	Disconnect Access Door	X
16	S153-405 ③	Disconnect Access Door	X
17	125-070	Fan Shroud	X
17	125-064 ③	Fan Shroud	X
18	113-140	Bottom Mounting Bracket	X
19	113-600	Light Switch Bracket	X
22	131Y099	Filter Tray	X
23	105Y878	Left Side Support	X
24	147-046	Left Evaporator Support	X
25	135-377	Raceway	2
26	S111Y034	Outlet Air Frame Assembly	X
27	105Y877	Right Side Support	X
28	S543-172-* ①	Right Side Cover Plate (Outer)	X
28	S543-176 ②	Right Side Cover Plate (Outer)	X
28	S543-177 ③	Right Side Cover Plate (Outer)	X
29	135-129	Heat Shield	X
30	113-150-* ①	Top Rain Flashing	X
30	113-359 ③	Top Rain Flashing	X
31	S553-521-* ①	Filter Door Assembly	X
31	S553-526 ②	Filter Door Assembly	X
31	S553-528 ③	Filter Door Assembly	X
32	105-1302	Grommet Retainer	X
33	105-1324	Close Off Angle	X
34	113-586	Filter Switch Bracket	X
NS	S536-804	Cond. Partition Block Off Plate	X

① Exterior cabinet parts are manufactured with various paint color options. To insure the proper paint color is received, include the complete model and serial number of the unit for which cabinet parts are being ordered.

② Exterior cabinet parts are manufactured from aluminum Code "A"

③ Exterior cabinet parts are manufactured from stainless steel Code "S"

NS = Not Shown

This page intentionally left blank

FUNCTIONAL COMPONENTS

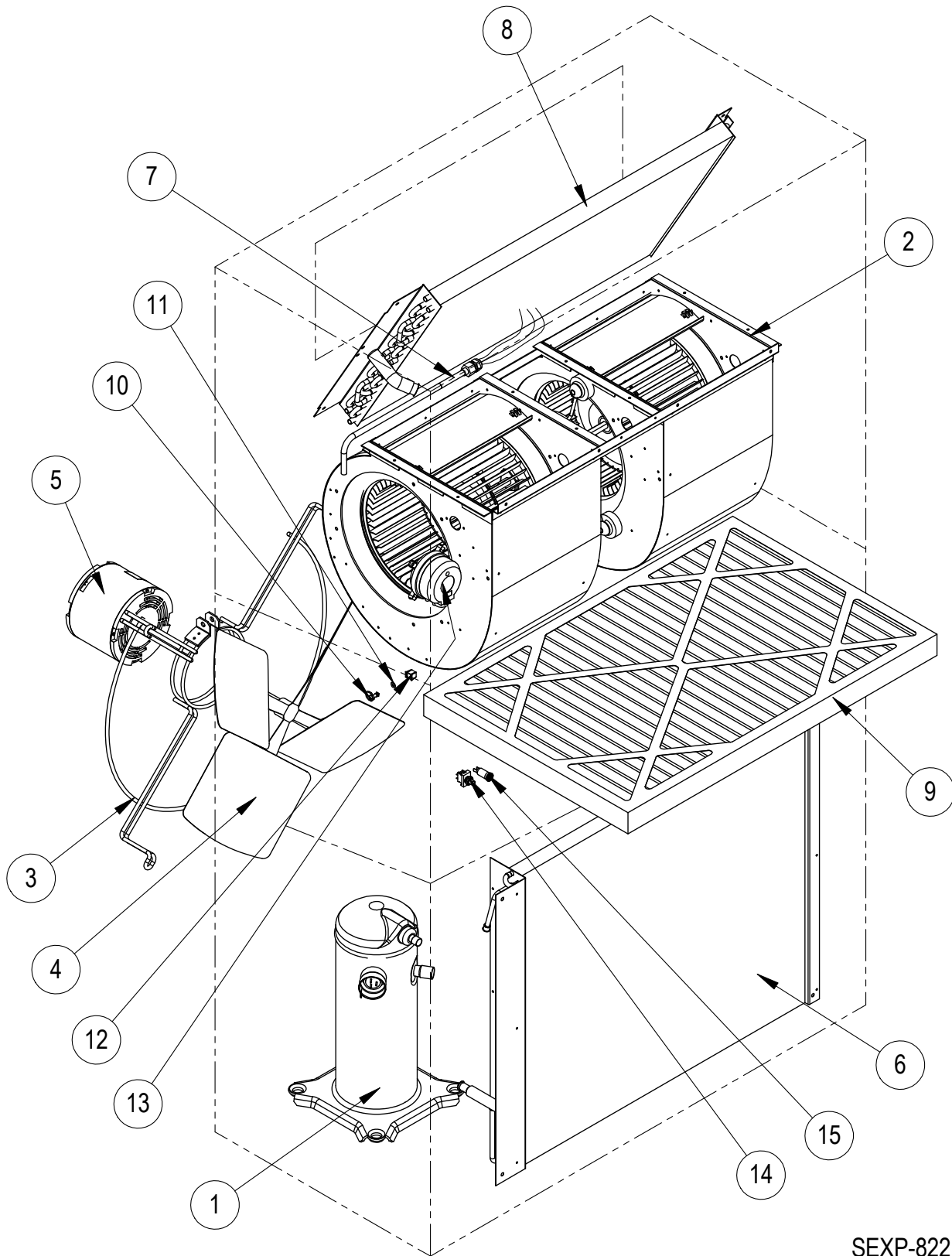

SEXP-822

FUNCTIONAL COMPONENTS

Dwg No.	Part Number	Description	H42LA-A	H48LA-A	H60LA-A
1	8000-349	Compressor	X		
1	8000-343	Compressor		X	
1	8000-415	Compressor			X
2	S900-320	Blower Assembly	X	X	
2	S900-185	Blower Assembly			X
3	8200-004	Fan Motor Mount	X	X	X
4	5151-060	Fan Blade	X	X	X
5	8105-066	Condenser Motor	X	X	X
6	5051-200BX	Condenser Coil	X		
6	5054-200BX	Condenser Coil - Coated	X		
6	5051-198BX	Condenser Coil			X
6	5054-198BX	Condenser Coil - Coated			X
6	5051-199BX	Condenser Coil		X	
6	5054-199BX	Condenser Coil - Coated		X	
7	800-0452	Distributor Assembly	X		
7	800-0451	Distributor Assembly		X	
7	800-0453	Distributor Assembly			X
8	917-0256BX	Evaporator Coil		X	
8	917-0266BX	Evaporator Coil - Coated		X	
8	917-0257BX	Evaporator Coil			X
8	917-0268BX	Evaporator Coil - Coated			X
8	917-0255BX	Evaporator Coil	X		
8	917-0265BX	Evaporator Coil - Coated	X		
9	7004-027	Air Filter 2" Pleated (20x30x2)	X	X	X
10	1171-022	1/4 Turn Fastener	X	X	X
11	1171-024	1/4 Turn Retainer	X	X	X
12	1171-023	1/4 Receptacle	X	X	X
13	8301-057	Filter Switch w/Adjustment	X	X	X
14	3000-1538	Switch Wire Harness	X	X	X
15	8611-094	Indicator Light	X	X	X
NS	5201-022	Filter Drier	X	X	X
NS	CMA-28	Low Ambient Control	X	X	X
NS	8406-142	High Pressure Switch	X	X	X
NS	8406-140	Low Pressure Switch	X	X	X
NS	5451-024	Tubing Isolation Grommet	2	2	2
NS	6031-009	Coremax Valve Core	2	2	2
NS	8620-113	Compressor Crankcase Heater			X
NS	1171-028	Filter Door Clip	2	2	2
NS	1171-057	Filter Door Screw	2	2	2
NS	1171-027	Filter Door Screw Retainer	2	2	2

NS = Not shown

CONTROL PANEL

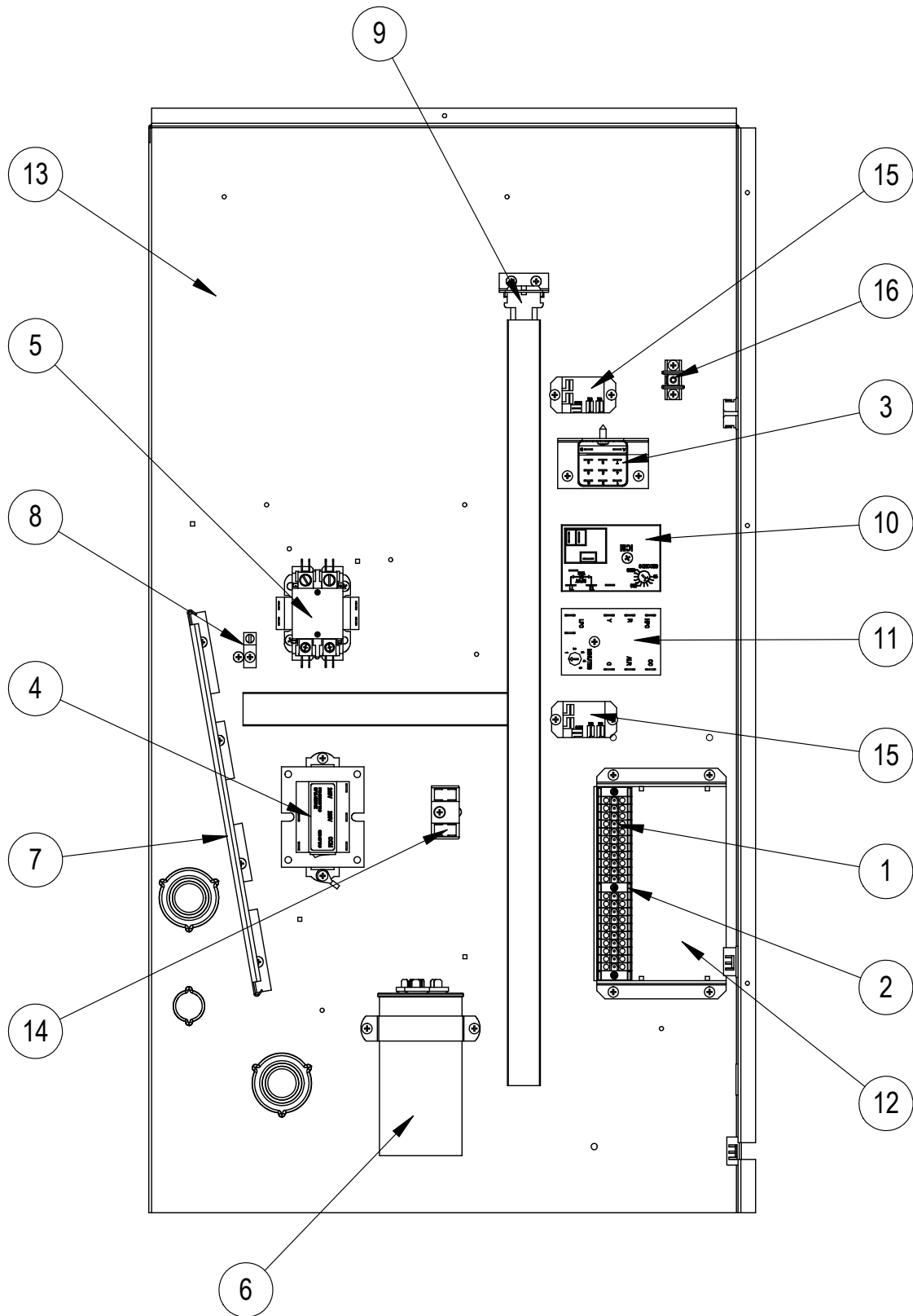

SEXP-823

CONTROL PANEL

Dwg No.	Part Number	Description	H42LA-A	H48LA-A	H60LA-A
1	8607-046	Terminal Block Section	X	X	X
2	8607-047	Terminal Strip Mount Section	X	X	X
3	8201-048	Dirty Filter Relay	X	X	X
4	8407-065	Transformer	X	X	X
5	8401-034	Compressor Contactor	X	X	X
6	8552-079	Compressor Capacitor	X		
6	8552-089	Compressor Capacitor		X	
6	8552-059	Compressor Capacitor			X
7	135-122	Wire Shield	X	X	X
8	8611-006	Ground Terminal	X	X	X
9	3000-1536	6 Pin Connector	X	X	X
10	8201-133	Time Delay Relay	X	X	X
11	8201-157	Compressor Control Module	X	X	X
12	117-383	Low Voltage Riser	X	X	X
13	117Y388	Control Panel	X	X	X
14	8607-017	Terminal Block	X	X	X
15	8201-130	Indoor Blower Relay	X	X	X
16	8607-041	Park Terminal	X	X	X
NS	8615-040	Circuit Breaker 50A 2 Pole ①	X	X	
NS	8615-041	Circuit Breaker 60A 2 Pole ①			X
NS	4095-191	Wiring Diagram	X	X	X
NS	3000-1222	Compressor Plug Wire Assembly	X	X	X
NS	3000-1516	Vent Wire Assembly – 12 Terminal	X	X	X

① Circuit breakers listed are for units without electric heat "OZ" models. See Heater Replacement Parts Manual for units with electric heat.

NS – Not shown

BLOWER ASSEMBLY

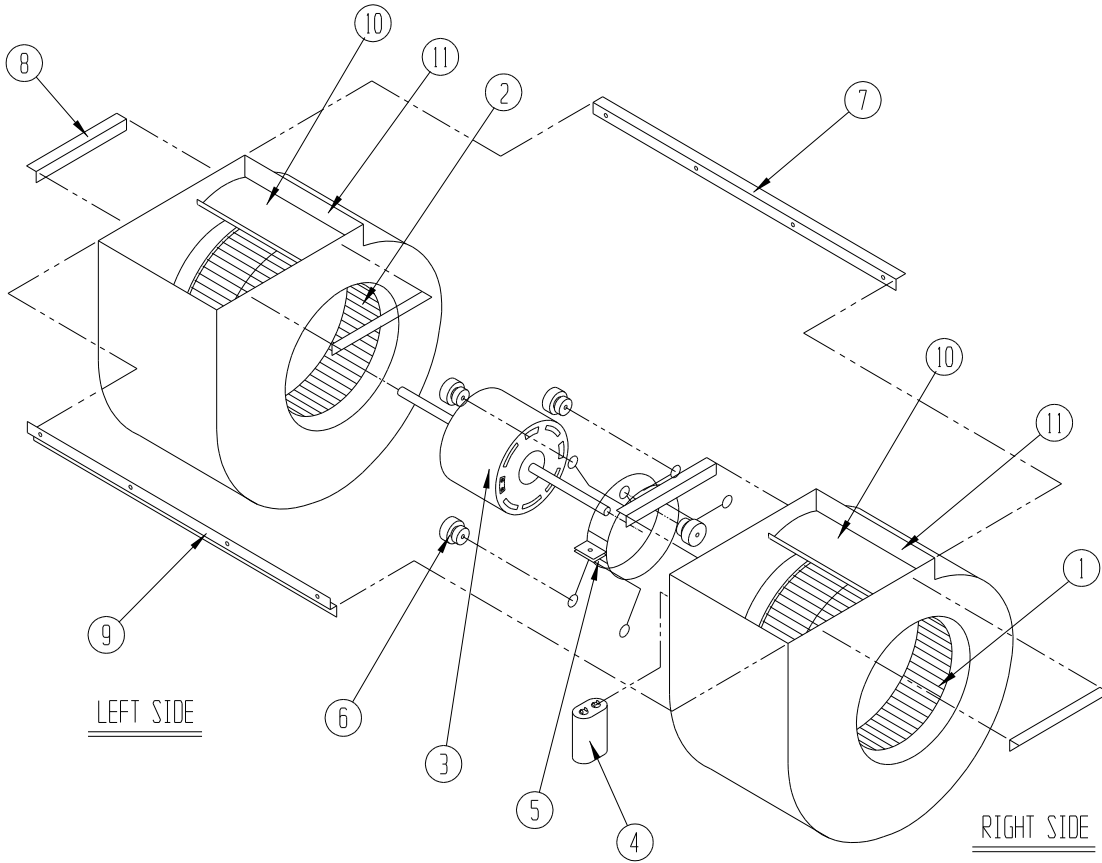

SEXP-178

Dwg No.	Part Number	Description	900-320	900-185
1	5152-011	10 Inch Wheel (CW)		X
1	5152-057	9 Inch Wheel (CW)	X	X
2	5152-012	10 Inch Wheel (CW)		X
2	5152-058	9 Inch Wheel (CW)	X	X
3	8105-061	Blower Motor (230/208)	X	
3	8106-046	Blower Motor (230/208)		X
4	8552-091	Capacitor	X	X
5	8200-040	Motor Mount	X	X
6	5451-011	Grommets	6	6
7	105-881	Back Brace	X	X
8	105-880	Side Angle	4	4
9	103-389	Front Brace	X	X
10	151-101	Housing	2	2
11	144-166	Diffuser	2	2