REPLACEMENT PARTS MANUAL

WALL MOUNTED PACKAGED AIR CONDITIONER

Model:
H12AA-A

General Notes

- Revised and/or additional pages may be issued from time to time.
- A complete and current manual consists of pages shown in the following contents section.

Important

- Contact the installing and/or local Bard distributor for all parts requirements. Make sure to have the complete model and serial number available from the unit rating plates.

Contents

<u>Description</u>	<u>Page</u>
Cabinet Components	
♦ Exploded View.....	2
♦ Usage List	3
Functional Components	
♦ Exploded View.....	4
♦ Usage List	5
Control Panel (Circuit Breaker Option)	
♦ Layout View	6
♦ Usage List	7
Blower Assembly	
♦ Exploded View.....	8
♦ Usage List	8



Bard Manufacturing Company, Inc.
Bryan, Ohio 43506
www.bardhvac.com

Manual: 2110-1525A
Supersedes: 2110-1525
Date: 5-25-18

CABINET COMPONENTS

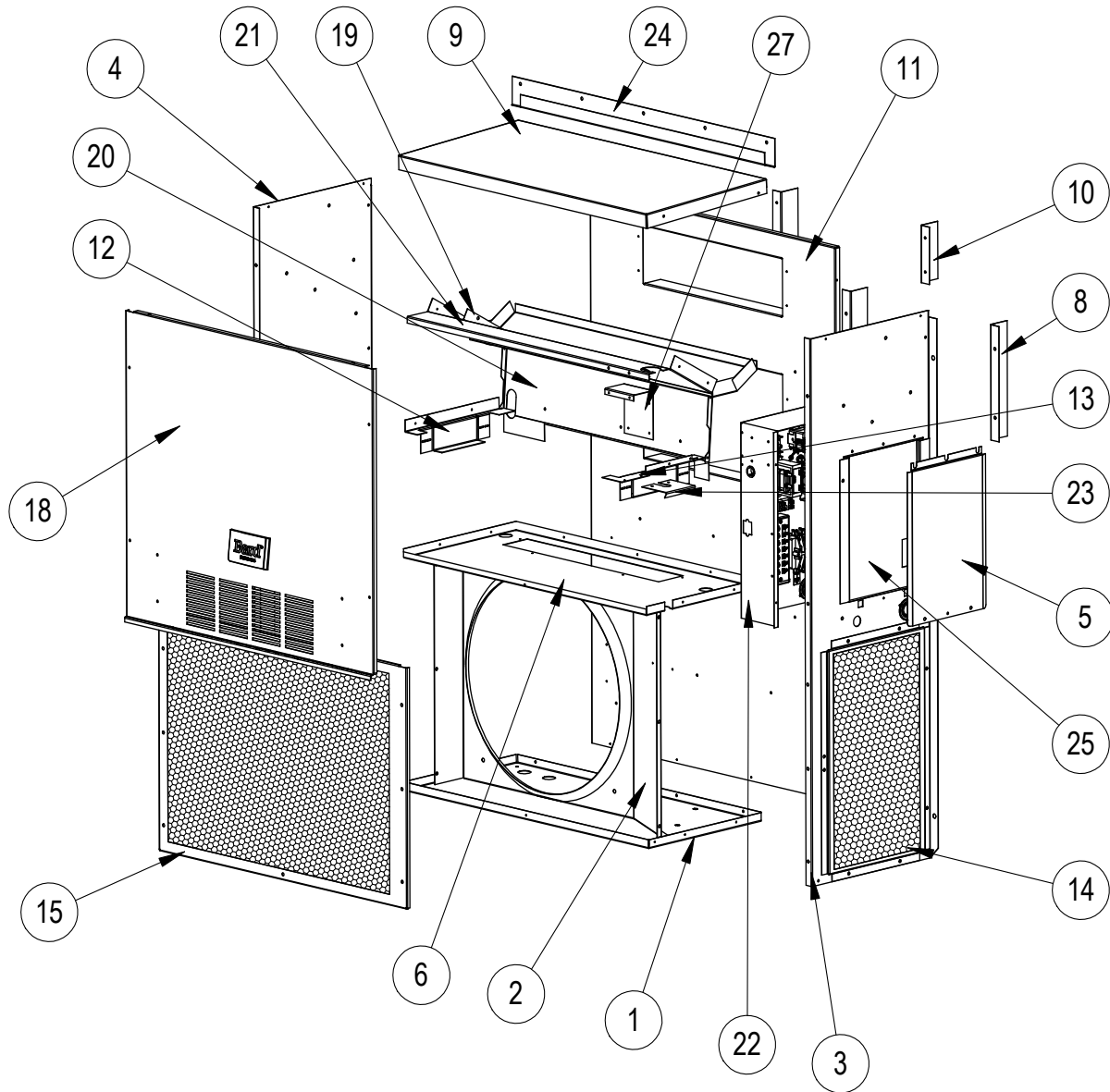

SEXP-836

CABINET COMPONENTS

Drawing No.	Part No.	Description	H12AA-A
1	S127-491	Lower Base	X
2	125-071	Fan Shroud	X
3	S501-867-* ①	Right Side	X
3	S501-901-* ①②	Right Side	X
4	S501-868-* ①	Left Side	X
4	S501-902-* ①②	Left Side	X
5	S133-264-* ①	Control Panel Cover (Outer)	X
6	520-243	Condenser Partition	X
6	520-525 ②	Condenser Partition	X
8	111-214	Return Air Frame Angle	2
9	506-148-* ①	Top	X
9	506-361-* ①②	Top	X
10	111-036	Outlet Air Frame Angle	2
11	509-325	Back	X
11	509-333 ②	Back	X
12	113-529	Left Filter Bracket	X
13	113-532	Right Filter Bracket	X
14	118-095-* ①	Side Grille	2
15	118-096-* ①	Condenser Grille	X
18	S514-295-* ①	Upper Front	X
18	S514-299-* ①②	Upper Front	X
19	113-176	Heater Bracket	X
20	121-504	Return Partition	X
21	S121-505	Drain Pan	X
22	Control Panel Assembly	See Control Panel Assembly Drawing and Parts List	X
23	135-138	Fill Plate	X
24	113-178-* ①	Top Rain Flashing	X
25	133-263-* ①	Control Panel Cover (Inner)	X
26	110-214	Return Flange	X
27	113-604	Filter Switch Bracket	X

① *Exterior cabinet parts are manufactured with various paint color options. To ensure the proper paint color is received, include the complete model and serial number of the unit for which cabinet parts are being ordered.*

② *Nonfiberglass insulation option*

FUNCTIONAL COMPONENTS

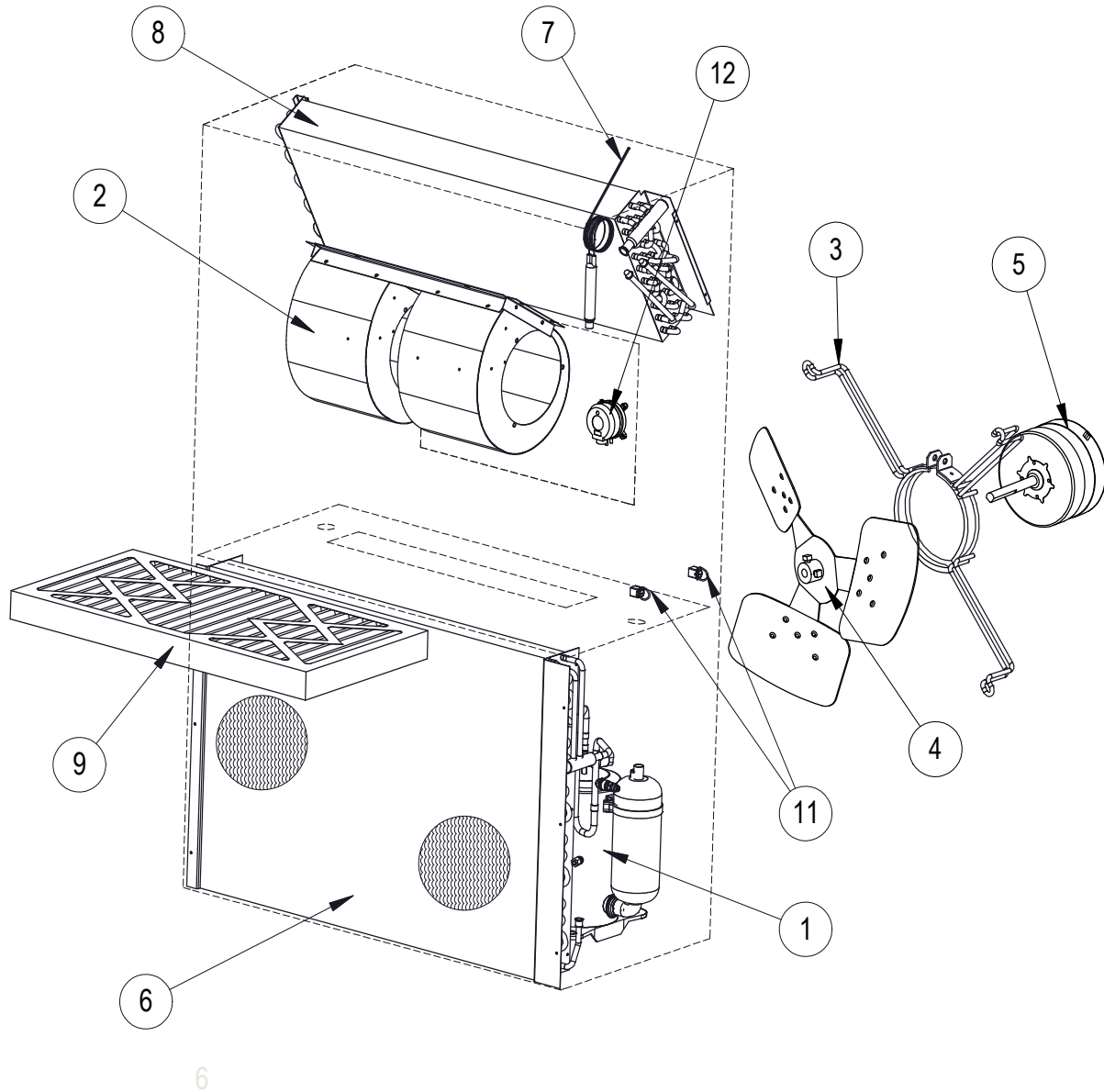

SEXP-837

FUNCTIONAL COMPONENTS

Drawing No.	Part No.	Description	H12AA-A
1	8000-406	Compressor	X
2	900-343	Blower Assembly 240V	X
3	8200-001	Fan Motor Mount	X
4	5151-059	Fan Blade	X
5	8101-026	Condenser Motor 240V	X
6	5051-194BX	Condenser Coil	X
7	800-0442	Cooling Capillary Assembly	X
8	5060-193BX	Evaporator Coil	X
9	7003-073	Air Filter 1" Washable	X
9	7004-056	Air Filter 1" Throw Away	X
9	7004-057	Air Filter 2" Pleated ①	X
11	1171-066	#82 1/4 Turn Fastener	X
11	1171-065	#82 Receptacle	X
11	1171-064	Retainer Clip	X
12	8301-057	Filter Switch w/Adjustment	X
NS	8406-113	High Pressure Switch	X
NS	8406-147	Low Pressure Switch	X
NS	CMA-28	Low Ambient Control Service Kit (Flare) ①	X
NS	8402-185	Compressor Overload	X
NS	5201-021	Filter Drier	X
NS	6031-009	Coremax Valve Core	X

NS – Not Shown

① – Optional on these models

CONTROL PANEL (CIRCUIT BREAKER OPTION)

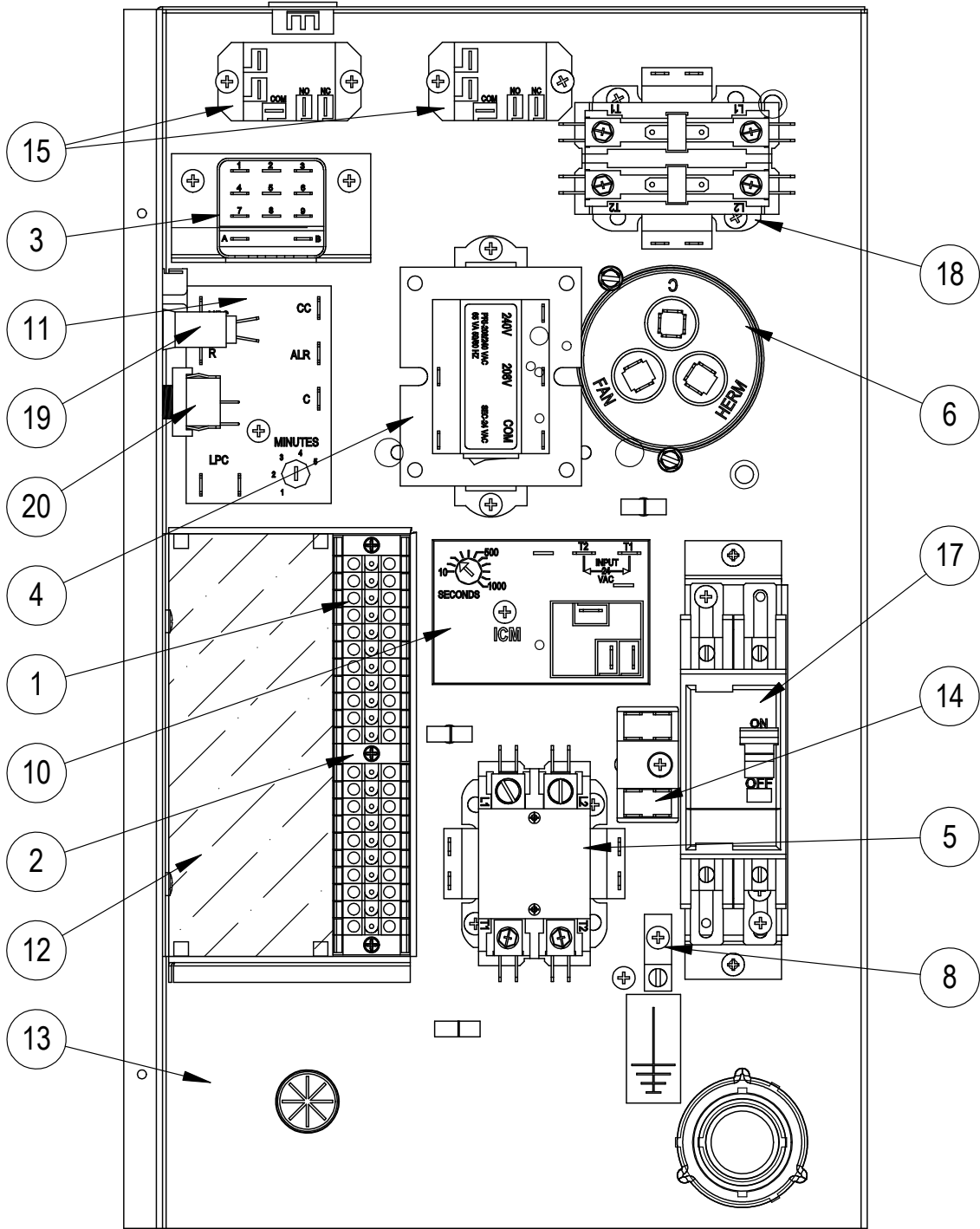

SEXP-835

CONTROL PANEL (CIRCUIT BREAKER OPTION)

Dwg No.	Part Number	Description	H12AA-A0Z	H12AA-A03	H12AA-A05
1	8607-046	Terminal Block Section	X	X	X
2	8607-047	Terminal Strip Mount Section	X	X	X
3	8201-048	Dirty Filter Relay	X	X	X
4	8407-068	Transformer	X	X	X
5	8401-033	Compressor Contactor	X	X	X
6	8552-050	Compressor Capacitor	X	X	X
8	8611-006	Ground Terminal	X	X	X
10	8201-133	Time Delay Relay	X	X	X
11	8201-164	Compressor Control Module	X	X	X
12	117-390	Low Voltage Riser	X	X	X
13	117X381	Control Panel	X	X	X
14	8607-017	Terminal Block	X	X	X
15	8201-130	Indoor Blower Relay	X	X	X
16	8607-041	Park Terminal	X	X	X
17	8615-037	Circuit Breaker 50A 2 Pole			X
17	8615-060	Circuit Breaker 60A 2 Pole	X	X	
18	8401-006	Heater Contactor		X	X
19	8611-094	Light (Indicator)	X	X	X
20	3000-1540	Switch Harness	X	X	X
NS	4095-193	Wiring Diagram	X		
NS	4095-194	Wiring Diagram		X	X

NS – Not shown

BLOWER ASSEMBLY

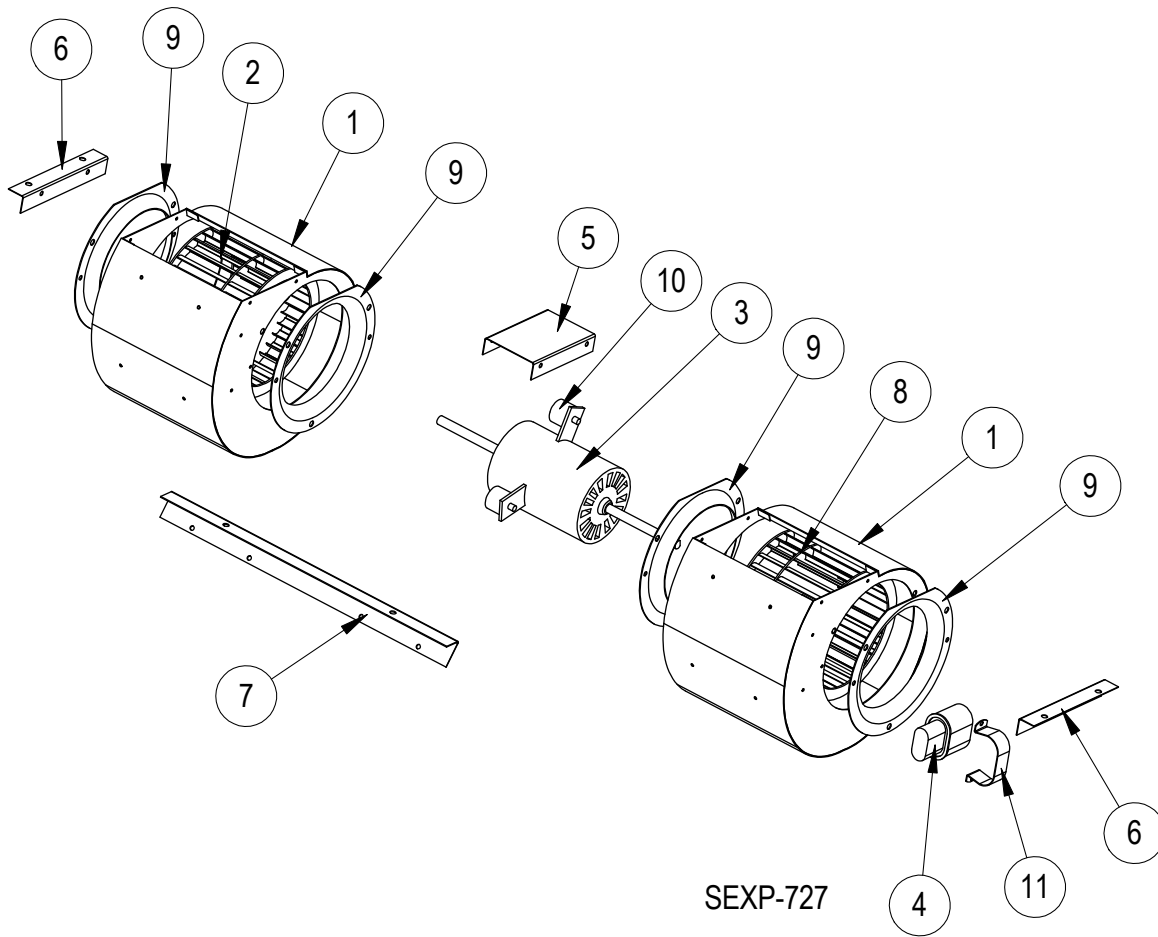

Drawing No.	Part No.	Description	900-343
1	151-114	Blower Housing *	X
2	5152-085	Wheel (CCW) Left	X
3	8101-028	Blower Motor (230/208)	X
4	8552-001	Capacitor 4MFD	X
5	141-429	Center Blower Support	X
6	105-908	Side Angle	2
7	105-1355	Front Brace	X
8	5152-084	Wheel (CW) Right	X
9	144-180	Inlet Ring	4
10	5451-018	Mounting Grommet	3
11	8550-003	Capacitor Bracket	4

* Replace with new rings