

---

# REPLACEMENT PARTS MANUAL

---

## WALL-MOUNTED PACKAGED AIR CONDITIONER

### Models:

H24AA-A H36AA-A  
H24LA-A H36LA-A

---

Description	Page
Cabinet Components – H24AA-A, H36AA-A	
♦ Exploded View .....	2
♦ Usage List – H24AA-A .....	3
♦ Usage List – H36AA-A .....	4
Cabinet Components – H24LA-A, H36LA-A	
♦ Exploded View .....	6
♦ Usage List – H24LA-A .....	7
♦ Usage List – H36LA-A .....	8
Functional Components	
♦ Exploded View .....	10
♦ Usage List .....	11
Blower Assembly	
♦ Exploded View/Usage List .....	12
Control Panel	
♦ Layout View – H24AA-A, H36AA-A .....	14
♦ Layout View – H24LA-A, H36LA-A .....	15
♦ Usage List .....	16

### General Notes

- Revised and/or additional pages may be issued from time to time.
- A complete and current manual consists of pages shown in the following contents section.

### Important

- Contact the installing and/or local Bard distributor for all parts requirements. Make sure to have the complete model and serial number available from the unit rating plates.



*Climate Control Solutions*

Bard Manufacturing Company, Inc.  
Bryan, Ohio 43506  
www.bardhvac.com

Manual: 2110-1527A  
Supersedes: 2110-1527  
Date: 11-14-17

# CABINET COMPONENTS - H24AA-A, H36AA-A

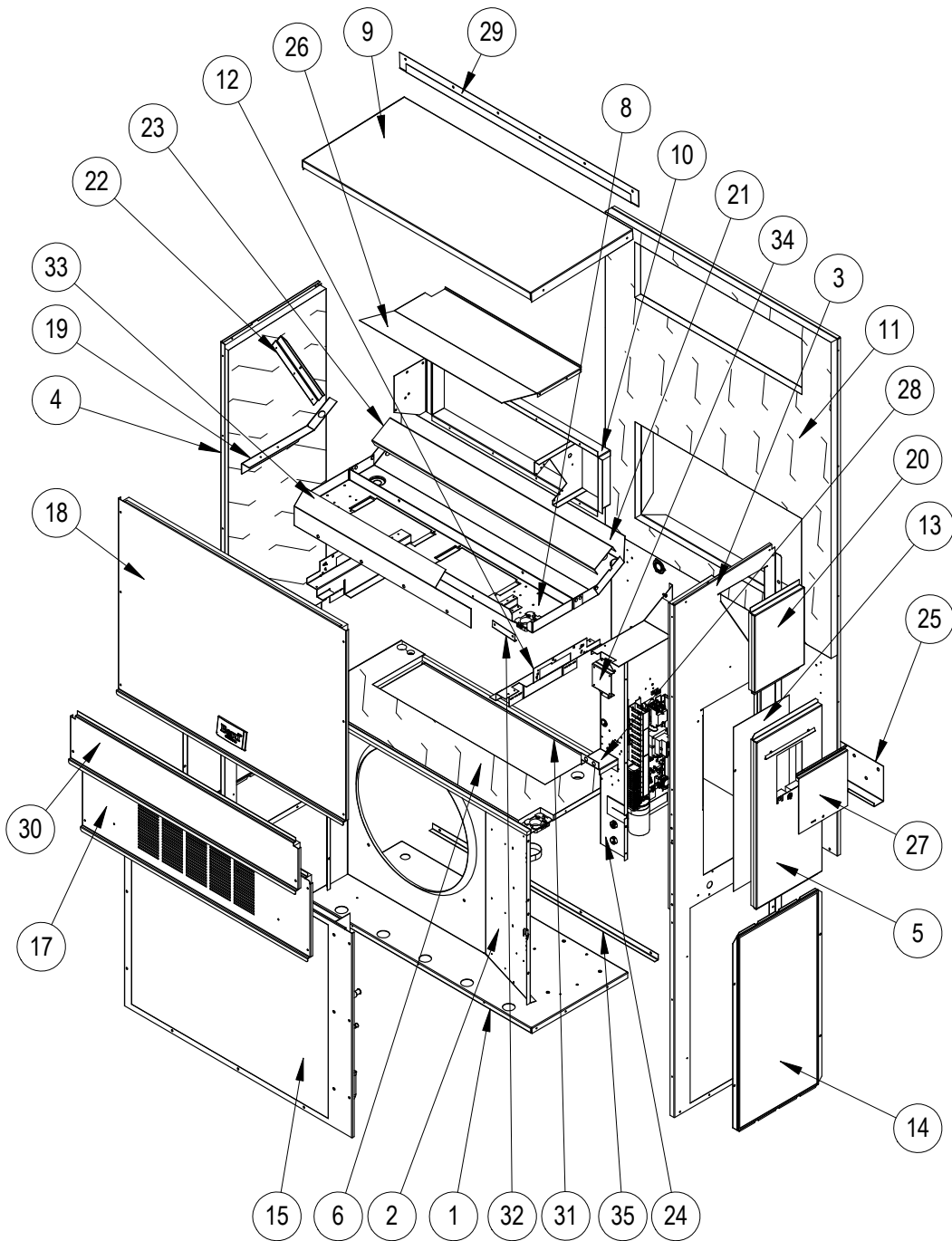

SEXP-838

This drawing to be used for reference for pages 3 and 4

## CABINET COMPONENTS - H24AA-A

Dwg No.	Part Number	Description
1	S127-467	Lower Base
1	S127-534 ②	Lower Base
2	125-080	Fan Shroud
2	125-082 ②	Fan Shroud
3	S501-933-* ①	Right Side
3	S501-994 ②	Right Side
3	S501-937 ③	Right Side
4	S501-934-* ①	Left Side
4	S501-995 ②	Left Side
4	S501-940 ③	Left Side
5	S533-228-* ①	Control Panel Cover (Outer)
5	S533-235 ②	Control Panel Cover (Outer)
5	S533-236 ③	Control Panel Cover (Outer)
6	S521X528	Condenser Partition
6	S521-553 ②	Condenser Partition
8	121X480	Blower Partition
9	S507-311-* ①	Top
9	S507-317 ②	Top
9	S507-318 ③	Top
10	S111X032	Outlet Air Frame Assembly
11	S508-342	Back
11	S508-344 ③	Back
11	S508-391 ②	Back
12	113X480	Filter Bracket (2 per unit)
13	S132-104	Control Panel Cover (Inner)
14	118-105-* ①	Side Grille (2 per unit)
14	118-110 ②	Side Grille (2 per unit)
14	118-115 ③	Side Grille (2 per unit)
15	118-101-* ①	Condenser Grille
15	118-106 ②	Condenser Grille
15	118-111 ③	Condenser Grille
17	S553-537-* ①	Vent Option Door
17	S553-539-* ①	Vent Option Door with ERV
17	S553-547 ②	Vent Option Door
17	S553-548 ③	Vent Option Door
18	S514-240-* ①	Upper Front
18	S514-236 ②	Upper Front
18	S514-237 ③	Upper Front
19	105X850	Side Support
20	S543-175-* ①	Right Side Cover Plate (Outer)
20	S543-185 ②	Right Side Cover Plate (Outer)
20	S543-184 ③	Right Side Cover Plate (Outer)
21	S123-126	Drain Pan
21	S123-140 ②	Drain Pan
22	147-044	Evaporator Support
23	137-694	Bottom Evaporator Fill
24	Control Panel Assembly	See Control Panel Assy. Drawing & Parts List Assy.
25	113-140	Bottom Mounting Bracket
26	135X127	Heat Shield
27	S153-218-* ①	Disconnect Access Door
27	S153-405 ②	Disconnect Access Door
27	S153-387 ③	Disconnect Access Door
28	113-606	Light Reset Bracket
29	113-141-* ①	Top Rain Flashing
29	113-361 ②	Top Rain Flashing
30	S553-538-* ①	Filter Door
30	S553-551 ②	Filter Door
30	S553-552 ③	Filter Door
31	S536-176	Cond. Partition Block Off Plate
31	S536-878 ②	Cond. Partition Block Off Plate
32	105-1302	Grommet Retainer
34	113-586	Pressure Switch Mounting Bracket
35	105-1392	Close Off Angle

① Exterior cabinet parts are manufactured with various paint color options. To ensure the proper paint color is received, reference the following codes:

Beige -X      Buckeye Gray -4      Dark Bronze -8  
 White -1      Desert Brown -5

② Exterior cabinet parts are manufactured from stainless steel Code "S"

③ Exterior cabinet parts are manufactured from aluminum Code "A"

# CABINET COMPONENTS – H36AA-A

Dwg No.	Part Number	Description
1	S127-471	Lower Base
1	S127-528 ②	Lower Base
2	125-081	Fan Shroud
2	125-083 ②	Fan Shroud
3	S501-933-* ①	Right Side
3	S501-994 ②	Right Side
3	S501-937 ③	Right Side
4	S501-934-* ①	Left Side
4	S501-995 ②	Left Side
4	S501-940 ③	Left Side
5	S533-228-* ①	Control Panel Cover (Outer)
5	S533-235 ②	Control Panel Cover (Outer)
5	S533-236 ③	Control Panel Cover (Outer)
6	S521X527	Condenser Partition
6	S521-552 ②	Condenser Partition
8	121X467	Blower Partition
9	S507-308-* ①	Top
9	S507-319 ②	Top
9	S507-320 ③	Top
10	S111X247	Outlet Air Frame Assembly
11	S508-343	Back
11	S508-388 ②	Back
11	S509-345 ③	Back
12	113X480	Filter Bracket (2 per unit)
13	S132-104	Control Panel Cover (Inner)
14	118-105-* ①	Side Grille (2 per unit)
14	118-110 ①	Side Grille (2 per unit)
14	118-115 ③	Side Grille (2 per unit)
15	118-103-* ①	Condenser Grille
15	118-108 ①	Condenser Grille
15	118-113 ③	Condenser Grille
17	S553-523-* ①	Vent Option Door
17	S553-540-* ①	Vent Option Door with ERV
17	S553-549 ②	Vent Option Door
17	S553-550 ③	Vent Option Door
18	S514-241-* ①	Upper Front
18	S514-238 ②	Upper Front
18	S514-239 ③	Upper Front
19	105X850	Side Support
20	S543-175-* ①	Right Side Cover Plate (Outer)
20	S543-185 ②	Right Side Cover Plate (Outer)
20	S543-184 ③	Right Side Cover Plate (Outer)
21	S123-127	Drain Pan
21	S123-141 ①	Drain Pan
22	147-044	Evaporator Support
23	137-685	Bottom Evaporator Fill
24	Control Panel Assembly	See Control Panel Assy. Drawing & Parts List Assy.
25	113-140	Bottom Mounting Bracket
26	135X123	Heat Shield
27	S153-218-* ①	Disconnect Access Door
27	S153-405 ②	Disconnect Access Door
27	S153-387 ③	Disconnect Access Door
28	113-606	Light Reset Bracket
29	113-149-* ①	Top Rain Flashing
29	113-360 ②	Top Rain Flashing
30	S553-524-* ①	Filter Door
30	S553-553 ②	Filter Door
30	S553-554 ③	Filter Door
31	S536-498	Cond. Partition Block Off Plate
31	S536-877 ②	Cond. Partition Block Off Plate
32	105-1302	Grommet Retainer
33	135-329	Air Baffle
34	113-586	Pressure Switch Mounting Bracket
35	104-1393	Close Off Angle

① Exterior cabinet parts are manufactured with various paint color options. To ensure the proper paint color is received, reference the following codes:

Beige -X    Buckeye Gray -4    Dark Bronze -8  
White -1    Desert Brown -5

② Exterior cabinet parts are manufactured from stainless steel Code "S"

③ Exterior cabinet parts are manufactured from aluminum Code "A"

Refer to drawing on page 2

*This page intentionally left blank*

# CABINET COMPONENTS - H24LA-A, H36LA-A

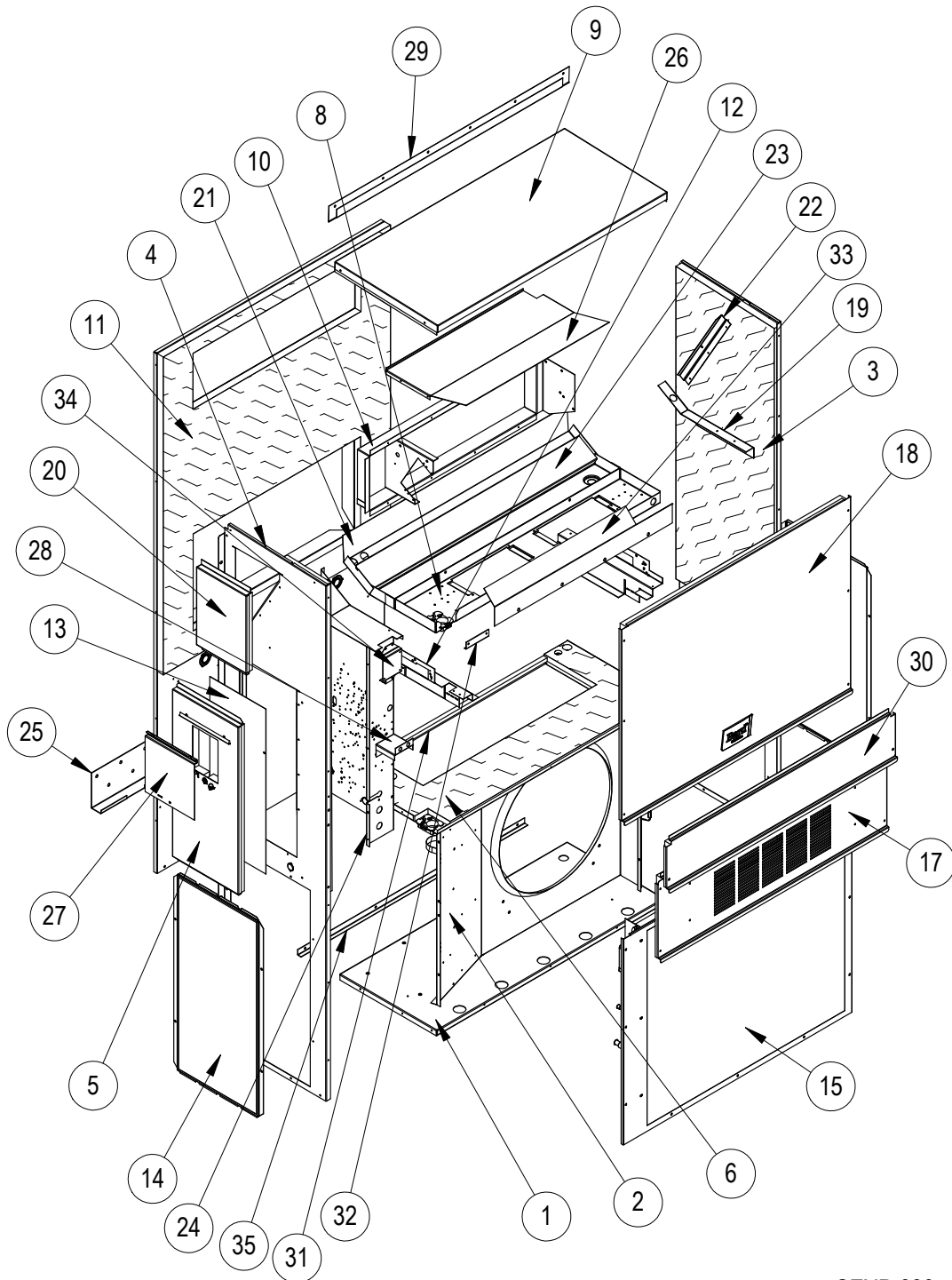

SEXP-839

This drawing to be used for reference for pages 7 and 8

## CABINET COMPONENTS – H24LA-A

Dwg No.	Part Number	Description
1	S127-468	Lower Base
1	S127-537 ②	Lower Base
2	125-080	Fan Shroud
2	125-082 ②	Fan Shroud
3	S501-935-* ①	Right Side
3	S501-998 ②	Right Side
3	S501-943 ③	Right Side
4	S501-936-* ①	Left Side
4	S501-999 ②	Left Side
4	S501-946 ③	Left Side
5	S533-228-* ①	Control Panel Cover (Outer)
5	S533-235 ②	Control Panel Cover (Outer)
5	S533-236 ③	Control Panel Cover (Outer)
6	S521Y528	Condenser Partition
6	S521-562 ②	Condenser Partition
8	121Y480	Blower Partition
9	S507-311-* ①	Top
9	S507-317 ②	Top
9	S507-318 ③	Top
10	S111Y032	Outlet Air Frame Assembly
11	S508-342	Back
11	S508-391 ②	Back
11	S508-344 ③	Back
12	113Y480	Filter Bracket (2 per unit)
13	S132-104	Control Panel Cover (Inner)
14	118-105-* ①	Side Grille (2 per unit)
14	118-110 ②	Side Grille (2 per unit)
14	118-115 ③	Side Grille (2 per unit)
15	118-102-* ①	Condenser Grille
15	118-107 ②	Condenser Grille
15	118-112 ③	Condenser Grille
17	S553-537-* ①	Vent Option Door
17	S553-547 ②	Vent Option Door
17	S553-548 ③	Vent Option Door
18	S514-240-* ①	Upper Front
18	S514-236 ②	Upper Front
18	S514-237 ③	Upper Front
19	105Y850	Side Support
20	S543-175-* ①	Right Side Cover Plate (Outer)
20	S543-185 ②	Right Side Cover Plate (Outer)
20	S543-184 ③	Right Side Cover Plate (Outer)
21	S123-131	Drain Pan
21	S123-142 ①	Drain Pan
22	147-044	Evaporator Support
23	137-694	Bottom Evaporator Fill
24	Control Panel Assembly	See Control Panel Assy. Drawing & Parts List Assy.
25	113-140	Bottom Mounting Bracket
26	135Y127	Heat Shield
27	S153-218-* ①	Disconnect Access Door
27	S153-405 ②	Disconnect Access Door
27	S153-387 ③	Disconnect Access Door
28	113-606	Light Reset Bracket
29	113-141-* ①	Top Rain Flashing
29	113-361 ②	Top Rain Flashing
30	S553-538-* ①	Filter Door
30	S553-551 ②	Filter Door
30	S553-552 ③	Filter Door
31	S536-176	Cond. Partition Block Off Plate
31	S536-878 ②	Cond. Partition Block Off Plate
32	105-1302	Grommet Retainer
34	113-586	Pressure Switch Mounting Bracket
35	105-1392	Close Off Angle

① Exterior cabinet parts are manufactured with various paint color options. To ensure the proper paint color is received, reference the following codes:

Beige -X    Buckeye Gray -4    Dark Bronze -8  
 White -1    Desert Brown -5

② Exterior cabinet parts are manufactured from stainless steel Code "S"

③ Exterior cabinet parts are manufactured from aluminum Code "A"

## CABINET COMPONENTS – H36LA-A

Dwg No.	Part Number	Description
1	S127-472	Lower Base
1	S127-533 ②	Lower Base
2	125-081	Fan Shroud
2	125-083 ②	Fan Shroud
3	S501-935-* ①	Right Side
3	S501-998 ②	Right Side
3	S501-943 ③	Right Side
4	S501-936-* ①	Left Side
4	S501-999 ②	Left Side
4	S501-946 ③	Left Side
5	S533-228-* ①	Control Panel Cover (Outer)
5	S533-235 ②	Control Panel Cover (Outer)
5	S533-236 ③	Control Panel Cover (Outer)
6	S521Y527	Condenser Partition
6	S521-561 ②	Condenser Partition
8	121Y467	Blower Partition
9	S507-308-* ①	Top
9	S507-319 ②	Top
9	S507-320 ③	Top
10	S111Y247	Outlet Air Frame Assembly
11	S508-343	Back
11	S508-388 ②	Back
11	S508-345 ③	Back
12	113Y480	Filter Bracket
13	S132-104	Control Panel Cover (Inner)
14	118-105-* ①	Side Grille
14	118-110 ②	Side Grille
14	118-115 ③	Side Grille
15	118-104-* ①	Condenser Grille
15	118-109 ②	Condenser Grille
15	118-114 ③	Condenser Grille
17	S553-523-* ①	Vent Option Door
17	S553-549 ②	Vent Option Door
17	S553-550 ③	Vent Option Door
18	S514-241-* ①	Upper Front
18	S514-238 ②	Upper Front
18	S514-239 ③	Upper Front
19	105Y850	Side Support
20	S543-175-* ①	Right Side Cover Plate (Outer)
20	S543-185 ②	Right Side Cover Plate (Outer)
20	S543-184 ③	Right Side Cover Plate (Outer)
21	S123-130	Drain Pan
21	S123-143 ①	Drain Pan
22	147-044	Evaporator Support
23	137-685	Bottom Evaporator Fill
24	Control Panel Assembly	See Control Panel Assy. Drawing & Parts List Assy.
25	113-140	Bottom Mounting Bracket
26	135Y123	Heat Shield
27	S153-218-* ①	Disconnect Access Door
27	S153-405 ②	Disconnect Access Door
27	S153-387	Disconnect Access Door
28	113-606	Light Reset Bracket
29	113-149-* ①	Top Rain Flashing
29	113-360 ②	Top Rain Flashing
30	S553-524-* ①	Filter Door
30	S553-553 ②	Filter Door
30	S553-554 ③	Filter Door
31	S536-498	Cond. Partition Block Off Plate
31	S536-877 ②	Cond. Partition Block Off Plate
32	105-1302	Grommet Retainer
33	135-329	Air Baffle
34	113-586	Pressure Switch Mounting Bracket
35	105-1393	Close Off Angle

① Exterior cabinet parts are manufactured with various paint color options. To ensure the proper paint color is received, reference the following codes:

Beige -X    Buckeye Gray -4    Dark Bronze -8  
 White -1    Desert Brown -5

② Exterior cabinet parts are manufactured from stainless steel Code "S"

③ Exterior cabinet parts are manufactured from aluminum Code "A"

Refer to drawing on page 6



*This page intentionally left blank*

# FUNCTIONAL COMPONENTS

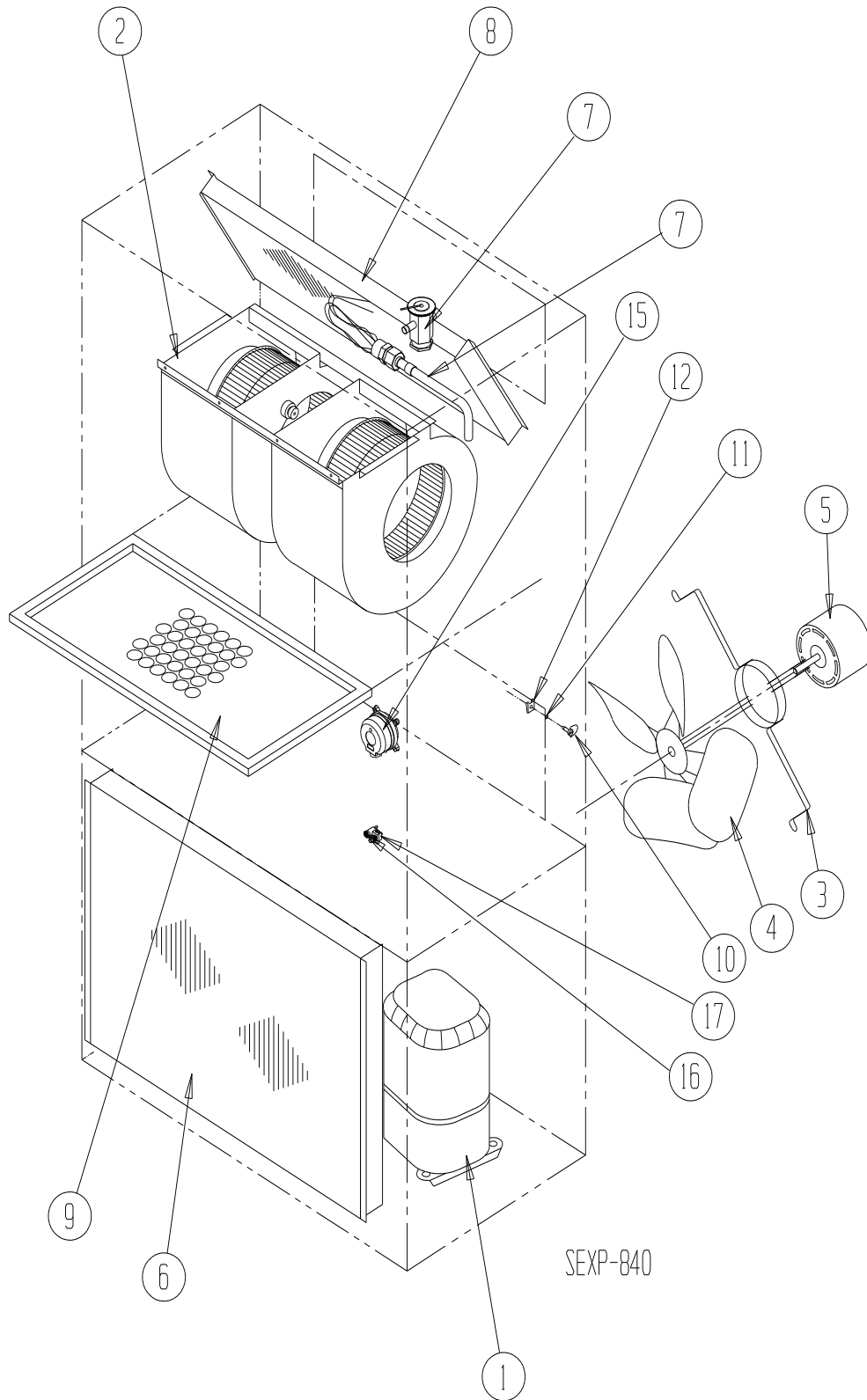

# FUNCTIONAL COMPONENTS

## H24AA-A, H24LA-A

Dwg No.	Part Number	Description
1	8000-314	Compressor
2	S900-326	Blower Assembly – See page 12
3	8200-001	Fan Motor Mount
3	8200-050 ①	Stainless Steel Fan Motor Mount
4	5151-033	Fan Blade
4	5151C033 ①	Coated Fan Blade
5	8103-016	Condenser Motor
6	5051-204BX	Condenser Coil
7	800-0459	Distributor Assembly
8	917-0277BX	Evaporator Coil with Distributor Assembly
9	7004-025	Air Filter 2" Pleated
10	1171-022	1/4" Turn Fastener
11	1171-024	1/4" Turn Retainer
12	1171-023	1/4" Receptacle
15	8301-057	Filter Switch with Adjustments
16	8611-094	Indicator Light
17	910-1973	Switch Wire Harness
NS	8406-142	High Pressure Switch (Flare)
NS	8406-140	Low Pressure Switch (Flare)
NS	CMA-28	Low Ambient Control (Flare)
NS	5201-021	Filter Drier
NS	5204-001	Subcooling Heat Exchanger
NS	6031-009	Coremax Valve Core

① – Used with stainless steel cabinet option      NS – Not Shown

## H36AA-A, H36LA-A

Dwg No.	Part Number	Description
1	8000-309	Compressor
2	S900-231	Blower Assembly – See page 12
3	8200-001	Fan Motor Mount
3	8200-050 ①	Stainless Steel Fan Motor Mount
4	5151-045	Fan Blade
4	5151C045 ①	Coated Fan Blade
5	8103-013	Condenser Motor
6	5051-202BX	Condenser Coil
7	800-0456	Distributor Assembly
8	917-0274BX	Evaporator Coil w/Distributor Assy.
9	7004-026	Air Filter 2" Pleated
10	1171-022	1/4" Turn Fastener
11	1171-024	1/4" Turn Retainer
12	1171-023	1/4" Receptacle
15	8301-057	Filter Switch with Adjustments
16	8611-094	Indicator Light
17	910-1973	Switch Wire Harness
NS	8406-142	High Pressure Switch (Flare)
NS	8406-140	Low Pressure Switch (Flare)
NS	CMA-28	Low Ambient Control (Flare)
NS	5201-021	Filter Drier
NS	6031-009	Coremax Valve Core

① – Used with stainless steel cabinet option      NS – Not Shown

# BLOWER ASSEMBLY

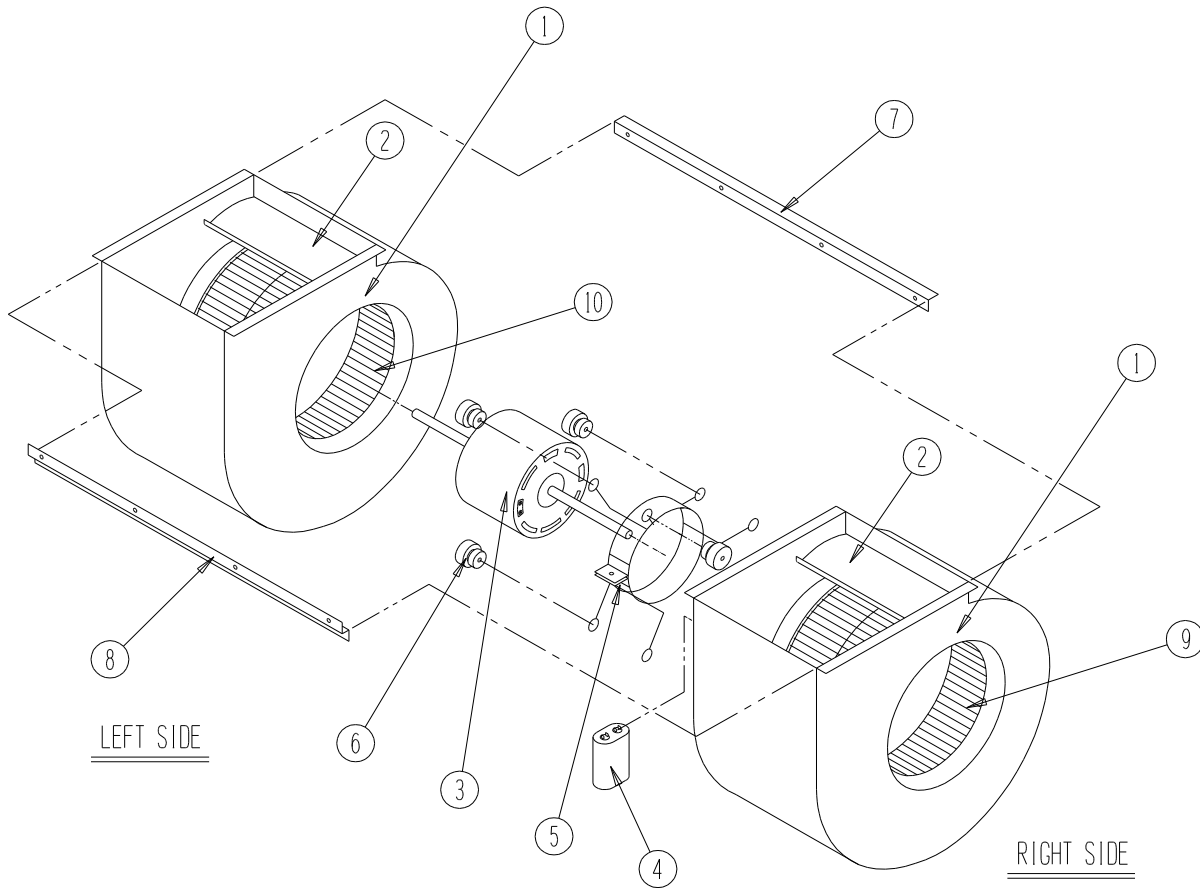

SEXP-346

**S900-326**  
**H24AA-A, H24A4-A**

Dwg No.	Part Number	Description
1	151-115	Housing
2	144-183	Cutoff
3	8102-016	Blower Motor (230/208)
4	8552-004	Capacitor
5	8200-031	Motor Mount
6	5451-011	Grommets
7	105-1061	Back Brace
8	103-435	Front Brace
9	5152-092	Wheel 9-6 CW
10	5152-093	Wheel 9-6 CCW

**S900-231**  
**H36AA-A, H36LA-A**

Dwg No.	Part Number	Description
1	151-111	Housing
2	144-174	Diffuser
3	8105-029	Blower Motor (230/208)
4	8552-002	Capacitor
5	8200-031	Motor Mount
6	5451-011	Grommets
7	105-870	Back Brace
8	103-401	Front Brace
9	5152-090	Wheel CW
10	5152-091	Wheel CCW

*This page intentionally left blank*

# CONTROL PANEL - H24AA-A, H36AA-A

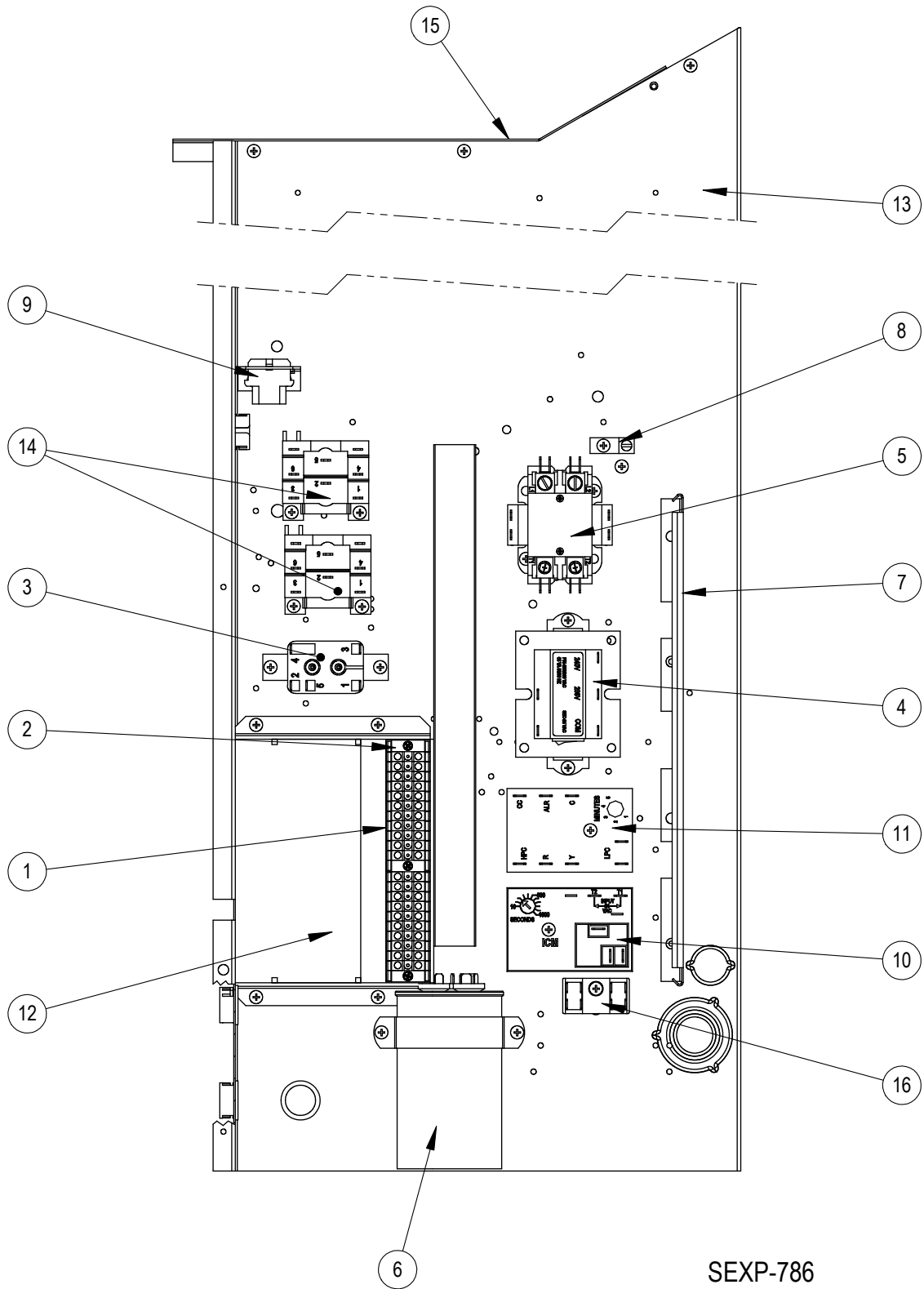

SEXP-786

This drawing to be used for reference for page 16

**CONTROL PANEL - H24LA-A, H36LA-A**

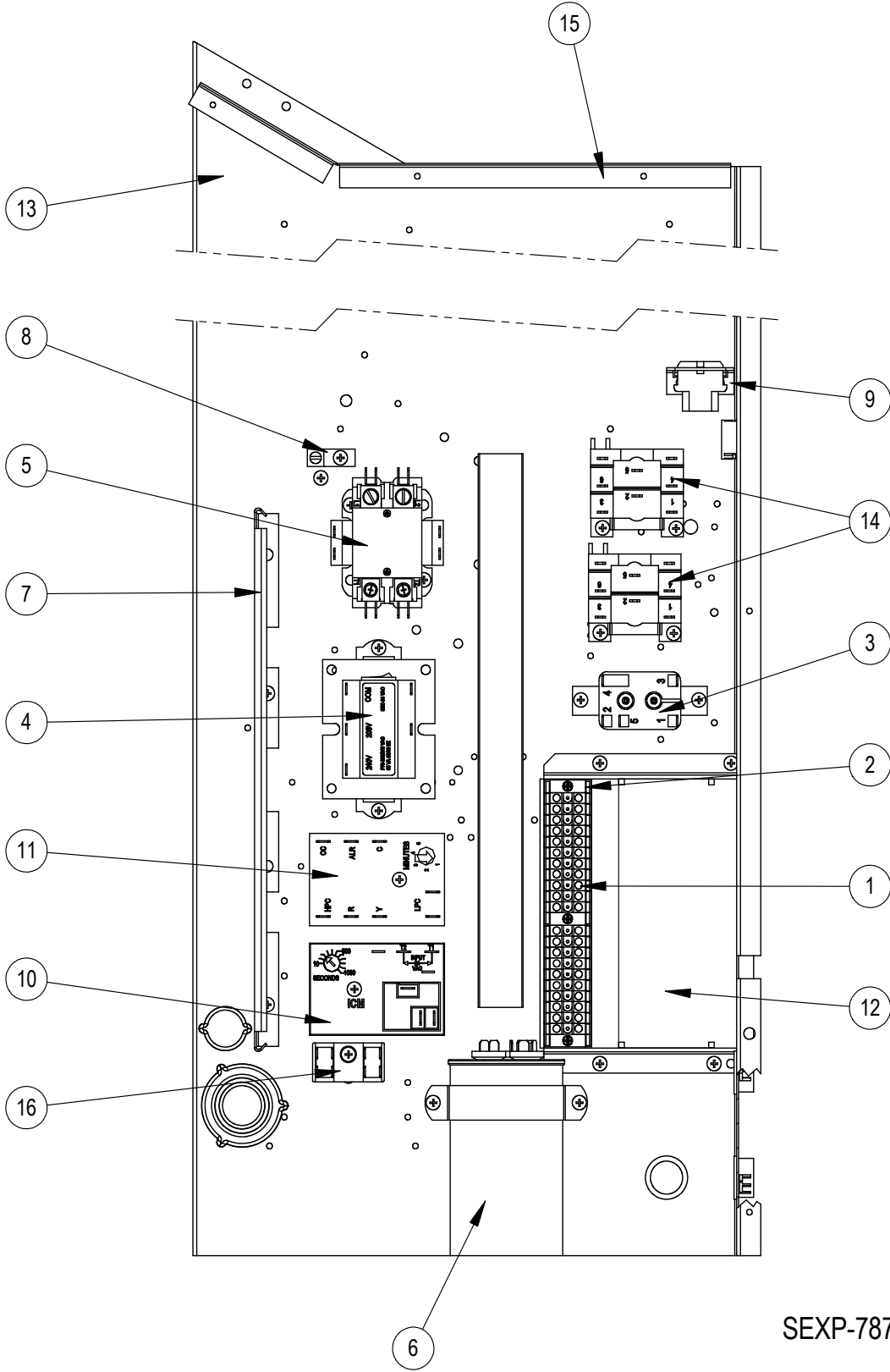

SEXP-787

This drawing to be used for reference for page 16

## CONTROL PANEL – H24AA-A, H24LA-A, H36AA-A, H36LA-A

Dwg No.	Part Number	Description
1	8607-046	Terminal Block Section
2	8607-047	Terminal Strip Mount Section
3	8201-062	Dirty Filter Relay
4	8407-065	Transformer
5	8401-034	Compressor Contactor
6	8552-052	Compressor Capacitor (H36AA-A, H36LA-A)
6	8552-051	Compressor Capacitor (H24AA-A, H24LA-A)
7	135-122	Wire Shield
8	8611-006	Ground Terminal
9	3000-1529	6 Pin Connector
10	8201-133	Time Delay Relay
11	8201-148	Compressor Control Module
12	117X386	Low Voltage Box (H24AA-A, H36AA-A)
12	117Y386	Low Voltage Box (H24LA-A, H36LA-A)
13	117X123	Control Panel (H24AA-A, H36AA-A)
13	117Y123	Control Panel (H24LA-A, H36LA-A)
14	8201-086	Indoor Blower Relay
15	117X137	Control Panel Top (H24AA-A, H36AA-A)
15	117Y137	Control Panel Top (H24LA-A, H36LA-A)
16	8607-017	Terminal Block
NS	8615-036	Circuit Breaker 25A 2 Pole ①
NS	8615-038	Circuit Breaker 35A 2 Pole ①
NS	3000-1516	Vent Wire Assembly – 12 Terminal
NS	3000-1276	Compressor Plug Wire Assembly
NS	4095-187	Wiring Diagram

NS – Not Shown

① Circuit breakers listed are for units without electric heat, “OZ” models. Hot gas bypass models not available without electric heat. See Heater Replacement Parts Manual for units with electric heat.

Refer to drawings on pages 14 and 15