

---

# REPLACEMENT PARTS MANUAL

---

## FUSION-TEC™ WALL-MOUNT AIR CONDITIONER

Models:

HR36APA HR36APB

HR58APA HR58APB

*Part of the Bard Free Cooling Unit System*

---

### Contents

Description	Page	Description	Page
Cabinet Components		Freecooling Damper Motor	
♦ Exploded View .....	2	♦ Exploded View .....	12
♦ Usage List .....	3	♦ Usage List .....	12
Functional Components		Anti-Theft Kit (Optional)	
♦ Layout View .....	4	♦ Layout View .....	13
♦ Usage List .....	5	♦ Usage List .....	13
Control Panel – 1 Phase			
♦ Layout View .....	6		
♦ Usage List .....	7		
Control Panel – 3 Phase			
♦ Layout View .....	8		
♦ Usage List .....	9		
Blower Assembly Components			
♦ Exploded View .....	10		
♦ Usage List .....	10		
Heater Packages			
♦ Exploded View .....	11		
♦ Usage List .....	11		

### General Notes

- Revised and/or additional pages may be issued from time to time.
- A complete and current manual consists of pages shown in the following contents section.

### Important

- Contact the installing and/or local Bard distributor for all parts requirements. Make sure to have the complete model and serial number available from the unit rating plates.



Bard Manufacturing Company, Inc.  
Bryan, Ohio 43506  
www.bardhvac.com

Manual: 2110-1540G  
Supersedes: 2110-1540F  
Date: 5-16-18  
**REVISED: 1-25-21**

# CABINET COMPONENTS

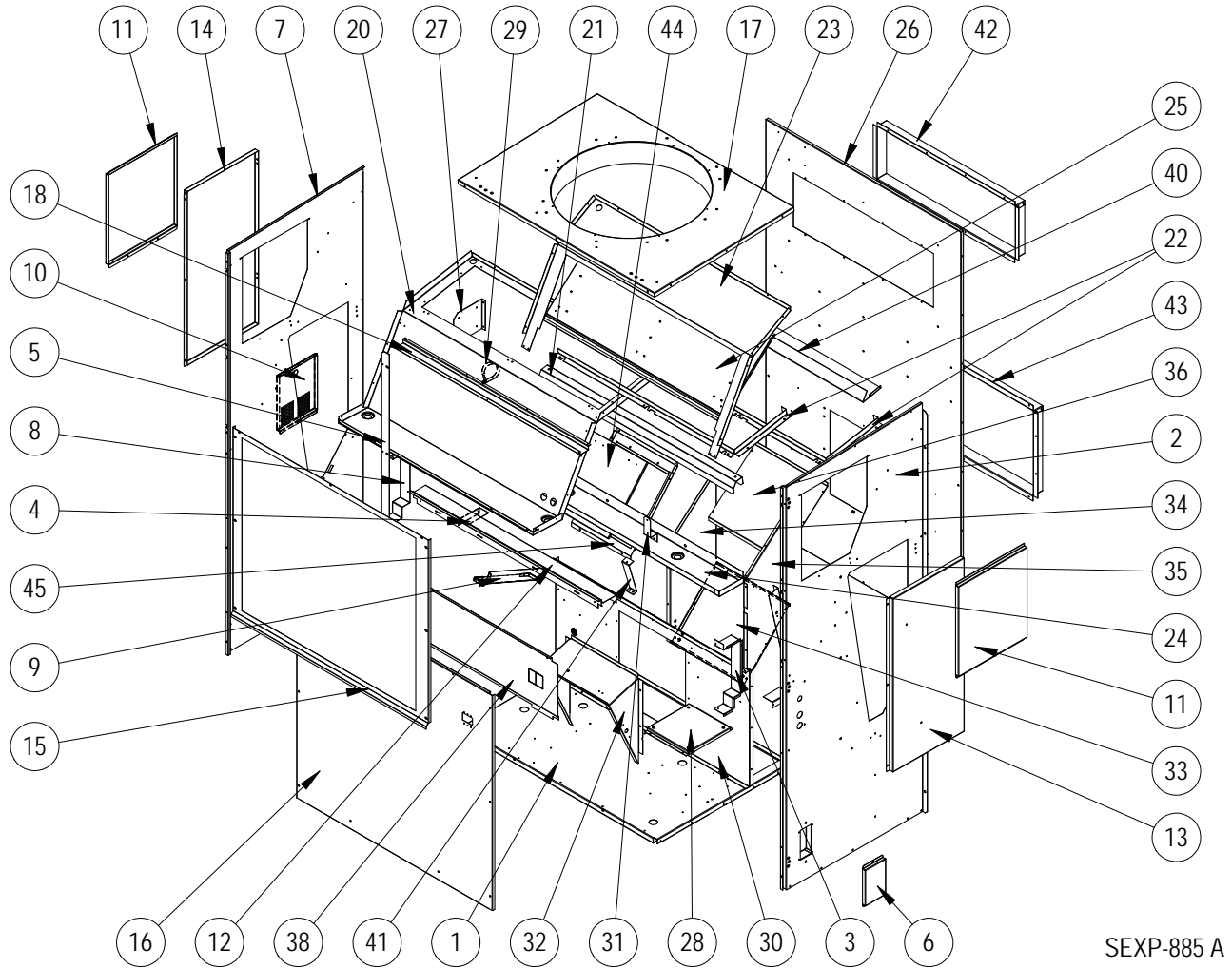

**NOTE:** When replacing parts in the upper condenser area, note any use of caulk as a sealant. Be sure to replace caulk seals using 100% silicone outdoor-rated caulk.

# CABINET COMPONENTS

Dwg No.	Part Number	Description	HR36AP*	HR58AP*
1	527-538	Unit Base	X	X
2	S501-1001-* ①	Right Side – Standard Unit	X	X
2	S501-1028-* ②	Right Side – Bard Guard Unit	X	X
3	105X1413	Right Control Panel Angle	X	X
4	105-1416	Drain Pan Angle	2	2
5	105-1425	Condenser Coil Angle	X	X
6	S543-212-* ①	Coremax Box Cover	X	X
7	S501-1002-* ①	Left Side Assembly – Standard Unit	X	X
7	S501-1029-* ②	Left Side Assembly – Bard Guard Unit	X	X
8	105Y1413	Left Control Panel Angle	X	X
9	113-681	Wire Bracket	X	X
10	S533-704-* ①	Control Panel Door	X	X
11	S143-210-* ①	Condenser Access Panel	2	2
12	S135-383-* ①	Rain Channel/Coil Riser	X	X
13	S543-211-* ①	Right Filter Panel	X	X
14	S543-213-* ①	Left Filter Panel	X	X
15	118-117-* ①	Condenser Grille	X	X
16	S533-288-* ①	Control Panel Cover	X	X
17	S107-377-* ①	Unit Top	X	X
18	137-880	Upper Condenser Fill	X	X
20	521-558-* ①	Lower Condenser Partition w/ Damper Frame	X	X
21	131-166	Upper Filter Angle	X	X
22	111-273	Outdoor Air Frame	X	X
23	521-554-* ①	Upper Condenser Partition	X	X
24	S123-154	Drain Pan	X	X
25	921-0035	Exhaust Damper Blade Assembly	X	X
26	S509-392	Back Assembly	X	X
27	113-677	Motor Control Bracket	X	X
28	127-555	Compressor Isolation Plate	X	X
29	8550-011	2-1/2" Single Hole Strap	X	X
30	521-555	Evaporator Partition	X	X
31	113-678	Filter Switch Hose Bracket	X	X
32	111-269	Blower Mounting Duct Flange	X	X
33	539-363	Supply Duct Bottom	X	X
34	539-364	Supply Duct Left	X	X
35	539-365	Supply Duct Right	X	X
36	539-366	Supply Duct Top	X	X
38	S133-290	Inner Control Panel Cover	X	X
40	143-214	Evaporator Coil Cover	X	X
41	113-682	EEV Bracket	X	X
42	111-115	Return Air Frame	X	X
43	111-270	Supply Air Frame	X	X
44	S139-367	Outdoor Damper Blade	2	2
45	S105-1414	Outdoor Damper Frame	2	2
NS	113-150-* ①	Rain Flashing	X	X
NS	113-704	Motor Cradle Mount	X	X
NS	S518-119	Lower Intake Grille Assembly	X	X

① Standard unit exterior cabinet parts are manufactured with various paint color options. To ensure the proper paint color is received, please reference the following codes: Beige -X, White -1, Buckeye Gray -4, Desert Brown -5, Dark Bronze -8

② Bard Guard unit sides are manufactured with various paint color options. To ensure the proper paint color is received, please reference the following codes: Beige -X, White -1, Buckeye Gray -4, Desert Brown -5, Dark Bronze -8

# FUNCTIONAL COMPONENTS

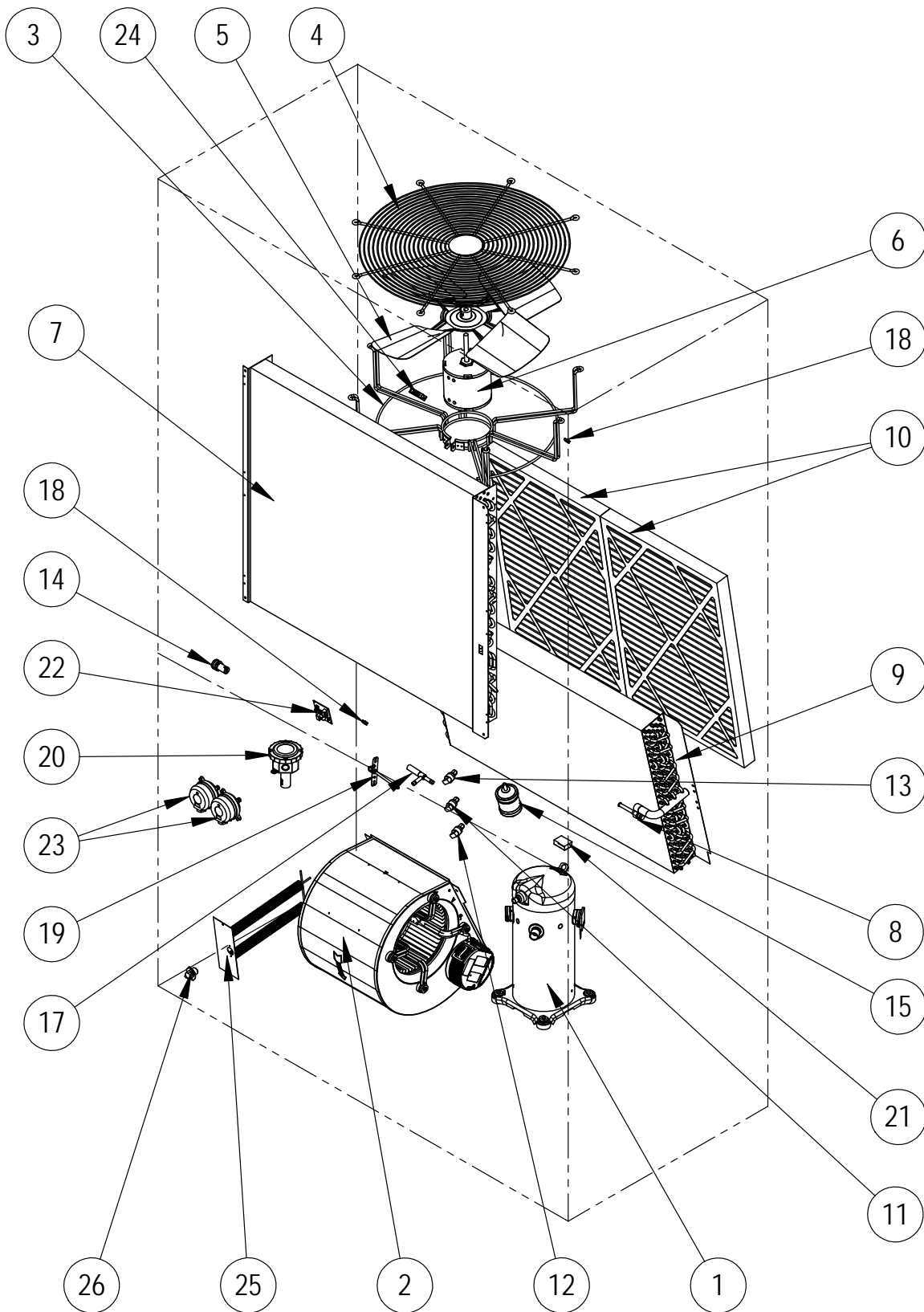

SEXP-886

## FUNCTIONAL COMPONENTS

Dwg No.	Part Number	Description	HR36APA	HR36APB	HR58APA	HR58APB
1	8000-379	Compressor	X			
1	8000-380	Compressor		X		
1	8000-385	Compressor			X	
1	8000-386	Compressor				X
2	S5154-002-0146	Blower Assembly	X	X		
2	S5154-007-0142	Blower Assembly			X	X
3	8200-055	Condenser Motor Mount	X	X	X	X
4	7051-091	Condenser Discharge Grille	2	2	2	2
5	5151-062	Fan Blade	X	X	X	X
6	S8105-070-0145	Condenser Fan Motor	X	X		
6	S8106-061-0132	Condenser Fan Motor			X	X
7	5051-217	Condenser Coil	X	X		
7	5054-217	Condenser Coil – Coated	X	X		
7	5051-216	Condenser Coil			X	X
7	5054-216	Condenser Coil – Coated			X	X
8	800-0460	Distributor Assembly	X	X		
8	800-0417	Distributor Assembly			X	X
9	917-0343	Evaporator Coil	X	X		
9	917-0344	Evaporator Coil – Coated	X	X		
9	917-0339	Evaporator Coil			X	X
9	917-0340	Evaporator Coil – Coated			X	X
10	7004-027	Air Filter MERV 8 (20"x30"x2")	2	2	2	2
11	8406-157	Liquid Line Pressure Transducer	X	X	X	X
12	8406-158	Suction Pressure Transducer	X	X	X	X
13	8406-142	High Pressure Switch	X	X	X	X
14	8611-199	Filter Service LED	X	X	X	X
15	5201-022	Filter Drier	X	X	X	X
17	5651S244	Electronic Expansion Valve (less cable and stator – see NS below)	X	X		
17	5651S245	Electronic Expansion Valve (less cable and stator – see NS below)			X	X
18	8408-044	Evaporator Temp Sensor	2	2	2	2
18	8408-044	Return Air Sensor				
19	8301-066	Supply Air Temp Sensor	X	X	X	X
20	8301-067	Outdoor Temp and Humidity Sensor	X	X	X	X
21	8301-073	Dust (Particulate) Sensor	X	X	X	X
22	8612-061	Dust (Particulate) Sensor Board	X	X	X	X
23	8301-057	Filter Switch w/Adjustment	2	2	2	2
23	8301-057	Blower Fail Switch w/Adjustment				
24	8406-150	Damper Blade Switch	X	X	X	X
25	--	Reference page 11	X	X	X	X
26	--	Reference page 11	X	X	X	X
NS	6301-009	Coremax Valve Core	2	2	2	2
NS	8605-019	Compressor Crankcase Heater ①	X	X		
NS	8605-017	Compressor Crankcase Heater ①			X	X
NS	8602-040	Damper Hinge	7	7	7	7
NS	8602-084	37-1/4" Rod	2	2	2	2
NS	5651-246	Electronic Expansion Valve Cable and Stator	X	X	X	X
NS	8615-092	Circuit Breaker Boot	X	X	X	X
NS	8408-053	Freeze Stat	X	X	X	X

① – Optional on these models

NS – Not Shown

# CONTROL PANEL - 1 PHASE

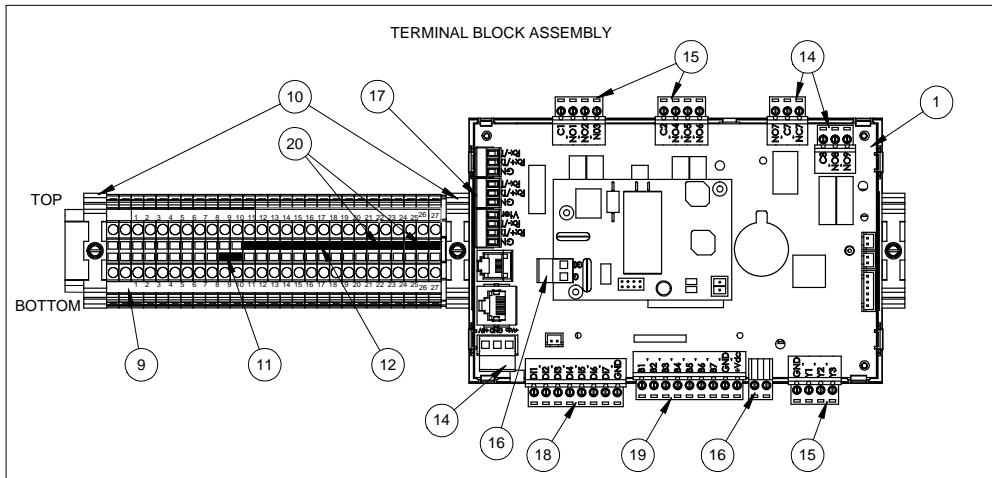
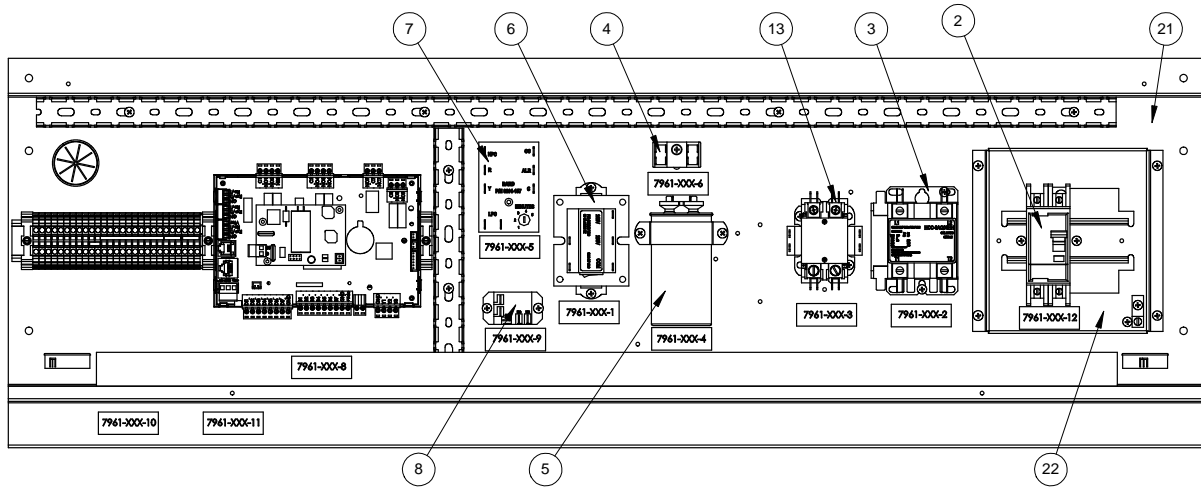

SEXP-887 A

## CONTROL PANEL – 1 PHASE

Dwg No.	Part Number	Description	HR36APA	HR58APA
1	8301-068-002*	UPC3-FUSION-TEC 1.0.0	X	X
2	8615-038	Circuit Breaker 35A 2-Pole	X	
2	8615-041	Circuit Breaker 60A 2-Pole		X
3	8401-038	Contactora 2-Pole 40 Amp (Compressor)	X	X
4	8607-017	Terminal Block 240V 2 Terminal	X	X
5	8552-035 ①	Capacitor 40MFD 370V 1.5" R	X	
5	8552-096	Capacitor 40MFD 440V 2" R		X
6	8407-065	Transformer 208/240-24 75VA	X	X
7	8201-164	Compressor Control Module	X	X
8	8201-130	Relay Pilot Duty	X	X
9	8611-150	DIN Rail Terminal Block	X	X
10	8611-144	DIN Rail End Clamp	X	X
11	8611-194	2 Position Jumper	X	X
12	8611-203	10 Position Jumper	X	X
13	8401-034	Contactora 2-Pole 40 Amp (Heat)	X	X
14	8611-147	3-Pin Circuit Board Connector	3	3
15	8611-148	4-Pin Circuit Board Connector	3	3
16	8611-183	2-Pin Circuit Board Connector	2	2
17	8611-192	3-Pin Circuit Board Connector	1	1
18	8611-185	8-Pin Circuit Board Connector	1	1
19	8611-149	9-Pin Circuit Board Connector	1	1
20	8611-208	3 Position Jumper	2	2
21	517-400	Control Panel	X	X
22	127-556	Circuit Breaker Base	X	X

\* Replacement part will have a letter attached to the end of the part number to designate software version (Example: 8301-068-002**A**). A software upgrade of all PLCs onsite (units and controllers) should accompany any PLC replacement. Latest revisions of software, change log and instructions are available on the Bard website at <http://www.bardhvac.com/software-download/>

① Capacitor mounted to HR36APA control panel

Wiring diagram reference listed under **HEATER PACKAGES** on page 11

# CONTROL PANEL - 3 PHASE

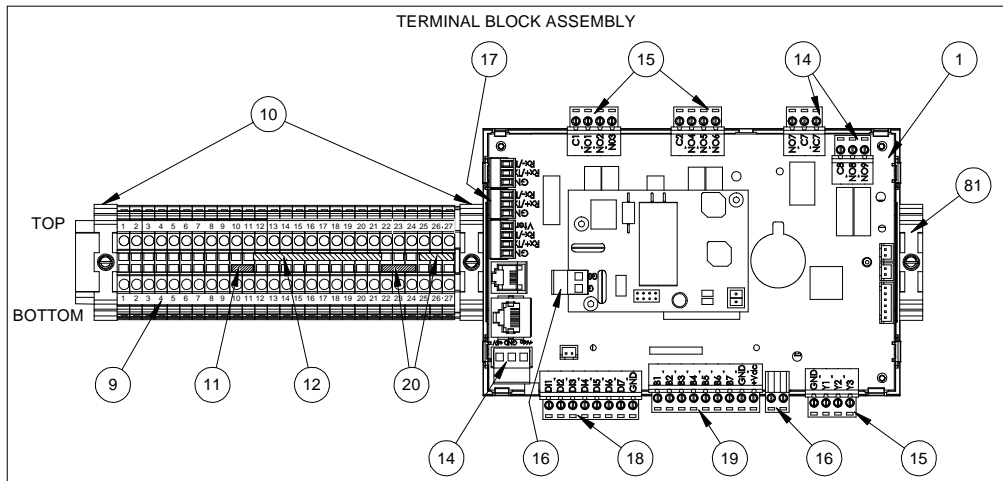
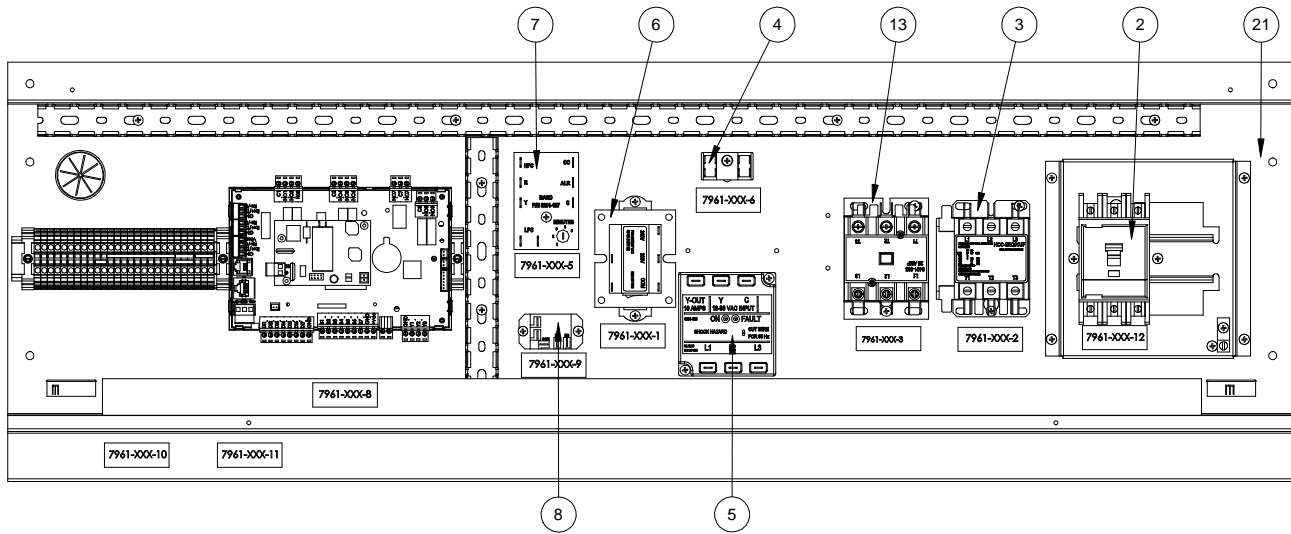

SEXP-891



## CONTROL PANEL – 3 PHASE

Dwg No.	Part Number	Description	HR36APB	HR58APB
1	8301-068-002*	UPC3-FUSION-TEC 1.0.0	X	X
2	8615-044	Circuit Breaker 45A 3-Pole	X	
2	8615-052	Circuit Breaker 30A 3-Pole		X
3	8401-037	Contactora 3-Pole 30 Amp (Compressor)	X	X
4	8607-017	Terminal Block 240V 2 Terminal	X	X
5	8201-126	3 Phase Line Monitor 50/60 HZ	X	X
6	8407-065	Transformer 208/240-24 75VA	X	X
7	8201-164	Compressor Control Module	X	X
8	8201-130	Relay Pilot Duty	X	X
9	8611-150	DIN Rail Terminal Block	X	X
10	8611-144	DIN Rail End Clamp	X	X
11	8611-194	2 Position Jumper	X	X
12	8611-203	10 Position Jumper	X	X
13	8401-035	Contactora 3-Pole 25 Amp (Heat)	X	X
14	8611-147	3-Pin Circuit Board Connector	3	3
15	8611-148	4-Pin Circuit Board Connector	3	3
16	8611-183	2-Pin Circuit Board Connector	2	2
17	8611-192	3-Pin Circuit Board Connector	1	1
18	8611-185	8-Pin Circuit Board Connector	1	1
19	8611-149	9-Pin Circuit Board Connector	1	1
20	8611-208	3 Position Jumper	2	2
21	517-400	Control Panel	X	X
22	127-556	Circuit Breaker Base	X	X

\* Replacement part will have a letter attached to the end of the part number to designate software version (Example: 8301-068-002**A**). A software upgrade of all PLCs onsite (units and controllers) should accompany any PLC replacement. Latest revisions of software, change log and instructions are available on the Bard website at <http://www.bardhvac.com/software-download/>

Wiring diagram reference listed under **HEATER PACKAGES** on page 11

# BLOWER ASSEMBLY COMPONENTS

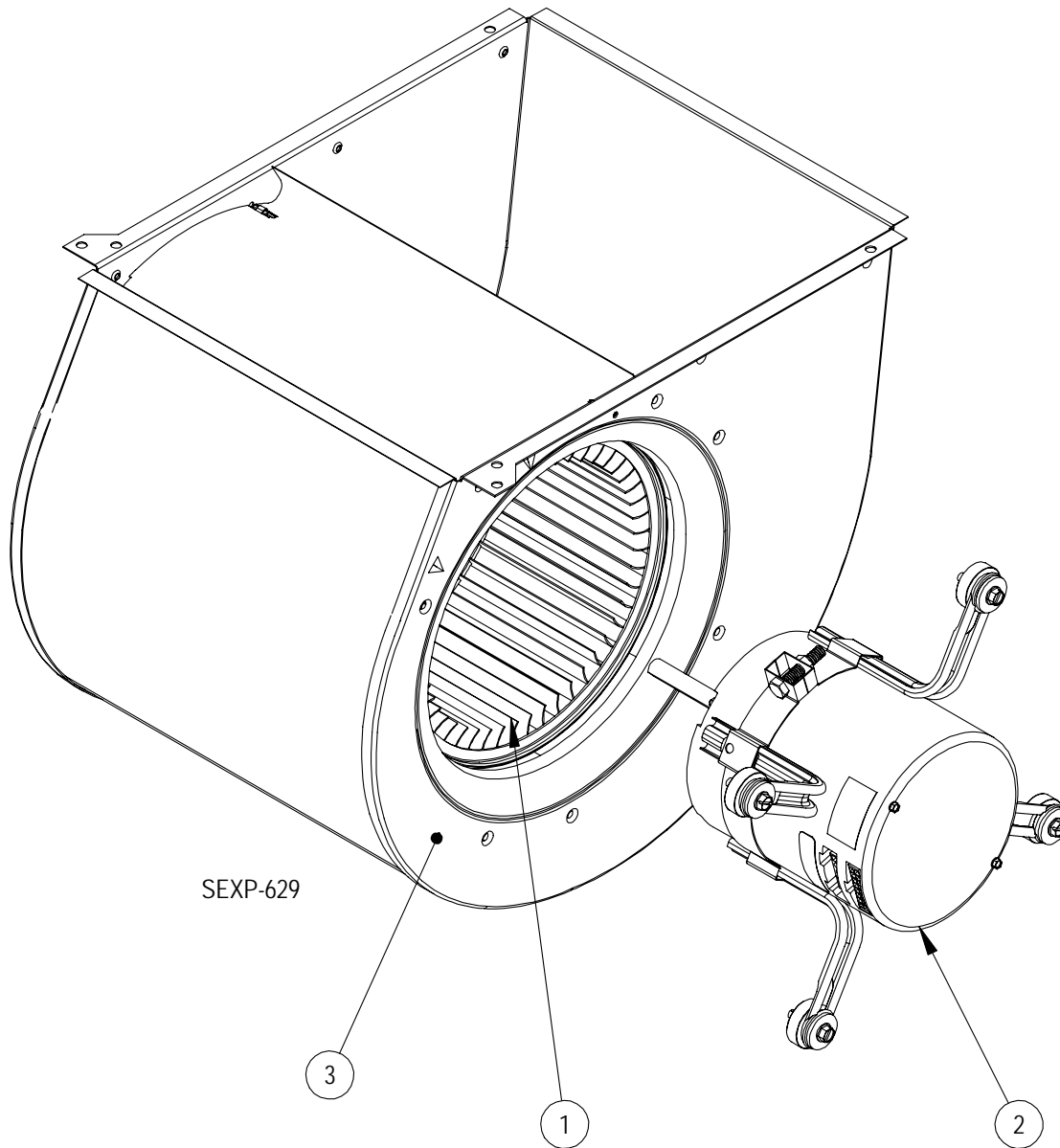

Drawing No.	Part Number	Description	5154-002-0146	5154-007-0142
1	5152-049	Blower Wheel	X	
	S8105-059-0146	1/3 HP Programmed Motor	X	
2	C8105-059-0146	1/3 HP Control Only Replacement	X	
	C5154-007-0142	3/4 HP Control Only Replacement		X
3	151-122	Housing	X	

# HEATER PACKAGES

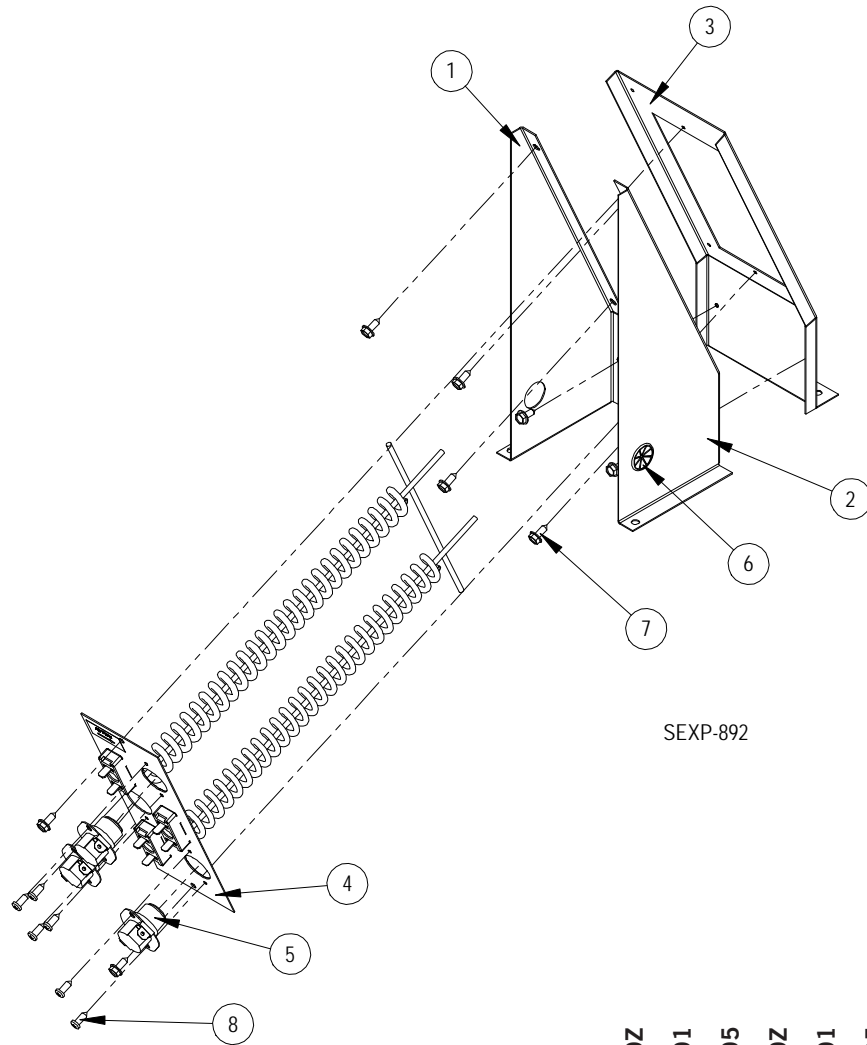

Dwg No.	Part Number	Description	HR36APA0Z	HR36APA01	HR36APA05	HR58APA0Z	HR58APA01	HR58APA05	HR36APB0Z	HR36APB05	HR58APB0Z	HR36APB05
1	113Y671	Left Heater Support		X	X		X	X		X		X
2	113X672	Right Heater Support		X	X		X	X		X		X
3	113-668	Heater Bracket Front		X	X		X	X		X		X
4	8604-150	Heat Strip 1.5KW 240V 2 Term		X			X					
4	8604-148	Heat Strip 5.0KW 240V 2 Term			X			X				
4	8604-149	Heat Strip 6.0KW 240V 3PH								X		X
5	8402-190	Limit Control 130P/150BU		1	1		1	1		3		3
6	8611-016	Universal Bushing		X	X		X	X		X		X
7	1012-065	Screw, Type AB PZPNHD #8-18X3/8		6	6		6	6		6		6
8	1012-086	Screw, Type AB HXWHD #10-16X1/2		8	8		8	8		8		8
NS	4208-100	Wiring Diagram	X			X						
NS	4208-101	Wiring Diagram		X	X		X	X				
NS	4208-200	Wiring Diagram							X		X	
NS	4208-201	Wiring Diagram								X		X

# FREECOOLING DAMPER MOTOR

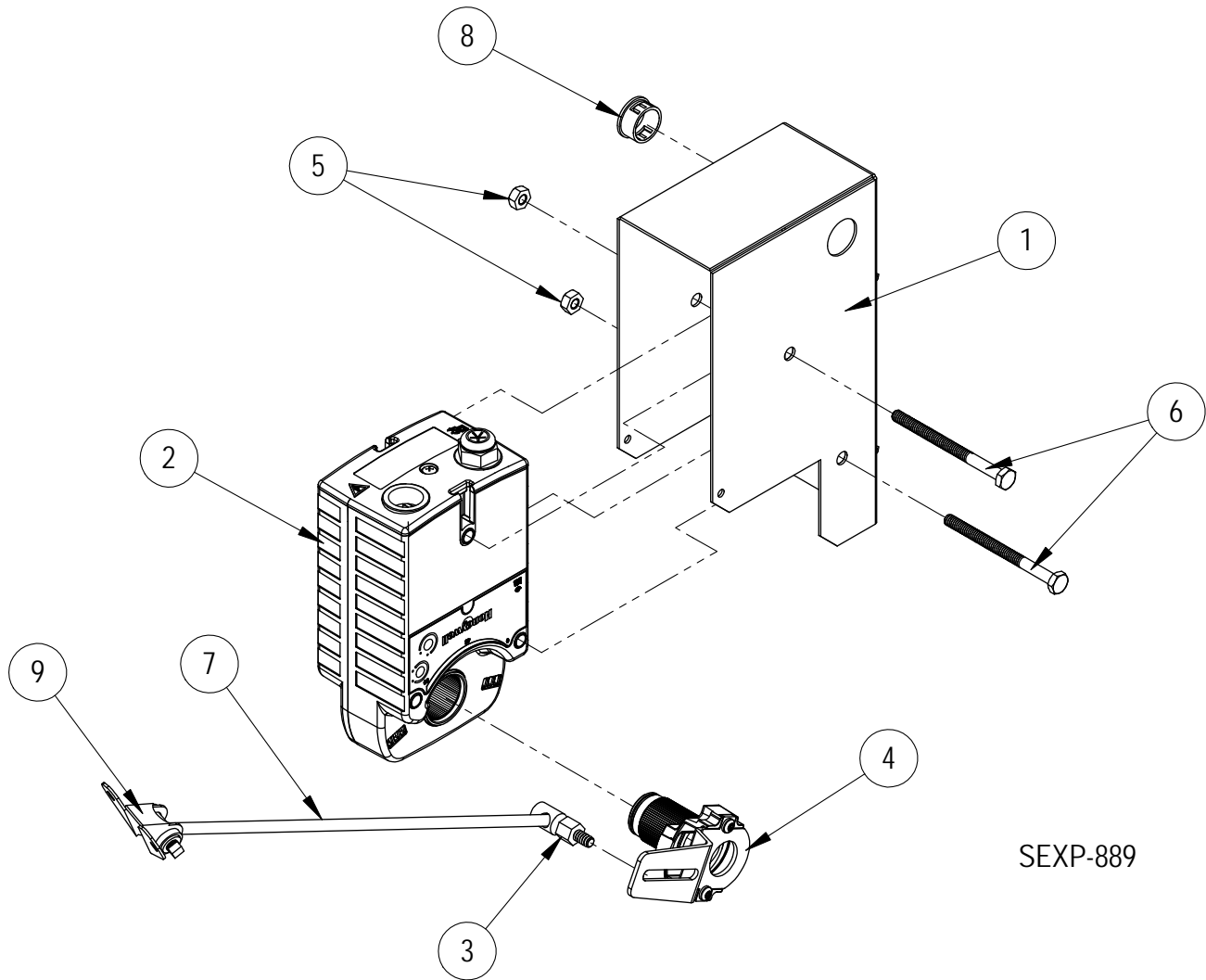

SEXP-889

Dwg. No.	Part Number	Description	All Models
1	113-694	Actuator Support Plate	X
2	8602-067	Direct Coupled Actuator	X
3	8602-008	Ball Joints	X
4	8602-068	Crank Arm	X
5	1012-201	1/4-20 Steel Keps Hex Nut Zinc	2
6	1012-174	1/4" - 20x3 - 1/4 Hex Cap Screws	2
7	8602-085	1/4" x 13-3/4" Rod	X
8	<b>8611-033</b>	<b>Snap Bushing 7/8"</b>	X
9	<b>8602-040</b>	<b>BKP-24 Bracket</b>	X

## ANTI-THEFT KIT (OPTIONAL)

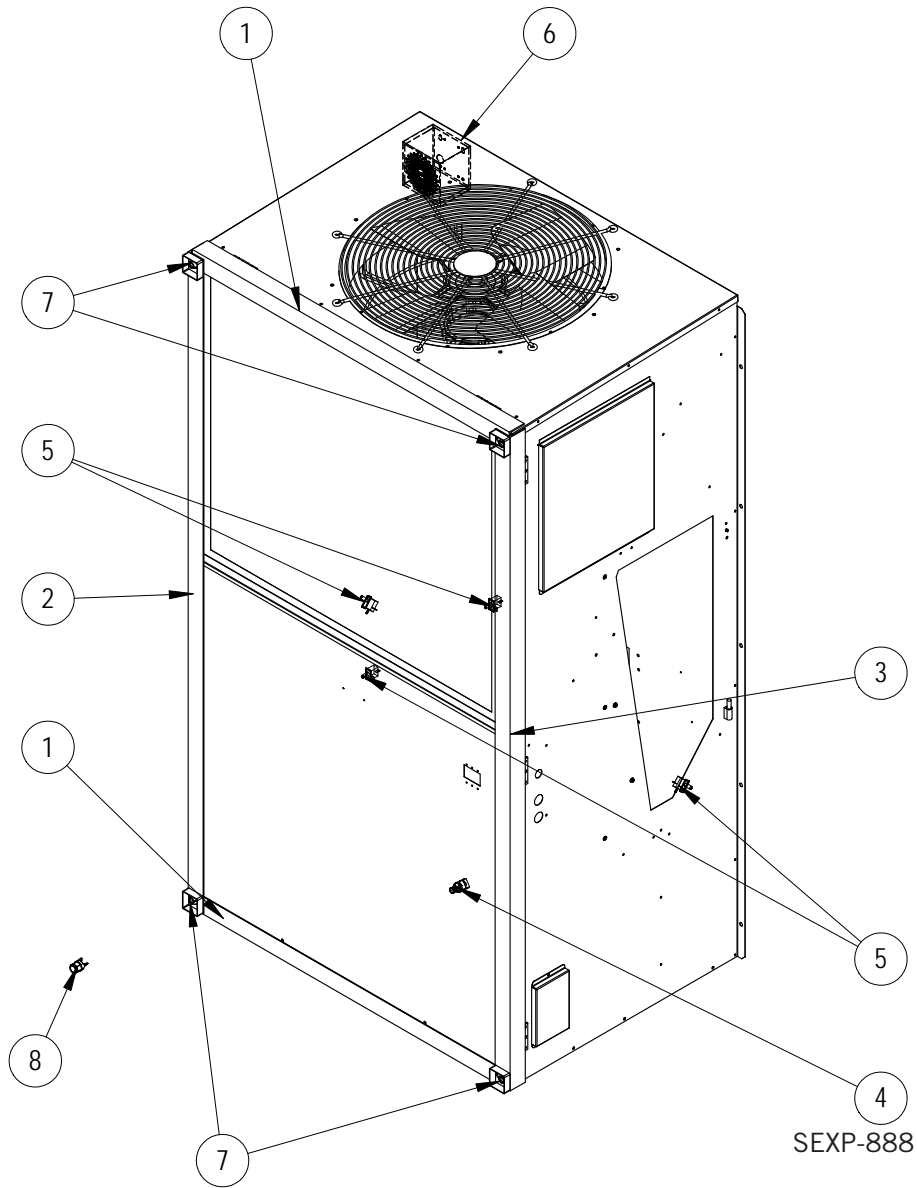

Dwg No.	Part Number	Description	HR36AP*	HR58AP*
1	9050-001	Frame Top/Bottom	2	2
2	9050-002	Left Frame Side	X	X
3	9050-003	Right Frame Side	X	X
4	8406-135	Low Pressure Switch	X	X
5	8406-156	Panel Switch	4	4
6	910-2038	Speaker Assembly	X	X
7	1012-346	Tri-Groove Nut	4	4
8	2151-022	Tri-Groove Socket – Key	X	X