REPLACEMENT PARTS MANUAL

FUSION-TEC® Wall-Mount Air Conditioner

Models: HR35BPA HR36BPA HR58BPA
HR35BPB HR36BPB HR58BPB

Contents

Description	Page	Description	Page
Cabinet Components		Heater Packages – HR35BP*	
♦ Exploded View	2	♦ Exploded View	17
♦ Usage Lists	3-4	♦ Usage List	17
Functional Components		Heater Packages – HR36BP*/HR58BP*	
♦ Layout View	6	♦ Exploded View	18
♦ Usage Lists	7-8	♦ Usage List	18
Control Panel – 1 Phase		Freecooling Damper Motor	
♦ Layout View	10	♦ Layout View	19
♦ Usage List	11	♦ Usage List	19
Control Panel – 3 Phase		Anti-Theft Kit (Optional)	
♦ Layout View	12	♦ Layout View	20
♦ Usage List	13	♦ Usage List	20
Blower Assembly Components – HR35BP*			
♦ Exploded View	14		
♦ Usage List	14		
Blower Assembly Components – HR36BP*			
♦ Exploded View	15		
♦ Usage List	15		
Blower Assembly Components – HR58BP*			
♦ Exploded View	16		
♦ Usage List	16		

General Notes

- Revised and/or additional pages may be issued from time to time.
- A complete and current manual consists of pages shown in the following contents section.

Important

- Contact the installing and/or local Bard distributor for all parts requirements. Make sure to have the complete model and serial number available from the unit rating plates.



Bard Manufacturing Company, Inc.
Bryan, Ohio 43506
www.bardhvac.com

Manual: 2110-1546F
Supersedes: 2110-1546E
Date: 11-10-20

CABINET COMPONENTS

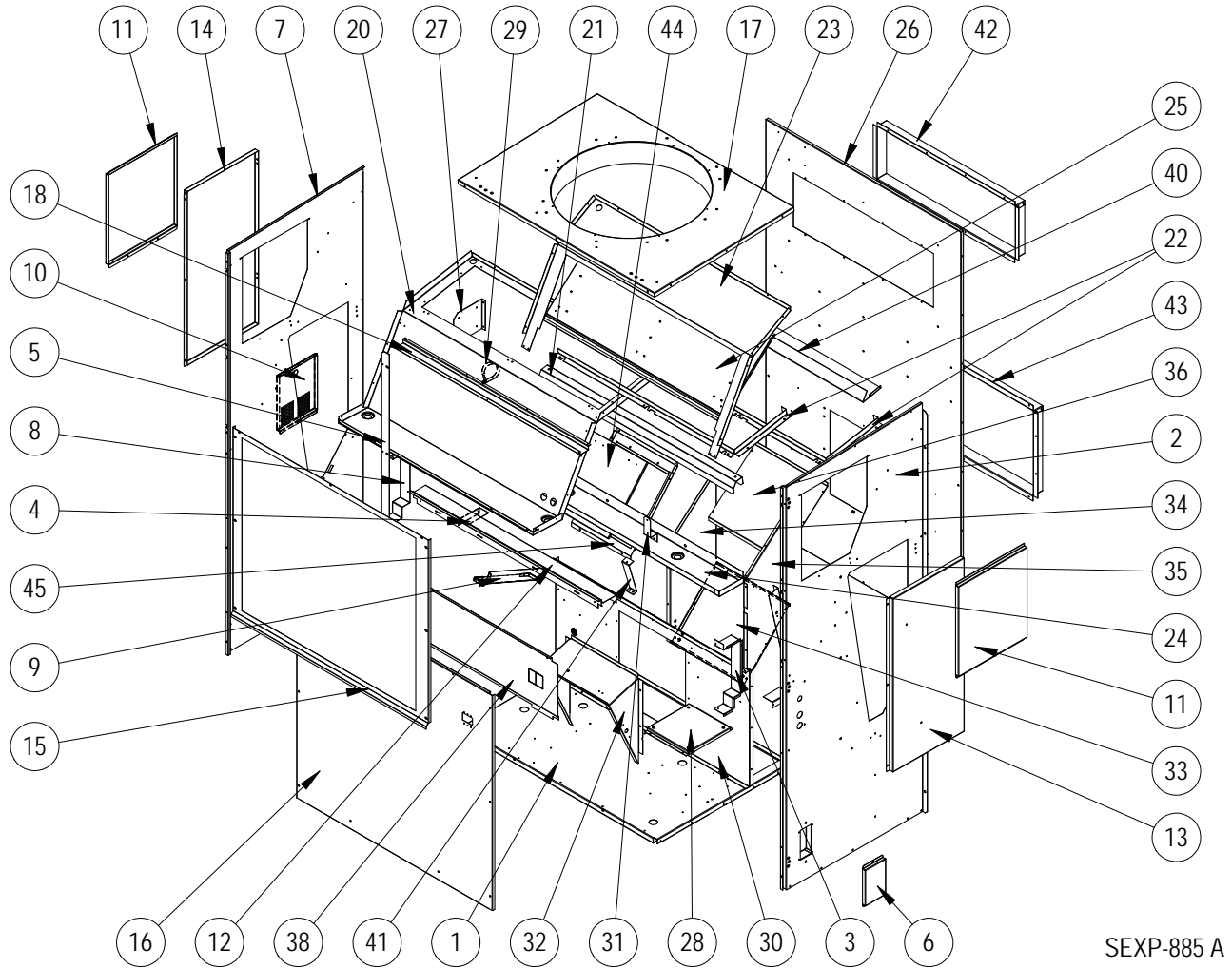

NOTE: When replacing parts in the upper condenser area, note any use of caulk as a sealant. Be sure to replace caulk seals using 100% silicone outdoor-rated caulk.

This drawing is referenced in tables on pages 3 and 4

CABINET COMPONENTS

Dwg No.	Part Number	Description	HR35BPA	HR35BBB
1	527-545	Unit Base	X	X
2	S501-1015-* ①	Right Side	X	X
3	105X1434	Right Control Panel Angle	X	X
4	105-1416	Drain Pan Angle	X	X
5	105-1447	Condenser Coil Fill	X	X
6	S543-212-* ①	Coremax Box Cover	X	X
7	501-1016-* ①	Left Side Assembly	X	X
8	105Y1434	Left Control Panel Angle	X	X
9	113-696	Wire Bracket	X	X
10	S533-704-* ①	Sensor Access Door	X	X
11	S143-217-* ①	Condenser Access Panel	2	2
12	S135-893-* ①	Coil Riser	X	X
13	S543-215-* ①	Right Filter Panel	X	X
14	S543-218-* ①	Left Filter Panel	X	X
15	118-120-* ①	Condenser Grille	X	X
16	S533-293-* ①	Control Panel Cover	X	X
17	S107-384-* ①	Unit Top	X	X
18	137-892	Upper Condenser Fill	X	X
20	521-560-* ①	Lower Condenser Partition w/ Damper Frame	X	X
21	131-167	Upper Filter Angle	X	X
22	111-295	Outdoor Air Frame	X	X
23	521-564-* ①	Upper Condenser Partition	X	X
24	S123-155	Drain Pan	X	X
25	921-0055	Exhaust Damper Blade Assembly	X	X
26	S509-397	Back Assembly	X	X
27	113-677	Motor Control Bracket	X	X
28	127-555	Compressor Isolation Plate	X	X
29	8550-011	2-1/2" Single Hole Strap	X	X
30	521-565	Evaporator Partition	X	X
31	113-678	Filter Switch Hose Bracket	X	X
32	105-1435	Left Blower Mounting Angle	X	X
32	105-1443	Right Blower Mounting Angle	X	X
33	539-372	Supply Duct Bottom	X	X
34	539-373	Supply Duct Left	X	X
35	539-374	Supply Duct Right	X	X
36	539-375	Supply Duct Top	X	X
38	S133-294	Inner Control Panel Cover	X	
38	S133-311	Inner Control Panel Cover		X
40	143-216	Evaporator Coil Cover	X	X
42	111-296	Return Air Frame	X	X
43	111-297	Supply Air Frame	X	X
44	S139-376	Outdoor Damper Blade	2	2
45	105-1432	Outdoor Damper Frame	2	2
NS	113-740	Rain Flashing	X	X
NS	113-704	Motor Cradle	X	X
NS	S518-121	Lower Intake Grille Assembly	X	X

① Standard unit exterior cabinet parts are manufactured with various paint color options. To ensure the proper paint color is received, please reference the following codes: Beige -X, White -1, Buckeye Gray -4, Desert Brown -5, Dark Bronze -8

NS – Not Shown

CABINET COMPONENTS

Dwg No.	Part Number	Description	HR36BPA	HR36BPB	HR58BPA	HR58BPB
1	527-573	Unit Base	X	X	X	X
2	S501-1001-* ①	Right Side – Standard Unit	X	X	X	X
3	105X1413	Right Control Panel Angle	X	X	X	X
4	105-1416	Drain Pan Angle	2	2	2	2
5	105-1425	Condenser Coil Angle	X	X	X	X
6	S543-212-* ①	Coremax Box Cover	X	X	X	X
7	S501-1002-* ①	Left Side Assembly – Standard Unit	X	X	X	X
8	105Y1413	Left Control Panel Angle	X	X	X	X
9	113-681	Wire Bracket	X	X	X	X
10	S533-704-* ①	Control Panel Door	X	X	X	X
11	S143-210-* ①	Condenser Access Panel	2	2	2	2
12	S135-383-* ①	Rain Channel/Coil Riser	X	X	X	X
13	S543-211-* ①	Right Filter Panel	X	X	X	X
14	S543-213-* ①	Left Filter Panel	X	X	X	X
15	118-117-* ①	Condenser Grille	X	X	X	X
16	S533-288-* ①	Control Panel Cover	X	X	X	X
17	S107-381-* ①	Unit Top	X	X	X	X
18	137-880	Upper Condenser Fill	X	X	X	X
20	521-558-* ①	Lower Condenser Partition w/ Damper Frame	X	X	X	X
21	131-166	Upper Filter Angle	X	X	X	X
22	111-273	Outdoor Air Frame	X	X	X	X
23	521-554-* ①	Upper Condenser Partition	X	X	X	X
24	S123-154	Drain Pan	X	X	X	X
25	921-0035	Exhaust Damper Blade Assembly	X	X	X	X
26	S509-392	Back Assembly	X	X	X	X
27	113-677	Motor Control Bracket	X	X	X	X
28	127-555	Compressor Isolation Plate	X	X	X	X
29	8550-011	2-1/2" Single Hole Strap	X	X	X	X
30	521-555	Evaporator Partition	X	X	X	X
31	113-678	Filter Switch Hose Bracket	X	X	X	X
32	111-332	Blower Mounting Duct Flange Top	X	X	X	X
32	111X333	Blower Mounting Duct Flange Right	X	X	X	X
32	111Y333	Blower Mounting Duct Flange Left	X	X	X	X
33	539-363	Supply Duct Bottom	X	X	X	X
34	539-364	Supply Duct Left	X	X	X	X
35	539-365	Supply Duct Right	X	X	X	X
36	539-366	Supply Duct Top	X	X	X	X
38	S133-290	Inner Control Panel Cover	X		X	
38	S133-295	Inner Control Panel Cover		X		X
40	143-214	Evaporator Coil Cover	X	X	X	X
41	113-682	EEV Bracket	X	X	X	X
42	111-115	Return Air Frame	X	X	X	X
43	111-270	Supply Air Frame	X	X	X	X
44	S139-367	Outdoor Damper Blade	2	2	2	2
45	S105-1414	Outdoor Damper Frame	2	2	2	2
NS	113-150-* ①	Rain Flashing	X	X	X	X
NS	113-704	Motor Cradle Mount	X	X	X	X
NS	S518-119	Lower Intake Grille Assembly	X	X	X	X

① Standard unit exterior cabinet parts are manufactured with various paint color options. To ensure the proper paint color is received, please reference the following codes: Beige -X, White -1, Buckeye Gray -4, Desert Brown -5, Dark Bronze -8

NS – Not Shown

This page intentionally left blank

FUNCTIONAL COMPONENTS

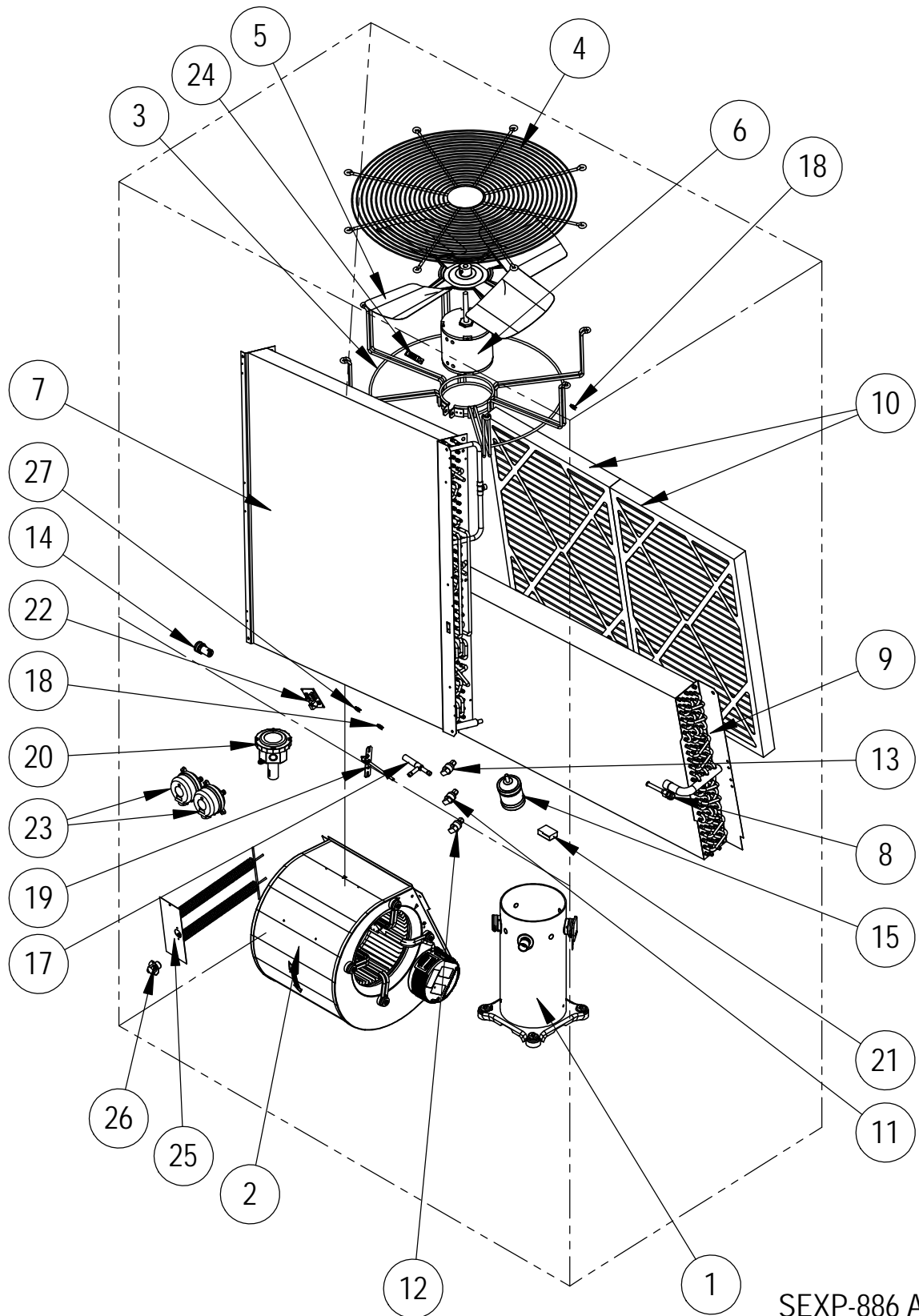

SEXP-886 A

FUNCTIONAL COMPONENTS

Dwg No.	Part Number	Description	HR35BPA	HR35BPB	HR36BPA	HR36BPB
1	8000-440	Compressor	X			
1	8000-442	Compressor		X		
1	8000-379	Compressor			X	
1	8000-380	Compressor				X
2	900-362	Blower Assembly	X	X		
2	S5154-002-0146	Blower Assembly			X	X
3	8200-054	Condenser Motor Mount	X	X		
3	8200-055	Condenser Motor Mount			X	X
4	7051-094	Condenser Discharge Grille	2	2		
4	7051-091	Condenser Discharge Grille			2	2
5	5151-064	Fan Blade	X	X		
5	5151-062	Fan Blade			X	X
6	8106-061-0167	Condenser Fan Motor	X	X		
6	S8105-070-0145	Condenser Fan Motor			X	X
7	5051-218	Condenser Coil	X	X		
7	5054-218	Condenser Coil – Coated	X	X		
7	5051-217	Condenser Coil			X	X
7	5054-217	Condenser Coil – Coated			X	X
8	800-0417	Distributor Assembly	X	X		
8	800-0460	Distributor Assembly			X	X
9	917-0349	Evaporator Coil	X	X		
9	917-0350	Evaporator Coil – Coated	X	X		
9	917-0343	Evaporator Coil			X	X
9	917-0344	Evaporator Coil – Coated			X	X
10	7004-068	Air Filter MERV 8 (18"x22"x2")	2	2	2	2
10	7004-027	Air Filter MERV 8 (20"x30"x2")	2	2	2	2
11	8406-157	Liquid Line Pressure Transducer	X	X	X	X
12	8406-158	Suction Pressure Transducer	X	X	X	X
13	8406-142	High Pressure Switch	X	X	X	X
14	8611-199	Filter Service LED	X	X	X	X
15	5201-021	Filter Drier	X	X		
15	5201-022	Filter Drier			X	X
17	5651S244	Electronic Expansion Valve (less cable and stator – see NS below)	X	X	X	X
18	8408-044	Return Air Sensor	X	X	X	X
18	8408-054	Suction Temperature Sensor	X	X	X	X
19	8301-066	Supply Air Temp Sensor	X	X	X	X
20	8301-067	Outdoor Temp and Humidity Sensor	X	X	X	X
21	8301-091	Dust (Particulate) Sensor	X	X	X	X
22	8612-064	Dust (Particulate) Sensor Board	X	X	X	X
23	8301-057	Filter Switch w/Adjustment	X	X	X	X
23	8301-057	Blower Fail Switch w/Adjustment	X	X	X	X
24	8406-150	Damper Blade Switch	X	X	X	X
25	--	Reference pages 17 and 18	X	X	X	X
26	--	Reference pages 17 and 18	X	X	X	X
27	8408-045	Liquid Line Temp Sensor	X	X	X	X
NS	6301-009	Coremax Valve Core	2	2	2	2
NS	8605-019	Compressor Crankcase Heater ①	X	X	X	X
NS	8602-040	Damper Hinge	7	7	7	7
NS	8602-095	22" Rod	2	2		
NS	8602-084	37-1/4" Rod			2	2
NS	5651-246	Electronic Expansion Valve Cable and Stator	X	X	X	X
NS	8615-092	Circuit Breaker Boot	X	X	X	X

① – Optional on these models

NS – Not Shown

FUNCTIONAL COMPONENTS

Dwg No.	Part Number	Description	HR58BPA	HR58BPB
1	8000-385	Compressor	X	
1	8000-386	Compressor		X
2	S5154-007-0142	Blower Assembly	X	X
3	8200-055	Condenser Motor Mount	X	X
4	7051-091	Condenser Discharge Grille	2	2
5	5151-062	Fan Blade	X	X
6	S8106-061-0132	Condenser Fan Motor	X	X
7	5051-216	Condenser Coil	X	X
7	5054-216	Condenser Coil – Coated	X	X
8	800-0417	Distributor Assembly	X	X
9	917-0339	Evaporator Coil	X	X
9	917-0340	Evaporator Coil – Coated	X	X
10	7004-027	Air Filter MERV 8 (20"x30"x2")	2	2
11	8406-157	Liquid Line Pressure Transducer	X	X
12	8406-158	Suction Pressure Transducer	X	X
13	8406-142	High Pressure Switch	X	X
14	8611-199	Filter Service LED	X	X
15	5201-022	Filter Drier	X	X
17	5651S245	Electronic Expansion Valve (less cable and stator – see NS below)	X	X
18	8408-044	Return Air Sensor	X	X
18	8408-054	Suction Temp Sensor	X	X
19	8301-066	Supply Air Temp Sensor	X	X
20	8301-067	Outdoor Temp and Humidity Sensor	X	X
21	8301-091	Dust (Particulate) Sensor	X	X
22	8612-064	Dust (Particulate) Sensor Board	X	X
23	8301-057	Filter Switch w/Adjustment	X	X
23	8301-057	Blower Fail Switch w/Adjustment	X	X
24	8406-150	Damper Blade Switch	X	X
25	--	Reference page 18	X	X
26	--	Reference page 18	X	X
27	8408-045	Liquid Line Temp Sensor	X	X
NS	6301-009	Coremax Valve Core	2	2
NS	8605-017	Compressor Crankcase Heater ①	X	X
NS	8602-040	Damper Hinge	7	7
NS	8602-084	37-1/4" Rod	2	2
NS	5651-246	Electronic Expansion Valve Cable and Stator	X	X
NS	8615-092	Circuit Breaker Boot	X	X

① – Optional on these models

NS – Not Shown

This table references drawing on page 6

This page intentionally left blank

CONTROL PANEL - 1 PHASE

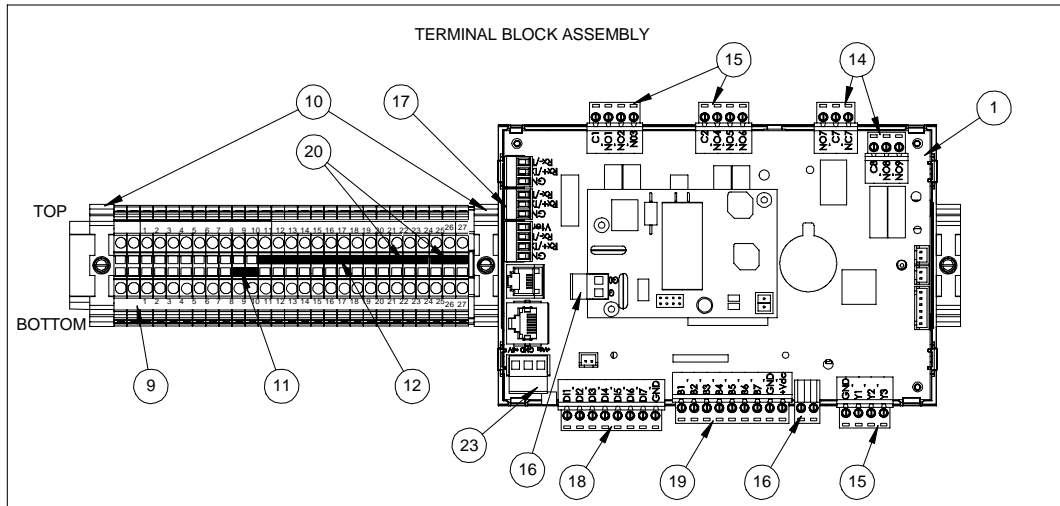
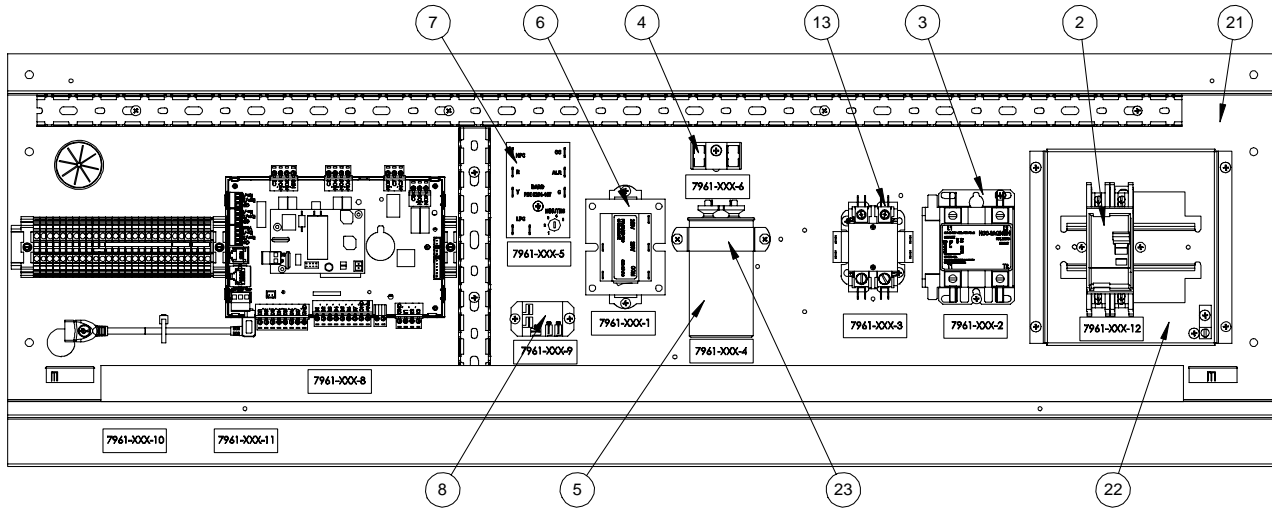

SEXP-887 B

CONTROL PANEL – 1 PHASE

Dwg No.	Part Number	Description	HR35BPA	HR36BPA	HR56BPA
1	8301-068-002*	uPC3 Core 0 FUSION-TEC HR ①	X	X	X
1	8301-096-001*	uPC3 Core 2 FUSION-TEC HR ①	X	X	X
2	8615-097	Circuit Breaker 35A 2-Pole	X	X	
2	8615-098	Circuit Breaker 60A 2-Pole			X
3	8401-038	Contactora 2-Pole 40 Amp (Compressor)	X	X	X
4	8607-017	Terminal Block 240V 2 Terminal	X	X	X
5	8552-043 ②	Capacitor 45MFD 370V 2.5" R	X		
5	8552-035 ②	Capacitor 40MFD 370V 1.5" R		X	
5	8552-096	Capacitor 40MFD 440V 2" R			X
6	8407-065	Transformer 208/240-24 75VA	X	X	X
7	8201-164	Compressor Control Module	X	X	X
8	8201-130	Relay Pilot Duty	X	X	X
9	8611-150	DIN Rail Terminal Block	X	X	X
10	8611-144	DIN Rail End Clamp	X	X	X
11	8611-194	2 Position Jumper	X	X	X
12	8611-203	10 Position Jumper	X	X	X
13	8401-034	Contactora 2-Pole 40 Amp (Heat)	X	X	X
14	8611-147	3-Pin Circuit Board Connector	3	3	3
15	8611-148	4-Pin Circuit Board Connector	3	3	3
16	8611-183	2-Pin Circuit Board Connector	2	2	2
17	8611-192	3-Pin Circuit Board Connector	1	1	1
18	8611-185	8-Pin Circuit Board Connector	1	1	1
19	8611-149	9-Pin Circuit Board Connector	1	1	1
20	8611-208	3 Position Jumper	2	2	2
21	517-401	Control Panel	X		
21	517-400	Control Panel		X	X
22	127-556	Circuit Breaker Base	X	X	X
23	8550-008	Capacitor Bracket 2.5"	X		
23	8550-007	Capacitor Bracket 2.0"			X
23	8550-006	Capacitor Bracket 1.5"		X	
NS	8301-088	USB A to Micro B 90° Cable	X	X	X

* Replacement part will have a letter attached to the end of the part number to designate software version (Example: 8301-068-002**A**). A software upgrade of all PLCs onsite (units and controllers) should accompany any PLC replacement. Latest revisions of software, change log and instructions are available on the Bard website at <http://www.bardhvac.com/software-download/>

① uPC3 Core 0 PLC controller boards can be identified by the use of a white software version label on the board and a white PLC part number label located on the side of the board. uPC3 Core 2 PLC controller boards can be identified by the use of a yellow software version label on the board, a yellow PLC part number label located on the side of the board and a yellow Core Type 2 label located on the capacitor of the board power supply.

② Capacitor mounted to HR35/36BPA control panel

Wiring diagram reference listed under **HEATER PACKAGES** on pages 17 and 18

CONTROL PANEL - 3 PHASE

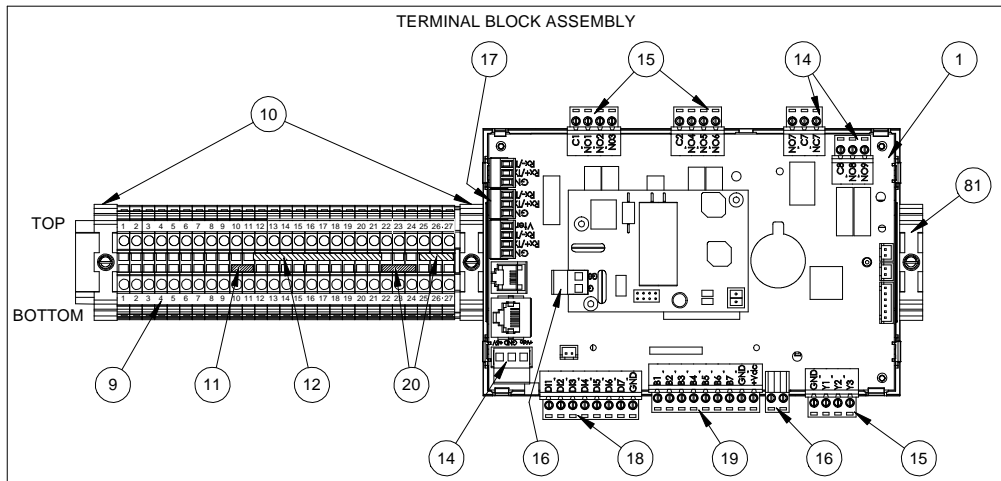
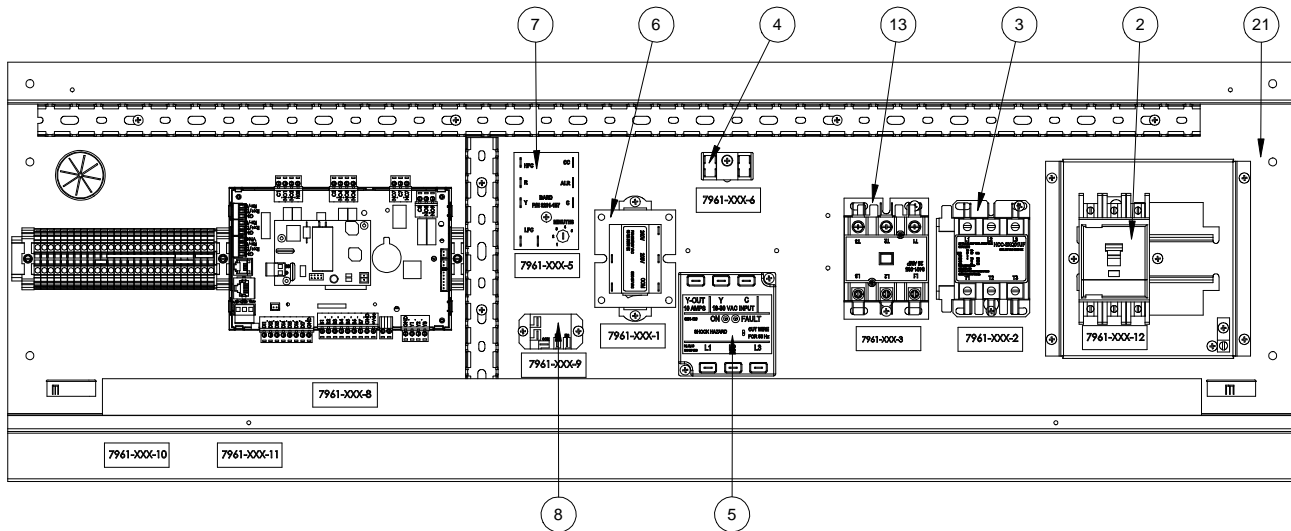

SEXP-891

CONTROL PANEL – 3 PHASE

Dwg No.	Part Number	Description	HR35BPB	HR36BPB	HR58BPB
1	8301-068-002*	uPC3 Core 0 FUSION-TEC HR ①	X	X	X
1	8301-096-001*	uPC3 Core 2 FUSION-TEC HR ①	X	X	X
2	8615-099	Circuit Breaker 45A 3-Pole			
2	8615-100	Circuit Breaker 30A 3-Pole	X	X	X
3	8401-037	Contactor 3-Pole 30 Amp (Compressor)	X	X	X
4	8607-017	Terminal Block 240V 2 Terminal	X	X	X
5	8201-126	3 Phase Line Monitor 50/60 HZ	X	X	X
6	8407-065	Transformer 208/240-24 75VA	X	X	X
7	8201-164	Compressor Control Module	X	X	X
8	8201-130	Relay Pilot Duty	X	X	X
9	8611-150	DIN Rail Terminal Block	X	X	X
10	8611-144	DIN Rail End Clamp	X	X	X
11	8611-194	2 Position Jumper	X	X	X
12	8611-203	10 Position Jumper	X	X	X
13	8401-035	Contactor 3-Pole 25 Amp (Heat)	X	X	X
14	8611-147	3-Pin Circuit Board Connector	3	3	3
15	8611-148	4-Pin Circuit Board Connector	3	3	3
16	8611-183	2-Pin Circuit Board Connector	2	2	2
17	8611-192	3-Pin Circuit Board Connector	1	1	1
18	8611-185	8-Pin Circuit Board Connector	1	1	1
19	8611-149	9-Pin Circuit Board Connector	1	1	1
20	8611-208	3 Position Jumper	2	2	2
21	517-400	Control Panel		X	X
21	517-401	Control Panel	X		
22	127-556	Circuit Breaker Base	X	X	X
NS	8301-088	USB A to Micro B 90° Cable	X	X	X

* Replacement part will have a letter attached to the end of the part number to designate software version (Example: 8301-068-002**A**). A software upgrade of all PLCs onsite (units and controllers) should accompany any PLC replacement. Latest revisions of software, change log and instructions are available on the Bard website at <http://www.bardhvac.com/software-download/>

① uPC3 Core 0 PLC controller boards can be identified by the use of a white software version label on the board and a white PLC part number label located on the side of the board. uPC3 Core 2 PLC controller boards can be identified by the use of a yellow software version label on the board, a yellow PLC part number label located on the side of the board and a yellow Core Type 2 label located on the capacitor of the board power supply.

Wiring diagram reference listed under **HEATER PACKAGES** on page 18

BLOWER ASSEMBLY COMPONENTS - HR35BP*

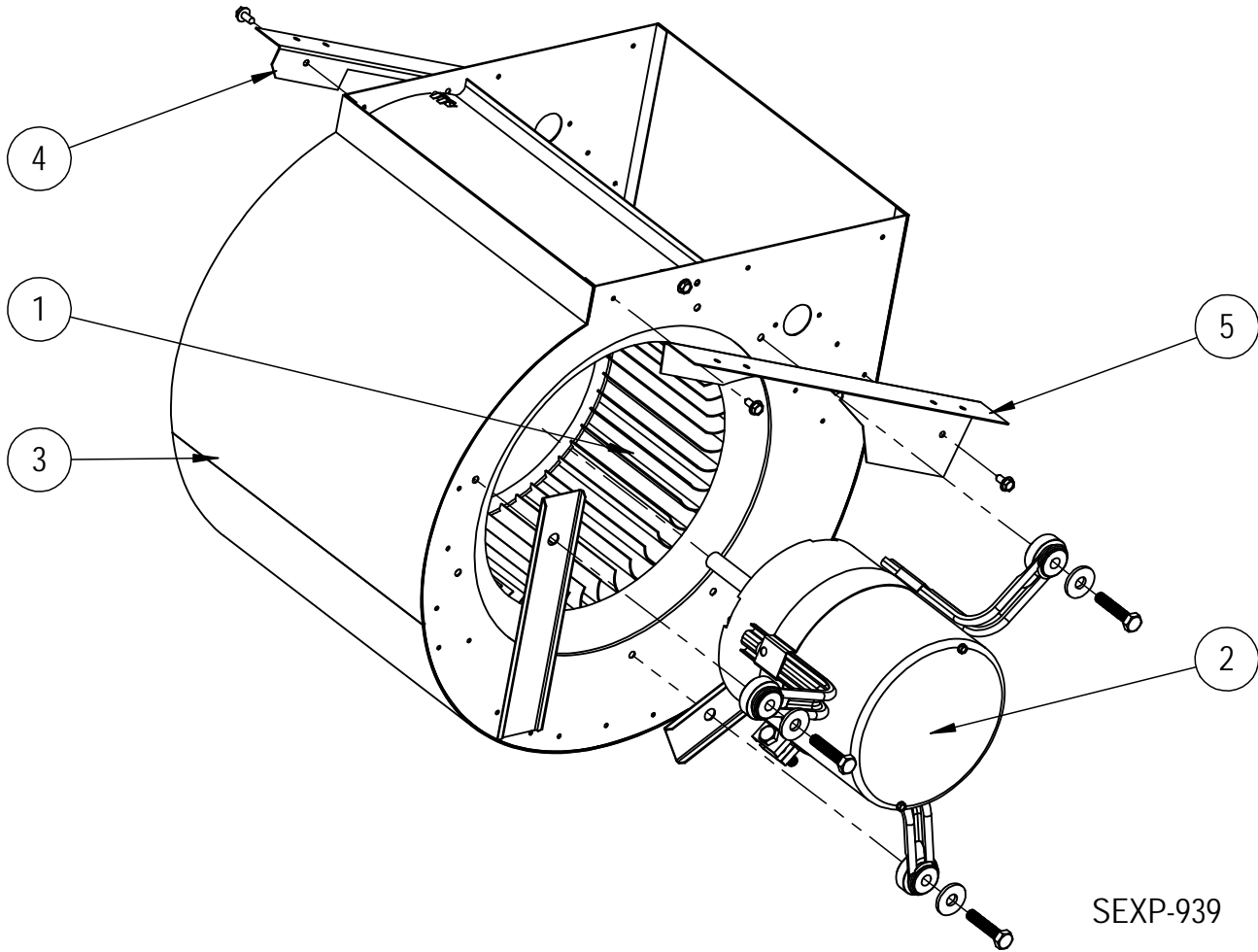

Drawing No.	Part Number	Description	900-362
1	5152-014	Blower Wheel	X
2	S8106-051-0154	1/3 HP Programmed Motor	X
2	C8106-051-0154	1/3 HP Control Only Replacement	X
3	151-126	Housing	X
4	105-1435	Left Mounting Angle	X
5	105-1443	Right Mounting Angle	X

BLOWER ASSEMBLY COMPONENTS - HR36BP*

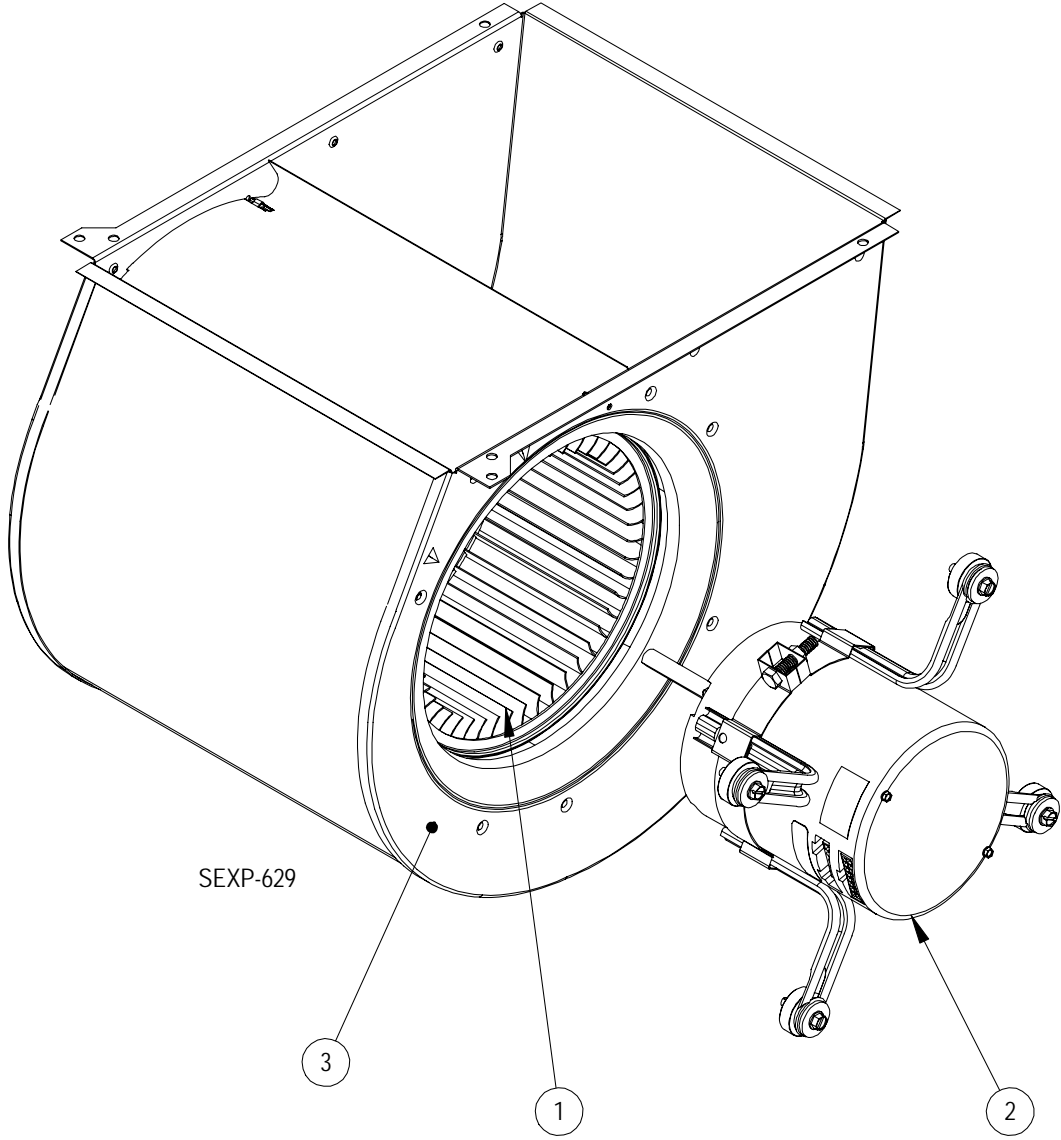

Drawing No.	Part Number	Description	5154-002-0146
1	5152-049	Blower Wheel	X
2	S8105-059-0146	1/3 HP Programmed Motor	X
3	151-122	Housing	X
NS	C8105-059-0146	1/3 HP Control Only Replacement	X
NS	3000-1578	0-10VDC Adapter Wire	X

BLOWER ASSEMBLY COMPONENTS - HR58BP*

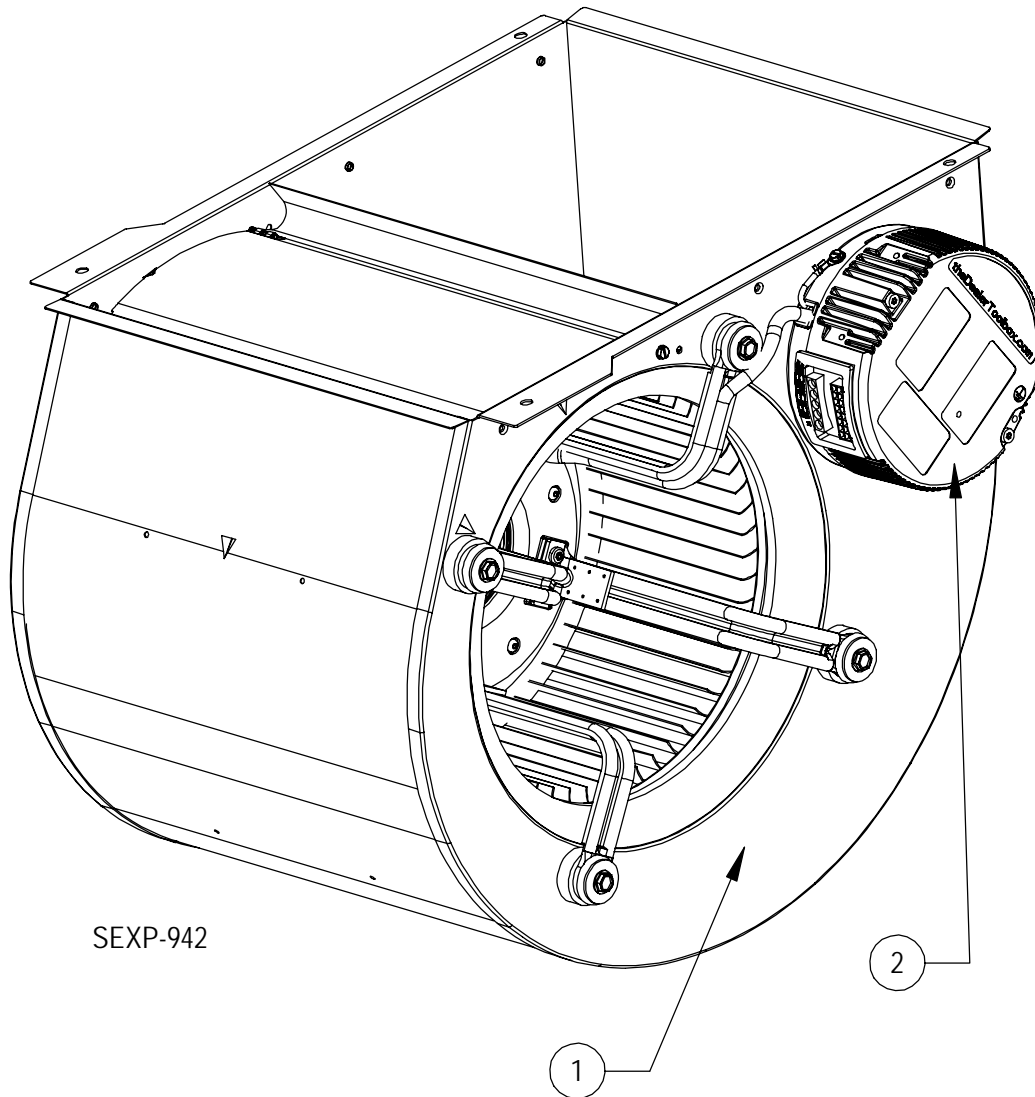

Drawing No.	Part Number	Description	
1	5154-007-0142	Complete Blower Wheel	X
2	C5154-007-0142	3/4 HP Control Only Replacement	X
NS	3000-1578	0-10VDC Adapter Wire	X

5154-007-0142

HEATER PACKAGES – HR35BP*

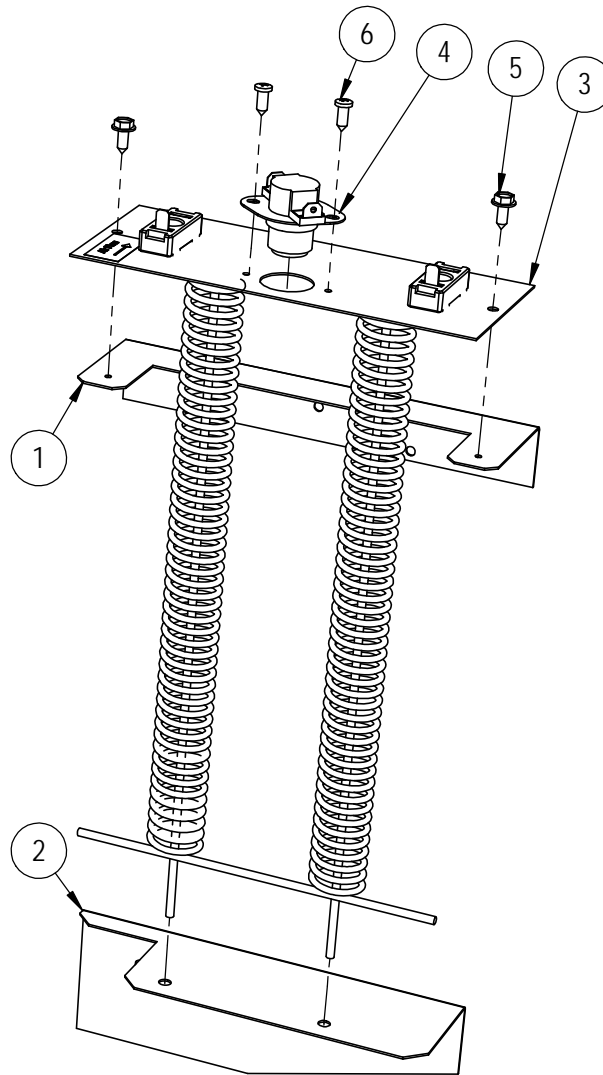

SEXP-940

Dwg No.	Part Number	Description	HR35BPA0Z	HR35BPA01	HR35BPA05	HR35BPB0Z	HR35BPB05
1	113-709	Top Heater Support		X	X		X
2	113-710	Lower Heater Support		X	X		X
3	8604-150	Heat Strip 1.5KW 240V 2 Term		X			
3	8604-148	Heat Strip 5.0KW 240V 2 Term			X		
3	8604-149	Heat Strip 6.0KW 240V 3 PH					X
4	8402-190	Limit Control 130P/150BU		1	1		1
5	1012-065	Screw, Type AB PZPNHD #8-18X3/8		6	6		6
6	1012-086	Screw, Type AB HXWHD #10-16X1/2		6	6		6
NS	4208-100	Wiring Diagram	X				
NS	4208-101	Wiring Diagram		X	X		
NS	4208-200	Wiring Diagram				X	
NS	4208-201	Wiring Diagram					X

HEATER PACKAGES – HR36BP*/HR58BP*

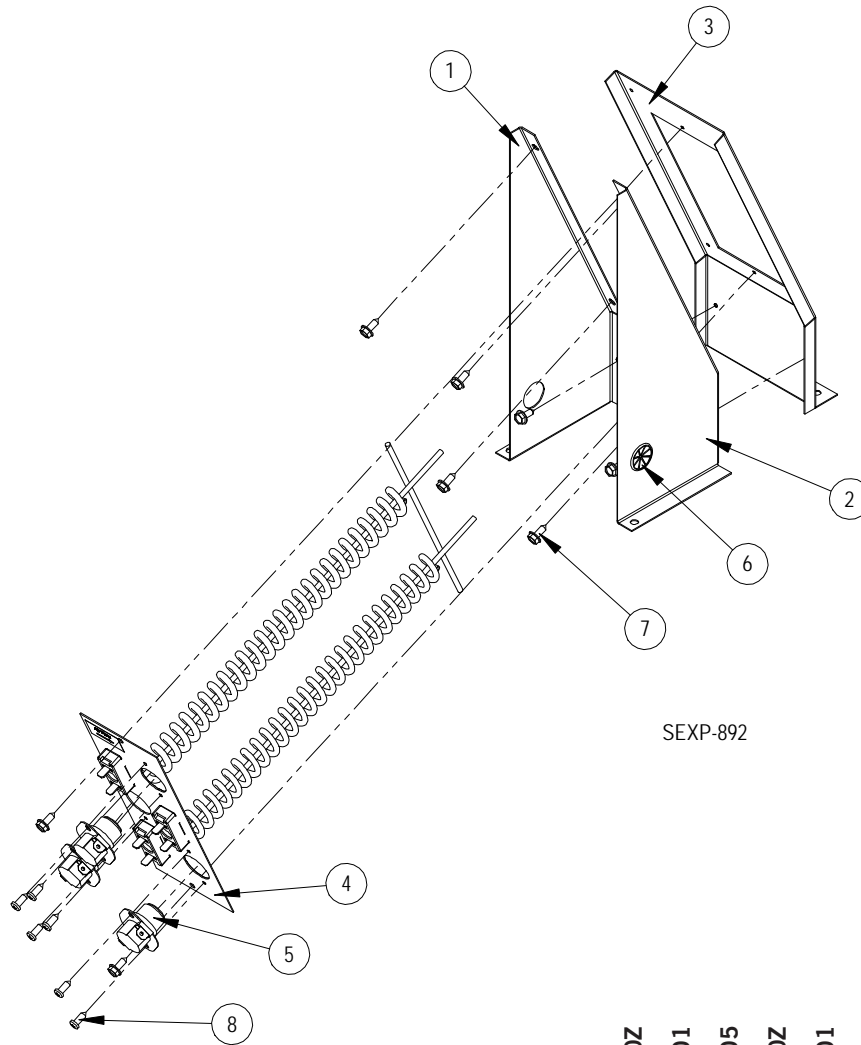

SEXP-892

Dwg No.	Part Number	Description	HR36BPA0Z	HR36BPA01	HR36BPA05	HR58BPA0Z	HR58BPA01	HR58BPA05	HR36BPB0Z	HR36BPB05	HR58BPB0Z	HR58BPB05
1	113Y671	Left Heater Support		X	X		X	X		X		X
2	113X672	Right Heater Support		X	X		X	X		X		X
3	113-668	Heater Bracket Front		X	X		X	X		X		X
4	8604-150	Heat Strip 1.5KW 240V 2 Term		X			X					
4	8604-148	Heat Strip 5.0KW 240V 2 Term			X			X				
4	8604-149	Heat Strip 6.0KW 240V 3PH								X		X
5	8402-190	Limit Control 130P/150BU		1	1		1	1		3		3
6	8611-016	Universal Bushing		X	X		X	X		X		X
7	1012-065	Screw, Type AB PZPNHD #8-18X3/8		6	6		6	6		6		6
8	1012-086	Screw, Type AB HXWHD #10-16X1/2		8	8		8	8		8		8
NS	4208-100	Wiring Diagram	X			X						
NS	4208-101	Wiring Diagram		X	X		X	X				
NS	4208-200	Wiring Diagram							X		X	
NS	4208-201	Wiring Diagram								X		X

FREECOOLING DAMPER MOTOR

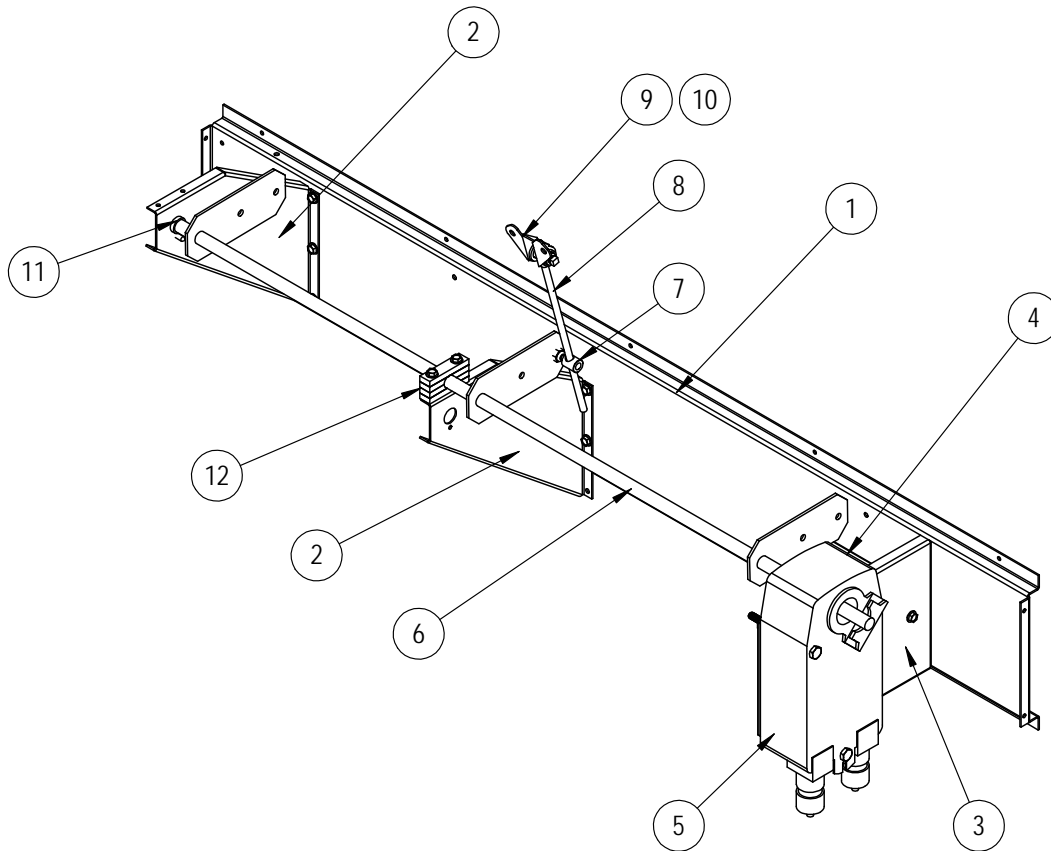

SEXP-902

Dwg. No.	Part Number	Description	HR35BP	HR36BP	HR58BP
1	103-537	Actuator Support Channel	X		
1	103-538	Actuator Support Channel		X	X
2	113-712	Rod Support Bracket	X		
3	113-711	Actuator Bracket	X		
4	141-326	Gusset	X		
5	8602-093	90 in/lb Actuator	X		
6	8602-101	Actuator Drive Rod Assembly		X	X
6	8602-102	Actuator Drive Rod Assembly	X		
7	8602-008	Ball Joint	X		
8	8602-042	1/4" x 6" Rod	X		
8	8602-091	1/4" x 8-1/2" Rod		X	X
9	8602-040	Butterfly Bracket	X		
10	1012-348	1/2" x 3/4" Nylon Flat Washer	2		
11	8602-052	1/2" I.D. Bronze Bushing	X		
12	8602-087	Cradle Bushing	2		

ANTI-THEFT KIT (OPTIONAL)

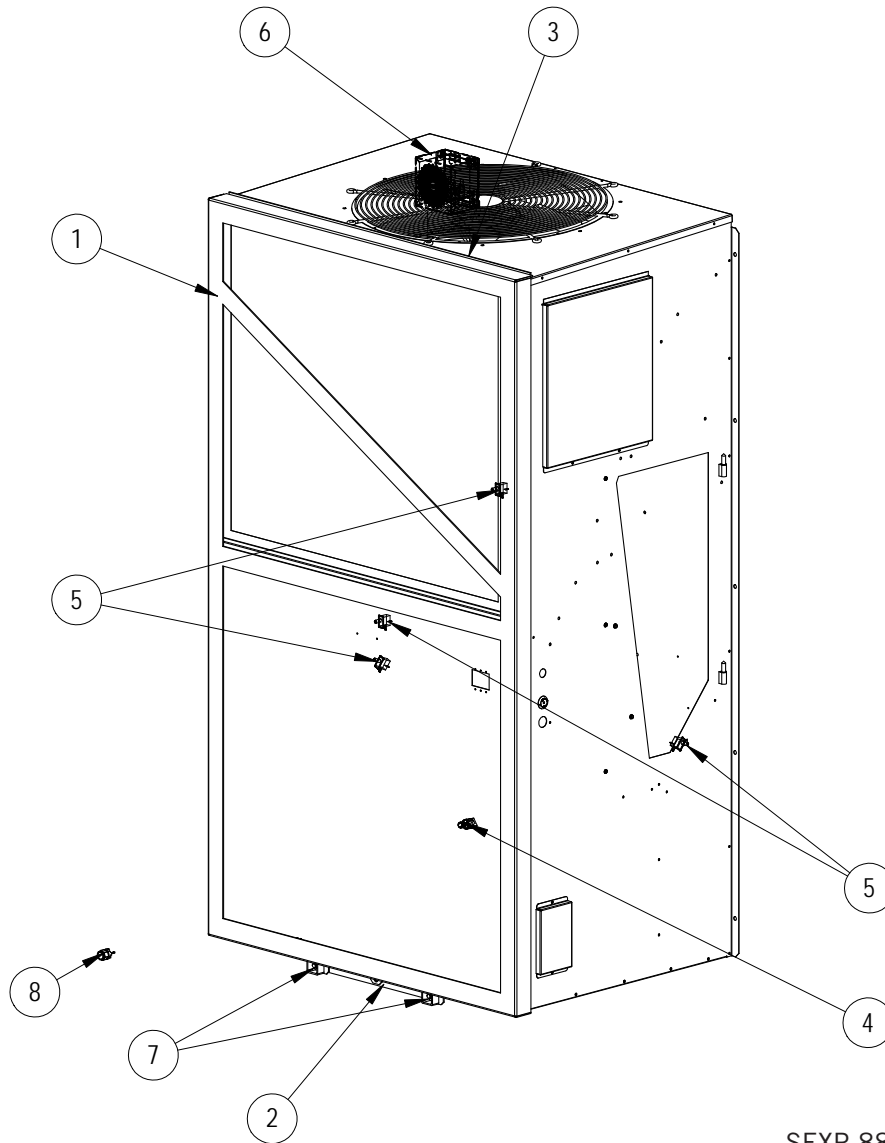

SEXP-888A

Dwg No.	Part Number	Description	HR35BP*	HR36BP*	HR58BP*
1	9050-004	Frame Assembly		X	X
1	9050-008	Frame Assembly	X		
2	9050-005	Base Bracket	X	X	X
3	9050-006	Top Bracket		X	X
3	9050-007	Top Bracket	X		
4	8406-135	Low Pressure Switch	X	X	X
5	8406-156	Panel Switch	4	4	4
6	910-2038	Speaker Assembly	X	X	X
7	1012-346	Tri-Groove Nut	2	2	2
8	2151-022	Tri-Groove Socket – Key	X	X	X