REPLACEMENT PARTS MANUAL

Commercial Room Ventilator with Spring Return and Exhaust

Models:

FEMA 2 Ton Vent: 920-0517

FEMA 3 Ton Vent: 920-0518

General Notes

- Revised and/or additional pages may be issued from time to time.
- A complete and current manual consists of pages shown in the following contents section.

Important

- Contact the installing and/or local distributor for all parts requirements. Make sure to have the complete model and serial number available from the unit rating plates.

Contents

<u>Description</u>	<u>Page</u>
FEMA Commercial Room Ventilator	
♦ Exploded View	2
♦ Usage List	3
Blade Assembly	
♦ Exploded View	4
♦ Usage List	5
FEMA Controls	
♦ Exploded View	6
♦ Usage List	6

BMC, Inc.
Bryan, Ohio 43506

Manual: 2110-1556B
Supersedes: 2110-1556A
Date: 6-9-23

FEMA COMMERCIAL ROOM VENTILATOR

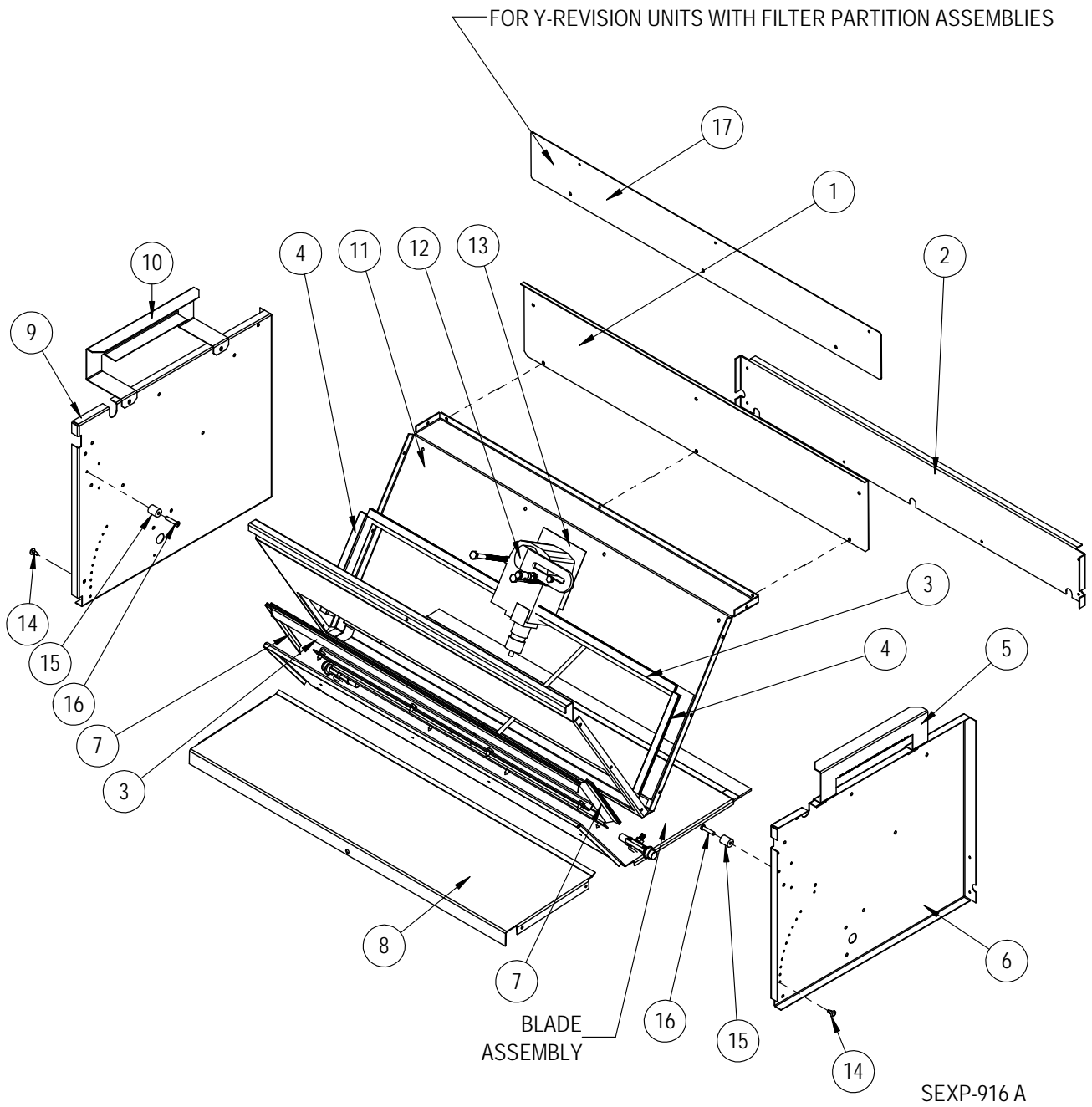

FEMA COMMERCIAL ROOM VENTILATOR

Drawing No.	Part No.	Description	920-0517	920-0518
1	137-748	Upper Rear Fill	X	
1	137-746	Upper Rear Fill		X
2	137-874	Lower Rear Fill	X	
2	137-873	Lower Rear Fill		X
3	1921-067-2006	Damper Blade Seal	2	
3	1921-067-2506	Damper Blade Seal		2
4	1921-067-0606	Damper Blade Seal	2	2
5	113-543	Short Filter Bracket	X	X
6	101x1035	Right CRV Side	X	X
7	1921-067-0410	Damper Blade Seal	2	2
8	137-869	Lower Front Partition	X	
8	137-829	Lower Front Partition		X
9	101Y1035	Left CRV Side	X	X
10	113-542	Long Filter Bracket	X	X
11	139-387	Partition	X	
11	139-388	Partition		X
12	8602-094	Actuator	X	X
13	128-027	Actuator Spacer	X	X
14	8611-059	Canoe Clip	2	2
15	1012-192	Nylon Spacer	2	2
16	1012-074	Screw #8-18x1	2	2
17	136-1013BX	Return Fill Plate		X
17	136-1014BX	Return Fill Plate	X	
NS	S136-1004	Condenser Cover Plate	X	
NS	S136-1005	Condenser Cover Plate		X
NS	7003-076	Mist Filter 11-3/4"x20-7/8"x1/2"	X	
NS	7003-075	Mist Filter 11-3/4"x26-1/4"x1/2"		X
NS	S553-750-X	Vent Option Door	X	
NS	S553-754-X	Vent Option Door		X

NS = Not Shown

BLADE ASSEMBLY

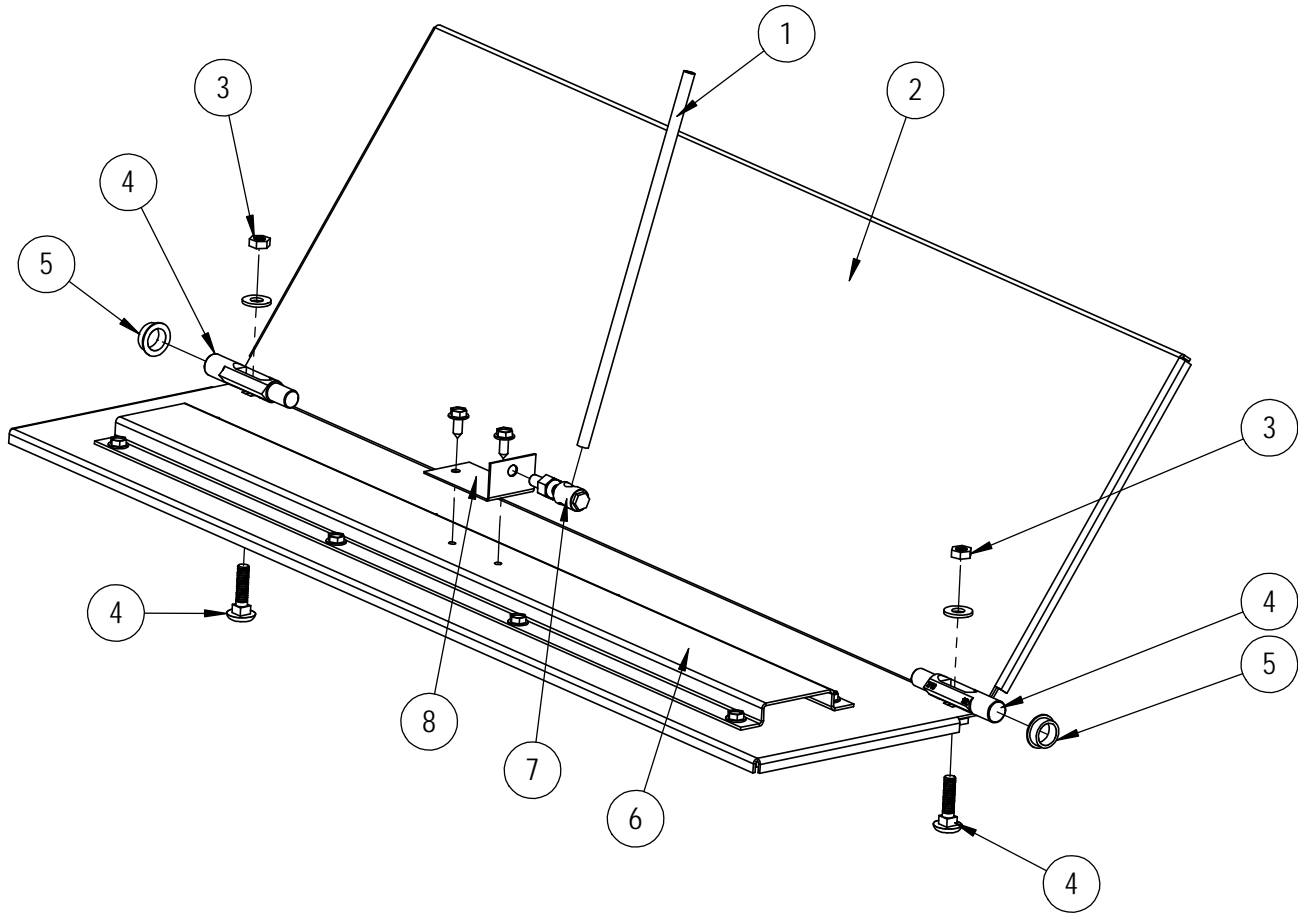

SEXP-927

BLADE ASSEMBLY

Drawing No.	Part No.	Description	920-0517	920-0518
1	8602-077	1/4 x 9" Rod	X	X
2	139-355	Blade	X	
2	139-352	Blade		X
3	1012-221	1/4-20 Hex Flange Nut	2	2
4	8602-038	Damper Pin with Hardware	2	2
5	8602-052	1/2" Bronze Bushing	X	X
6	141-433	Blade Support	X	
6	141-430	Blade Support		X
7	8602-008	Ball Joint	X	X
8	105-1444	Bracket	X	X

FEMA CONTROLS

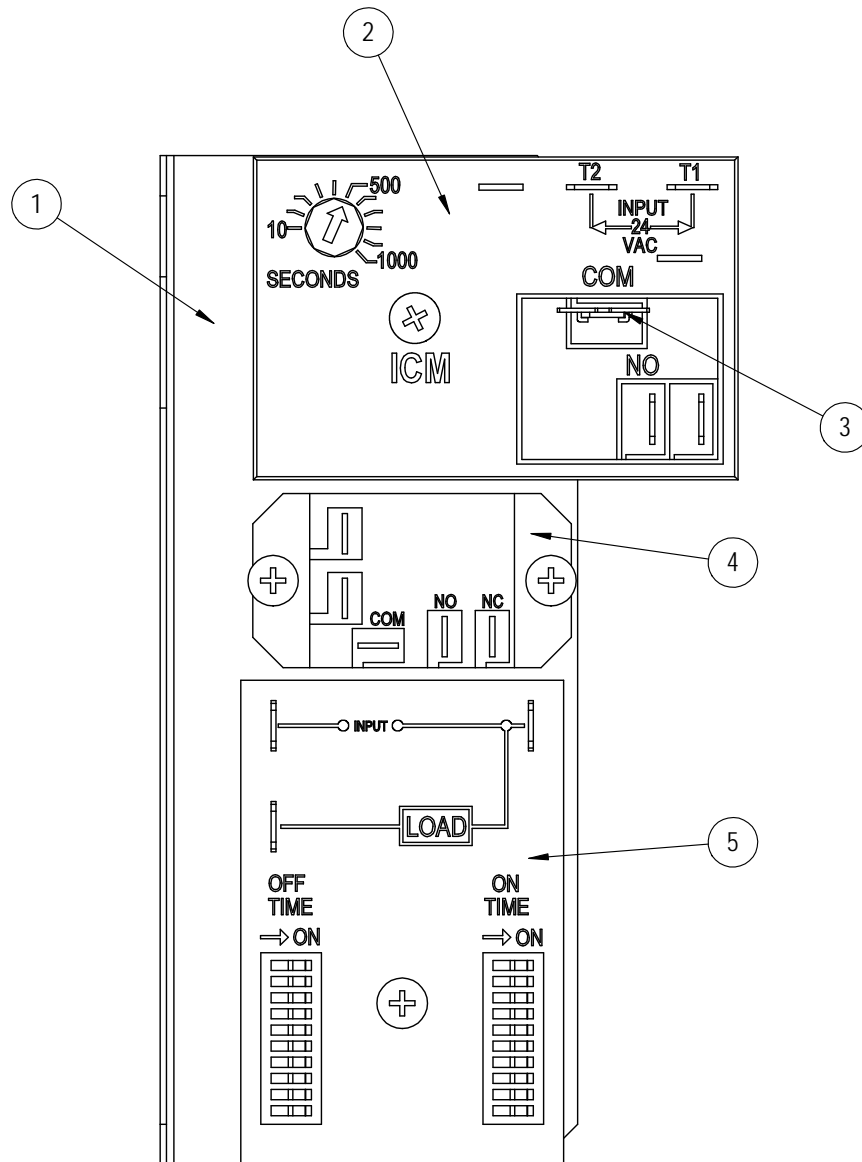

SEXP-1021

Drawing No.	Part No.	Description	920-0517	920-0518
1	113-827	Vent Timer Bracket	X	X
2	8201-133	Time Delay Relay	X	X
3	8611-009	Multiplier	X	X
4	8201-130	Pilot Duty Relay	X	X
5	8201-135	Relay Cycle Timer	X	X
NS	3000-1684	Wire Assembly (w/12-Pin Plug)	X	X