REPLACEMENT PARTS MANUAL

Wall Mount Heat Pump

Models:

J42HC-A	J48HC-A	J60HC-A
J42HC-B	J48HC-B	J60HC-B
J42HC-C	J48HC-C	J60HC-C

Contents

Description	Page
External Parts	
♦ Exploded View	2
♦ Usage List	3
Internal Parts	
♦ Exploded View	4
♦ Usage List	5
Functional Components	
♦ Exploded View	6
♦ Usage List	7
Control Panel	
♦ Layout View	8
♦ Usage List	9
Blower Assembly	
♦ Exploded View	10
♦ Usage List	10

General Notes

- Revised and/or additional pages may be issued from time to time.
- A complete and current manual consists of pages shown in the following contents section.

Important

- Contact the installing and/or local Bard distributor for all parts requirements. Make sure to have the complete model and serial number available from the unit rating plates.



Manual: 2110-1566D
Supersedes: 2110-1566C
Date: 1-12-22

EXTERNAL PARTS

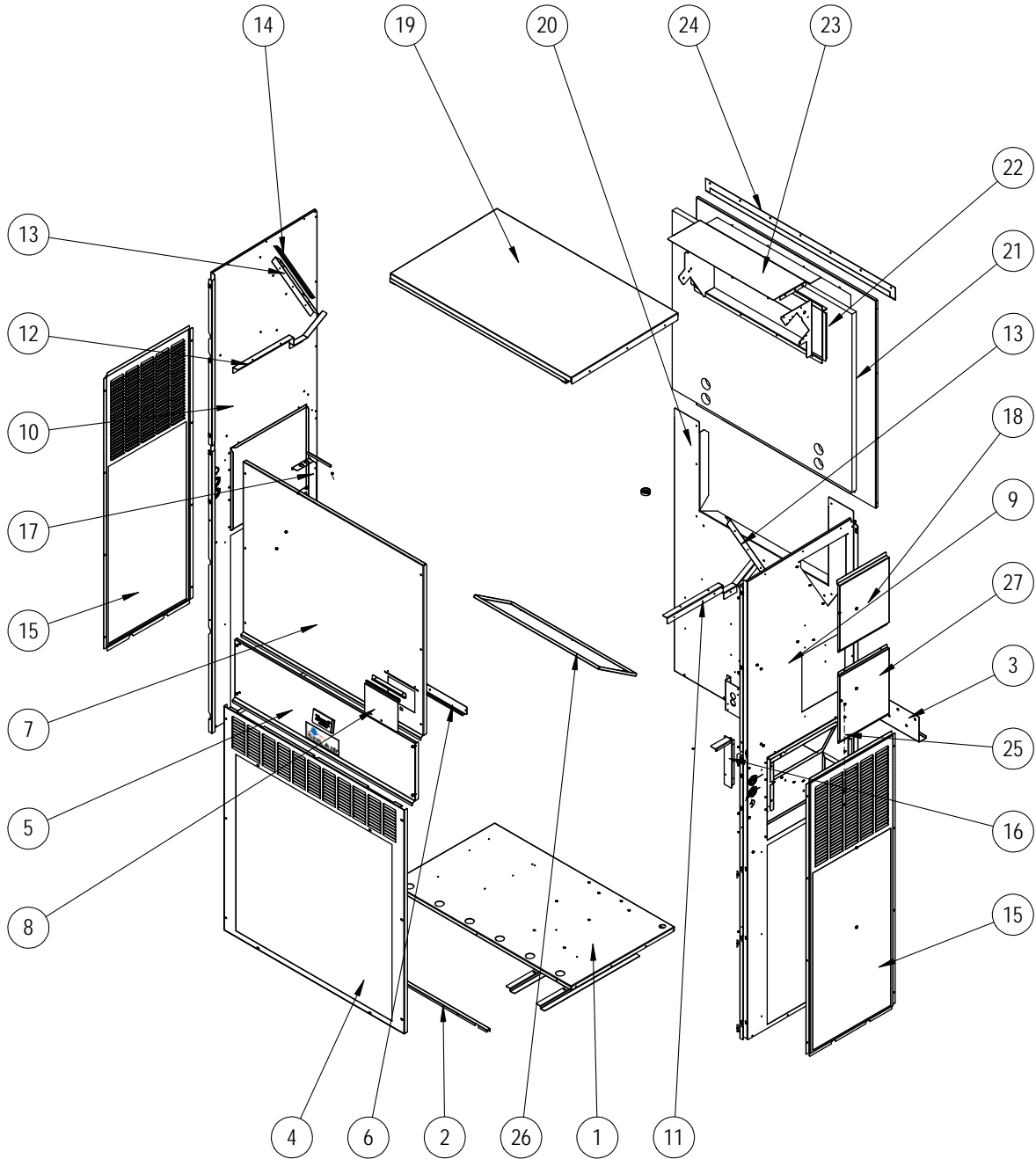

SEXP-932 B

EXTERNAL PARTS

Dwg No.	Part Number	Description	J42HC-A, B, C	J48HC-A, B, C	J60HC-A, B, C
1	S127-574	Unit Base	X	X	X
2	113-762	Front Base Bracket	X	X	X
3	113-140	Bottom Mounting Bracket	X	X	X
4	119-125-X	Front Grille	X	X	
4	119-127-X	Front Grille			X
5	S533-352-X	Control Panel Cover (Outer)	X	X	X
6	S165-608-X	Rain Channel	X	X	X
7	S515-323-X	Upper Front	X	X	
7	S515-324-X	Upper Front			X
8	153-717-X	Disconnect Access Door	X	X	X
9	S501-1127-X	Right Side	X	X	
9	S501-1130-X	Right Side			X
10	501-1054-X	Left Side	X	X	
10	501-1056-X	Left Side			X
11	105X1454	Right Support Angle	X	X	X
12	105Y1454	Left Support Angle	X	X	X
13	105-1457	Coil Support	2	2	
13	105-1455	Coil Support			2
14	147-055	Coil Support Offset	X	X	
14	147-054	Coil Support Offset			X
15	119-126-X	Side Grille	2	2	
15	119-128-X	Side Grille			2
16	105-1450	Right Control Panel Angle	X	X	X
17	105-1451	Left Control Panel Angle	X	X	X
18	S543-221-X	Heater Access Cover	X	X	X
19	507-382-X	Top	X	X	X
20	109-412	Lower Back	X	X	
20	109-414	Lower Back			X
21	S509-411	Upper Back	X	X	
21	S509-413	Upper Back			X
22	S111-299	Outlet Air Frame Assembly	X	X	X
23	535-129	Heat Shield	X	X	X
24	113-150-X	Top Rain Flashing	X	X	X
25	539-406	Fresh Air Damper Assembly	X	X	X
26	543-220	Exhaust Blank Off Plate	X	X	X
27	S543-248-X	Access Cover	X	X	X

INTERNAL PARTS

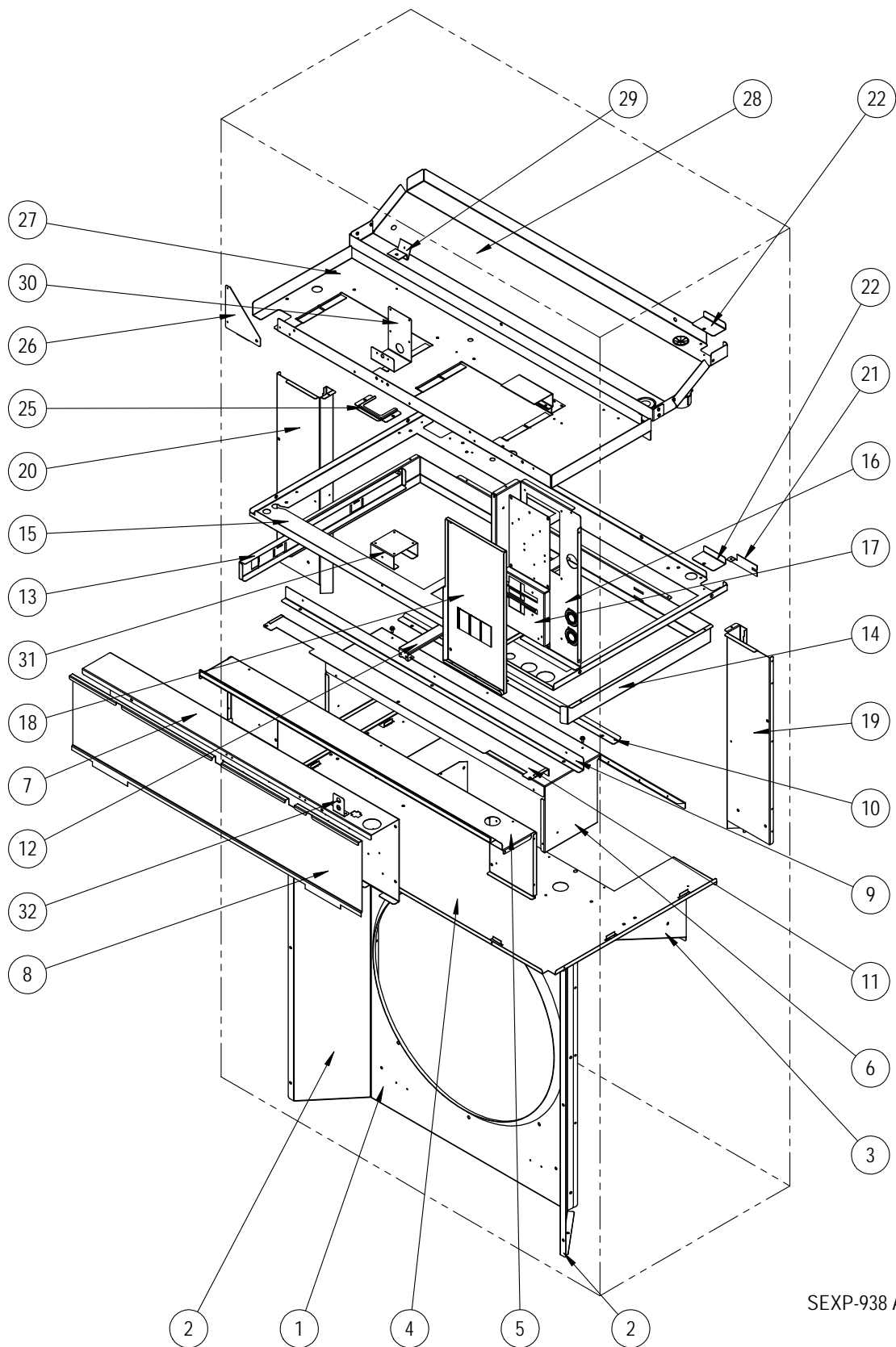

SEXP-938 A

INTERNAL PARTS

Dwg No.	Part Number	Description	J42HC-A, B	J42HC-C	J48HC-A, B	J48HC-C	J60HC-A, B	J60HC-C
1	125-089	Fan Shroud	X	X	X	X		
1	125-091	Fan Shroud					X	X
2	S125-090	Fan Shroud Side Access Cover	2	2	2	2		
2	S125-092	Fan Shroud Side Access Cover					2	2
3	121-586	Condenser Partition Insert	X	X	X	X	X	X
4	121-585	Condenser Partition	X	X	X	X	X	X
5	521-630	Front Exhaust Partition	X	X	X	X	X	X
6	521-587	Exhaust Partition	X	X	X	X	X	X
7	Control Panel Assy.	See Control Panel Assy. Drawing & Parts List	X	X	X	X	X	X
8	S133-330	Control Panel Cover (Inner)	X	X	X	X	X	X
9	105-1453	Front Vent Guide Rail	X	X	X	X	X	X
10	105-1452	Vent Guide Rail	X	X	X	X	X	X
11	S135-409	Field Wire Shield	X	X	X	X	X	X
12	131-168	Filter Support Bracket	2	2	2	2	2	2
13	131-170	Filter Slide	X	X	X	X	X	X
14	131-169	Filter Rack Frame	X	X	X	X	X	X
15	121-583	Filter Partition	X	X	X	X	X	X
16	117-412	Upper Control Panel	X	X	X	X	X	X
17	127-575	Circuit Breaker Base	X		X		X	
17	127-585	Circuit Breaker Base - 460V		X		X		X
18	S133-303	Upper Control Panel Cover	X		X		X	
18	S133-304	Upper Control Panel Cover - 460V		X		X		X
19	135X393	Right Copper Chase	X	X	X	X	X	X
20	135Y393	Left Copper Chase	X	X	X	X	X	X
21	113-796	Copper Retainer	2	2	2	2	2	2
22	137-920	Copper Fill Plate	2	2	2	2	2	2
25	113-765	Grommet Retainer	X	X	X	X	X	X
26	141-492	Blower Partition Support	X	X	X	X	X	X
27	121-582	Blower Partition	X	X	X	X	X	X
28	523-161	Drain Pan	X	X	X	X	X	X
NS	113-809	Heating Expansion Valve Bracket	X	X	X	X	X	X
NS	113-381	TXV Bulb Bracket	X	X	X	X	X	X

FUNCTIONAL COMPONENTS

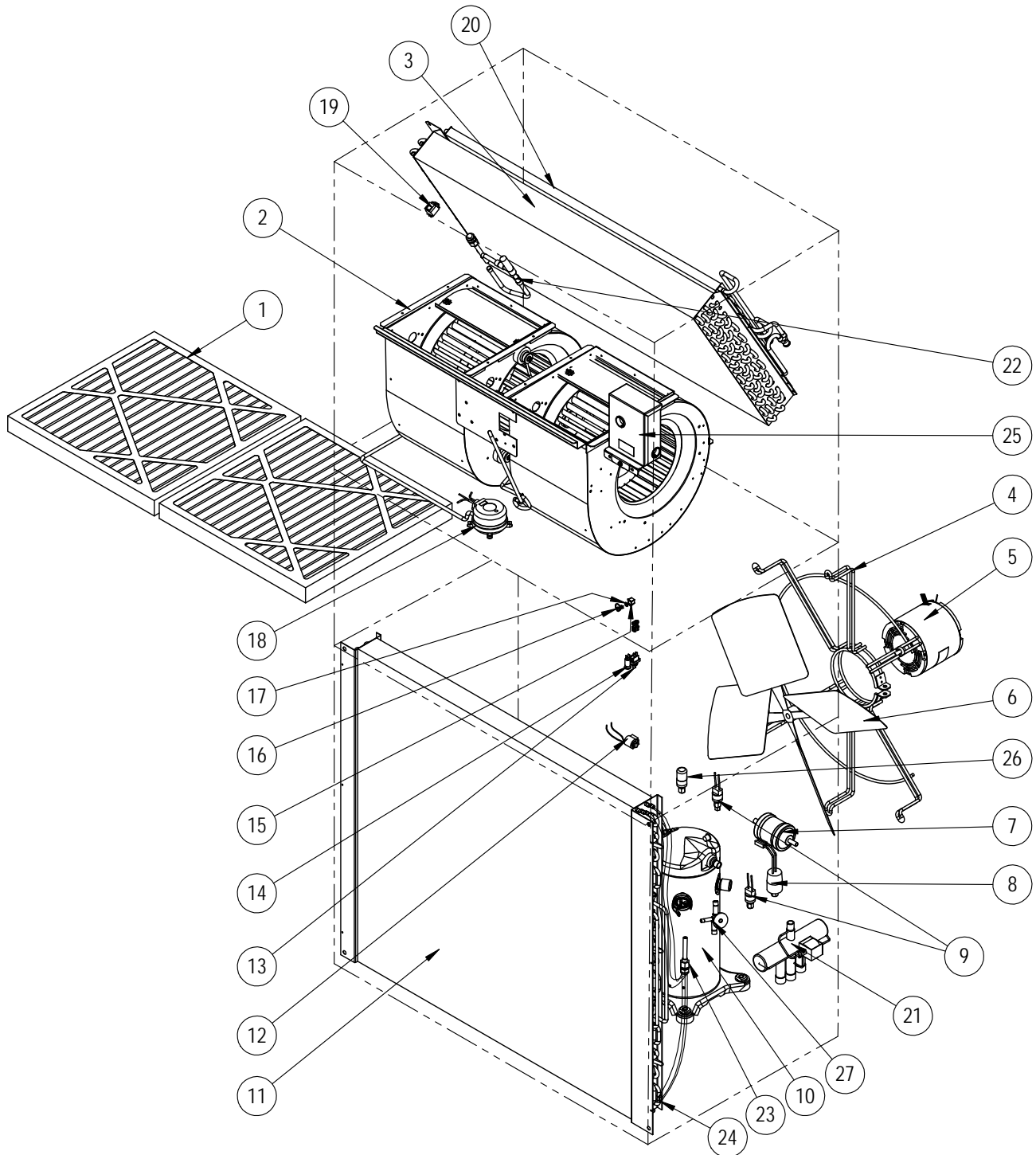

SEXP-1001 A

FUNCTIONAL COMPONENTS

Dwg No.	Part Number	Description	J42HC-A	J42HC-B	J42HC-C	J48HC-A	J48HC-B	J48HC-C	J60HC-A	J60HC-B	J60HC-C
1	7004-052	Air Filter 2" Merv 8 (20 x 20 x 2)	2	2	2	2	2	2	2	2	2
2	S900-366-002	Blower Assembly	X	X							
2	S900-367-002	Blower Assembly - 460V			X						
2	S900-368-004	Blower Assembly				X	X				
2	S900-369-004	Blower Assembly - 460V						X			
2	S900-368-005	Blower Assembly							X	X	
2	S900-369-005	Blower Assembly - 460V									X
3	917-0403BX	Indoor Coil w/Distributor Assy.	X	X	X						
3	917-0407BX	Indoor Coil w/Distributor Assy.				X	X	X			
3	917-0411BX	Indoor Coil w/Distributor Assy.							X	X	X
4	8200-004	Fan Motor Mount	X	X	X	X	X	X	X	X	X
5	8105-068	Condenser Motor	X	X		X	X		X	X	
5	8105-071	Condenser Motor - 460V			X			X			X
6	5151-060	Fan Blade	X	X	X	X	X	X	X	X	X
7	5201-020	Filter Drier	X	X	X	X	X	X	X	X	X
8	CMH-35	Low Ambient Control (LAC) Kit = #8, 12, 19	X	X	X	X	X	X	X	X	X
9	8406-142	High Pressure Switch	X	X	X	X	X	X	X	X	X
9	8406-135	Low Pressure Switch	X	X	X	X	X	X	X	X	X
10	8000-349	Compressor	X								
10	8000-350	Compressor		X							
10	8000-351	Compressor			X						
10	8000-332	Compressor				X					
10	8000-333	Compressor					X				
10	8000-334	Compressor						X			
10	8000-421	Compressor							X		
10	8000-422	Compressor								X	
10	8000-423	Compressor									X
11	917-0413	Outdoor Coil (Includes Distributor)	X	X	X						
11	917-0415	Outdoor Coil (Includes Distributor)				X	X	X			
11	917-0417BX	Outdoor Coil (Includes Distributor)							X	X	X
15	1171-023	1/4 Turn Receptacle	X	X	X	X	X	X	X	X	X
16	1171-022	1/4 Turn Fastener	X	X	X	X	X	X	X	X	X
17	1171-024	1/4 Turn Retainer	X	X	X	X	X	X	X	X	X
21	5650-040	Reversing Valve	X	X	X	X	X	X	X	X	X
22	800-0465	Distributor Assembly - Indoor Coil	X	X	X						
22	800-0468	Distributor Assembly - Indoor Coil							X	X	X
22	800-0488	Distributor Assembly - Indoor Coil				X	X	X			
23	800-0424	Distributor Assembly - Outdoor Coil	X	X	X						
23	800-0445	Distributor Assembly - Outdoor Coil							X	X	X
23	800-0467	Distributor Assembly - Outdoor Coil				X	X	X			
24	8620-044	Defrost Thermistor Sensor							X	X	X
24	8620-225	Defrost Thermistor Sensor Kit	X	X	X	X	X	X			
27	5651-210	Heating Expansion Valve	X	X	X						
27	5651-211	Heating Expansion Valve				X	X	X	X	X	X
NS	5650-042	Rev. Valve Solenoid, Red Casing (Ranco)	X	X	X	X	X	X	X	X	X
NS	5650-046	Rev. Valve Solenoid, Black Casing (San Hua)	X	X	X	X	X	X	X	X	X
NS	5451-024	Tubing Isolation Grommet	2	2	2	2	2	2	2	2	2
NS	6031-009	Coremax Valve Core	2	2	2	2	2	2	2	2	2
NS	1171-070	Control Panel Door Clip	4	4	4	4	4	4	4	4	4
NS	1171-068	Control Panel Door Screw	4	4	4	4	4	4	4	4	4
NS	1171-069	Control Panel Door Screw Retainer	4	4	4	4	4	4	4	4	4
NS	5650-054	Molded Plug for Rev/Dehum Valves	X	X	X	X	X	X	X	X	X

CONTROL PANEL

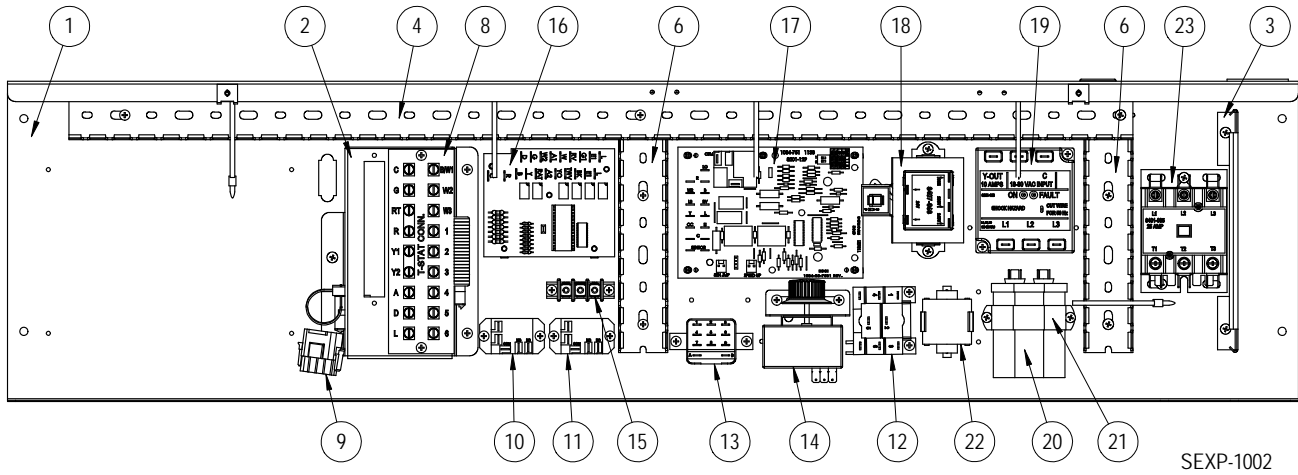

SEXP-1002

CONTROL PANEL

Dwg No.	Part Number	Description	J42HC-A	J42HC-B	J42HC-C	J48HC-A	J48HC-B	J48HC-C	J60HC-A	J60HC-B	J60HC-C
1	117-411	Control Panel	X	X	X	X	X	X	X	X	X
2	S910-2061	Complete Low Voltage Box Assembly (Sheet metal, Terminal Strip, & Wire Harness)	X	X	X	X	X	X	X	X	X
3	135-394	Wire Shield	X	X	X	X	X	X	X	X	X
4	8611-244-3208	Cable Duct - 32.5"	X	X	X	X	X	X	X	X	X
6	8611-244-0608	Cable Duct - 6.5"	2	2	2	2	2	2	2	2	2
8	8607-063	Low Voltage Terminal Strip - 18 term.	X	X	X	X	X	X	X	X	X
9	3000-1524	Vent Jumper Plug (used when no vent option)	X	X	X	X	X	X	X	X	X
11	8201-130	Blower Speed Relay	X	X	X	X	X	X	X	X	X
12	8201-086	OD T-Stat/LAC Relay (LAC Kit = CMH-35)	X	X	X	X	X	X	X	X	X
15	8607-042	Blower Speed Terminal Block	X	X	X	X	X	X	X	X	X
17	8620-223	Defrost Logic Control Board w/Sensor	X	X	X	X	X	X	X	X	X
18	8407-068	Transformer	X	X		X	X		X	X	
18	8407-069	Transformer			X			X			X
19	8201-126	Phase Monitor		X	X		X	X		X	X
20	8552-079	Compressor Capacitor	X			X			X		
20	8552-089	Compressor Capacitor		X			X			X	
20	8552-005	Outdoor Motor Capacitor			X			X			X
20	8552-004	Outdoor Motor Capacitor						X			X
21	8550-008	Capacitor Strap	X			X			X		
21	8550-003	Capacitor Strap		X	X		X	X		X	X
23	8401-034	Compressor Contactor	X			X			X		
23	8401-035	Compressor Contactor		X	X		X	X		X	X
NS	8615-039	Circuit Breaker 45A 2 Pole ①	0			0			0		
NS	8615-040	Circuit Breaker 50A 2 Pole ①		0			0			0	
NS	8615-041	Circuit Breaker 60A 2 Pole ①							0		
NS	8615-042	Circuit Breaker 35A 3 Pole ①		0			0			0	
NS	8615-043	Circuit Breaker 40A 3 Pole ①								0	
NS	S8615-067	Toggle Disconnect			0			0			0
NS	4096-168	Wiring Diagram	X			X			X		
NS	4096-169	Wiring Diagram		X			X			X	
NS	4096-270	Wiring Diagram									X
NS	4096-271	Wiring Diagram			X			X			X
NS	4096-368	Wiring Diagram						X			X
NS	4096-369	Wiring Diagram			X						X
NS	3000-1613	Blower Power Plug	X	X	X	X	X	X	X	X	X
NS	3000-1614	Blower Speed Plug	X	X	X	X	X	X	X	X	X
NS	3000-1222	Compressor Plug/Harness	X			X			X		
NS	3000-1230	Compressor Plug/Harness		X	X		X	X		X	X
NS	3003-064	Control Panel Wire Harness	X			X			X		
NS	3003-065	Control Panel Wire Harness		X			X			X	
NS	3003-066	Control Panel Wire Harness			X			X			X
NS	3000-1608	Low Voltage Terminal Block Wire Harness	X	X	X	X	X	X	X	X	X
NS	8201-032	Outdoor Fan Relay (located where start device shown)			X			X			X

NS = Not Shown

① Circuit breakers listed are for units without electric heat, "OZ" models. See heater replacement parts manual for units with electric heat.

X – Standard Component

O – Optional Component

BLOWER ASSEMBLY

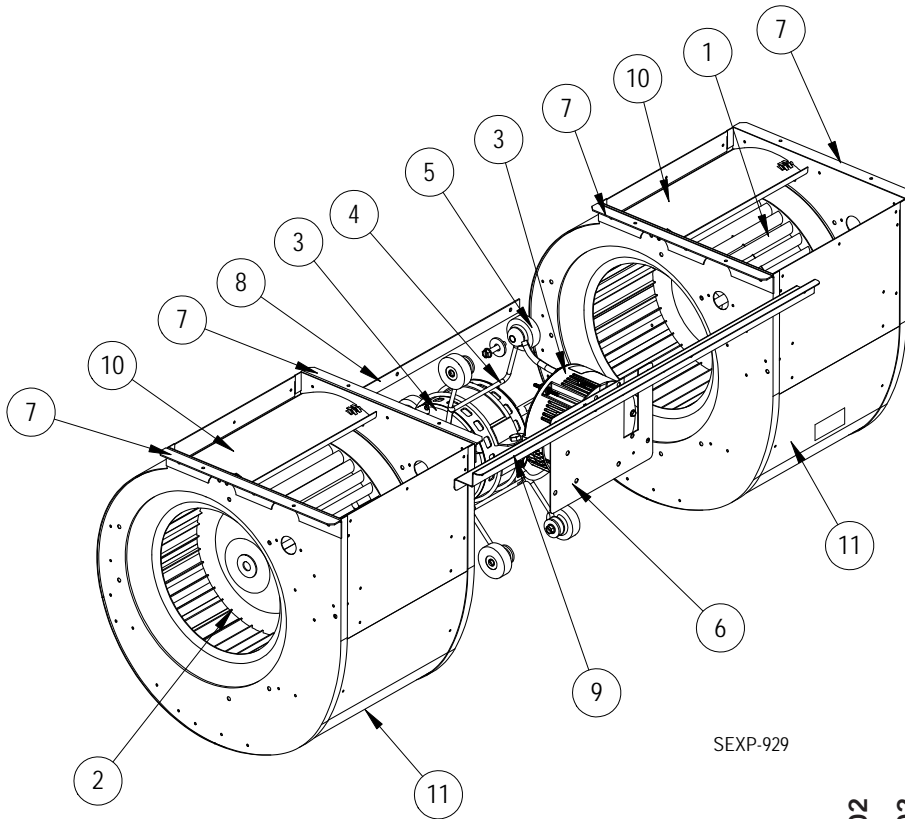

SEXP-929

Dwg No.	Part Number	Description	S900-366-002	S900-367-002	S900-368-004	S900-368-005	S900-369-004	S900-369-005
1	5152-011	10 Inch Wheel (CW)	X	X	X	X	X	X
2	5152-012	10 Inch Wheel (CW)	X	X	X	X	X	X
3	S8106-068-0185	Programmed Blower Motor & Control (230/208V)	X					
3	S8106-069-0176	Programmed Blower Motor & Control (460V)		X				
3	S8107-028-0177	Programmed Blower Motor & Control (230/208V)			X			
3	S8107-028-0179	Programmed Blower Motor & Control (230/208V)				X		
3	S8107-029-0178	Programmed Blower Motor & Control (460V)					X	
3	S8107-029-0180	Programmed Blower Motor & Control (460V)						X
3	C8106-074-0185	Programmed Control Only (230/208V)	0					
3	C8106-075-0176	Programmed Control Only (460V)		0				
3	C8107-030-0177	Programmed Control Only (230/208V)			0			
3	C8107-030-0179	Programmed Control Only (230/208V)				0		
3	C8107-031-0178	Programmed Control Only (460V)					0	
3	C8107-031-0180	Programmed Control Only (460V)						0
4	8200-040	Motor Mount	X	X	X	X	X	X
5	5451-011	Grommets	6	6	6	6	6	6
6	112-775	Motor Control Bracket	X	X	X	X	X	X
7	105-880	Side Angle	4	4	4	4	4	4
8	105-881	Back Brace	X	X	X	X	X	X
9	103-541	Front Mounting Offset	X	X	X	X	X	X
10	144-166	Diffuser	2	2	2	2	2	2
11	151-101	Blower Housing	2	2	2	2	2	2