

# REPLACEMENT PARTS MANUAL

## 11EER Q-TEC™ Series

Models:

	Q36A4DA	Q42A4DA	Q48A4DA	
	Q36A4DB	Q42A4DB	Q48A4DB	
	Q36A4DC	Q42A4DC	Q48A4DC	
Q24H4-A	Q30H4-A	Q36H4-A	Q43H4-A	Q48H4-A
Q24H4-B	Q30H4-B	Q36H4-B	Q43H4-B	Q48H4-B
Q24H4-C	Q30H4-C	Q36H4-C	Q43H4-C	Q48H4-C
Q24H4DA	Q30H4DA	Q36H4DA	Q43H4DA	Q48H4DA
Q24H4DB	Q30H4DB	Q36H4DB	Q43H4DB	Q48H4DB
Q24H4DC	Q30H4DC	Q36H4DC	Q43H4DC	Q48H4DC

## Contents

Description	Page	Description	Page
External Components – Standard & Dehum.		Blower Assembly Components – Q24/30*4	
♦ Exploded View .....	2	♦ Exploded View and Usage List .....	16
♦ Usage List .....	3	Blower Assembly Components – Q36/42/43/48*4	
Internal Components – Standard & Dehum.		♦ Exploded View and Usage List .....	17
♦ Exploded View .....	4	<b>General Notes</b>	
♦ Usage List .....	5	➤ Revised and/or additional pages may be issued from time to time.	
Functional Components – Standard & Dehum.		➤ A complete and current manual consists of pages shown in the following contents section.	
♦ Exploded View .....	6	<b>Important</b>	
♦ Usage List .....	7	➤ Contact the installing and/or local Bard distributor for all parts requirements. Make sure to have the complete model and serial number available from the unit rating plates.	
♦ Usage List .....	8		
♦ Usage List .....	9		
Control Panel Components – QA Dehumidification			
♦ Layout View .....	10		
♦ Usage List .....	11		
Control Panel Components – QH Standard & Dehum.			
♦ Layout View .....	12		
♦ Usage List .....	13		
♦ Usage List .....	14		



Bard Manufacturing Company, Inc.  
 Bryan, Ohio 43506  
 www.bardhvac.com

Manual: 2110-1568F  
 Supersedes: 2110-1568E  
 Date: 6-28-21

# EXTERNAL COMPONENTS - STANDARD & DEHUMIDIFICATION

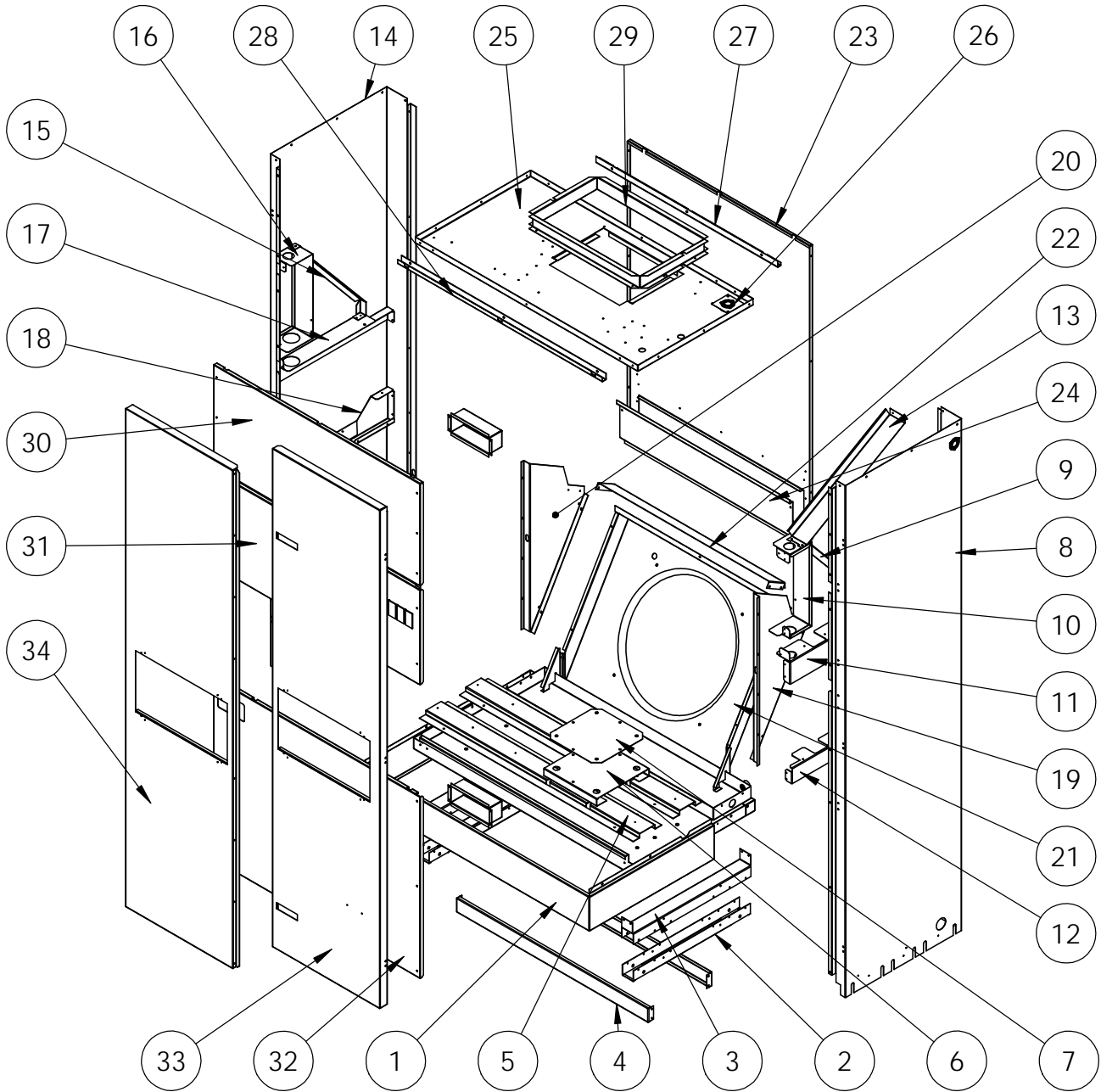

SEXP-1022

## EXTERNAL COMPONENTS – STANDARD & DEHUMIDIFICATION

Dwg No.	Part Number	Description	Q24H4-A, B, C Q24H4DA, B, C	Q30H4-A, B, C Q30H4DA, B, C	Q36H4-A, B, C	Q36A4DA, B, C Q36H4DA, B, C	Q42A4DA, B, C	Q43H4-A, B, C	Q43H4DA, B, C	Q48H4-A, B, C	Q48A4DA, B, C Q48H4DA, B, C
1	135-401-6	Base Trim	X	X	X	X					
1	135-402-6	Base Trim						X	X	X	X
2	141-510	Lower Wheel Rail	2	2	2	2	2	2	2	2	2
3	141-509	Upper Wheel Rail	2	2	2	2	2	2	2	2	2
4	135-399	Base Supports/Seal Angles	2	2	2	2					
4	135-403	Base Supports/Seal Angles					2	2	2	2	2
5	527-588-X	Base Assembly	X	X	X	X					
5	527-595-X	Base Assembly					X	X	X	X	X
6	141-368	Compressor Support	X	X	X	X	X	X	X	X	X
7	140-369	Compressor Support Plate	X	X	X	X	X	X	X	X	X
8	501-1088-*	Right Side	X	X	X	X	X	X	X	X	X
9	146-057	Right Evaporator Support Angle	X	X	X	X	X	X	X	X	X
10	105-1486	Right Control Panel Mounting Bracket	X	X	X	X	X	X	X	X	X
11	105-1502	Right Filter Partition Mounting Angle	X	X	X	X	X	X	X	X	X
12	105-1483	Right Condenser Partition Angle	X	X	X	X	X	X	X	X	X
13	135-400	Field Wire Channel	X	X	X	X	X	X	X	X	X
14	501-1089-*	Left Side	X	X	X	X					
14	501-1095-*	Left Side					X	X	X	X	X
15	146-058	Left Evaporator Support Angle	X	X	X	X	X	X	X	X	X
16	105-1487	Left Control Panel Mounting Bracket	X	X	X	X	X	X	X	X	X
17	105-1503	Left Filter Partition Mounting Angle	X	X	X	X	X	X	X	X	X
18	105-1484	Left Condenser Partition Angle	X	X	X	X	X	X	X	X	X
19	125Y098	Condenser Right Side	X	X	X	X	X	X	X	X	X
20	125X098	Condenser Left Side	X	X	X	X	X	X	X	X	X
21	125-101	Fan Shroud	X	X	X	X					
21	125-103	Fan Shroud					X	X	X	X	X
22	125-100	Condenser Top Fill	X	X	X	X					
22	125-102	Condenser Top Fill					X	X	X	X	X
23	509-430	Back	X	X	X	X					
23	509-438	Back					X	X	X	X	X
24	542-054	Fresh Air Intake Blank Off Plate	0	0	0	0	0	0	0	0	0
25	107-393	Top	X	X	X	X					
25	107-396	Top					X	X	X	X	X
26	136-359	T.K.O. Plate	X	X	X	X	X	X	X	X	X
27	105-1481	Upper Rear Captivation Plate	X	X	X	X					
27	105-1509	Upper Rear Captivation Plate					X	X	X	X	X
28	105-1482	Upper Front Captivation Plate	X	X	X	X					
28	105-1510	Upper Front Captivation Plate					X	X	X	X	X
29	111-329	Duct Flange	2	2	2	2	2	2	2	2	2
30	553-727	Blower Access Panel Assembly	X	X	X	X					
30	553-737	Blower Access Panel Assembly					X	X	X	X	X
31	533-317	Control Panel Cover Assembly	X	X	X	X					
31	533-322	Control Panel Cover Assembly					X	X	X	X	X
32	553-728	Condenser Access Panel Assembly	X	X	X	X					
32	553-736	Condenser Access Panel Assembly					X	X	X	X	X
33	553-725-*	Right Door Assembly	X	X	X	X					
33	553-734-*	Right Door Assembly					X	X	X	X	X
34	553-726-*	Left Door Assembly	X	X	X	X					
34	553-735-*	Left Door Assembly					X	X	X	X	X
NS	133-336	Condenser Fill Plate	X	X	X	X					
NS	133-337	Condenser Fill Plate					X	X	X	X	X

\* Exterior cabinet parts are manufactured with various paint color options. To ensure the proper paint color is received, include the complete model and serial number of the unit for which cabinet parts are being ordered.

X – Standard Component  
O – Optional Component

# INTERNAL COMPONENTS – STANDARD & DEHUMIDIFICATION

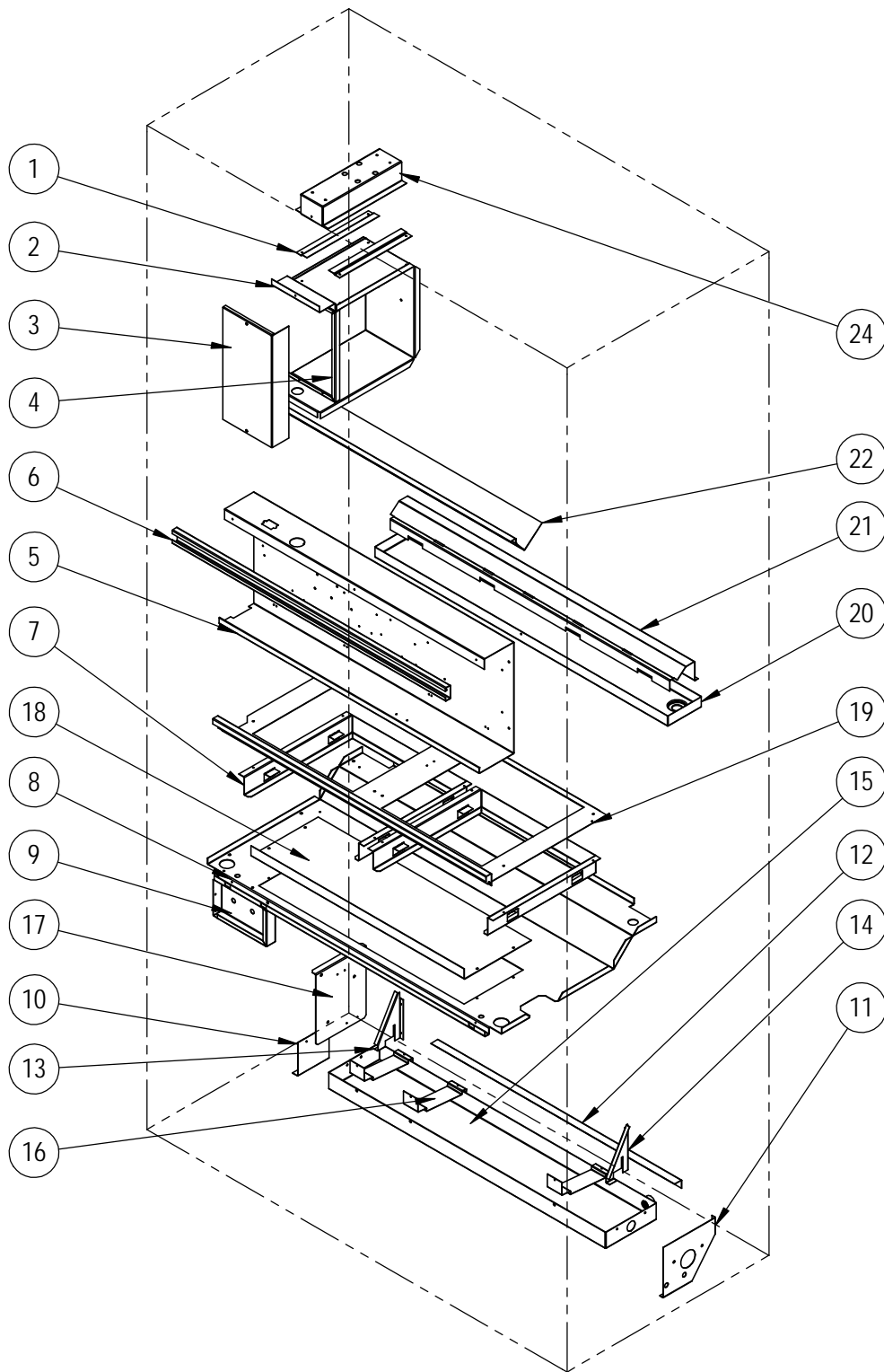

SEXP-1025

# INTERNAL COMPONENTS – STANDARD & DEHUMIDIFICATION

Dwg No.	Part Number	Description	Q24H4-A, B, C Q24H4DA, B, C	Q30H4-A, B, C Q30H4DA, B, C	Q36H4-A, B, C	Q36A4DA, B, C	Q36H4DA, B, C	Q42A4DA, B, C	Q43H4-A, B, C	Q43H4DA, B, C	Q48H4-A, B, C	Q48A4DA, B, C	Q48H4DA, B, C
1	103-417	Heater Package Offsets	2	2	2	2	2	2	2	2	2	2	2
2	117-191	Heat Strip Mounting Bracket	X	X	X	X	X	X	X	X	X	X	X
3	133-321	Heater Package Cover	X	X	X	X	X	X	X	X	X	X	X
4	105-987	Heat Strip Angle	X	X	X	X	X	X	X	X	X	X	X
5	117-422	Control Panel	X	X	X	X	X	X					
5	117-429	Control Panel							X	X	X	X	X
6	165-618	Front "C" Channel	X	X	X	X	X	X					
6	165-619	Front "C" Channel							X	X	X	X	X
7	131-172	Filter Angle - 16"	2	2	2	2	2	2	X	X	X	X	X
7	131-176	Filter Angle - 20"							X	X	X	X	X
8	121-604	Condenser Partition	X	X	X	X	X	X					
8	121-611	Condenser Partition							X	X	X	X	X
9	113-824	Service Port Mounting Bracket	X	X	X	X	X	X	X	X	X	X	X
10	141-230	Left Condenser Drain Pan Bracket	X	X	X	X	X	X	X	X	X	X	X
11	141-511	Right Condenser Drain Pan Bracket	X	X	X	X	X	X	X	X	X	X	X
12	143-237	Condenser Pan Fill Angle	X	X	X	X	X	X					
12	143-240	Condenser Pan Fill Angle							X	X	X	X	X
13	131Y173	Left Condenser Fill Pan Angle	X	X	X	X	X	X	X	X	X	X	X
14	131X173	Right Condenser Fill Pan Angle	X	X	X	X	X	X	X	X	X	X	X
15	123-164	Condenser Drain Pan	X	X	X	X	X	X					
15	123-165	Condenser Drain Pan							X	X	X	X	X
16	140-513	Copper Hold Down Bracket	2	2	2		2		2	2	2		2
17	113-834	Fan Motor Control Bracket	X	X	X	X	X	X	X	X	X	X	X
18	536-351*	Exhaust Blank Off Plate	0	0	0	0	0	0	0	0	0	0	0
19	131-171	Filter Partition	X	X	X	X	X	X					
19	131-175	Filter Partition							X	X	X	X	X
20	123-163	Evaporator Drain Pan	X	X	X	X	X	X					
20	123-166	Evaporator Drain Pan							X	X	X	X	X
21	105-1476	Evaporator Coil Riser	X	X	X	X	X	X					
21	105-1508	Evaporator Coil Riser							X	X	X	X	X
22	143-235	Evaporator Top Coil Fill			X	X	X	X					
22	143-236	Evaporator Top Coil Fill	X	X									
22	143-238	Evaporator Top Coil Fill							X	X	X	X	X
24	113-850	Heater Package Mounting Bracket	X	X	X	X	X	X	X	X	X	X	X

\* Unit may have alternative vent installed. Please see vent manual for part information.

X – Standard Component  
O – Optional Component

# FUNCTIONAL COMPONENTS – STANDARD & DEHUMIDIFICATION

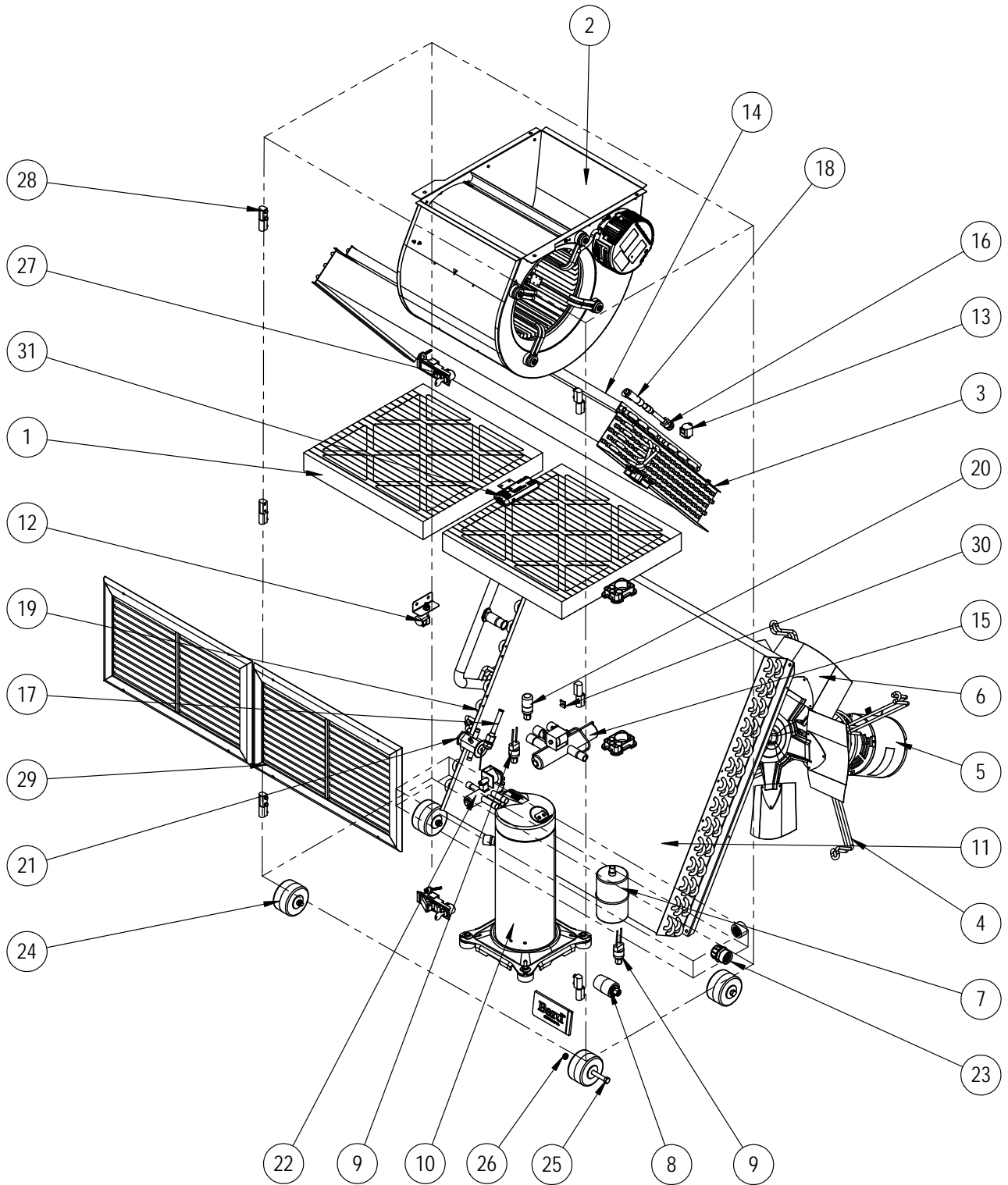

SEXP-1023

## FUNCTIONAL COMPONENTS – QA DEHUMIDIFICATION

Dwg No.	Part Number	Description	Q36A4DA	Q36A4DB	Q36A4DC	Q42A4DA	Q42A4DB	Q42A4DC	Q48A4DA	Q48A4DB	Q48A4DC
1	7004-009	Air Filter 1" Throw-Away (16 x 16 x 1)	2	2	2	2	2	2	1	1	1
1	7004-010	Air Filter 1" Throw-Away (16 x 20 x 1)							1	1	1
1	7003-032 ①	Air Filter 2" MERV 4 (16 x 16 x 2)	2	2	2	2	2	2	1	1	1
1	7003-033 ①	Air Filter 2" MERV 4 (16 x 20 x 2)							1	1	1
1	7004-034 ①	Air Filter 2" MERV 8 (16 x 16 x 2)	2	2	2	2	2	2	1	1	1
1	7004-035 ①	Air Filter 2" MERV 8 (16 x 20 x 2)							1	1	1
1	7004-069 ①	Air Filter 2" MERV 13 (16 x 16 x 2)	2	2	2	2	2	2	1	1	1
1	7004-070 ①	Air Filter 2" MERV 13 (16 x 20 x 2)							1	1	1
2	5154-005-0228	Blower Assembly (see page 17)				X	X	X			
2	5154-005-0210	Blower Assembly (see page 17)	X	X	X						
2	5154-007-0216	Blower Assembly (see page 17)							X	X	X
3	917-0439BX	Indoor & Reheat Coil w/Distributor Assembly	X	X	X	X	X	X			
3	917-0440BX	Indoor & Reheat Coil - Coated w/Distributor Assembly	0	0	0	0	0	0			
3	917-0450BX	Indoor & Reheat Coil w/Distributor Assembly							X	X	X
3	917-0451BX	Indoor & Reheat Coil - Coated w/Distributor Assembly							0	0	0
4	8200-001	Fan Motor Mount	X	X	X	X	X	X	X	X	X
5	8106-047-0223	Condenser Motor	X	X	X	X	X	X	X	X	X
6	5151-055	Fan Blade	X	X	X	X	X	X	X	X	X
7	5201-021	Filter Drier	X	X	X	X	X	X			
7	5201-022	Filter Drier							X	X	X
8	S8406-112	Low Ambient Control (LAC)	0	0	0	0	0	0	0	0	0
9	8406-142	High Pressure Switch	X	X	X	X	X	X	X	X	X
9	8406-140	Low Pressure Switch	X	X	X	X	X	X	X	X	X
10	8000-463	Compressor ZP31K6E-PFV-130	X								
10	8000-464	Compressor ZP31K6E-TF5-130		X							
10	8000-465	Compressor ZP31K6E-TFD-130			X						
10	8000-478	Compressor ZP36K6E-PFV-130				X					
10	8000-479	Compressor ZP36K6E-TF5-130					X				
10	8000-480	Compressor ZP36K6E-TFD-130						X			
10	8000-481	Compressor ZP42K6E-PFV-130							X		
10	8000-482	Compressor ZP42K6E-TF5-130								X	
10	8000-483	Compressor ZP42K6E-TFD-130									X
11	917-0455BX	Outdoor Coil (Includes Distributor)	X	X	X	X	X	X			
11	917-0456BX	Outdoor Coil - Coated (Includes Distributor)	0	0	0	0	0	0			
11	917-0458BX	Outdoor Coil (Includes Distributor)							X	X	X
11	917-0459BX	Outdoor Coil - Coated (Includes Distributor)							0	0	0
NS	5051-161	Outdoor Coil - 8 X 36							X	X	X
13	8408-048	Freeze Protection Thermostat	0	0	0	0	0	0	0	0	0
14	5051-102BX	Reheat Coil	X	X	X	X	X	X			
14	5054-102BX	Reheat Coil - Coated	0	0	0	0	0	0			
14	5051-242BX	Reheat Coil							X	X	X
14	5054-242BX	Reheat Coil - Coated							0	0	0
16	800-0417	Distributor Assembly - Indoor Coil	X	X	X	X	X	X	X	X	X
18	5651S245	Electronic Expansion Valve	X	X	X	X	X	X	X	X	X
18	905-0771	Electronic Expansion Valve (EEV) Assembly	X	X	X	X	X	X	X	X	X
20	8406-158	Low Pressure Transducer	X	X	X	X	X	X	X	X	X
22	5650-051	Dehumidification Valve	X	X	X	X	X	X	X	X	X
23	6094-003	Drain Fitting	X	X	X	X	X	X	X	X	X
24	1171-035	Wheel	4	4	4	4	4	4	4	4	4
25	1012-129	Bolt - Shoulder	4	4	4	4	4	4	4	4	4
26	1012-224	Nut - Locking	4	4	4	4	4	4	2	2	2
27	1171-063	Door Latch	2	2	2	2	2	2	2	2	2
28	5400-005	Door Hinge Assembly	6	6	6	6	6	6	6	6	6
29	7051-095	Return Air Louvers	2	2	2	2	2	2	2	2	2
30	1171-070	"U" Clip Fastener	18	18	18	18	18	18	18	18	18
31	8602-058	Mixed Air Sensor	0	0	0	0	0	0	0	0	0
NS	5651-219	Check Valve	2	2	2	2	2	2	2	2	2
NS	5451-024	Tubing Insulation Grommet	3	3	3	3	3	3	3	3	3
NS	6031-009	Coremax Valve Core	2	2	2	2	2	2	2	2	2
NS	8407-003	Stepdown Transformer 1.5Kva - with ERV			X			X			X
NS	8407-058	Stepdown Transformer 1 Kva			X			X			X

NS – Not Shown  
 ① – Optional on these models

X – Standard Component  
 0 – Optional Component

# FUNCTIONAL COMPONENTS – OH STANDARD & DEHUMIDIFICATION

Dwg No.	Part Number	Description	Q24H4-A	Q24H4-B	Q24H4-C	Q24H4DA	Q24H4DB	Q24H4DC	Q30H4-A	Q30H4-B	Q30H4-C	Q30H4DA	Q30H4DB	Q30H4DC	Q36H4-A	Q36H4-B	Q36H4-C	Q36H4DA	Q36H4DB	Q36H4DC
1	7004-009	Air Filter 1" Throw-Away (16 x 16 x 1)	2	2	2	2	2	2	2	2	2	2	2	2	2	2	2	2	2	2
1	7003-032 ①	Air Filter 2" MERV 4 (16 x 16 x 2)	2	2	2	2	2	2	2	2	2	2	2	2	2	2	2	2	2	2
1	7004-034 ①	Air Filter 2" MERV 8 (16 x 16 x 2)	2	2	2	2	2	2	2	2	2	2	2	2	2	2	2	2	2	2
1	7004-069 ①	Air Filter 2" MERV 13 (16 x 16 x 2)	2	2	2	2	2	2	2	2	2	2	2	2	2	2	2	2	2	2
2	5154-002-0212	Blower Assembly (see page 16)	X	X	X	X	X	X												
2	5154-002-0211	Blower Assembly (see page 16)							X	X	X	X	X	X						
2	5154-005-0210	Blower Assembly (see page 17)													X	X	X	X	X	X
3	917-0433BX	Indoor Coil w/Distributor Assembly	X	X	X															
3	917-0434BX	Indoor Coil - Coated w/Distributor Assembly	O	O	O															
3	917-0436BX	Indoor Coil w/Distributor Assembly				X	X	X				X	X	X						
3	917-0437BX	Indoor Coil - Coated w/Distributor Assembly				O	O	O				O	O	O						
3	917-0428BX	Indoor Coil w/Distributor Assembly							X	X	X									
3	917-0429BX	Indoor Coil - Coated w/Distributor Assembly							O	O	O									
3	917-0424BX	Indoor Coil w/Distributor Assembly													X	X	X			
3	917-0425BX	Indoor Coil - Coated w/Distributor Assembly													O	O	O			
3	917-0439BX	Indoor & Reheat Coil w/Distributor Assembly																X	X	X
3	917-0440BX	Indoor & Reheat Coil - Coated w/Distributor Assembly																O	O	O
4	8200-001	Fan Motor Mount	X	X	X	X	X	X	X	X	X	X	X	X	X	X	X	X	X	X
5	8106-047-0213	Condenser Motor	X	X	X	X	X	X	X	X	X	X	X	X	X	X	X	X	X	X
6	5151-055	Fan Blade	X	X	X	X	X	X	X	X	X	X	X	X	X	X	X	X	X	X
7	5201-010	Filter Drier	X	X	X	X	X	X	X	X	X	X	X	X	X	X	X	X	X	X
8	S8406-112	Low Ambient Control (LAC)	O	O	O	O	O	O	O	O	O	O	O	O	O	O	O	O	O	O
9	8406-142	High Pressure Switch	X	X	X	X	X	X	X	X	X	X	X	X	X	X	X	X	X	X
9	8406-135	Low Pressure Switch	X	X	X	X	X	X	X	X	X	X	X	X	X	X	X	X	X	X
10	8000-276	Compressor ZP20K5E-PFV-130	X			X														
10	8000-367	Compressor ZP20K5E-TF5-130		X			X													
10	8000-368	Compressor ZP20K5E-TFD-130			X			X												
10	8000-468	Compressor ZP25K6E-PFV-130						X				X								
10	8000-469	Compressor ZP25K6E-TF5-130							X				X							
10	8000-470	Compressor ZP25K6E-TFD-130								X			X							
10	8000-463	Compressor ZP31K6E-PFV-130												X			X			
10	8000-464	Compressor ZP31K6E-TF5-130													X		X			
10	8000-465	Compressor ZP31K6E-TFD-130														X	X			X
11	917-0430BX	Outdoor Coil (Includes Distributor)	X	X	X	X	X	X	X	X	X	X	X	X						
11	917-0431BX	Outdoor Coil - Coated (Includes Distributor)	O	O	O	O	O	O	O	O	O	O	O	O						
11	917-0426BX	Outdoor Coil (Includes Distributor)													X	X	X	X	X	X
11	917-0427BX	Outdoor Coil - Coated (Includes Distributor)													O	O	O	O	O	O
12	8408-060	Outdoor Temperature Sensor	O	O	O	O	O	O	O	O	O	O	O	O	O	O	O	O	O	O
13	8408-048	Freeze Protection Thermostat	O	O	O	O	O	O	O	O	O	O	O	O	O	O	O	O	O	O
14	5051-241BX	Reheat Coil				X	X	X				X	X	X				X	X	X
14	5054-241BX	Reheat Coil - Coated				O	O	O				O	O	O				O	O	O
15	5650-039	Reversing Valve	X	X	X	X	X	X	X	X	X	X	X	X	X	X	X	X	X	X
16	800-0459	Distributor Assembly - Indoor Coil	X	X	X															
16	800-0421	Distributor Assembly - Indoor Coil				X	X	X				X	X	X						
16	800-0499	Distributor Assembly - Indoor Coil							X	X	X									
16	800-0494	Distributor Assembly - Indoor Coil													X	X	X			
16	800-0417	Distributor Assembly - Indoor Coil																X	X	X
17	800-0497	Distributor Assembly - Outdoor Coil													X	X	X	X	X	X
17	800-0498	Distributor Assembly - Outdoor Coil	X	X	X	X	X	X	X	X	X	X	X	X						
18	5651S245	Electronic Expansion Valve				X	X	X				X	X	X				X	X	X
18	905-0771	Electronic Expansion Valve (EEV) Assembly				X	X	X				X	X	X				X	X	X
19	8408-045	Defrost Thermistor	X	X	X	X	X	X	X	X	X	X	X	X	X	X	X	X	X	X
20	8406-158	Low Pressure Transducer				X	X	X				X	X	X				X	X	X
21	5651-178	Heating Expansion Valve	X	X	X				X	X	X				X	X	X			
22	5650-051	Dehumidification Valve				X	X	X				X	X	X				X	X	X
23	6094-003	Drain Fitting	X	X	X	X	X	X	X	X	X	X	X	X	X	X	X	X	X	X
24	1171-035	Wheel	4	4	4	4	4	4	4	4	4	4	4	4	4	4	4	4	4	4
25	1012-129	Bolt - Shoulder	4	4	4	4	4	4	4	4	4	4	4	4	4	4	4	4	4	4
26	1012-224	Nut - Locking	4	4	4	4	4	4	4	4	4	4	4	4	4	4	4	4	4	4
27	1171-063	Door Latch	2	2	2	2	2	2	2	2	2	2	2	2	2	2	2	2	2	2
28	5400-005	Door Hinge Assembly	6	6	6	6	6	6	6	6	6	6	6	6	6	6	6	6	6	6
29	7051-095	Return Air Louvers	2	2	2	2	2	2	2	2	2	2	2	2	2	2	2	2	2	2
30	1171-070	"U" Clip Fastener	18	18	18	18	18	18	18	18	18	18	18	18	18	18	18	18	18	18
31	8602-058	Mixed Air Sensor	O	O	O	O	O	O	O	O	O	O	O	O	O	O	O	O	O	O
NS	5651-219	Check Valve				2	2	2				2	2	2				2	2	2
NS	5451-024	Tubing Insulation Grommet	3	3	3	3	3	3	3	3	3	3	3	3	3	3	3	3	3	3
NS	6031-009	Coremax Valve Core	2	2	2	2	2	2	2	2	2	2	2	2	2	2	2	2	2	2
NS	8407-003	Stepdown Transformer 1.5Kva - with ERV			X			X			X			X			X			X
NS	8407-058	Stepdown Transformer 1 Kva			X			X			X			X			X			X

NS – Not Shown

① – Optional on these models

X – Standard Component

O – Optional Component



# FUNCTIONAL COMPONENTS – QH STANDARD & DEHUMIDIFICATION

Dwg No.	Part Number	Description	Q43H4-A	Q43H4-B	Q43H4-C	Q43H4DA	Q43H4DB	Q43H4DC	Q48H4-A	Q48H4-B	Q48H4-C	Q48H4DA	Q48H4DB	Q48H4DC
1	7004-009	Air Filter 1" Throw-Away (16 x 16 x 1)	1	1	1	1	1	1	1	1	1	1	1	1
1	7004-010	Air Filter 1" Throw-Away (16 x 20 x 1)	1	1	1	1	1	1	1	1	1	1	1	1
1	7003-032 ①	Air Filter 2" MERV 4 (16 x 16 x 2)	1	1	1	1	1	1	1	1	1	1	1	1
1	7003-033 ①	Air Filter 2" MERV 4 (16 x 20 x 2)	1	1	1	1	1	1	1	1	1	1	1	1
1	7004-034 ①	Air Filter 2" MERV 8 (16 x 16 x 2)	1	1	1	1	1	1	1	1	1	1	1	1
1	7004-035 ①	Air Filter 2" MERV 8 (16 x 20 x 2)	1	1	1	1	1	1	1	1	1	1	1	1
1	7004-069 ①	Air Filter 2" MERV 13 (16 x 16 x 2)	1	1	1	1	1	1	1	1	1	1	1	1
1	7004-070 ①	Air Filter 2" MERV 13 (16 x 20 x 2)	1	1	1	1	1	1	1	1	1	1	1	1
2	5154-005-0215	Blower Assembly (see page 17)	X	X	X	X	X	X						
2	5154-007-0216	Blower Assembly (see page 17)	X	X	X	X	X	X	X	X	X	X	X	X
3	917-0445BX	Indoor Coil w/Distributor Assembly	X	X	X									
3	917-0446BX	Indoor Coil - Coated w/Distributor Assembly	O	O	O									
3	917-0447BX	Indoor Coil w/Distributor Assembly						X	X	X				
3	917-0448BX	Indoor Coil - Coated w/Distributor Assembly						O	O	O				
3	917-0450BX	Indoor and Reheat Coil w/Distributor Assembly				X	X	X				X	X	X
3	917-0451BX	Indoor and Reheat Coil - Coated w/Distributor Assembly				O	O	O				O	O	O
4	8200-001	Fan Motor Mount	X	X	X	X	X	X	X	X	X	X	X	X
5	8106-047-0223	Condenser Motor	X	X	X	X	X	X	X	X	X	X	X	X
6	5151-055	Fan Blade	X	X	X	X	X	X	X	X	X	X	X	X
7	5201-010	Filter Drier	X	X	X	X	X	X	X	X	X	X	X	X
8	S8406-112	Low Ambient Control (LAC)	O	O	O	O	O	O	O	O	O	O	O	O
9	8406-142	High Pressure Switch	X	X	X	X	X	X	X	X	X	X	X	X
9	8406-135	Low Pressure Switch	X	X	X	X	X	X	X	X	X	X	X	X
10	8000-478	Compressor ZP36K6E-PFV-130	X			X								
10	8000-479	Compressor ZP36K6E-TF5-130		X			X							
10	8000-480	Compressor ZP36K6E-TFD-130			X			X						
10	8000-481	Compressor ZP42K6E-PFV-130							X					
10	8000-482	Compressor ZP42K6E-TF5-130								X				
10	8000-483	Compressor ZP42K6E-TFD-130									X			X
11	917-0443BX	Outdoor Coil (Includes Distributor)	X	X	X	X	X	X	X	X	X	X	X	X
11	917-0444BX	Outdoor Coil - Coated (Includes Distributor)	O	O	O	O	O	O	O	O	O	O	O	O
NS	5051-161	Outdoor Coil - 8 X 36							X	X	X	X	X	X
12	8408-060	Outdoor Temperature Sensor	O	O	O	O	O	O	O	O	O	O	O	O
13	8408-048	Freeze Protection Thermostat	O	O	O	O	O	O	O	O	O	O	O	O
14	5051-242BX	Reheat Coil				X	X	X				X	X	X
14	5054-242BX	Reheat Coil - Coated				O	O	O				O	O	O
15	5650-040	Reversing Valve	X	X	X	X	X	X	X	X	X	X	X	X
16	800-0500	Distributor Assembly - Indoor Coil	X	X	X									
16	800-0447	Distributor Assembly - Indoor Coil							X	X	X			
16	800-0417	Distributor Assembly - Indoor Coil				X	X	X				X	X	X
17	800-0433	Distributor Assembly - Outdoor Coil	X	X	X	X	X	X	X	X	X	X	X	X
18	5651S245	Electronic Expansion Valve				X	X	X				X	X	X
18	905-0771	Electronic Expansion Valve (EEV) Assembly				X	X	X				X	X	X
19	8408-045	Defrost Thermistor	X	X	X	X	X	X	X	X	X	X	X	X
20	8406-158	Low Pressure Transducer				X	X	X				X	X	X
21	5651-184	Heating Expansion Valve	X	X	X				X	X	X			
22	5650-051	Dehumidification Valve				X	X	X				X	X	X
23	6094-003	Drain Fitting	X	X	X	X	X	X	X	X	X	X	X	X
24	1171-035	Wheel	4	4	4	4	4	4	4	4	4	4	4	4
25	1012-129	Bolt - Shoulder	4	4	4	4	4	4	4	4	4	4	4	4
26	1012-224	Nut - Locking	2	2	2	2	2	2	2	2	2	2	2	2
27	1171-063	Door Latch	2	2	2	2	2	2	2	2	2	2	2	2
28	5400-005	Door Hinge Assembly	6	6	6	6	6	6	6	6	6	6	6	6
29	7051-096	Return Air Louvers	2	2	2	2	2	2	2	2	2	2	2	2
30	1171-070	"U" Clip Fastener	18	18	18	18	18	18	18	18	18	18	18	18
31	8602-058	Mixed Air Sensor	O	O	O	O	O	O	O	O	O	O	O	O
NS	5651-219	Check Valve				2	2	2				2	2	2
NS	5451-024	Tubing Insulation Grommet	3	3	3	3	3	3	3	3	3	3	3	3
NS	6061-009	Coremax Valve Core	2	2	2	2	2	2	2	2	2	2	2	2
NS	8407-003	Stepdown Transformer 1.5Kva - with ERV			X			X			X			X
NS	8407-058	Stepdown Transformer 1 Kva			X			X			X			X

NS – Not Shown  
 ① – Optional on these models

X – Standard Component  
 O – Optional Component

# CONTROL PANEL COMPONENTS – QA DEHUMIDIFICATION

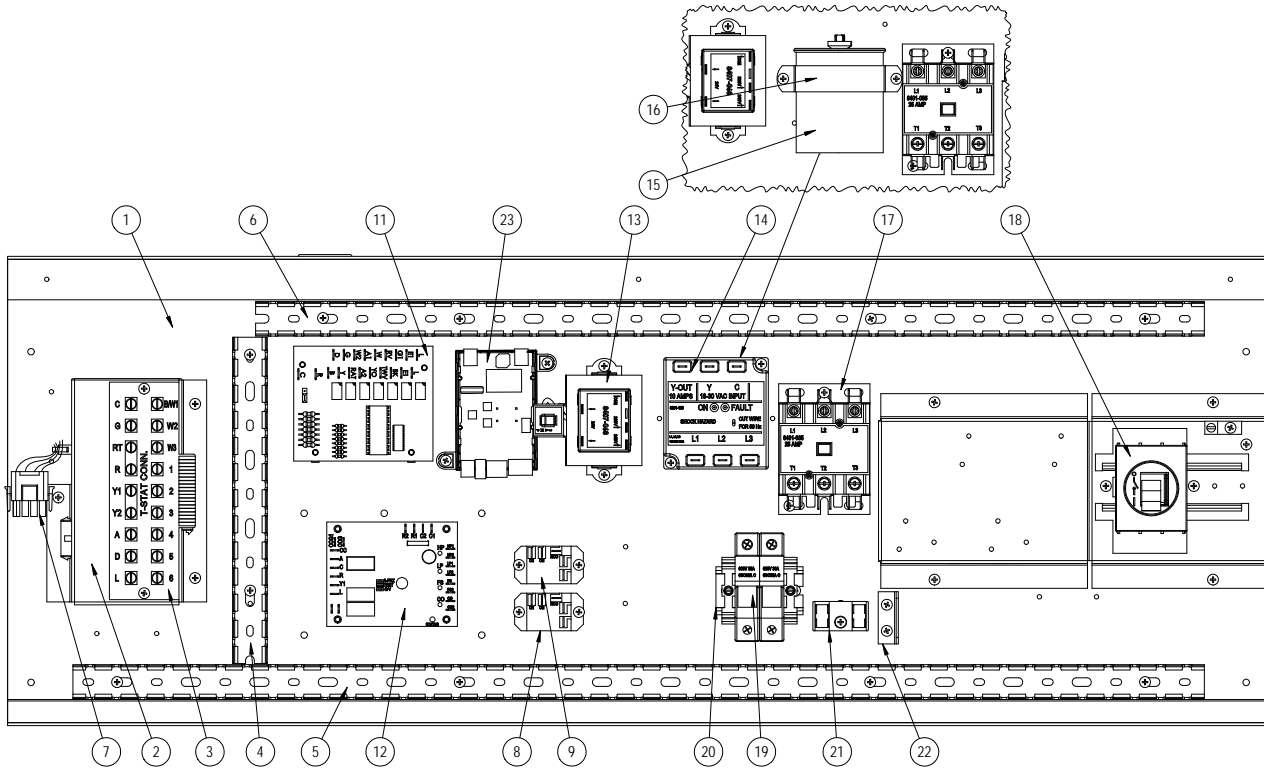

SEXP-1054

## CONTROL PANEL COMPONENTS - QA DEHUMIDIFICATION

Dwg No.	Part Number	Description	Q36A4DA	Q36A4DB	Q36A4DC	Q42A4DA	Q42A4DB	Q42A4DC	Q48A4DA	Q48A4DB	Q48A4DC
1	517-422	Control Panel (sheet metal only)	X	X	X	X	X	X			
1	517-429								X	X	X
2	117-424	Low Voltage Box	X	X	X	X	X	X	X	X	X
3	8607-063	Low Voltage Strip	X	X	X	X	X	X	X	X	X
4	8611-140-0903	Cable Duct - 9 3/16"	X	X	X	X	X	X	X	X	X
5	8611-140-3200	Cable Duct - 32"	X	X	X	X	X	X	X	X	X
6	8611-140-2704	Cable Duct - 27 1/4"	X	X	X	X	X	X	X	X	X
7	3000-1524	Vent Jumper Plug (used when no vent installed)	X	X	X	X	X	X	X	X	X
8	8201-130	EVD Control Relay	X	X	X	X	X	X	X	X	X
9	8201-130	Dehum Control Relay Relay	X	X	X	X	X	X	X	X	X
11	S8201-113	Dehumidification Logic Board	X	X	X	X	X	X	X	X	X
12	8201-140	Compressor Logic Board	X	X	X	X	X	X	X	X	X
13	8407-069	Transformer	X	X	X	X	X	X	X	X	X
14	S8201-126	Phase Monitor ①		X	X		X	X		X	X
15	8552-043	Compressor Capacitor	X			X					
15	8552-081	Compressor Capacitor							X		
16	8550-008	Capacitor Strap	X			X			X		
17	8401-034	Compressor Contactor	X			X			X		
17	8401-035	Compressor Contactor		X	X		X	X		X	X
18	8615-051	Circuit Breaker 25A 3 Pole ②		X			X				
18	8615-052	Circuit Breaker 30A 3 Pole ②								X	
18	8615-055	Circuit Breaker 40A 2 Pole ②	X			X			X		
18	S8615-095	Toggle Disconnect			X			X			X
19	8615-058	Fuse Block			X			X			X
20	8611-210	Din Rail 2-1/2"			X			X			X
21	8607-017	Terminal Block			X			X			X
22	141-188	Heater Plug Bracket	X	X	X	X	X	X	X	X	X
23	8301-079-0003	EVD Control Board (Programmed )	X	X	X	X	X	X	X	X	X
NS	3000-1145	Blower Power Plug	X	X	X	X	X	X	X	X	X
NS	3000-1337	Compressor Wire Harness	X			X			X		
NS	3000-1338	Compressor Wire Harness		X	X		X	X		X	X
NS	3003-094	Control Panel Wire Harness	X			X			X		
NS	3003-095	Control Panel Wire Harness		X			X			X	
NS	3003-096	Control Panel Wire Harness			X			X			X
NS	3003-1694	Upper Low Voltage Wire Harness	X	X	X	X	X	X	X	X	X
NS	8614-046	5A Class CC Fuse - with ERV installed ③			2			2			2
NS	8614-047	3.2A Class CC Fuse			2			2			2
NS	4107-106	Wiring Diagram	X			X			X		
NS	4107-206	Wiring Diagram		X			X			X	
NS	4107-306	Wiring Diagram			X			X			X

NS = Not Shown

X – Standard Component

① Only used for three phase units; single phase models use capacitors.

O – Optional Component

② Circuit breakers listed are for units without electric heat, "OZ" models. See heater replacement parts manual for units with electric heat.

③ Q\*\*A4DC models will have two (2) of the same fuse installed; part number is determined by the vent package installed.

# CONTROL PANEL COMPONENTS – QH STANDARD & DEHUMIDIFICATION

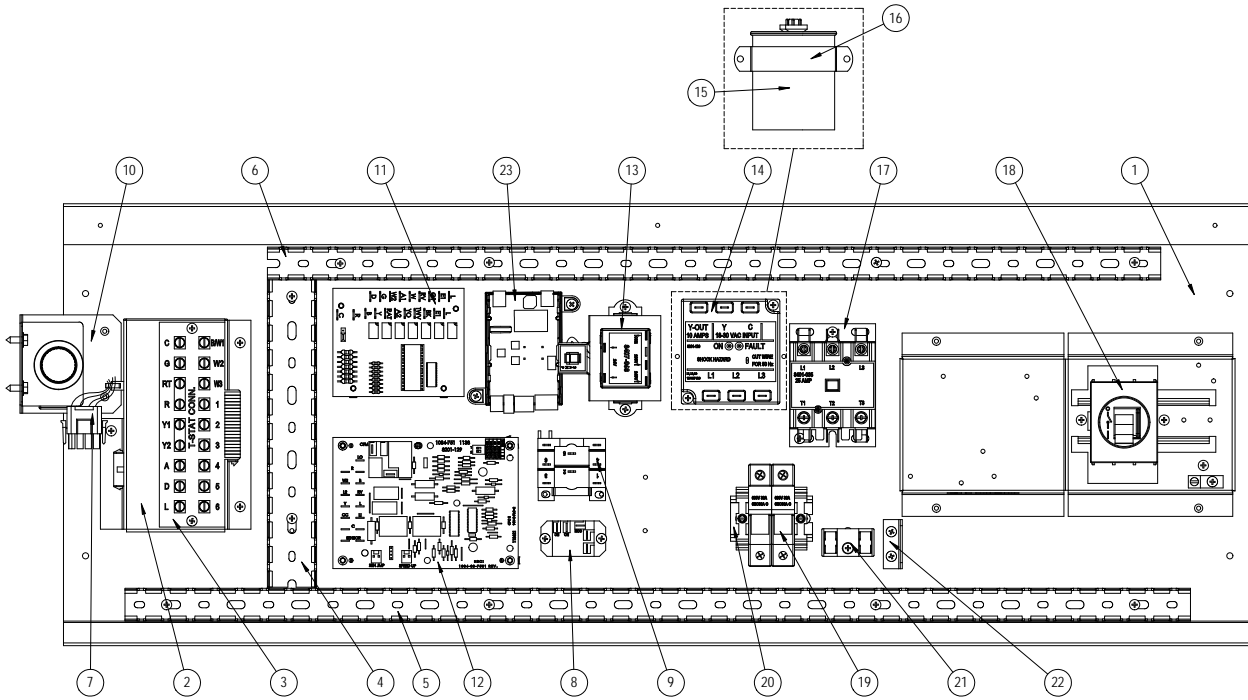

SEXP-1024

# CONTROL PANEL COMPONENTS – QH STANDARD & DEHUMIDIFICATION

Dwg No.	Part Number	Description	Q24H4-A	Q24H4-B	Q24H4-C	Q24H4DA	Q24H4DB	Q24H4DC	Q30H4-A	Q30H4-B	Q30H4-C	Q30H4DA	Q30H4DB	Q30H4DC	Q36H4-A	Q36H4-B	Q36H4-C	Q36H4DA	Q36H4DB	Q36H4DC
1	517-422	Control Panel (sheet metal only)	X	X	X	X	X	X	X	X	X	X	X	X	X	X	X	X	X	X
2	117-424	Low Voltage Box	X	X	X	X	X	X	X	X	X	X	X	X	X	X	X	X	X	X
3	8607-063	Low Voltage Strip	X	X	X	X	X	X	X	X	X	X	X	X	X	X	X	X	X	X
4	8611-140-0903	Cable Duct - 9 3/16"	X	X	X	X	X	X	X	X	X	X	X	X	X	X	X	X	X	X
5	8611-140-3200	Cable Duct - 32"	X	X	X	X	X	X	X	X	X	X	X	X	X	X	X	X	X	X
6	8611-140-2704	Cable Duct - 27 1/4"	X	X	X	X	X	X	X	X	X	X	X	X	X	X	X	X	X	X
7	3000-1524	Vent Jumper Plug (used when no vent installed)	X	X	X	X	X	X	X	X	X	X	X	X	X	X	X	X	X	X
8	8201-130	Blower Speed Relay	X	X	X	X	X	X	X	X	X	X	X	X	X	X	X	X	X	X
9	8201-086	OD T-Stat/LAC Relay	O	O	O	O	O	O	O	O	O	O	O	O	O	O	O	O	O	O
10	8408-028	Outdoor Thermostat	O	O	O	O	O	O	O	O	O	O	O	O	O	O	O	O	O	O
11	S8201-113	Dehumidification Logic Board				X	X	X				X	X	X				X	X	X
12	8620-223	Defrost Logic Control Board w/Sensor	X	X	X	X	X	X	X	X	X	X	X	X	X	X	X	X	X	X
13	8407-069	Transformer	X	X	X	X	X	X	X	X	X	X	X	X	X	X	X	X	X	X
14	S8201-126	Phase Monitor ①		X	X		X	X		X	X		X	X		X	X		X	X
15	8552-086	Compressor Capacitor	X			X			X			X								
15	8552-043	Compressor Capacitor												X				X		
16	8550-006	Capacitor Strap	X			X			X			X								
16	8550-008	Capacitor Strap												X				X		
17	8401-034	Compressor Contactor	X			X			X			X			X			X		
17	8401-035	Compressor Contactor		X	X		X	X		X	X		X	X		X	X		X	X
18	8615-038	Circuit Breaker 35A 2 Pole ②										X								
18	8615-039	Circuit Breaker 45A 2 Pole ②	X			X			X											
18	8615-051	Circuit Breaker 25A 3 Pole ②							X				X							
18	8615-054	Circuit Breaker 20A 3 Pole ②		X			X													
18	8615-055	Circuit Breaker 40A 2 Pole ②													X			X		
18	8615-083	Circuit Breaker 30A 3 Pole ②													X	X		X		
18	S8615-095	Toggle Disconnect			X			X		X			X			X			X	X
19	8615-058	Fuse Block			X			X		X			X			X				X
20	8611-210	Din Rail 2-1/2"			X			X		X			X			X				X
21	8607-017	Terminal Block			X			X		X			X			X				X
22	141-188	Heater Plug Bracket	X	X	X	X	X	X	X	X	X	X	X	X	X	X	X	X	X	X
23	8301-079-0003	EVD Control Board (Programmed )				X	X	X				X	X	X				X	X	X
NS	3000-1145	Blower Power Plug	X	X	X	X	X	X	X	X	X	X	X	X	X	X	X	X	X	X
NS	3000-1337	Compressor Wire Harness	X			X			X			X			X			X		
NS	3000-1338	Compressor Wire Harness		X	X		X	X		X	X		X	X		X	X		X	X
NS	3003-083	Control Panel Wire Harness				X						X						X		
NS	3003-084	Control Panel Wire Harness					X						X						X	
NS	3003-085	Control Panel Wire Harness						X						X						X
NS	3003-086	Control Panel Wire Harness	X						X						X					
NS	3003-087	Control Panel Wire Harness		X					X						X					
NS	3003-088	Control Panel Wire Harness			X					X						X				
NS	3003-1694	Upper Low Voltage Wire Harness	X	X	X	X	X	X	X	X	X	X	X	X	X	X	X	X	X	X
NS	8614-046	5A Class CC Fuse - with ERV installed ③			2			2		2			2			2			2	2
NS	8614-047	3.2A Class CC Fuse			2			2		2			2			2			2	2
NS	4096-126	Wiring Diagram	X						X						X					
NS	4096-226	Wiring Diagram		X						X						X				
NS	4096-326	Wiring Diagram			X						X						X			
NS	4096-127	Wiring Diagram				X					X							X		
NS	4096-227	Wiring Diagram					X					X							X	
NS	4096-327	Wiring Diagram						X					X							X

NS = Not Shown

X – Standard Component

① Only used for three phase units; single phase models use capacitors.

O – Optional Component

② Circuit breakers listed are for units without electric heat, "0Z" models. See heater replacement parts manual for units with electric heat.

③ Q\*\*H4-C models will have two (2) of the same fuse installed; part number is determined by the vent package installed.

# CONTROL PANEL COMPONENTS – QH STANDARD & DEHUMIDIFICATION

Dwg No.	Part Number	Description	Q43H4-A	Q43H4-B	Q43H4-C	Q43H4DA	Q43H4DB	Q43H4DC	Q48H4-A	Q48H4-B	Q48H4-C	Q48H4DA	Q48H4DB	Q48H4DC
1	517-429	Control Panel (sheet metal only)	X	X	X	X	X	X	X	X	X	X	X	X
2	117-424	Low Voltage Box	X	X	X	X	X	X	X	X	X	X	X	X
3	8607-063	Low Voltage Strip	X	X	X	X	X	X	X	X	X	X	X	X
4	8611-140-0903	Cable Duct - 9 3/16"	X	X	X	X	X	X	X	X	X	X	X	X
5	8611-140-3200	Cable Duct - 32"	X	X	X	X	X	X	X	X	X	X	X	X
6	8611-140-2704	Cable Duct - 27 1/4"	X	X	X	X	X	X	X	X	X	X	X	X
7	3000-1524	Vent Jumper Plug (used when no vent is installed)	X	X	X	X	X	X	X	X	X	X	X	X
8	8201-130	Blower Speed Relay	X	X	X	X	X	X	X	X	X	X	X	X
9	8201-086	OD T-Stat/LAC Relay	O	O	O	O	O	O	O	O	O	O	O	O
10	8408-028	Outdoor Thermostat	O	O	O	O	O	O	O	O	O	O	O	O
11	S8201-113	Dehumidification Logic Board				X	X	X				X	X	X
12	8620-223	Defrost Logic Control Board w/Sensor	X	X	X	X	X	X	X	X	X	X	X	X
13	8407-069	Transformer	X	X	X	X	X	X	X	X	X	X	X	X
14	S8201-126	Phase Monitor ①		X	X		X	X		X	X		X	X
15	8552-043	Compressor Capacitor	X			X								
15	8552-081	Compressor Capacitor							X			X		
16	8550-008	Capacitor Strap	X			X			X			X		
17	8401-034	Compressor Contactor	X			X			X			X		
17	8401-035	Compressor Contactor		X	X		X	X		X	X		X	X
18	8615-055	Circuit Breaker 40A 2 Pole ②	X			X			X			X		
18	8615-052	Circuit Breaker 30A 3 Pole ②		X			X			X			X	
18	S8615-095	Toggle Disconnect			X			X			X			X
19	8615-058	Fuse Block			X			X			X			X
20	8611-210	Din Rail 2-1/2"			X			X			X			X
21	8607-017	Terminal Block			X			X			X			X
22	141-188	Heater Plug Bracket	X	X	X	X	X	X	X	X	X	X	X	X
23	8301-079-0003	EVD Control Board (Programmed )				X	X	X				X	X	X
NS	3000-1145	Blower Power Plug	X	X	X	X	X	X	X	X	X	X	X	X
NS	3000-1337	Compressor Wire Harness	X			X			X			X		
NS	3000-1338	Compressor Wire Harness		X	X		X	X		X	X		X	X
NS	3003-083	Control Panel Wire Harness				X						X		
NS	3003-084	Control Panel Wire Harness					X						X	
NS	3003-085	Control Panel Wire Harness						X						X
NS	3003-086	Control Panel Wire Harness	X						X					
NS	3003-087	Control Panel Wire Harness		X						X				
NS	3003-088	Control Panel Wire Harness			X						X			
NS	3003-1694	Upper Low Voltage Wire Harness	X	X	X	X	X	X	X	X	X	X	X	X
NS	8614-046	5A Class CC Fuse - with ERV installed ③			2			2			2			2
NS	8614-047	3.2A Class CC Fuse			2			2			2			2
NS	4096-126	Wiring Diagram	X						X					
NS	4096-226	Wiring Diagram		X						X				
NS	4096-326	Wiring Diagram			X						X			
NS	4096-127	Wiring Diagram				X						X		
NS	4096-227	Wiring Diagram					X						X	
NS	4096-327	Wiring Diagram						X						X

NS = Not Shown

X – Standard Component

① Only used for three phase units; single phase models use capacitors.

O – Optional Component

② Circuit breakers listed are for units without electric heat, "OZ" models. See heater replacement parts manual for units with electric heat.

*This page intentionally left blank*

# BLOWER ASSEMBLY COMPONENTS – Q24/30\*4

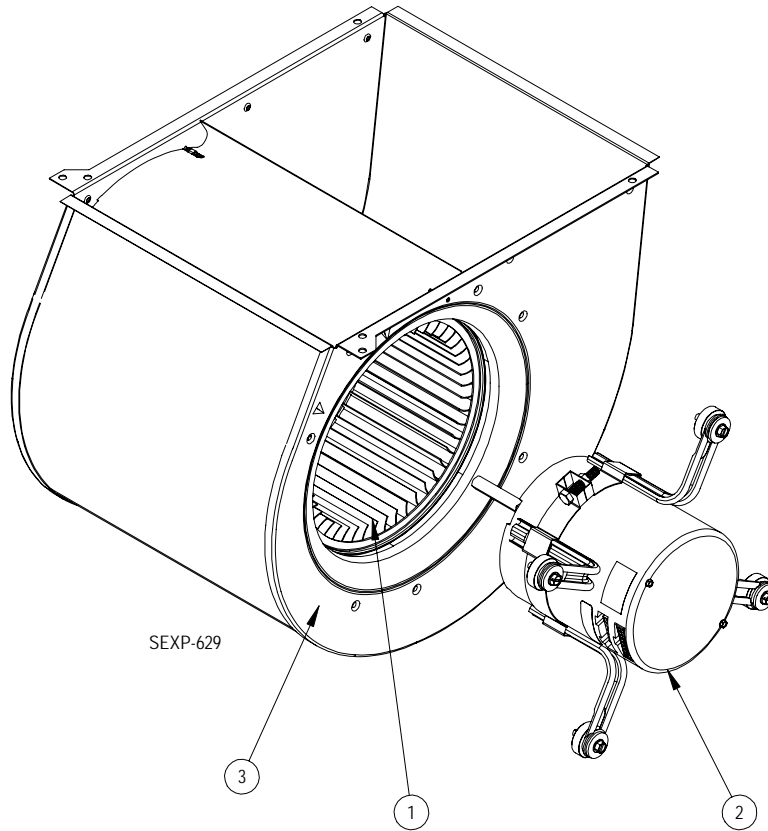

Dwg No.	Part Number	Description	5154-002-0211	5154-002-0212
1	5152-049	Blower Wheel	X	X
2	S8105-059-0211	1/3 HP Programmed Motor	X	
2	S8105-059-0212	1/3 HP Programmed Motor		X
3	151-122	Housing	X	X
NS	C8105-059-0211	1/3 HP Control Only Replacement	X	
NS	C8105-059-0212	1/3 HP Control Only Replacement		X



# BLOWER ASSEMBLY COMPONENTS – Q36/42/43/48\*4

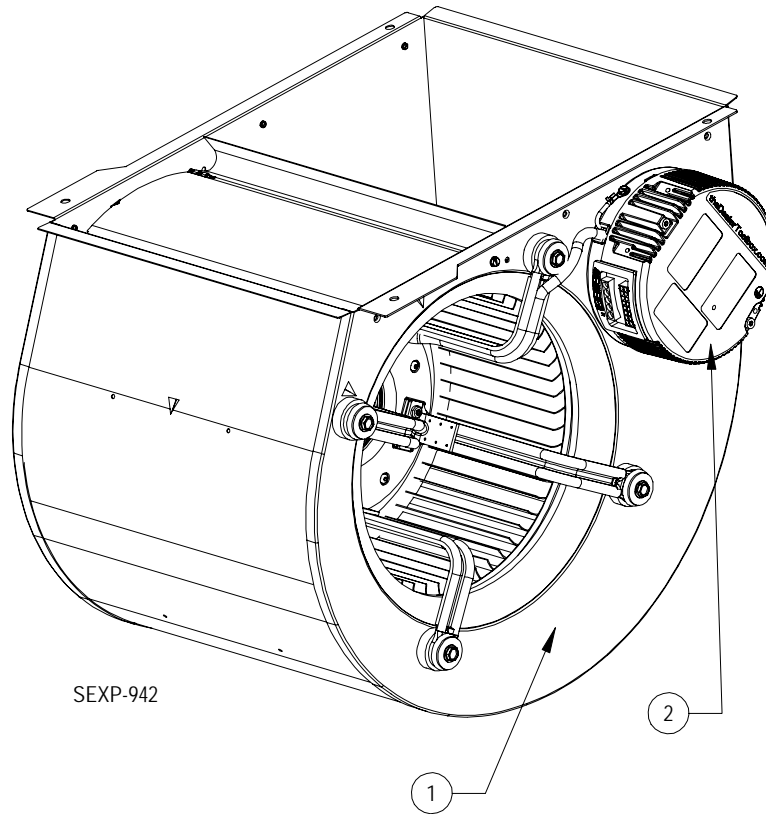

Dwg No.	Part Number	Description	5154-005-0210	5154-005-0215	5154-007-0216	5154-005-0228
1	5154-005-0210	Complete Blower Assembly	X			
1	5154-005-0215	Complete Blower Assembly		X		
1	5154-007-0216	Complete Blower Assembly			X	
1	5154-005-0228	Complete Blower Assembly				X
2	C5154-005-0210	1/2 HP Programmed Motor	X			
2	C5154-005-0215	1/2 HP Programmed Motor		X		
2	C5154-007-0216	3/4 HP Programmed Motor			X	
2	C5154-005-0228	1/2 HP Programmed Motor				X