

---

# REPLACEMENT PARTS MANUAL

---

## Commercial Room Ventilator with Spring Return and Exhaust

Model:  
QCRV-F3

---

### General Notes

- Revised and/or additional pages may be issued from time to time.
- A complete and current manual consists of pages shown in the following contents section.

### Important

- Contact the installing and/or local distributor for all parts requirements. Make sure to have the complete model and serial number available from the unit rating plates.

### Contents

Description	Page
QCRV-F3 Commercial Room Ventilator	
♦ Exploded View .....	2
♦ Usage List .....	3
Blade Assembly	
♦ Exploded View .....	4
♦ Usage List .....	5

---

BMC, Inc.  
Bryan, Ohio 43506

Manual: 2110-1569  
Supersedes: **NEW**  
Date: 9-17-20

# QCRV-F3 COMMERCIAL ROOM VENTILATOR

---

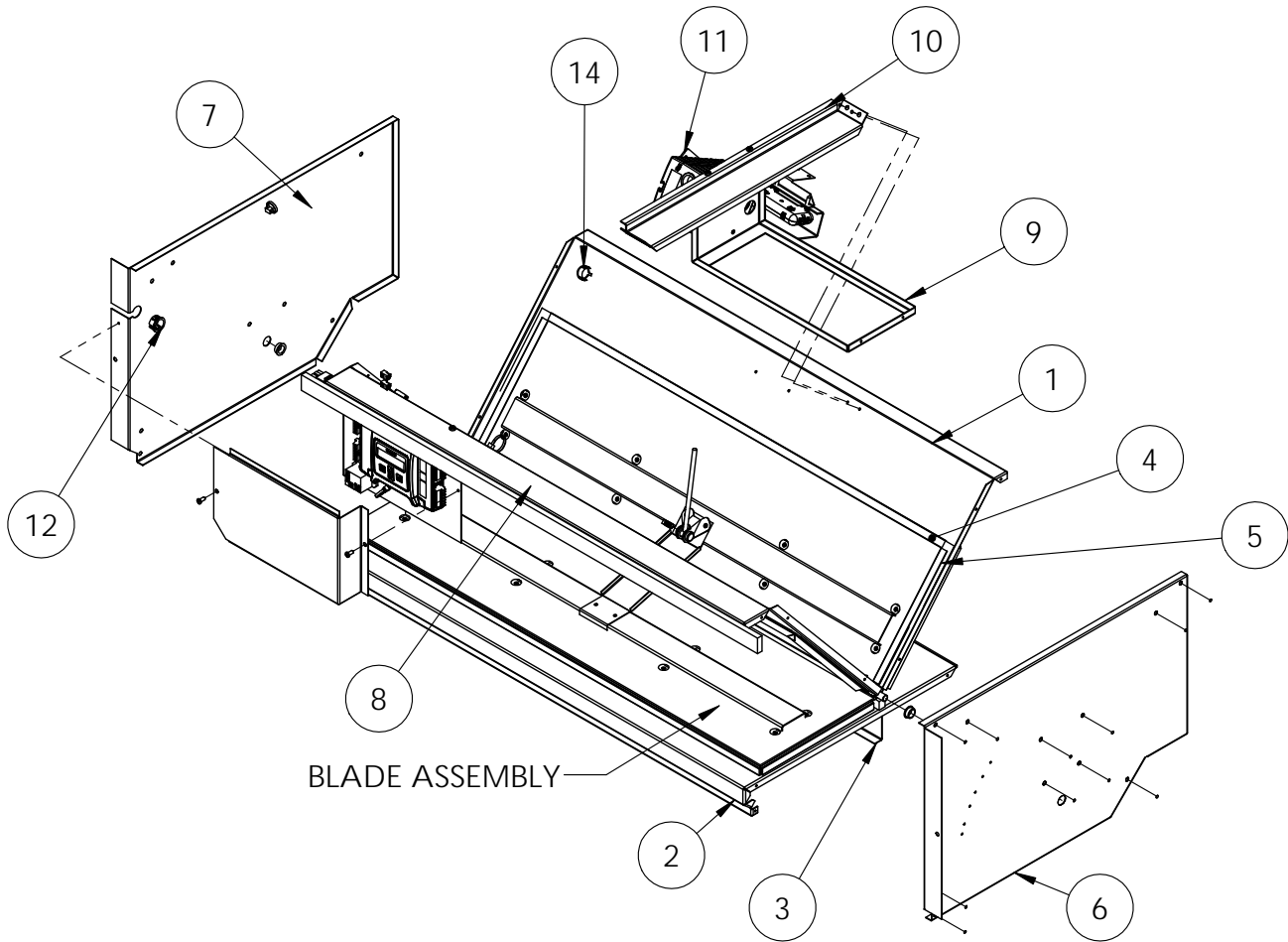

SEXP-1026

## QCRV-F3 COMMERCIAL ROOM VENTILATOR

---

Drawing No.	Part No.	Description	CRV-F3
1	137-981	Upper Rear Fill	X
2	137-980	Base	X
3	141-525	Base Support	X
4	1921-067-3300	Damper Blade Seal	2
5	1921-067-0814	Damper Blade Seal	4
6	101-1090	Right CRV Side	X
7	101-1091	Left CRV Side	X
8	137-982	Upper Front	X
9	141-516	Actuator Mounting Bracket	X
10	141-515	Actuator Support Angle	X
11	8602-094	Actuator	X
12	1012-192	Nylon Spacer	2
13	1012-074	Screw #8-18-1	2
14	8611-047	Split Bushing	3

# BLADE ASSEMBLY

---

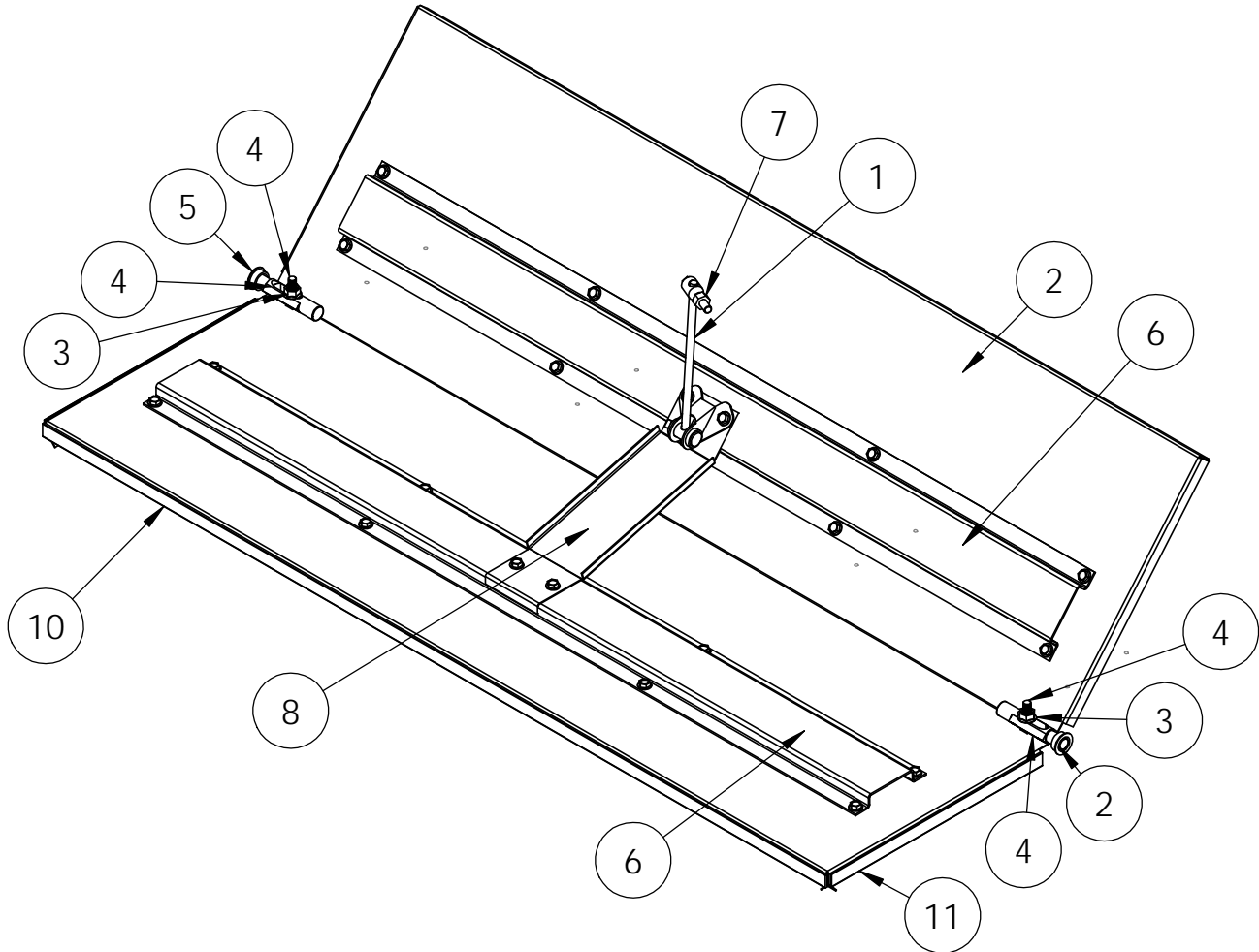

SEXP-1028

# BLADE ASSEMBLY

---

Drawing No.	Part No.	Description	CRV-F3
1	8602-042	1/4" X 6" Rod	X
2	139-435	Blade	X
3	1012-221	1/4-20 Hex Flange Nut	2
4	8602-038	Damper Pin with Hardware	2
5	8602-052	1/2" Bronze Bushing	2
6	141-514	Blade Support	2
7	8602-008	Ball Joint	X
8	141-525	Support Angle	X
9	8602-040	BKP-24 Bracket	X
10	1921-067-3408	Damper Blade Seal	X
11	1921-067-0905	Damper Blade Seal	2