REPLACEMENT PARTS MANUAL

PACKAGE AIR CONDITIONER

Models:

P1124A1 P1130A1
P1136A1 P1136A1-A/H
P1136A1-B/H P1136A1-C/H

General Notes

- Revised and/or additional pages may be issued from time to time.
- A complete and current manual consists of pages shown in the following contents section.

Important

- Contact the installing and/or local Bard distributor for all parts requirements. Make sure you have the complete model and serial number available from the unit rating plates.

Contents

Description	Page
Cabinet Components	
♦ Exploded View	1
♦ Usage List	2
Functional Components	
♦ Exploded View	3
♦ Usage List	4
♦ Exploded View	5
♦ Usage List	6
Control Panel	
♦ Exploded View	7
♦ Usage List	8
♦ Exploded View	9
♦ Usage List	10



BARD MANUFACTURING COMPANY
Bryan, Ohio 43506
Since 1914...Moving, ahead just as planned.

Manual: 2110-207 K
Supersedes: 2110-207 J
File: Tab 10
Date: 04-01-02

CABINET COMPONENTS

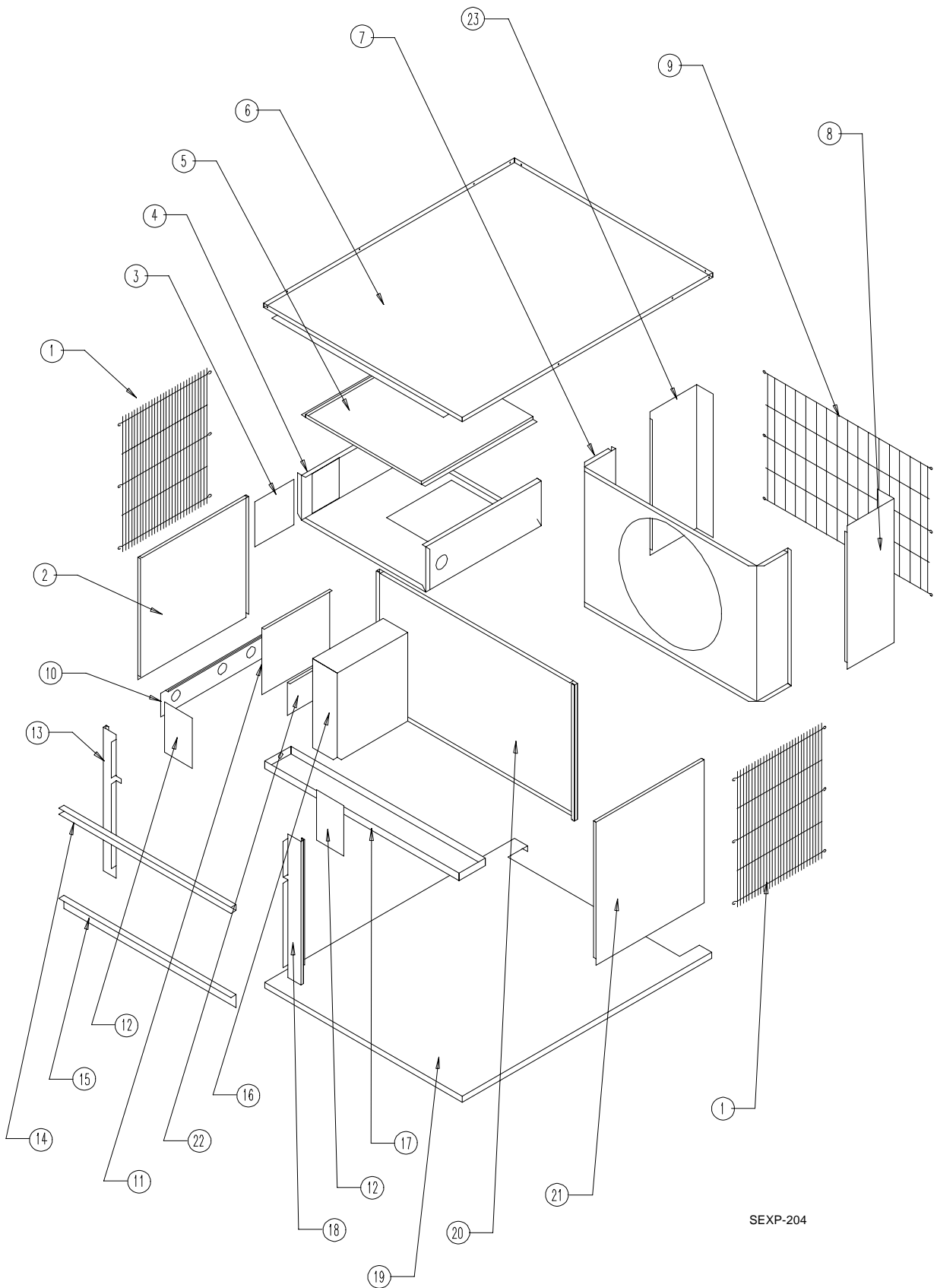

SEXP-204

CABINET COMPONENTS

Drawing No.	Part No.	Description	P1124A1	P1130A1	P1136A1, -A/H, -B/H, -C/H
1	7051-015	Inlet Grille	2	2	2
2	501-133-X	Left Side	X	X	X
3	142-017	Cover Plate – OKW	X	X	X
4	520-284	Blower Partition	X		
4	520-286	Blower Partition		X	X
5	134-017	Heat Strip	X	X	X
6	507-168-X	Top	X	X	X
7	125-012-X	Fan Shroud	X	X	X
8	149-085-X	Right Rear Corner	X	X	X
9	7051-001	Condenser Grille	X	X	X
10	557-028-X	Entrance Panel	X	X	X
11	133-035-X	Control Panel Cover	X	X	X
12	136-312	Blower Fill Plates	2	2	2
13	549-082-X	Left Front Cover	X	X	X
14	165-552-X	Plenum Channel	X	X	X
15	105-521-X	Plenum Angle	X	X	X
16	Control Panel Assembly	See Control Panel Drawing & Parts List	X	X	X
17	123-088-X	Drain Pan	X	X	X
18	549-081-X	Right Front Corner	X	X	X
19	527-255	Base	X	X	X
20	521-283-X	Compressor Partition	X	X	X
21	501-132-X	Right Side	X	X	X
22	142-016	Entrance Cover	X	X	X
23	149-086-X	Left Rear Corner	X	X	X

FUNCTIONAL COMPONENTS

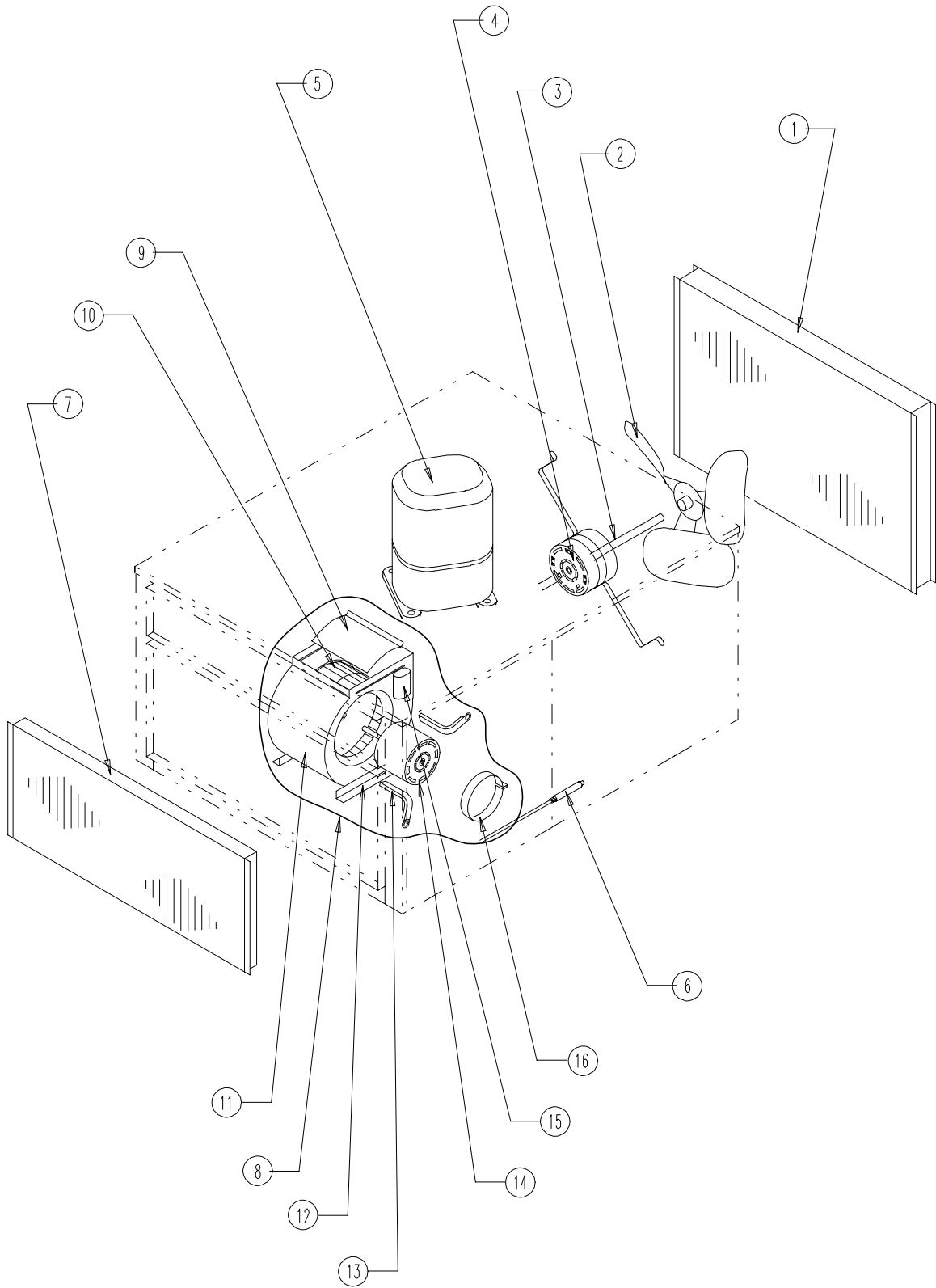

SEXP-283

FUNCTIONAL COMPONENTS

Drawing No.	Part No.	Description	P1124A1	P1124A1-D	P1130A1	P1130A1-D	P1136A1	P1136A1-B	P1136A1-C	P1136A1-D
1	5051-035	Condenser Coil	X	X	X	X				
1	5051-050	Condenser Coil					X	X	X	X
2	5151-034	Fan Blade	X	X						
2	5151-004	Fan Blade			X	X	X	X	X	X
3	8200-001	Motor Mount	X	X	X	X	X	X	X	X
4	8103-014	Motor							X	
4	8103-016	Motor	X	X						
4	8103-019	Motor			X	X	X	X		X
5	8000-116	Compressor	X							
5	8000-117	Compressor			X					
5	8000-115	Compressor					X			
5	8000-163	Compressor						X		
5	8000-164	Compressor							X	
5	8000-169	Compressor		X						
5	8000-173	Compressor				X				
5	8000-184	Compressor								X
6	800-0049	Capillary Tube Assembly	X	X	X	X				
6	800-0159	Capillary Tube Assembly					X	X	X	X
7	5060-037	Evaporator Coil	X	X	X	X				
7	5060-050	Evaporator Coil					X	X	X	X
8	900-146	Complete Blower Assembly	X	X						
8	900-145	Complete Blower Assembly			X	X	X	X		X
8	900-207	Complete Blower Assembly							X	
9	144-126	Diffuser	X	X	X	X	X	X	X	X
10	5152-005	Blower Wheel			X	X	X	X	X	X
10	5152-065	Blower Wheel	X	X						
11	151-088	Blower Housing	X	X						
11	151-068	Blower Housing			X	X	X	X	X	X
12	104-787	Blower Angles	X	X	X	X	X	X	X	X
13	8200-036	Motor Mount Arms	3	3						
13	8200-034	Motor Mount Arms			3	3	3	3	3	3
14	8105-016	Motor							X	
14	8105-032	Motor	X	X						
14	8105-024	Motor			X	X	X	X		X
15	8552-002	Capacitor 5/370	X	X	X	X	X	X	X	X
16	8200-033	Motor Mount Band	X	X	X	X	X	X	X	X

FUNCTIONAL COMPONENTS

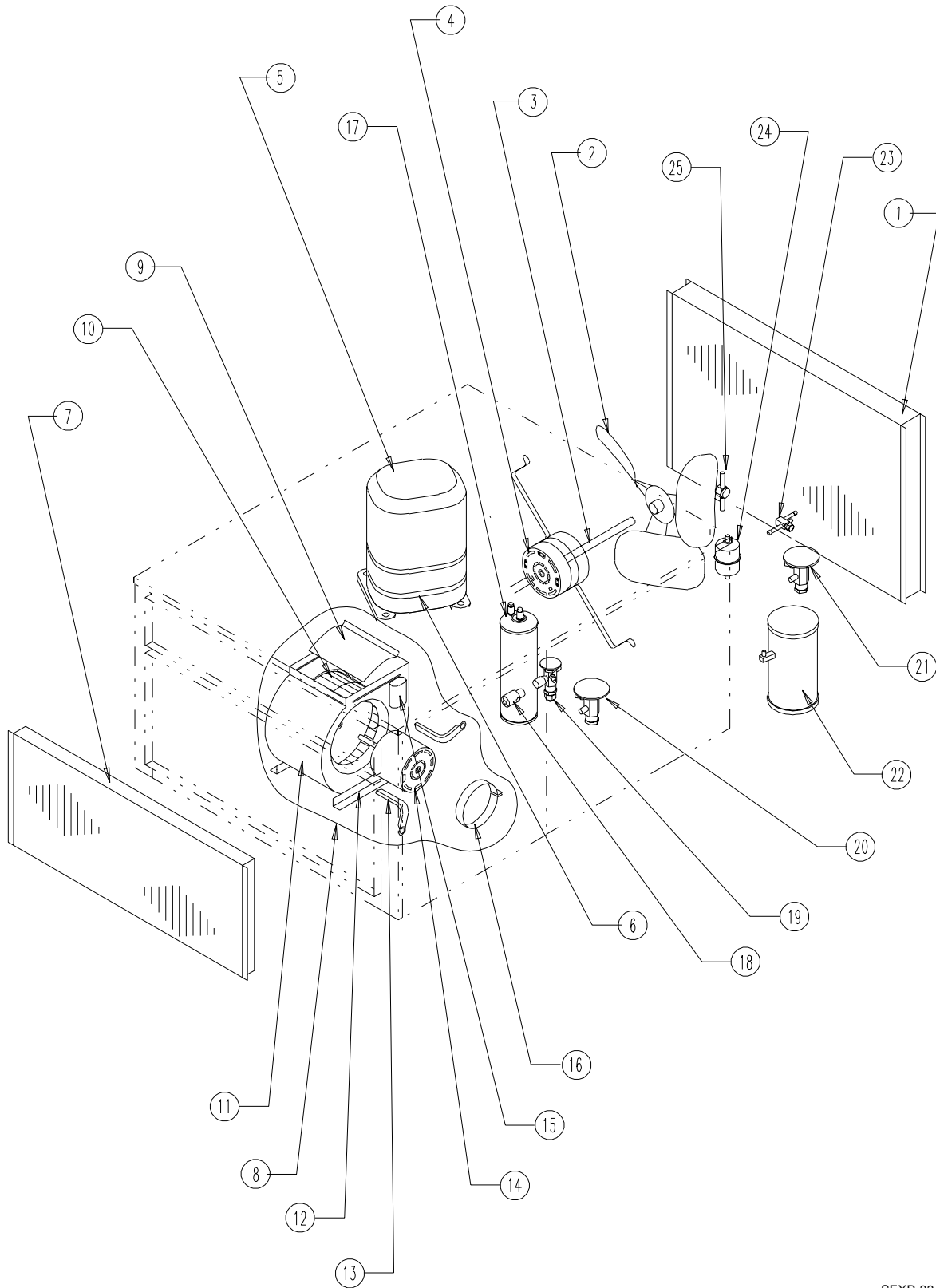

SEXP-334

FUNCTIONAL COMPONENTS

Drawing			P1136A1-A/H	P1136A1-B/H	P1136A1-C/H
No.	Part No.	Description			
1	5051-050	Condenser Coil	X	X	X
2	5151-004	Fan Blade	X	X	X
3	8200-001	Motor Mount	X	X	X
4	8103-014	Motor			X
4	8103-019	Motor	X	X	
5	8000-175	Compressor	X		
5	8000-163	Compressor		X	
5	8000-164	Compressor			X
6	8605-015	Crankcase Heater	X	X	
6	8605-016	Crankcase Heater			X
7	5060-050	Evaporator Coil	X	X	X
8	900-145	Complete Blower Assembly	X	X	
8	900-207	Complete Blower Assembly			X
9	144-126	Diffuser	X	X	X
10	5152-005	Blower Wheel	X	X	X
11	151-068	Blower Housing	X	X	X
12	104-787	Blower Angles	X	X	X
13	8200-034	Motor Mount Arms	3	3	3
14	8105-016	Motor			X
14	8105-024	Motor	X	X	
15	8552-002	Capacitor 5/370	X	X	X
16	8200-033	Motor Mount Band	X	X	X
17	5202-022	Accumulator	X	X	X
18	5651-098	Distributor	X	X	X
19	5651-100	Expansion Valve	X	X	X
20	5651-014	Hot Gas Bypass Valve	X	X	X
21	5651-097	Head Pressure Control Valve	X	X	X
22	5203-004	Receiver	X	X	X
23	5651-051	Manual Shut Off Valve	X	X	X
24	5201-001	Liquid Line Filter Drier	X	X	X
25	5201-014	Sight Glass	X	X	X

CONTROL PANEL

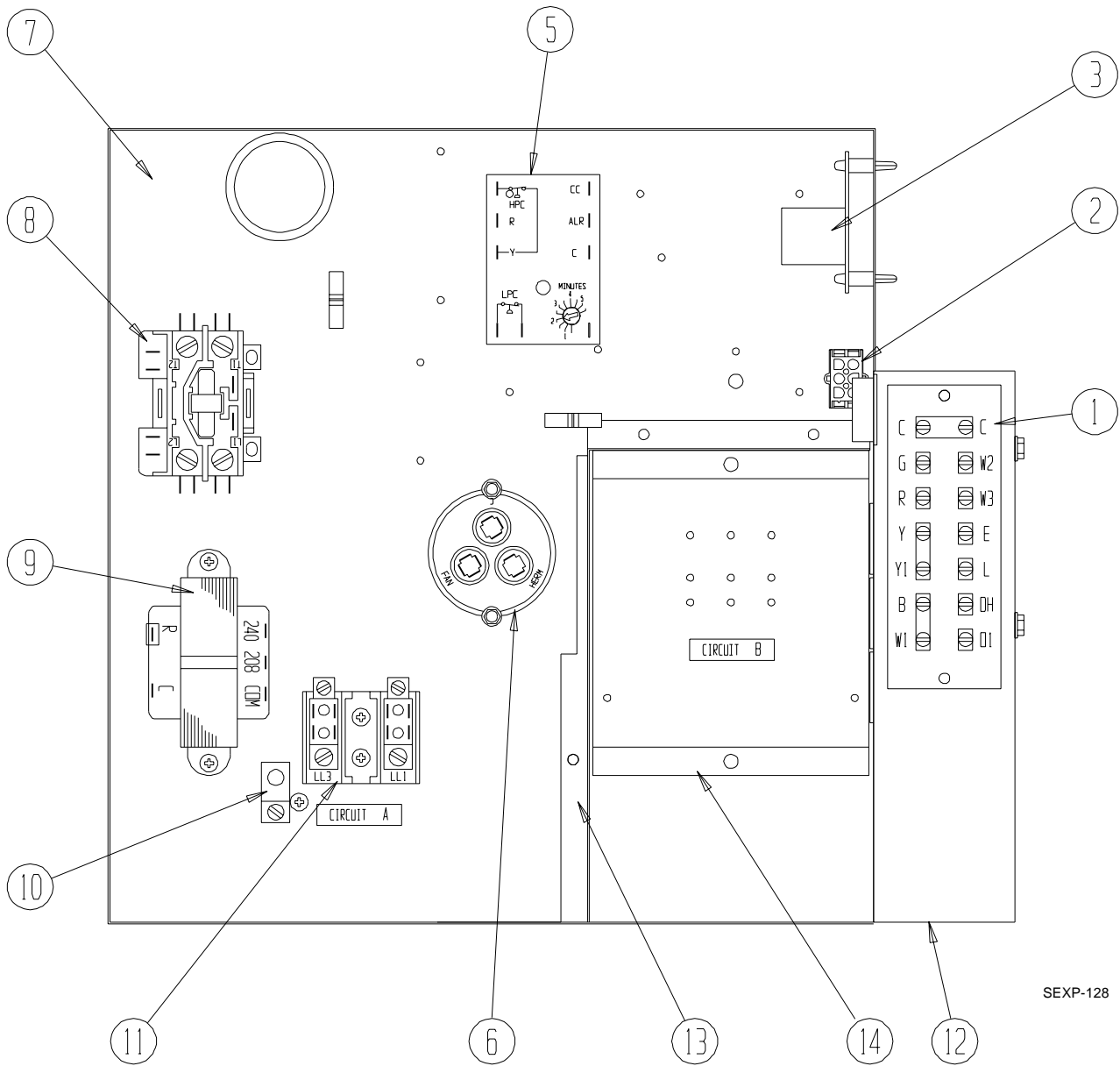

SEXP-128

CONTROL PANEL

Drawing No.	Part No.	Description	P1124A1	P1124A1-D	P1130A1	P1136A1	P1130A1-D
1	8607-025	Terminal Strip	X	X	X	X	X
2	3000-988	Wire Assembly			X	X	X
2	3000-1027	Wire Assembly	X	X			
3	8201-056	Blower Relay	X	X	X	X	X
5	8201-088	Compressor Control Module	X	X	X	X	X
6	8552-048	Capacitor 35/5 – 370			X		X
6	8552-049	Capacitor 35/5 – 440				X	
6	8552-047	Capacitor 30/5 – 370	X	X			
7	516-147	Control Panel	X	X	X	X	X
8	8401-007	Contactors	X	X	X	X	X
9	8407-034	Transformer	X	X	X	X	X
10	8611-006	Ground Terminal	X	X	X	X	X
11	8407-013	Terminal Block	X	X	X	X	X
12	116-148	Low Voltage Box	X	X	X	X	X
13	116-149	Control Panel Partition	X	X	X	X	X
14	116-150	Terminal Block Support	X	X	X	X	X
NS	4063-127	Wiring Diagram			X	X	X
NS	4063-126	Wiring Diagram	X	X			

NS Not Shown

CONTROL PANEL

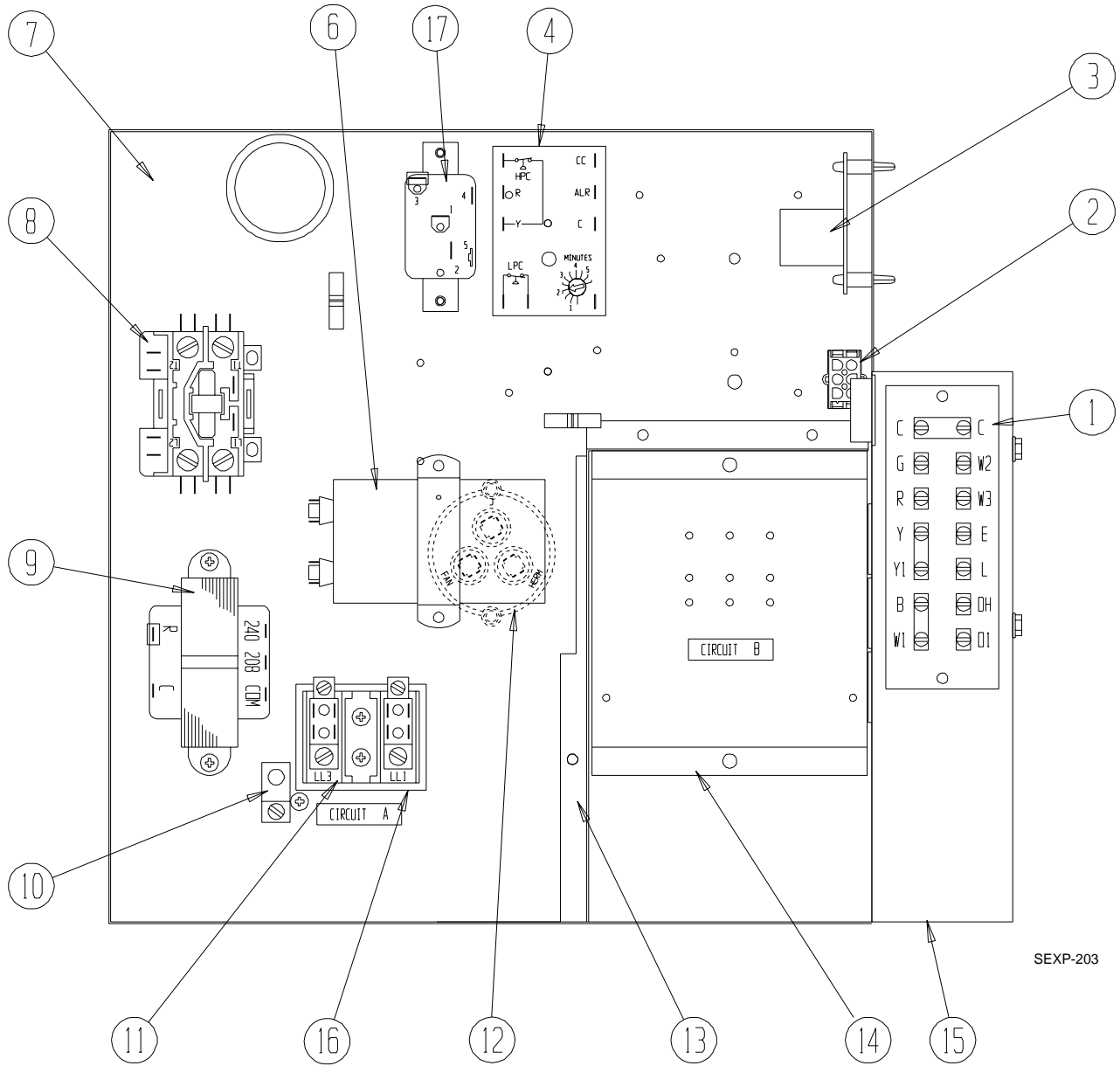

SEXP-203

CONTROL PANEL

Drawing No.	Part No.	Description	P1136A1-B	P1136A1-C	P1136A1-D	P1136A1-A/H	P1136A1-B/H	P1136A1-C/H
1	8607-025	Terminal Strip	X	X	X	X	X	X
2	3000-988	Wire Assembly	X	X	X	X	X	X
3	8201-056	Solid State Blower Control	X		X	X	X	
3	8201-032	Blower Relay		X				X
4	8201-088	Compressor Control Module	X	X	X	X	X	X
6	8552-002	Capacitor 5 – 370	X	X		X	X	
7	516-147	Control Panel	X	X	X	X	X	X
8	8401-002	Contactora	X	X			X	X
8	8401-007	Contactora			X	X		
9	8407-034	Transformer	X		X	X	X	
9	8407-042	Transformer		X				X
10	8611-006	Ground Terminal	X	X	X	X	X	X
11	8607-013	Terminal Block			X			
11	8607-014	Terminal Block	X	X		X	X	X
12	8552-063	Capacitor 50/5 – 370			X	X		
13	116-149	Control Panel Partition	X	X	X	X	X	X
14	116-150	Terminal Block Support	X	X	X	X	X	X
15	116-148	Low Voltage Box	X	X	X	X	X	X
16	8607-015	Phenolic Insulator		X				X
17	8201-009	Relay (CC Heater)				X	X	
17	8201-032	Relay (CC Heater)						X
NS	4063-125	Wiring Diagram			X			
NS	4063-213	Wiring Diagram	X					
NS	4063-311	Wiring Diagram		X				
NS	4063-128	Wiring Diagram				X		
NS	4063-214	Wiring Diagram					X	
NS	4063-312	Wiring Diagram						X

NS Not Shown