REPLACEMENT PARTS MANUAL

PACKAGE AIR CONDITIONER

Models: **P1224A1**
P1230A1
P1236A1

General Notes

- Revised and/or additional pages may be issued from time to time.
- A complete and current manual consists of pages shown in the following contents section.

Important

- Contact the installing and/or local Bard distributor for all parts requirements. Make sure you have the complete model and serial number available from the unit rating plates.

Contents

Description	Page
Cabinet Components	
♦ Exploded View	1
♦ Usage List	2
Functional Components	
♦ Exploded View	3
♦ Usage List	4
Control Panel	
♦ Exploded View	5
♦ Usage List	6
♦ Exploded View	7
♦ Usage List	8



BARD MANUFACTURING COMPANY
Bryan, Ohio 43506
Since 1914...Moving, ahead just as planned.

Manual: 2110-214D
Supersedes: 2110-214C
File: Tab 10
Date: 04-01-02

CABINET COMPONENTS

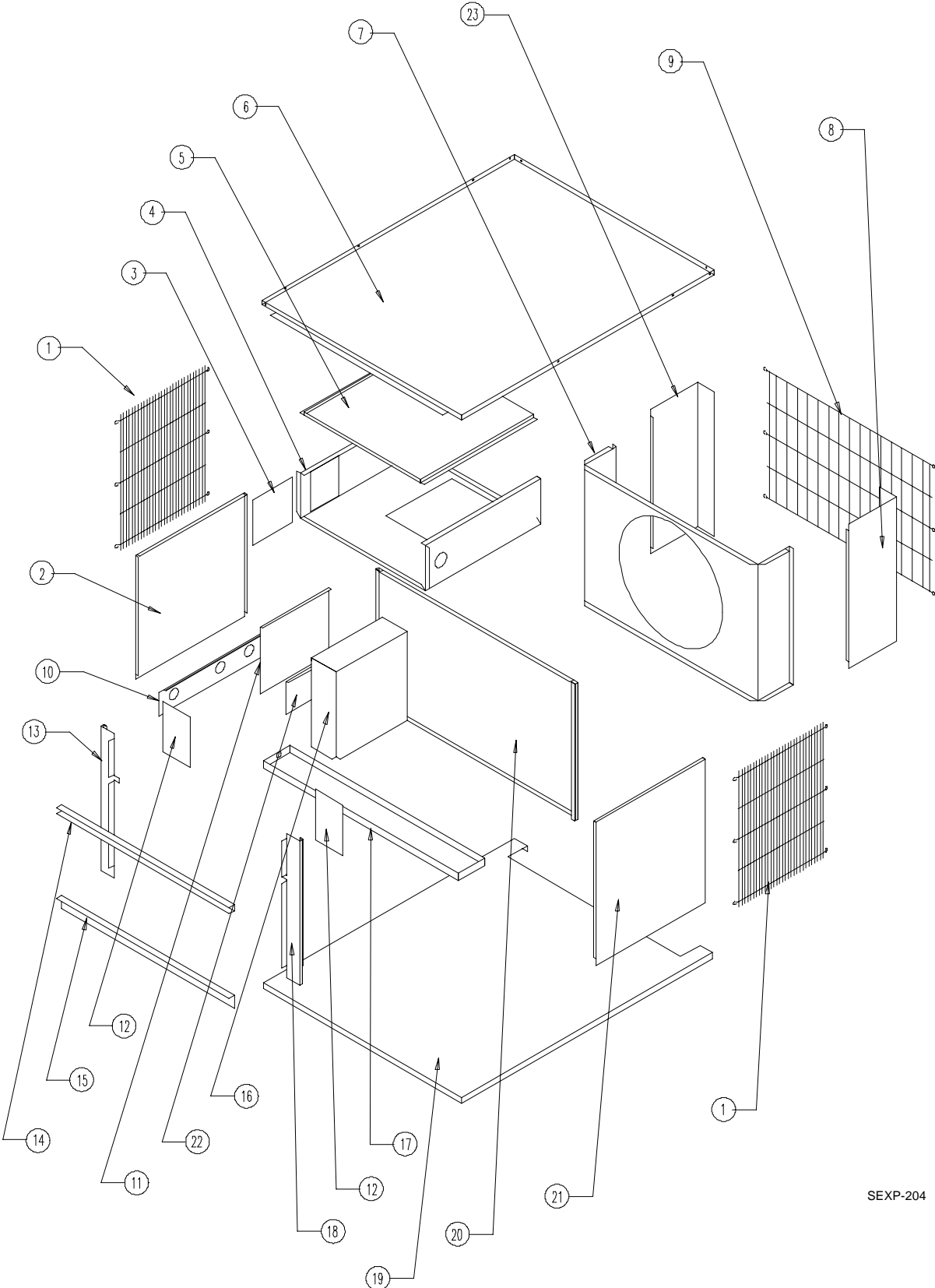

SEXP-204

CABINET COMPONENTS

Drawing No.	Part No.	Description	P1224A1	P1230A1	P1236A1
1	7051-015	Inlet Grille	2	2	2
2	501-133-X	Left Side	X	X	X
3	142-017	Cover Plate – OKW	X	X	X
4	520-330	Blower Partition	X	X	X
5	134-017	Heat Strip	X	X	X
6	507-168-X	Top	X	X	X
7	125-012-X	Fan Shroud	X	X	X
8	149-085-X	Right Rear Corner	X	X	X
9	7051-001	Condenser Grille	X	X	X
10	557-028-X	Entrance Panel	X	X	X
11	133-035-X	Control Panel Cover	X	X	X
12	136-312	Blower Fill Plates	2	2	2
13	549-082-X	Left Front Cover	X	X	X
14	165-552-X	Plenum Channel	X	X	X
15	105-521-X	Plenum Angle	X	X	X
16	Control Panel Assembly	See Control Panel Drawing & Parts List	X	X	X
17	123-088-X	Drain Pan	X	X	X
18	549-081-X	Right Front Corner	X	X	X
19	527-255	Base	X	X	X
20	521-328-X	Compressor Partition	X	X	X
21	501-132-X	Right Side	X	X	X
22	142-016	Entrance Cover	X	X	X
23	149-086-X	Left Rear Corner	X	X	X

FUNCTIONAL COMPONENTS

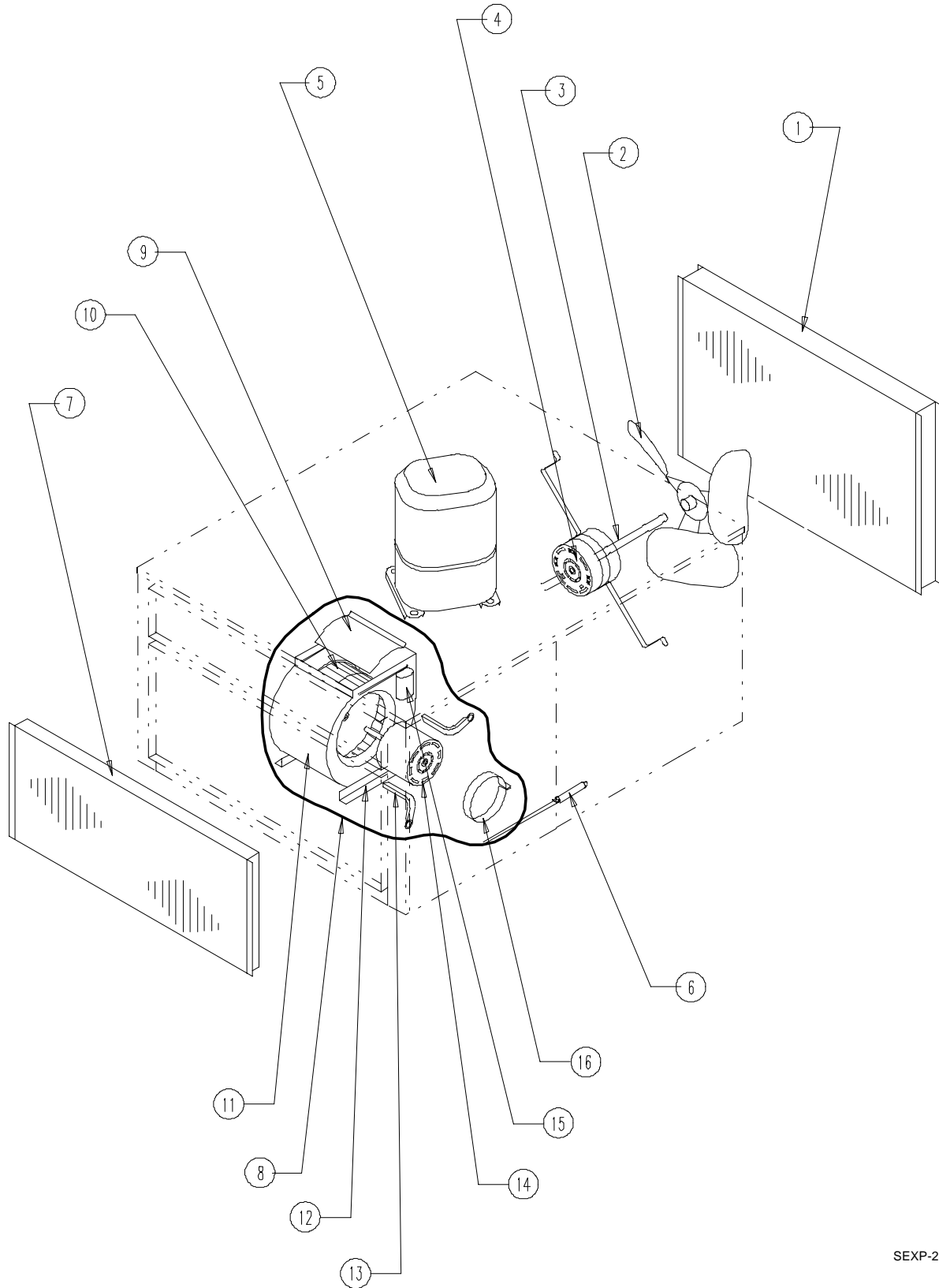

SEXP-283

FUNCTIONAL COMPONENTS

Drawing No.	Part No.	Description	P1224A1	P1230A1	P1236A1	P1236A1-B
1	5051-035	Condenser Coil	X			
1	5051-050	Condenser Coil		X	X	X
2	5151-034	Fan Blade	X			
2	5151-004	Fan Blade		X	X	X
3	8200-001	Motor Mount	X	X	X	X
4	8103-016	Motor	X			
4	8103-019	Motor		X	X	X
5	8000-170	Compressor	X			
5	8000-172	Compressor		X		
5	8000-175	Compressor			X	
5	8000-163	Compressor				X
6	800-0049	Capillary Tube Assembly	X			
6	800-0283	Capillary Tube Assembly		X		
6	800-0159	Capillary Tube Assembly			X	X
7	5060-037	Evaporator Coil	X	X		
7	5060-100	Evaporator Coil			X	X
8	900-239-001	Complete Blower Assembly	X			
8	900-240-001	Complete Blower Assembly		X		
8	900-240-002	Complete Blower Assembly			X	X
9	144-126	Diffuser	X	X	X	X
10	5152-049	Blower Wheel	X	X	X	X
11	151-097	Blower Housing	X	X	X	X
12	104-1043	Blower Angles	X	X	X	X
13	8200-034	Motor Mount Arms	3	3	3	3
14	8105-045-0016	Motor	X			
14	8105-035-0017	Motor		X		
14	8105-035-0021	Motor			X	X
16	8200-033	Motor Mount Band	X	X	X	X

CONTROL PANEL

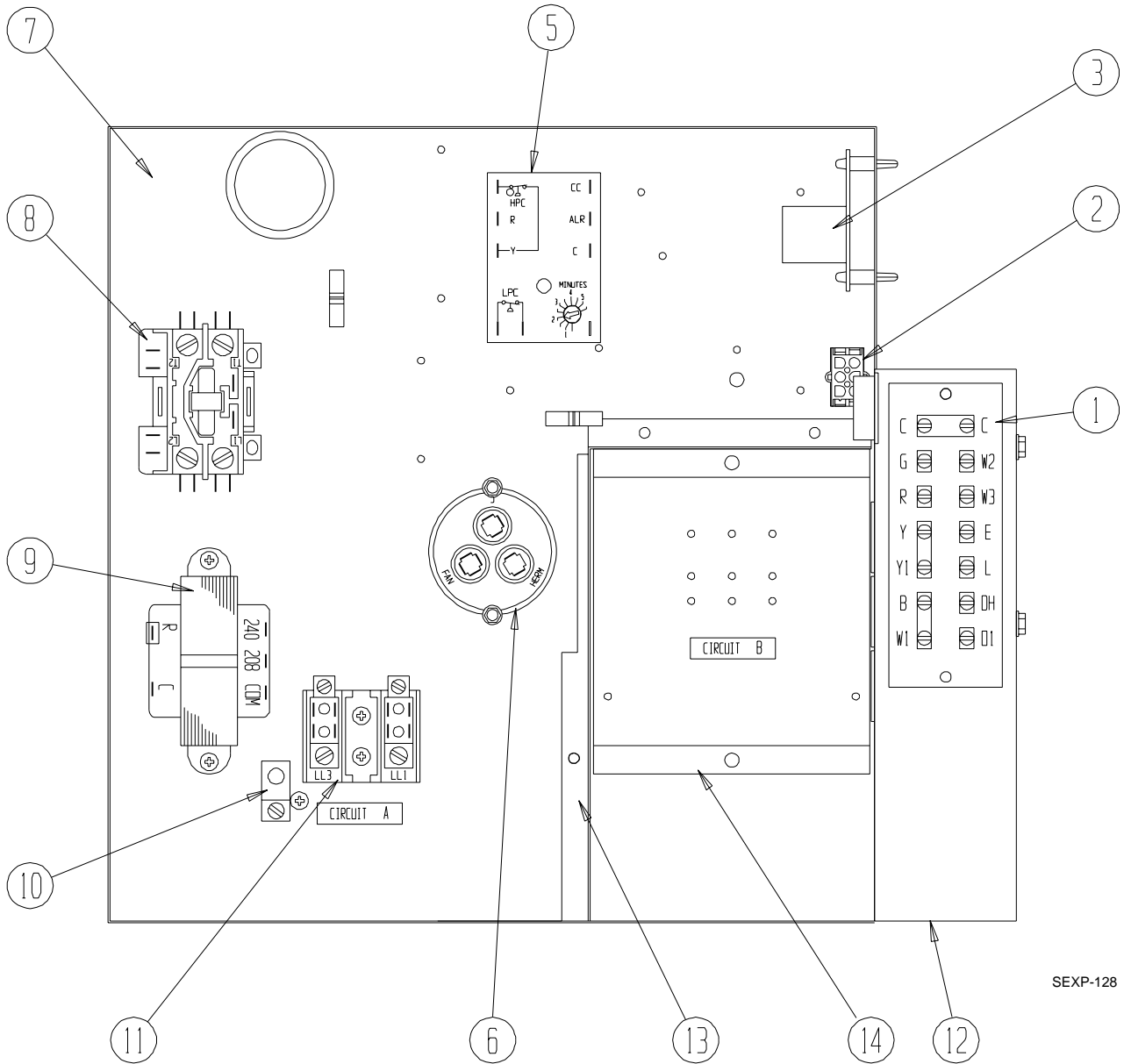

SEXP-128

CONTROL PANEL

Drawing No.	Part No.	Description	P1224A1	P1230A1	P1236A1
1	8607-025	Terminal Strip	X	X	X
2	3000-1099	Wire Assembly	X	X	X
3	8201-074	Blower Interlock Relay	X	X	X
5	8201-088	Compressor Control Module	X	X	X
6	8552-052	Capacitor 45/5 – 370	X	X	
6	8552-063	Capacitor 50/5 – 370			X
7	516-147	Control Panel	X	X	X
8	8401-007	Contacto	X	X	X
9	8407-034	Transformer	X	X	X
10	8611-006	Ground Terminal	X	X	X
11	8407-013	Terminal Block	X	X	X
12	116-148	Low Voltage Box	X	X	X
13	116-149	Control Panel Partition	X	X	X
14	116-150	Terminal Block Support	X	X	X
NS	1804-0106	Service Replacement High Pressure Switch	X	X	X
NS	4063-131	Wiring Diagram	X	X	X

NS = Not Shown

CONTROL PANEL

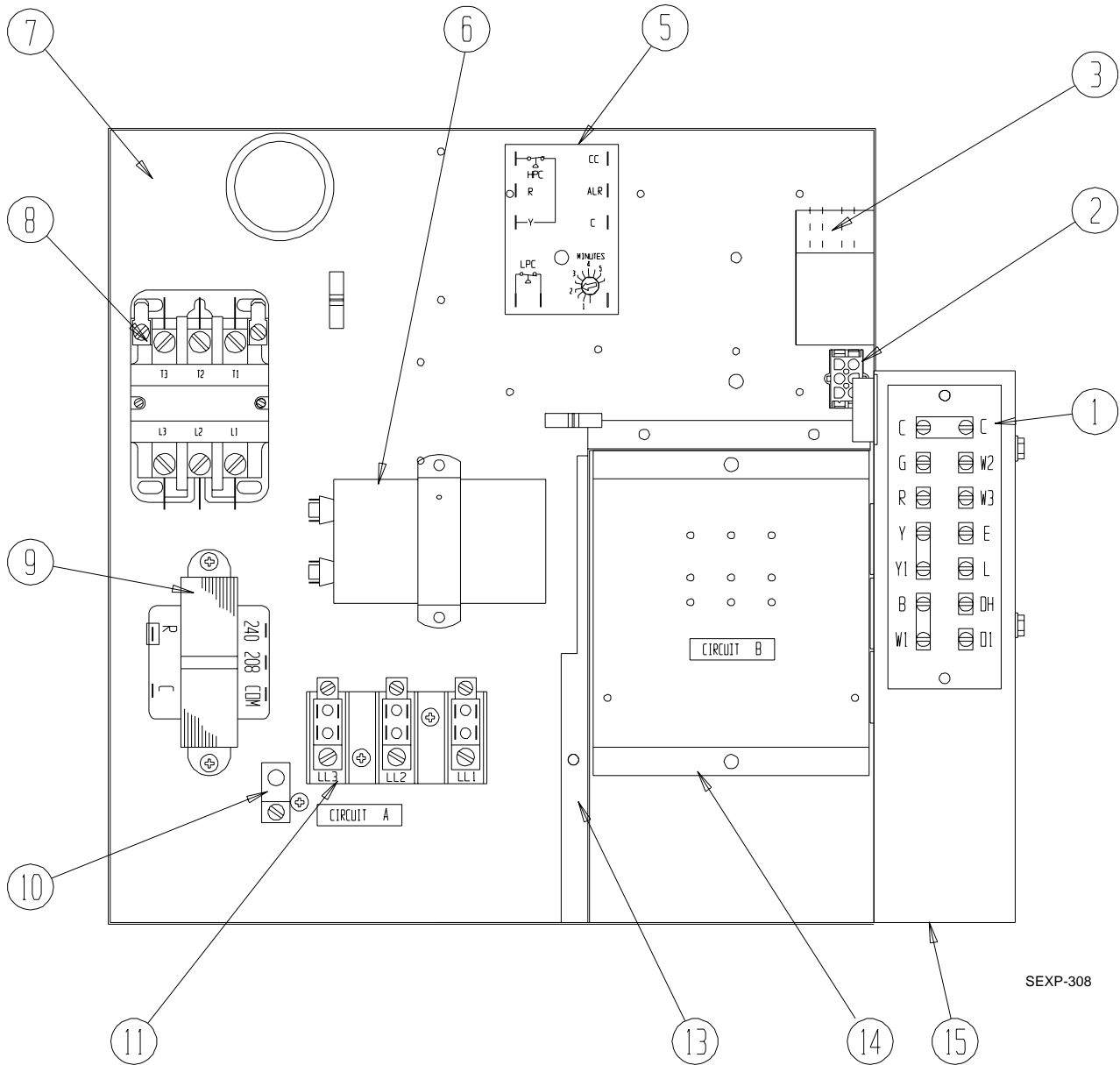

SEXP-308

CONTROL PANEL

Drawing No.	Part No.	Description	P1236A1-B	
1	8607-025	Terminal Strip	X	
2	3000-1099	Wire Assembly	X	
3	8201-074	Blower Interlock Relay	X	
5	8201-088	Compressor Control Module	X	
6	8552-002	Capacitor 5 – 370	X	
7	516-147	Control Panel	X	
8	8401-002	Contacto	X	
9	8407-034	Transformer	X	
10	8611-006	Ground Terminal	X	
11	8607-014	Terminal Block	X	
13	116-149	Control Panel Partition	X	
14	116-150	Terminal Block Support	X	
15	116-148	Low Voltage Box	X	
NS	1804-0106	Service Replacement High Pressure Switch	X	
NS	4063-215	Wiring Diagram	X	

NS = Not Shown