

---

# REPLACEMENT PARTS MANUAL

# PACKAGE AIR CONDITIONER

## Models:

**P60RV1-R**  
**P72RV1-S**  
**P72RV1-T**

**P60LV1-R**  
**P72LV1-S**  
**P72LV1-T**

---

## General Notes

- Revised and/or additional pages may be issued from time to time.
- A complete and current manual consists of pages shown in the following contents section.

## Important

- Contact the installing and/or local Bard distributor for all parts requirements. Make sure you have the complete model and serial number available from the unit rating plates.

## Contents

Description	Page
Cabinet Components – Right Hand	
♦ Exploded View .....	2
♦ Usage List .....	3
Cabinet Components – Left Hand	
♦ Exploded View .....	4
♦ Usage List .....	5
Functional Components	
♦ Exploded View .....	6
♦ Usage List .....	7
Control Panels	
♦ Exploded View -R (1-Phase) .....	8
♦ Usage List -R (1-Phase) .....	9
♦ Exploded View -S (3-Phase) .....	10
♦ Usage List -S (3-Phase) .....	11
♦ Exploded View -T (3-Phase) .....	12
♦ Usage List -T (3-Phase) .....	13



Bard Manufacturing Company, Inc.  
Bryan, Ohio 43506  
*Since 1914...Moving, ahead just as planned.*

Manual: 2110-219B  
Supersedes: 2110-219A  
File: Tab 10  
Date: 03-08-11

# CABINET COMPONENTS — RIGHT HAND

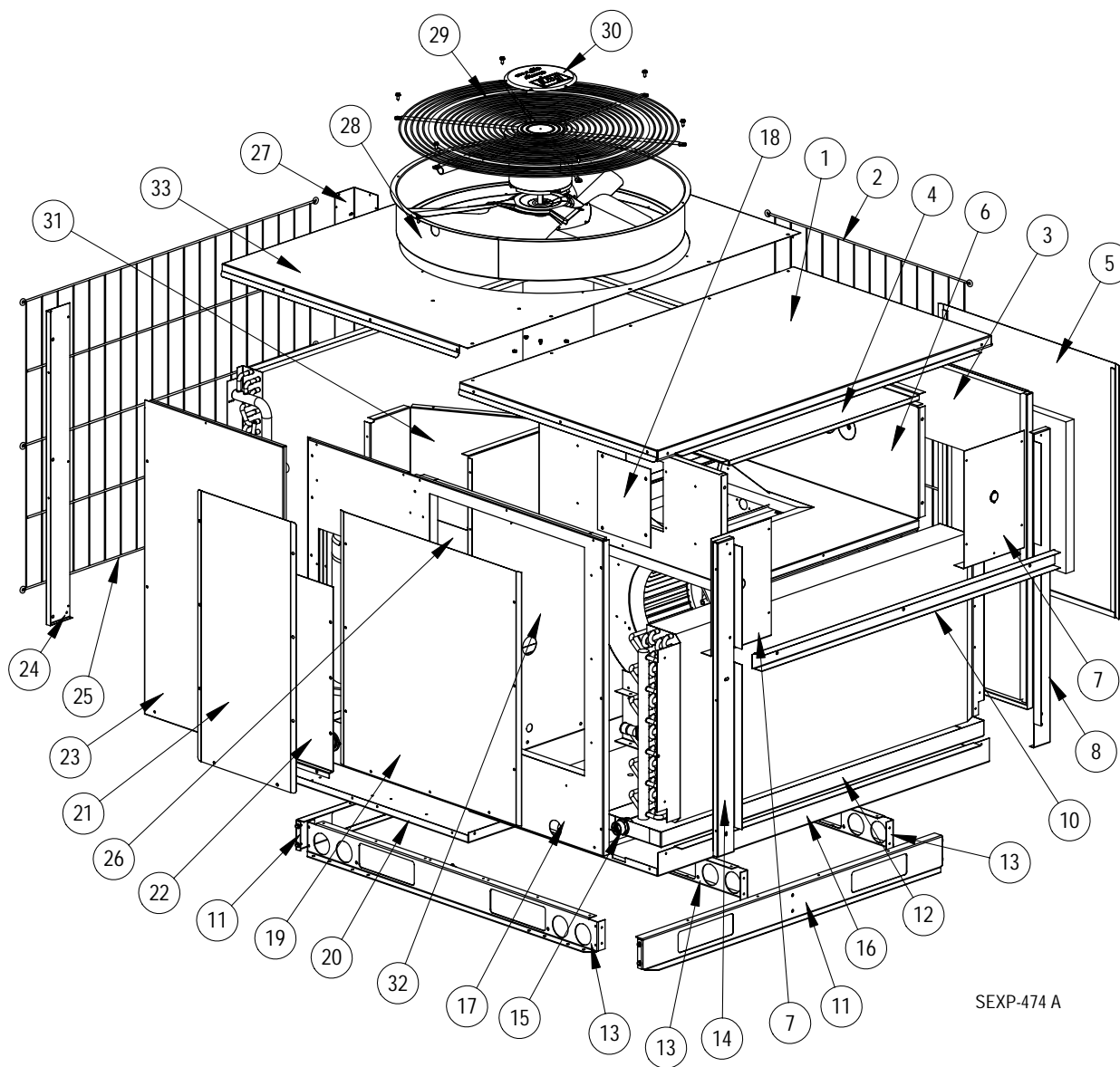

## CABINET COMPONENTS — RIGHT HAND

Drawing No.	Part No.	Description	P60RV1-R	P72RV1-S	P72RV1-T
1	507-255-X	Indoor Top	X	X	X
2	7051-054	Side Condenser Grille	X	X	X
3	501-474-X	Left Side	X	X	X
4	134-134	Heat Strip Shield	X	X	X
5	S553-409-X	Blower Access Door	X	X	X
6	521-400	Blower Partition	X	X	X
7	137-513	Blower Partition Side Fill	2	2	2
8	549-106-X	Left Rear Corner	X	X	X
10	165-590-X	Plenum Channel	X	X	X
11	103-474-X	Base Rail	2	2	2
12	S123-114	Drain Pan with Fitting	X	X	X
13	103-475-X	Center Base Rail	3	3	3
14	549-103-X	Right Rear Corner	X	X	X
15	6094-003	Drain Pan Fitting	X	X	X
16	S127-376-X	Indoor Base	X	X	X
17	S501-473-X	Right Side	X	X	
17	S501-512-X	Right Side			X
18	142-045	OKW Cover Plate	X	X	X
19	S553-400-X	Heater Access Door	X	X	X
20	127-398-X	Outdoor Base	X	X	X
21	S153-399-X	Outer Control Panel Door	X	X	X
22	S153-397	Inner Control Panel Door	X	X	X
23	S153-398-X	Compressor Access Door	X	X	X
24	149-104-X	Right Front Corner	X	X	X
25	7051-053	Front Condenser Grille	X	X	X
26	Control Panel Assembly - See Drawing		X	X	X
27	149-105-X	Left Front Corner	X	X	X
28	S167-014-X	Fan Venturi	X	X	X
29	7051-018	Fan and Motor Mount Grille	X	X	X
30	5252-009	Bard Nameplate	X	X	X
31	135X223	Control Panel Rain Shield	X	X	X
32	S521X399	Condenser Partition	X	X	X
33	107-254-X	Outdoor Top	X	X	X

# CABINET COMPONENTS — LEFT HAND

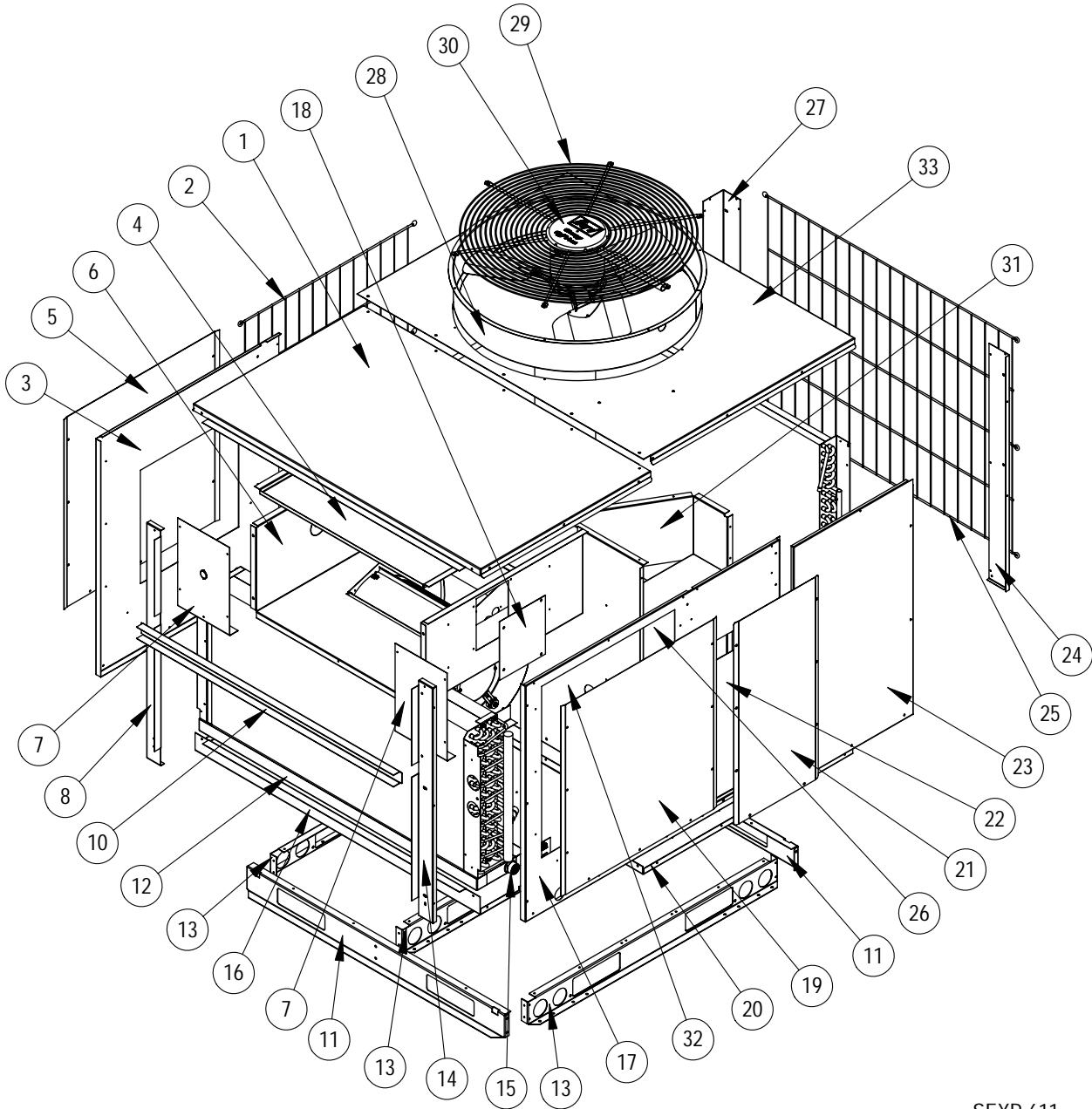

SEXP-611

# CABINET COMPONENTS — LEFT HAND

Drawing No.	Part No.	Description	P60LV1-R	P72LV1-S	P72LV1-T
1	507-255-X	Indoor Top	X	X	X
2	7051-054	Side Condenser Grille	X	X	X
3	501-603-X	Right Side	X	X	X
4	134-134	Heat Strip Shield	X	X	X
5	S553-409-X	Blower Access Door	X	X	X
6	521-450	Blower Partition	X	X	X
7	137-513	Blower Partition Side Fill	2	2	2
8	549-116-X	Left Rear Corner	X	X	X
10	165-590-X	Plenum Channel	X	X	X
11	103-474-X	Base Rail	2	2	2
12	S123-136	Drain Pan with Fitting	X	X	X
13	103-475-X	Center Base Rail	3	3	3
14	549-117-X	Right Rear Corner	X	X	X
15	6094-003	Drain Pan Fitting	X	X	X
16	S127-376-X	Indoor Base	X	X	X
17	S501-602-X	Left Side	X	X	
17	S501-611-X	Left Side			X
18	142-045	OKW Cover Plate	X	X	X
19	S553-400-X	Heater Access Door	X	X	X
20	127-406-X	Outdoor Base	X	X	X
21	S153-399-X	Outer Control Panel Door	X	X	X
22	S153-397	Inner Control Panel Door	X	X	X
23	S153-482-X	Compressor Access Door	X	X	X
24	149-114-X	Left Front Corner	X	X	X
25	7051-053	Front Condenser Grille	X	X	X
26	Control Panel Assembly - See Drawing		X	X	X
27	149-115-X	Right Front Corner	X	X	X
28	S167-014-X	Fan Venturi	X	X	X
29	7051-018	Fan and Motor Mount Grille	X	X	X
30	5252-009	Bard Nameplate	X	X	X
31	135Y223	Control Panel Rain Shield	X	X	X
32	S521Y399	Condenser Partition	X	X	X
33	107-287-X	Outdoor Top	X	X	X

# FUNCTIONAL COMPONENTS — Right Hand (shown), Left Hand Mirrored

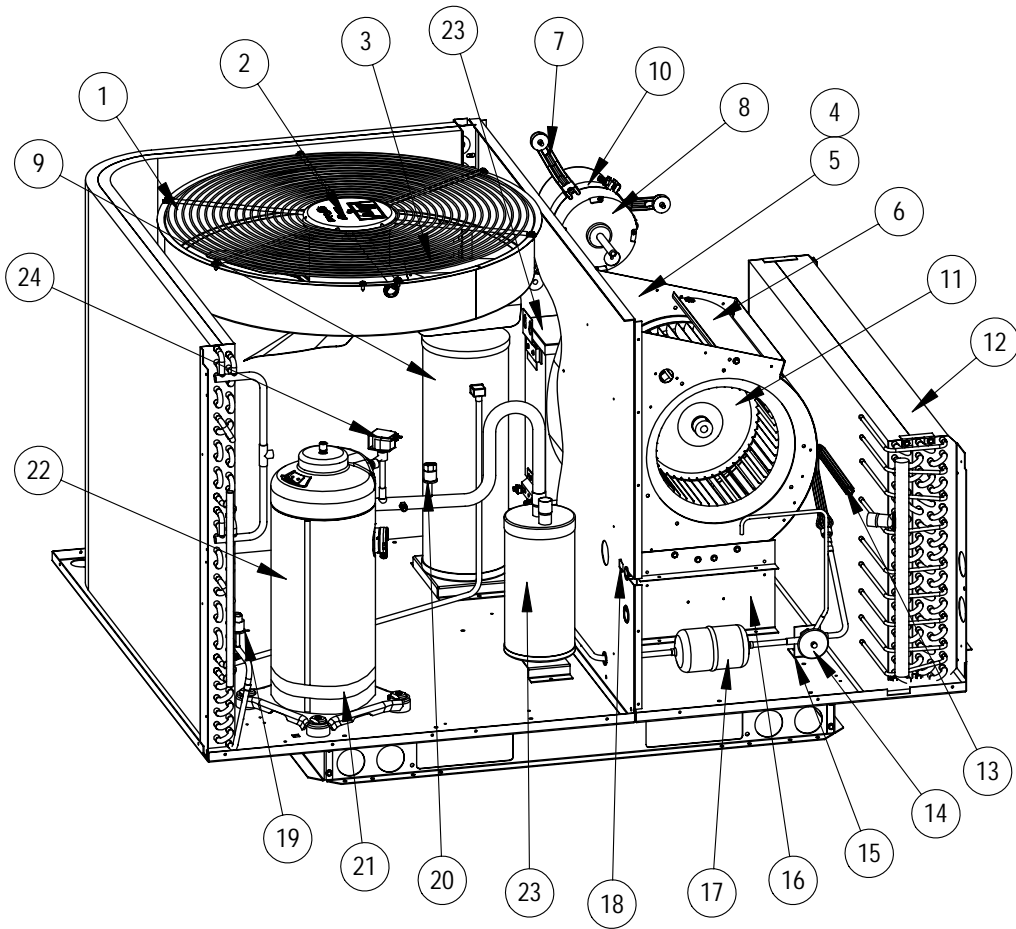

SEXP-612

## FUNCTIONAL COMPONENTS — Right & Left Hand

Drawing No.	Part No.	Description	P60RV1-R	P72RV1-S	P72RV1-T
			P60LV1-R	P72LV1-S	P72LV1-T
1	5051-138BX	Condenser Coil	X	X	X
2	S8106-050-0094	Outdoor Motor	X	X	X
3	5151-057	Fan Blade	X	X	X
4	900-317-001	Complete Blower Assembly	X	X	X
5	151-097	Blower Housing	X	X	X
6	144-130	Diffuser	X	X	X
7	8620-034	Motor Mount Kit	X	X	X
8	S8107-009-0093	Programmed 3/4 HP Motor w/Control	X	X	X
9	5203-006	Receiver	X	X	X
10	8620-034	Motor Mount Kit	X	X	X
11	5152-049	Blower Wheel	X	X	X
12	5060-128BX	Evaporator Coil	X		
12	917-0111BX	Evaporator Coil		X	X
13	800-0413	Cooling Distributor	X		
13	800-0288	Cooling Distributor		X	X
14	5651-215	Expansion Valve	X		
14	5651-213	Expansion Valve		X	X
15	113-422	Cooling TXV Mounting Bracket	X	X	X
16	104-795	Blower Leg	2	2	2
17	5201-002	Filter Drier	X	X	X
18	3000-1357	6 Pin Plug for Heater Package	X	X	X
19	1804-0385	High Pressure Switch	X	X	X
20	1804-0107	Low Pressure Switch	X	X	X
21	8605-017	Crankcase Heater	X		
21	8605-018	Crankcase Heater		X	X
22	8000-352	Compressor	X		
22	8000-358	Compressor		X	
22	8000-359	Compressor			X
23	5202-018	Accumulator	X	X	X
24	5650-049	Solenoid Valve with Coil	X	X	X
NS	8407-004	Step Down Transformer 480/240			X
NS	8406-128	Pressure Transducer	X	X	X

*Reference SEXP-612*

# CONTROL PANEL -R (1-PHASE) Right Hand (shown), Left Hand Mirrored

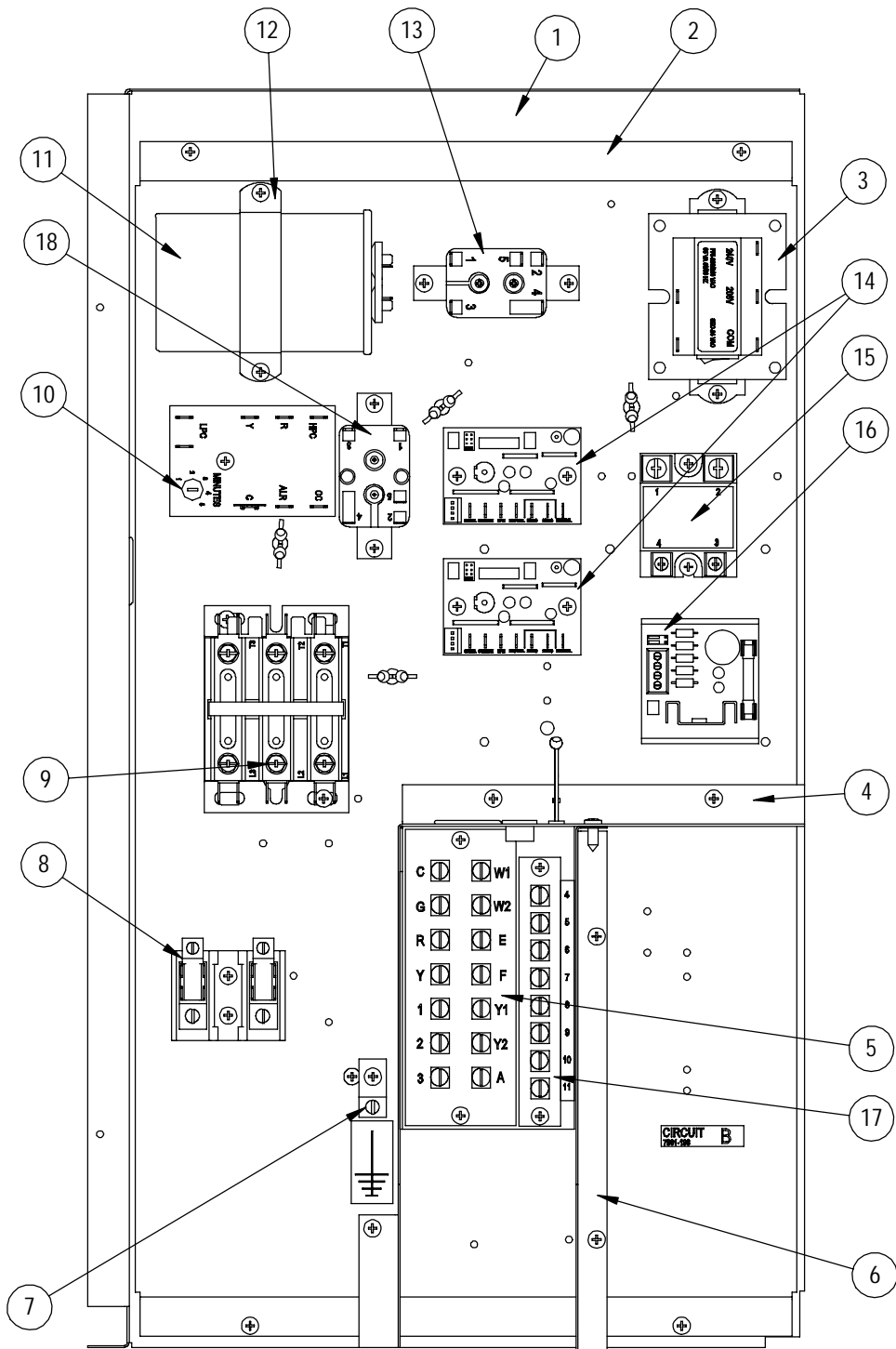

SEXP-607



# CONTROL PANEL -R (1-PHASE) Right Hand (shown), Left Hand Mirrored

Drawing No.	Part No.	Description	P60RV1-R	P60LV1-R
1	117X262	Control Panel - Right Hand	X	
1	117Y262	Control Panel - Left Hand		X
2	117X261	Control Mounting Plate - Right Hand	X	
2	117Y261	Control Mounting Plate - Left Hand		X
3	8407-048	Transformer	X	X
4	117X308	Low Voltage Box Assembly - Right Hand	X	
4	117Y308	Low Voltage Box Assembly - Left Hand		X
5	8607-024	Terminal Strip	X	X
6	135-218	Terminal Shield	X	X
7	8611-006	Ground Terminal	X	X
8	8607-013	Terminal Block	X	X
9	8401-025	Contacto	X	X
10	8201-088	Compressor Control Module	X	X
11	8552-092	Capacitor 100 MFD 370V	X	X
12	8550-008	Capacitor Bracket	X	X
13	8201-062	Relay	X	X
14	8201-124	Blower Control Board	2	2
15	8201-123	Solid State Relay	X	X
16	8301-041	5VDC Power Supply	X	X
17	8607-021	Terminal Strip	X	X
18	8201-009	Relay	X	X
NS	8301-014	Discharge Air Sensor	X	X
NS	4109A114	Wiring Diagram	X	X

NS = Not Shown

Reference SEXP-607

# CONTROL PANEL -S (3-PHASE) Right Hand (shown), Left Hand Mirrored

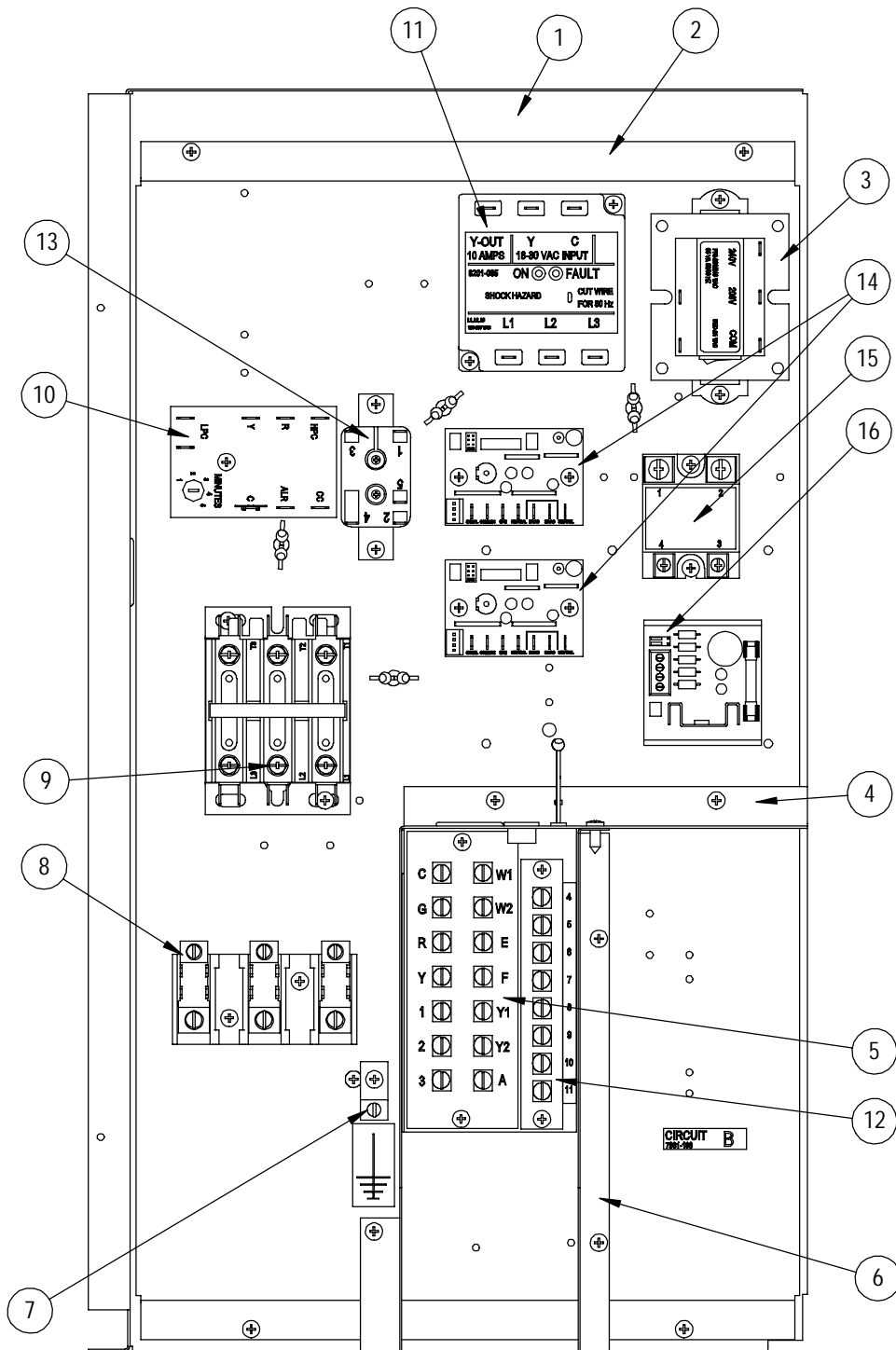

SEXP-608

# CONTROL PANEL -S (3-PHASE) Right Hand (shown), Left Hand Mirrored

Drawing No.	Part No.	Description	P72RV1-S	P72LV1-S
1	117X262	Control Panel - Right Hand	X	
1	117Y262	Control Panel - Left Hand		X
2	117X261	Control Mounting Plate - Right Hand	X	
2	117Y261	Control Mounting Plate - Left Hand		X
3	8407-048	Transformer	X	X
4	117X308	Low Voltage Box Assembly - Right Hand	X	
4	117Y308	Low Voltage Box Assembly - Left Hand		X
5	8607-024	Terminal Strip	X	X
6	135-218	Terminal Shield	X	X
7	8611-006	Ground Terminal	X	X
8	8607-014	Terminal Block	X	X
9	8401-027	Contactorm	X	X
10	8201-088	Compressor Control Module	X	X
11	8201-126	3-Phase Line Monitor	X	X
12	8607-021	Terminal Strip	X	X
13	8201-062	Relay	X	X
14	8201-124	Blower Control Board	2	2
15	8201-123	Solid State Relay	X	X
16	8301-041	5VDC Power Supply	X	X
NS	8301-014	Discharge Air Sensor	X	X
NS	4109A212	Wiring Diagram	X	X

NS = Not Shown

Reference SEXP-608

# CONTROL PANEL -T (3-PHASE) Right Hand (shown), Left Hand Mirrored

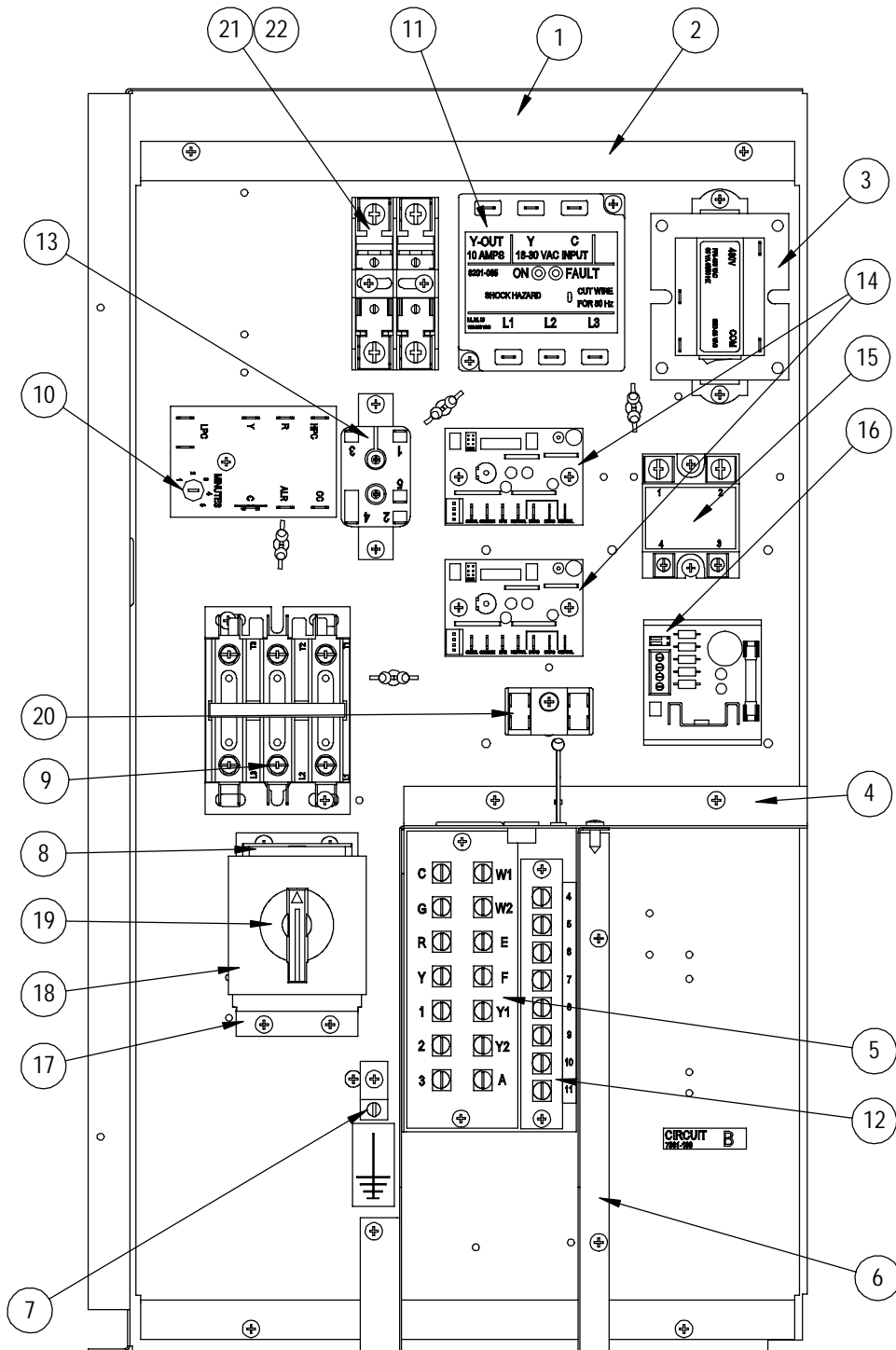

SEXP-609

# CONTROL PANEL -T (3-PHASE) Right Hand (shown), Left Hand Mirrored

Drawing No.	Part No.	Description	P72RV1-T	P72LV1-T
1	117X262	Control Panel - Right Hand	X	
1	117Y262	Control Panel - Left Hand		X
2	117X261	Control Mounting Plate - Right Hand	X	
2	117Y261	Control Mounting Plate - Left Hand		X
3	8407-050	Transformer	X	X
4	117X308	Low Voltage Box Assembly - Right Hand	X	
4	117Y308	Low Voltage Box Assembly - Left Hand		X
5	8607-024	Terminal Strip	X	X
6	135-218	Terminal Shield	X	X
7	8611-006	Ground Terminal	X	X
8	8615-073	Rotary Disconnect	X	X
9	8401-027	Contactors	X	X
10	8201-088	Compressor Control Module	X	X
11	8201-126	3-Phase Line Monitor	X	X
12	8607-021	Terminal Strip	X	X
13	8201-062	Relay	X	X
14	8201-124	Blower Control Board	2	2
15	8201-123	Solid State Relay	X	X
16	8301-041	5VDC Power Supply	X	X
17	127-365	Disconnect Mounting Base	X	X
18	134-247	Wire Shield	X	X
19	8615-071	Disconnect Handle	X	X
20	8607-017	Terminal Block	X	X
21	8614-041	Fuse Block	X	X
22	8614-046	5A Class CC Fuse	2	2
NS	8301-014	Discharge Air Sensor	X	X
NS	4109A305	Wiring Diagram	X	X

NS = Not Shown

Reference SEXP-609