

# REPLACEMENT PARTS MANUAL

## PACKAGE HEAT PUMP

MODEL: PH1124, PH1130, PH1136

Manual 2110-255

Revision C

Date 4-20-94

Supersedes 7-20-93

\*\*\*\*\*  
\* GENERAL NOTES \*  
\*\*\*\*\*

\*Revised and/or additional pages may be issued from time to time.  
\*A complete and current manual consists of pages dated as shown in the following index.

\*\*\*\*\*  
\*\* INDEX \*\*  
\*\*\*\*\*

<u>Page Description</u>	<u>Page</u>	<u>Date</u>	<u>Supersedes</u>
Cabinet Components--Exploded View	1	3-30-92	
" " --Usage List	2	3-30-92	
Functional Components--Exploded View	3	3-30-92	
" " --Usage List	4	4-20-94	7-20-93
Control Panel--Layout	5	3-30-92	
" " --Usage List	6	3-30-92	
Control Panel--PH1136-D, PH1136-C--Layout	7	4-20-94	
" " --Usage List	8	4-20-94	

\*\*\*\*\*  
\*\*\* IMPORTANT \*\*\*  
\*\*\*\*\*

Contact the installing and/or local Bard distributor for all parts requirements. Make sure you have the complete model and serial number available from the unit rating plate.

BARD MANUFACTURING COMPANY

BRYAN, OHIO 43506

CABINET COMPONENTS

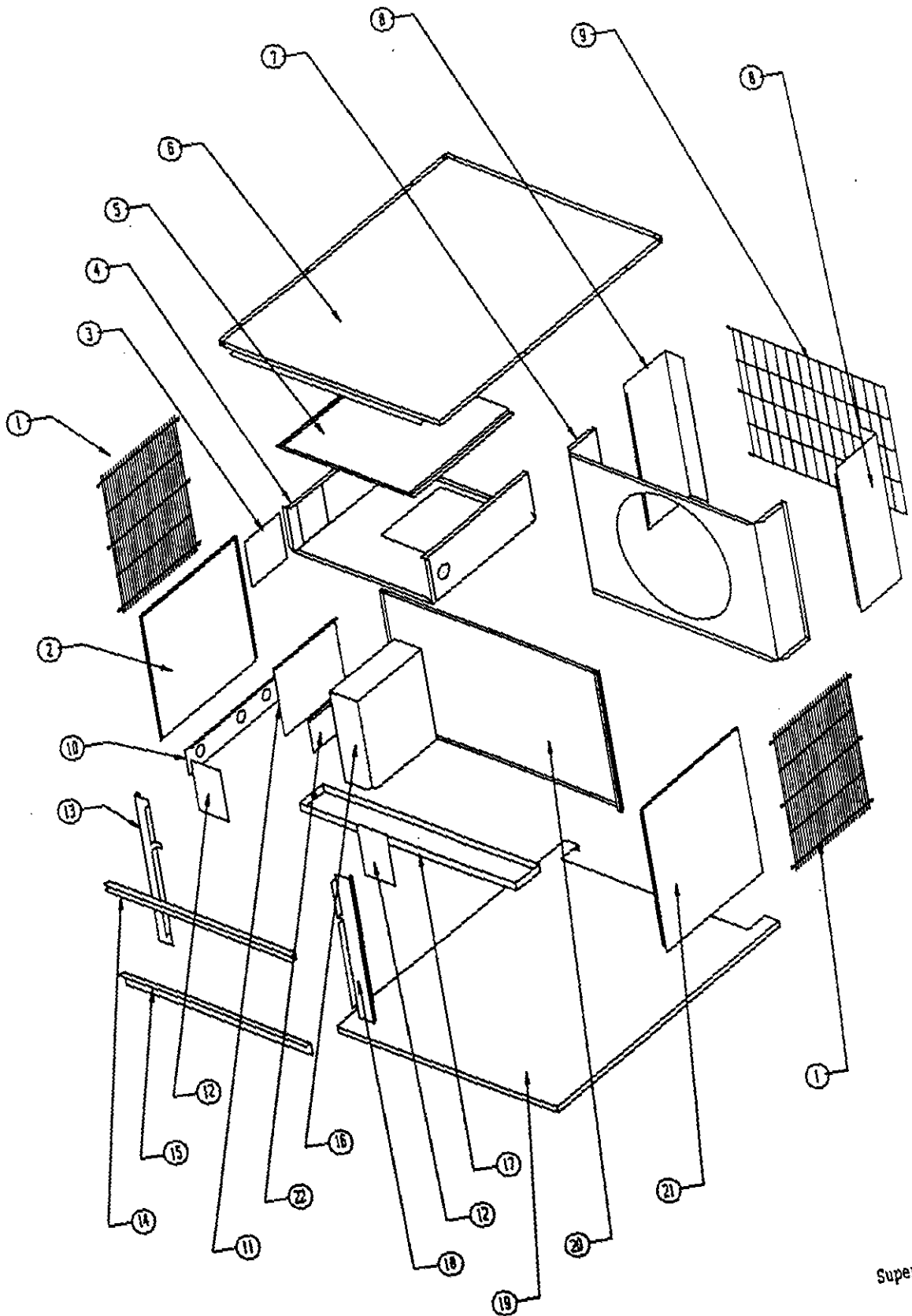

CABINET COMPONENTS

Item	Part No.	Description	U S A G E
1	7051-015	Inlet Grille	2
2	500-133	Left Side	X
3	142-017	Cover Plate--OKW	X
4	520-092	Blower Partition (PH1124 only)	X
4	520-066	Blower Partition (all models except PH1124)	X
5	134-017	Heat Strip Shield	X
6	506-011	Top	X
7	124-012	Fan Shroud (PH1124 only)	X
7	124-002	Fan Shroud (all models except PH1124)	X
8	149-043	Rear Corner	2
9	7051-001	Condenser Grille	X
10	556-018	Entrance Panel	X
11	132-035	Control Panel Cover	X
12	136-086	Blower Fill Plates	2
13	549Y044	Left Front Cover	X
14	164-501	Plenum Channel	X
15	104-521	Plenum Angle	X
16	Cntrl Pnl Asseblly	See Control Panel Drawing and Parts List	X X
17	123-043	Drain Pan	X
18	549X044	Right Front Corner	X
19	527-011	Base	X
20	520-070	Compressor Partition	X
21	500-132	Right Side	X
22	142-016	Entrance Cover	X

Date: 3-30-92  
Supersedes:

FUNCTIONAL COMPONENTS

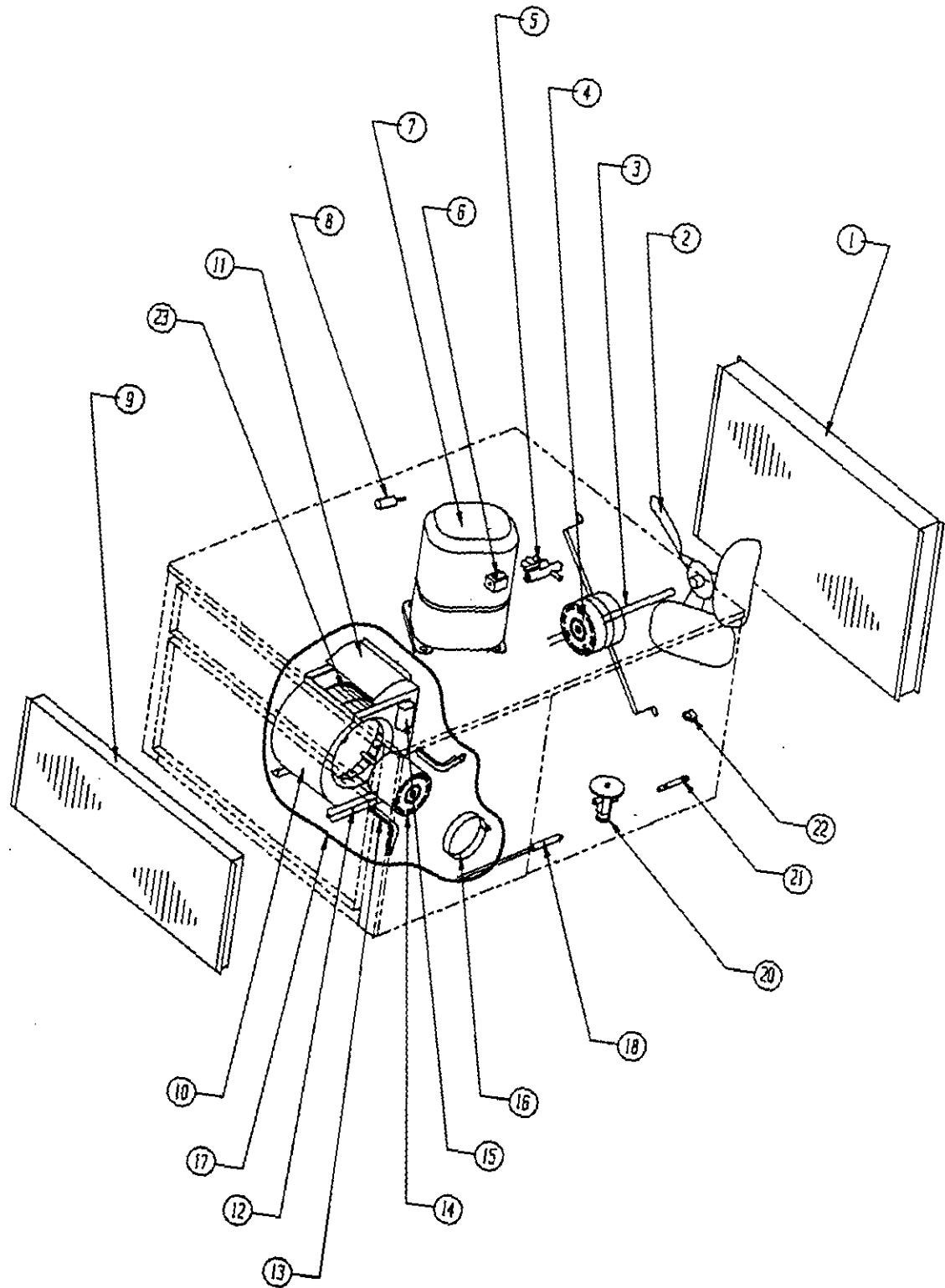

Date: 3-30-92  
Supersedes:

FUNCTIONAL COMPONENTS

Dwg. No.	Part No.	Description	P	P	P	P	P
			H	H	H	H	H
			1	1	1	1	1
			2	3	3	3	3
			4	0	6	6	6
						-	-
						B	C
1	5051-053	Condenser Coil	X				
1	5051-072	Condenser Coil		X	X	X	X
2	5151-034	Fan Blade	X				
2	5151-004	Fan Blade		X	X	X	X
3	8200-001	Motor Mount	X	X	X	X	X
4	8103-014	Motor					X
4	8103-016	Motor	X				
4	8103-019	Motor		X	X	X	
5	5650-020	Reversing Valve	X	X	X	X	X
6	5650-022	Reversing Valve Solenoid	X	X	X	X	X
7	8000-116	Compressor ZR23K1-PFV-230	X				
7	8000-117	Compressor ZR28K1-PFV-230		X			
7	8000-115	Compressor ZR34K1-PFV-230			X		
7	8000-163	Compressor				X	
7	8000-164	Compressor					X
8	8406-040	High Pressure Switch	X	X	X	X	X
9	5060-052	Evaporator Coil	X				
9	5060-068	Evaporator Coil		X	X	X	X
10	151-088	Blower Housing	X				
10	151-068	Blower Housing		X	X	X	X
11	144-156	Blower Diffuser	X				
11	144-126	Blower Diffuser		X	X	X	X
12	104-787	Blower Angle	X	X	X	X	X
13	8200-036	Motor Mount Arm	3				
13	8200-034	Motor Mount Arm		3	3	3	3
14	8105-016	Motor					X
14	8105-032	Motor	X				
14	8105-024	Motor		X	X	X	
15	8552-002	Capacitor 5/370	X	X	X	X	X
16	8200-033	Motor Mount Band	X	X	X	X	X
17	900-146	Complete Blower Assembly	X				
17	900-145	Complete Blower Assembly		X	X	X	
17	900-207	Complete Blower Assembly					X
18	800-0192	Cooling Flow Control Assembly	X				
18	800-0196	Cooling Flow Control Assembly		X			
18	800-0195	Cooling Flow Control Assembly			X	X	X
20	5651-090	Expansion Valve	X	X			
20	5651-091	Expansion Valve			X	X	X
21	5651-036	Check Valve	X	X	X	X	X
22	8408-027	Defrost Sensor	X	X	X	X	X
23	5152-065	Blower Wheel	X				
23	5152-005	Blower Wheel		X	X	X	X

Date: 4-20-94  
Supersedes: 7-20-93

2110-255

CONTROL PANEL

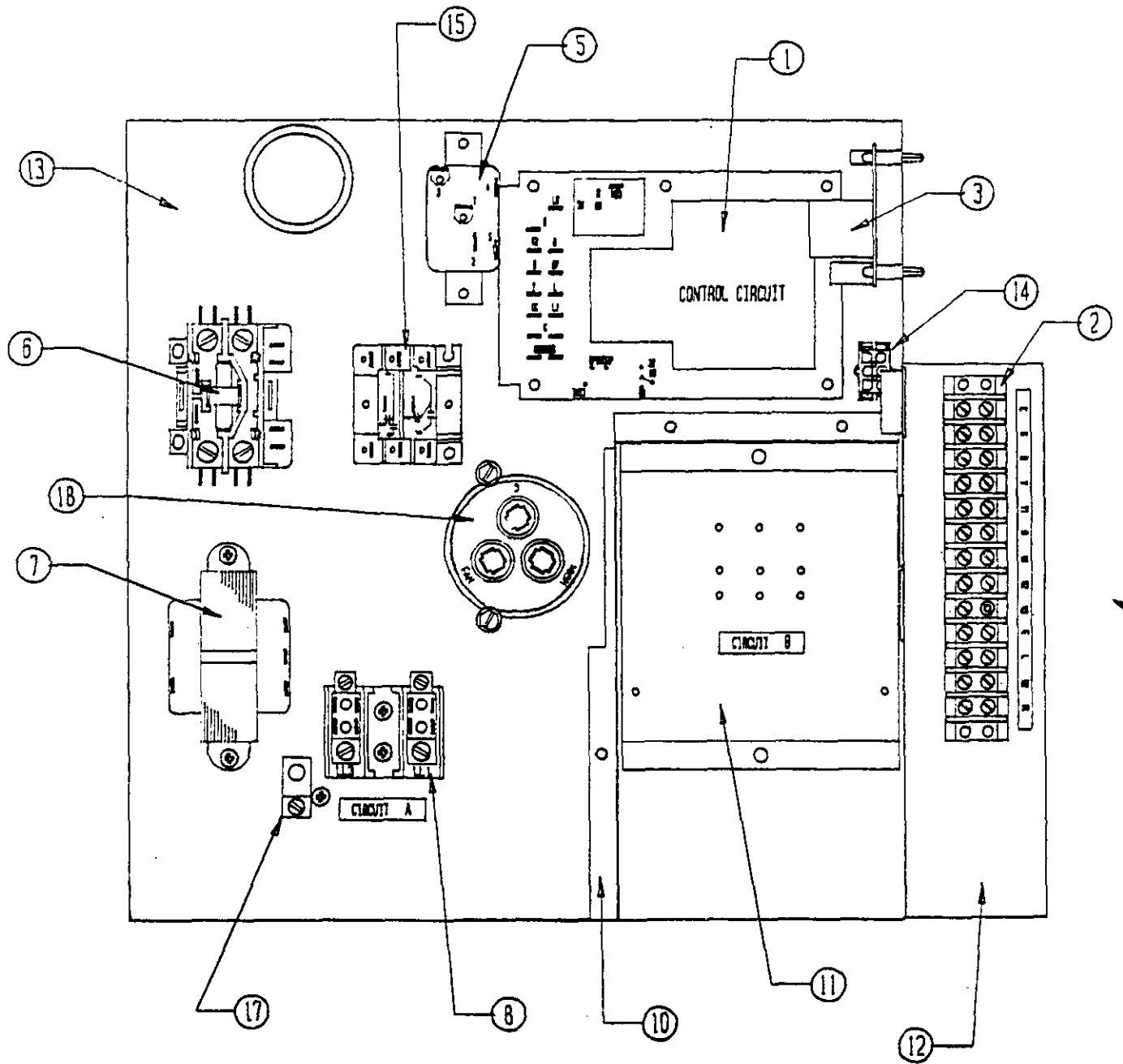

Date: 3-30-92  
Supersedes:

CONTROL PANEL

Dwg. No.	Part No.	Description	P H 1 1 2 4	P H 1 1 3 0	P H 1 1 3 6 - A
1	8201-068	Heat Pump Control	X	X	X
2	8607-010	Terminal Strip	X	X	X
3	8201-056	Blower Control	X	X	X
5	8201-008	Defrost Heat Relay	X	X	X
6	8401-007	Contactora	X	X	X
7	8407-035	Transformer	X	X	X
8	8607-013	Terminal Block	X	X	X
10	116X076	Control Panel Partition	X	X	X
11	134-095	Terminal Block Shield	X	X	X
12	116X072	Low Voltage Box	X	X	X
13	516Y141	Control Panel	X	X	X
14	3000-976	Wire Assembly	X		
14	3000-974	Wire Assembly		X	X
15	8201-013	Em. Heat Relay		X	X
17	8611-006	Ground Terminal	X	X	X
18	8552-047	Capacitor 30/5 - 370	X		
18	8552-048	Capacitor 35/5 - 370		X	
18	8552-049	Capacitor 35/5 - 440			X
	4098-110	Wiring Diagram	X		
	4098-120	Wiring Diagram		X	X

Date: 3-30-92  
Supersedes:

CONTROL PANEL

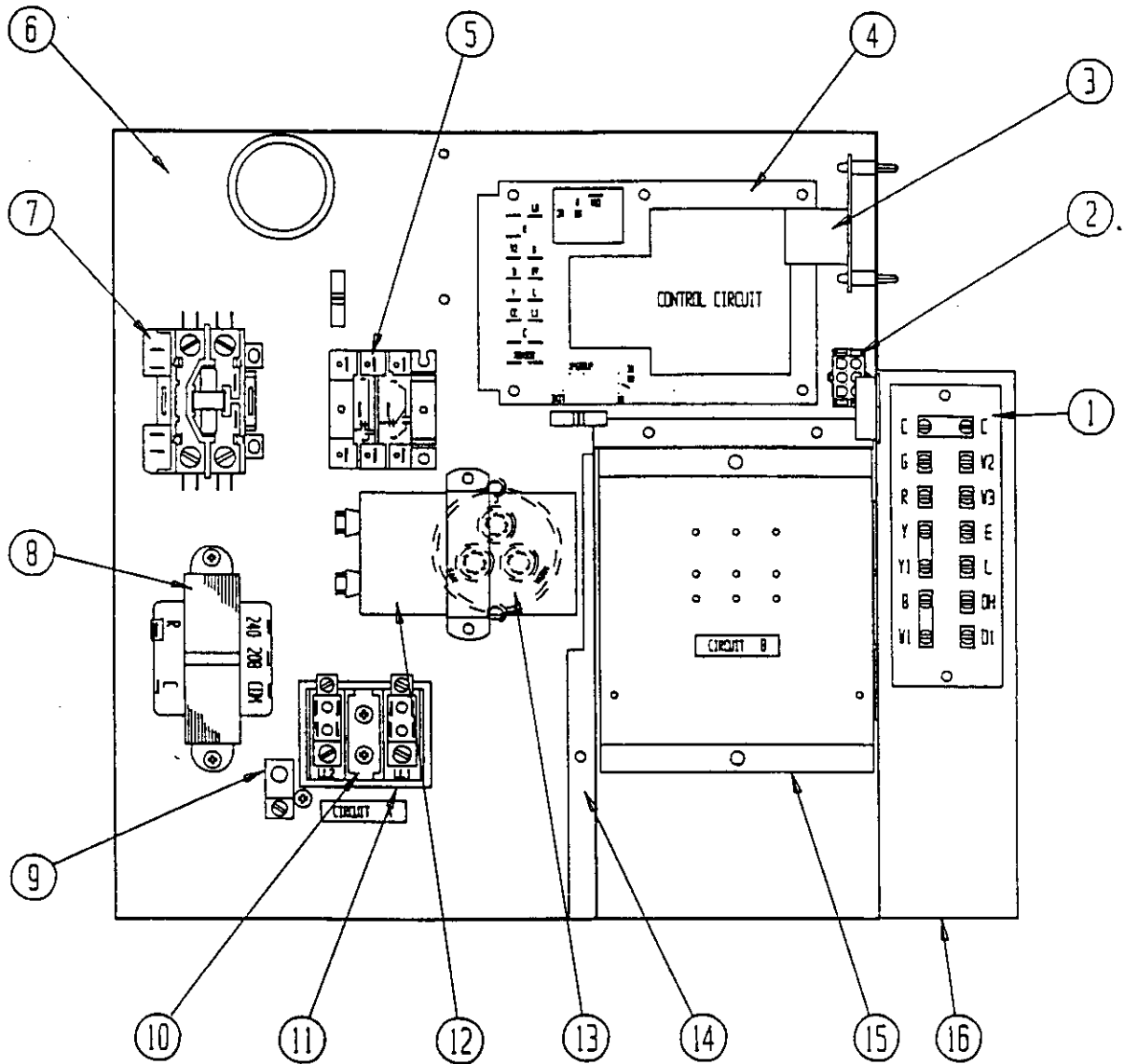

MODELS: PH1136-B and PH1136-C

Date: 4-20-94  
Supersedes:

2110-255  
Page: 7



CONTROL PANEL

Dwg. No.	Part No.	Description	P H 1 1 3 6 - B	P H 1 1 3 6 - C
1	8607-019	Terminal Strip	X	X
2	3000-1000	Wire Assembly	X	X
3	8201-056	Solid State Blower Control	X	
3	8201-032	Blower Relay		X
4	8201-068	Heat Pump Control	X	X
5	8201-013	Changeover Relay	X	X
6	516-147	Control Panel	X	X
7	8401-002	Contactor	X	X
8	8407-035	Transformer	X	
8	8407-042	Transformer		X
9	8611-006	Ground Terminal	X	X
10	8607-014	Terminal Block	X	X
11	8607-015	Phenolic Insulator		X
12	8552-002	Capacitor 5-370	X	X
14	116-149	Control Panel Partition	X	X
15	116-150	Terminal Block Support	X	X
16	116-148	Low Voltage Box	X	X
	4065-211	Wiring Diagram	X	
	4065-311	Wiring Diagram		X

Date: 4-20-94  
Supersedes:

