

---

# REPLACEMENT PARTS MANUAL

# WALL MOUNTED PACKAGE AIR CONDITIONER

MODELS: WA301, WA361

---

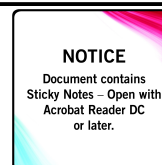

## General Notes

- Revised and/or additional pages may be issued from time to time.
- A complete and current manual consists of pages shown in the following contents section.

## Important

- Contact the installing and/or local Bard distributor for all parts requirements. Make sure you have the complete model and serial number available from the unit rating plates.

## Contents

Description	Page
Cabinet Components	
◆ Exploded View .....	1
◆ Usage List .....	2
◆ Usage List .....	3
◆ Blank Page .....	4
Functional Components	
◆ Exploded View .....	5
◆ Usage List .....	6
◆ Usage List .....	7
◆ Blank Page .....	8
Control Panel	
◆ Exploded View .....	9
◆ Usage List .....	10
◆ Exploded View .....	11
◆ Usage List .....	12
Blower Assembly	
◆ Exploded View .....	13
◆ Usage List .....	13



**BARD MANUFACTURING COMPANY**  
Bryan, Ohio 43506

*Since 1914...Moving ahead, just as planned.*

Manual: 2110-409 L  
Supersedes: 2110-409 K  
File: 2150-004, Tab 16  
Date: 10-05-99

---

# CABINET COMPONENTS

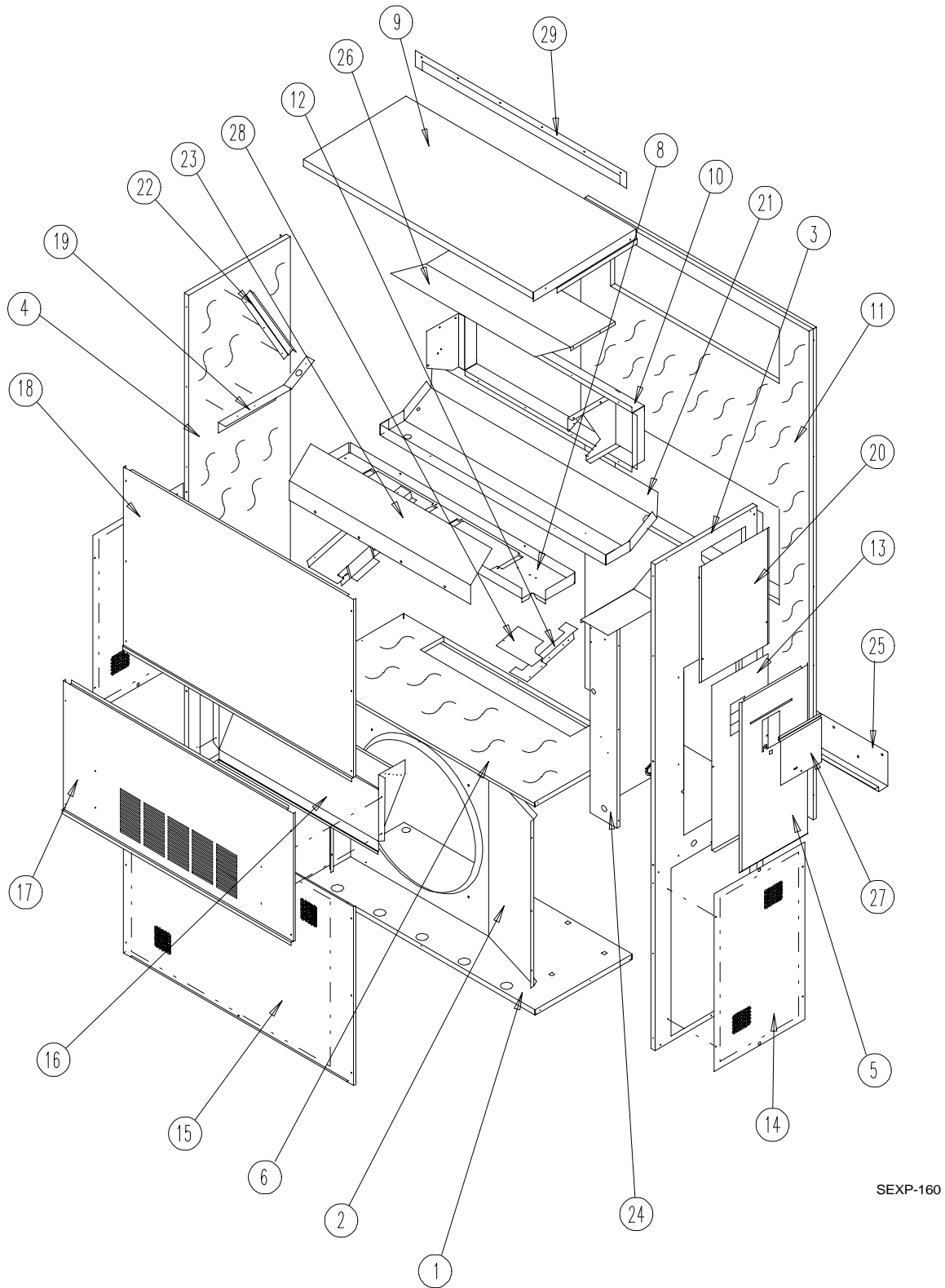

SEXP-160

**This Drawing is referenced on Pages 2 and 3**

# CABINET COMPONENTS

Drawing No.	Part No.	Description	WA301-A,B,D	WA301-C	WA301-F	WA361-A,B,D,E	WA361-C	WA361-F	WA361HA,B	WA361HC	WA361HF
1	S127-199	Lower Base	X	X	X	X	X	X	X	X	X
2	125-022	Fan Shroud	X	X	X	X	X	X	X	X	X
3	S500-228-* ①	Right Side	X	X	X	X	X	X	X	X	X
4	S500-229-* ①	Left Side	X	X	X	X	X	X	X	X	X
5	S533-109-* ①	Control Panel Cover (Outer)	X	X	X	X	X	X	X	X	X
6	S520X181	Condenser Partition	X	X	X	X	X	X	X	X	X
8	121X182	Blower Partition	X	X	X	X	X	X	X	X	X
9	S506-130-* ①	Top	X	X	X	X	X	X	X	X	X
10	S111X030	Outlet Airframe Assembly	X	X	X	X	X	X	X	X	X
11	S508-088	Back	X	X	X	X	X	X	X	X	X
12	113X195	Filter Bracket	2	2	2	2	2	2	2	2	2
13	S132-104	Control Panel Cover (Inner)	X			X			X		
13	S132-110	Control Panel Cover (Inner)		X	X		X	X		X	X
14	118-028-* ①	Side Grille	2	2	2	2	2	2	2	2	
15	118-029-* ①	Condenser Grille	X	X	X	X	X	X	X	X	X
16	BFAD-3	Fresh Air Damper Assembly	X	X	X	X	X	X	X	X	X
17	S552-206-* ①	Service Door	X	X	X	X	X	X	X	X	X
18	S514-072-* ①	Upper Front	X	X	X	X	X	X	X	X	X
19	105X850	Left Side Support	X	X	X	X	X	X	X	X	X
20	S143-034-*①	Right Side Cover Plate (Outer)	X	X	X	X	X	X	X	X	X
21	S123-078	Drain Pan	X	X	X	X	X	X	X	X	X
22	147-044-*	Evaporator Support	X	X	X	X	X	X	X	X	X
23	135-124	Air Baffle X	X	X	X	X	X	X	X	X	
24	Control Panel Assembly	See Control Panel Assembly Drawing and Parts List	X	X	X	X	X	X	X	X	X
25	113-140	Bottom Mounting Bracket	1	1	1	1	1	1	1	1	1
26	135X123	Heat Shield	X	X	X	X	X	X	X	X	X
27	S153-218-* ①	Disconnect Access Door	X	X	X	X	X	X	X	X	X
28	137-259	Fill Plate	X	X	X	X	X		X	X	
28	136-212	Fill Plate							X	X	
29	113-149-* ①	Top Rain Flashing	X	X	X	X	X	X	X	X	X

① NOTE: Exterior cabinet parts are manufactured with various paint color options. To insure that you receive the proper paint color, you must include the complete model and serial number of the unit for which cabinet parts are being ordered.

This Table references Exploded View on Page 1

# CABINET COMPONENTS

Drawing			WA301DA, DB	WA301DC	WA361DA, DB	WA361DC
No.	Part No.	Description				
1	S127-199	Lower Base	X	X	X	X
2	125-022	Fan Shroud	X	X	X	X
3	S500-228-* ①	Right Side	X	X	X	X
4	S500-229-* ①	Left Side	X	X	X	X
5	S533-109-* ①	Control Panel Cover (Outer)	X	X	X	X
6	S520X181	Condenser Partition	X	X	X	X
8	121X182	Blower Partition	X	X	X	X
9	S506-130-* ①	Top	X	X	X	X
10	S111X030	Outlet Airframe Assembly	X	X	X	X
11	S508-088	Back	X	X	X	X
12	113X195	Filter Bracket	2	2	2	2
13	S132-104	Control Panel Cover (Inner)	X		X	
13	S132-110	Control Panel Cover (Inner)		X		X
14	118-028-* ①	Side Grille	2	2	2	2
15	118-029-* ①	Condenser Grille	X	X	X	X
16	962014	Fresh Air Damper Assembly	X	X	X	X
17	S552-206-* ①	Service Door	X	X	X	X
18	S514-072-* ①	Upper Front	X	X	X	X
19	105X850	Left Side Support	X	X	X	X
20	S143-034-* ①	Right Side Cover Plate (Outer)	X	X	X	X
21	S123-078	Drain Pan	X	X	X	X
22	147-044-*	Evaporator Support	X	X	X	X
23	135-124	Air Baffle	X	X	X	X
24	Control Panel Assembly	See Control Panel Assembly Drawing and Parts List	X	X	X	X
25	113-140	Bottom Mounting Bracket	1	1	1	1
26	135X123	Heat Shield	X	X	X	X
27	S153-218-* ①	Disconnect Access Door	X	X	X	X
29	113-149-* ①	Top Rain Flashing	X	X	X	X

① NOTE: Exterior cabinet parts are manufactured with various paint color options. To insure that you receive the proper paint color, you must include the complete model and serial number of the unit for which cabinet parts are being ordered.

This Table references Exploded View on Page 1

**This page has been  
left blank intentionally.**

**FUNCTIONAL COMPONENTS**

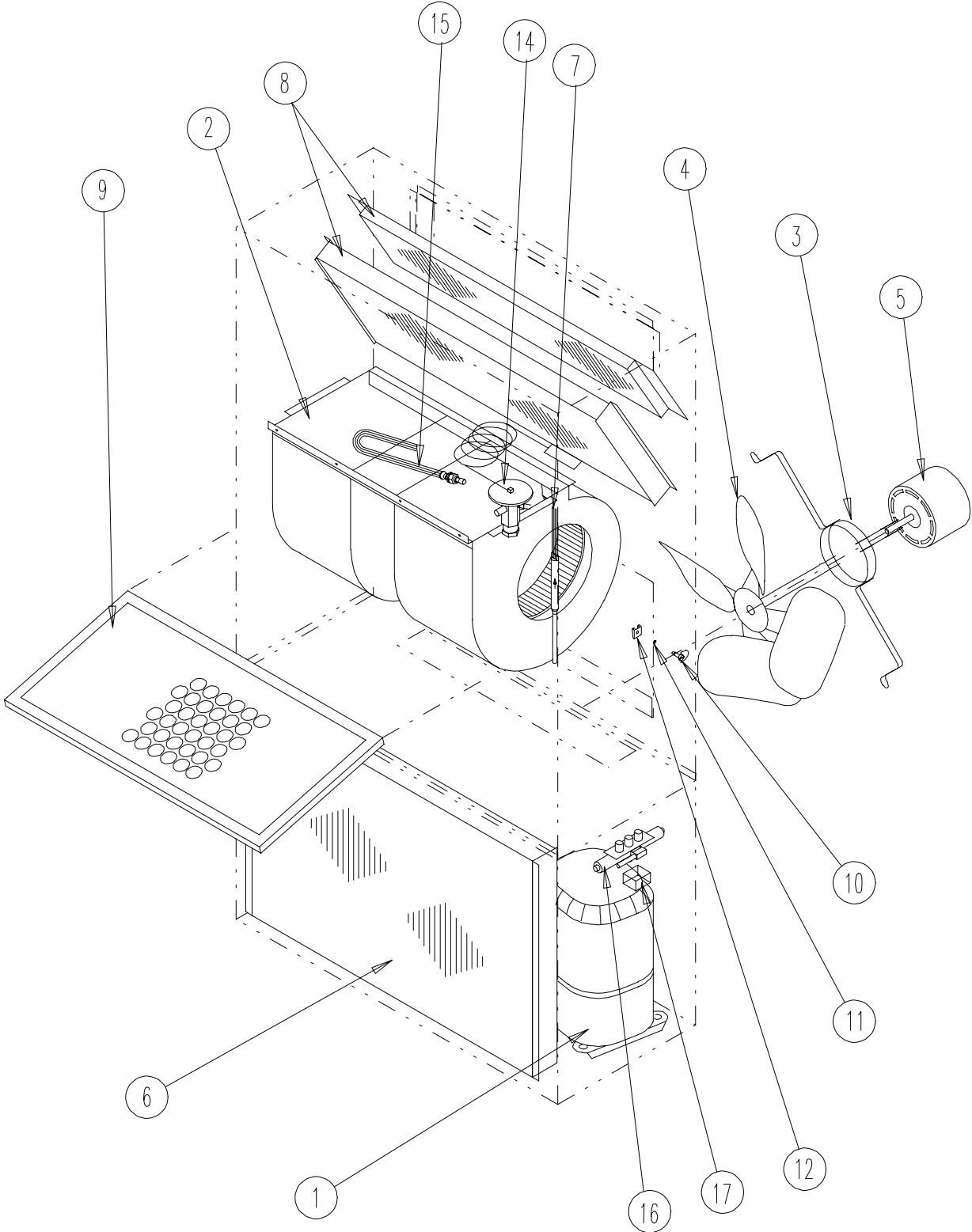

SEXP-162

**This Drawing is referenced on Pages 6 and 7**

# FUNCTIONAL COMPONENTS

Drawing			WA301-A	WA301-B	WA301-C	WA301-D	WA301-F	WA361-A	WA361-B	WA361-C	WA361-D	WA361-E	WA361-F	WA361HA	WA361HB	WA361HC	WA361HF
No.	Part No.	Description															
1	8000-125	Compressor						X						X			
1	8000-132	Compressor	X														
1	8000-133	Compressor							X			X			X		
1	8000-134	Compressor								X						X	X
1	8000-135	Compressor		X													
1	8000-136	Compressor			X		X										
1	8000-144	Compressor				X											
1	8000-145	Compressor									X						
2	S900-179	Blower Assembly	X	X		X	X	X	X		X	X	X	X	X		X
2	S900-180	Blower Assembly			X					X						X	
3	8200-001	Fan Motor Mount	X	X	X	X	X	X	X	X	X	X	X	X	X	X	X
4	5151-045	Fan Blade	X	X	X	X	X	X	X	X	X	X	X	X	X	X	X
5	8103-013	Condenser Motor	X	X		X	X	X	X		X	X	X	X	X		X
5	8103-020	Condenser Motor			X					X						X	
6	5051-066	Condenser Coil					X	X	X	X	X	X	X	X	X	X	X
6	5051-068	Condenser Coil	X	X	X	X	X	X	X	X	X	X	X				
7	800-0185	Cooling Capillary Assy.					X	X	X	X	X	X	X				
7	800-0184	Cooling Capillary Assy.	X	X	X	X	X	X	X	X	X	X	X				
8	5060-064	Evaporator Coil	X	X	X	X	X	X	X	X	X	X	X	X	X	X	X
9	7004-019	Air Filter 1" Throw-Away	X	X	X	X	X	X	X	X	X	X	X	X	X	X	X
9	7003-031	Air Filter 1" Washable ①	X	X	X	X	X	X	X	X	X	X	X	X	X	X	X
9	7004-026	Air Filter 2" Pleated ①	X	X	X	X	X	X	X	X	X	X	X	X	X	X	X
10	1171-022	1/4" Turn Fastener	X	X	X	X	X	X	X	X	X	X	X	X	X	X	X
11	1171-024	1/4" Turn Retainer	X	X	X	X	X	X	X	X	X	X	X	X	X	X	X
12	1171-023	1/4" Receptacle	X	X	X	X	X	X	X	X	X	X	X	X	X	X	X
NS	1804-0106	High Pressure Switch (Flr) ①	X	X	X	X	X	X	X	X	X	X	X	X	X	X	X
NS	1804-0107	Low Pressure Switch (Flr) ①	X	X	X	X	X	X	X	X	X	X	X	X	X	X	X
NS	CMA-6	Low Ambient Control (Flr) ①	X	X	X	X	X	X	X	X	X	X	X				
NS	5201-001	Filter Dryer												X	X	X	X
NS	5201-014	Sight Glass												X	X	X	X
NS	5202-016	Accumulator												X	X	X	X
NS	5203-004	Receiver												X	X	X	X
NS	5651-051	Shut-Off Valve												X	X	X	X
NS	5651-096	Hot Gas Bypass Valve												X	X	X	X
NS	5651-097	Head Pres. Contr. Valve												X	X	X	X
NS	5651-098	Distributor												X	X	X	X
NS	5651-100	TXV												X	X	X	X

NS – Not Shown

① – Optional

**This Table references Exploded View on Page 5**

# FUNCTIONAL COMPONENTS

Drawing No.	Part No.	Description	WA301DA	WA301DB	WA301DC	WA361DA	WA361DB	WA361DC
1	8000-125	Compressor				X		
1	8000-132	Compressor	X					
1	8000-133	Compressor					X	
1	8000-134	Compressor						X
1	8000-135	Compressor		X				
1	8000-136	Compressor			X			
2	S900-179	Blower Assembly	X	X		X	X	
2	S900-180	Blower Assembly			X			X
3	8200-001	Fan Motor Mount	X	X	X	X	X	X
4	5151-045	Fan Blade	X	X	X	X	X	X
5	8103-013	Condenser Motor	X	X		X	X	
5	8103-020	Condenser Motor			X			X
6	5051-066	Condenser Coil	X	X	X	X	X	X
8	917-0033	Evaporator Coil	X	X	X	X	X	X
9	7004-019	Air Filter 1" Throw-Away	X	X	X	X	X	X
9	7003-031	Air Filter 1" Washable ①	X	X	X	X	X	X
9	7004-026	Air Filter 2" Pleated ①	X	X	X	X	X	X
10	1171-022	1/4" Turn Fastener	X	X	X	X	X	X
11	1171-024	1/4" Turn Retainer	X	X	X	X	X	X
12	1171-023	1/4" Receptacle	X	X	X	X	X	X
14	5651-071	TXV	X	X	X	X	X	X
15	5625-015	Distributor	X	X	X	X	X	X
16	5650-026	Three-Way Valve	X	X	X	X	X	X
17	5650-027	Solenoid	X	X	X	X	X	X
NS	1804-0106	High Pressure Switch (Flr) ①	X	X	X	X	X	X

NS – Not Shown

① – Optional

This Table references Exploded View on Page 5



**This page has been  
left blank intentionally.**

# CONTROL PANEL

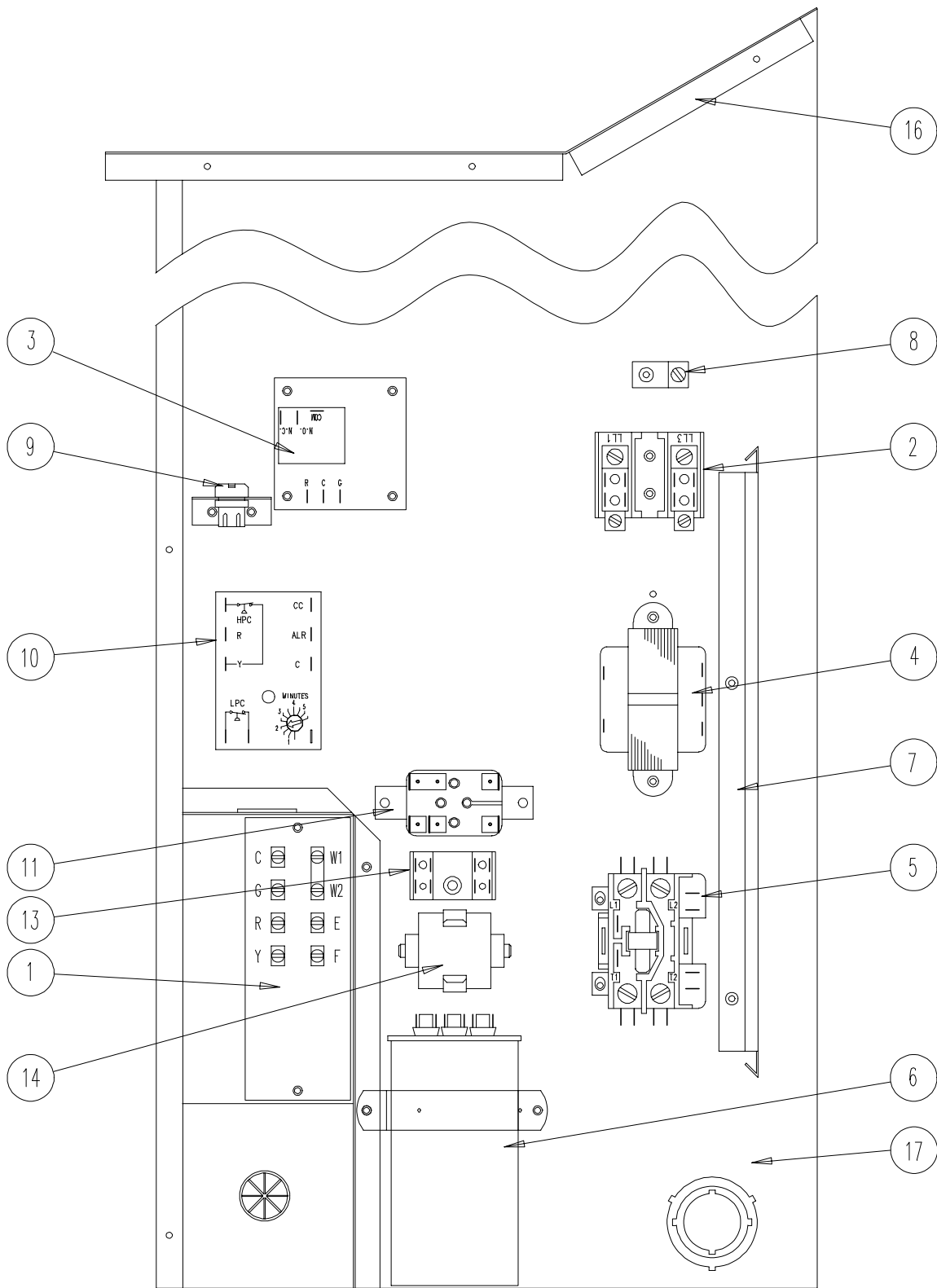

SEXP-163

# CONTROL PANEL

Drawing No.	Part No.	Description	WA301-A	WA301-B	WA301-C	WA301-D	WA301-F	WA361-A, WA361HA	WA361-B, WA361HB	WA361-C, WA361HC	WA361-D	WA361-E	WA361-F, WA361HF
1	8607-020	Low Voltage Terminal Strip	X	X	X	X	X	X	X	X	X	X	X
2	8607-013	Terminal Block 2 Pole	X			X	2	X			X		2
2	8607-014	Terminal Block 3 Pole		X	X				X	X		X	
2	8607-015	Phenolic Insulator			X		2			X			2
3	8201-056	Blower Control	X	X		X	X	X	X		X	X	X
3	8201-032	Blower Relay			X					X			
4	8407-034	Transformer	X	X		X	X	X	X		X	X	X
4	8407-042	Transformer			X					X			
5	8401-007	Compressor Contactor	X			X		X			X		
5	8401-002	Compressor Contactor		X	X		X		X	X	X	X	X
6	8552-048	Compressor Capacitor	X			X							
6	8552-050	Compressor Capacitor						X			X		
6	8552-002	Outdoor Motor Capacitor		X	X		X		X	X		X	X
7	135-122	Wire Shield	X	X	X	X	X	X	X	X	X	X	X
8	8611-006	Ground Terminal	X	X	X	X	X	X	X	X	X	X	X
9	3000-968	6 Pin Connector	X	X	X	X	X	X	X	X	X	X	X
10	8201-088	Compressor Control Module(Optional)	X	X	X	X	X	X	X	X	X	X	X
11	8201-062	Alarm Relay (Optional)	X	X	X	X	X	X	X	X	X	X	X
12	8201-050	Compressor TDR (Optional)	X	X	X	X	X	X	X	X	X	X	X
13	8607-017	Terminal Block (Optional)	X	X	X	X	X	X	X	X	X	X	X
14	8551-005	Start Device (PTCR) (Optional)	X			X		X			X		
16	117-137	Control Panel Top	X	X	X	X	X	X	X	X	X	X	X
17	117-123	Control Panel	X	X	X	X	X	X	X	X	X	X	X
NS	8615-038	Circuit Breaker 35 A 2 Pole (Opt) ①		X			X		X			X	
NS	8615-054	Circuit Breaker 20 A 2 Pole (Opt) ①		X									
NS	8615-053	Pull Disconnect (Opt) ①			X		X			X			X
NS	8615-051	Circuit Breaker 25A 3 Pole (Opt) ①								X			X
NS	4095-130	Wiring Diagram	X			X		X			X		
NS	4095-228	Wiring Diagram		X					X			X	
NS	4095-319	Wiring Diagram			X					X			
NS	4095-621	Wiring Diagram					X						X

① Circuit breakers listed are for units without electric heat, "0Z" models. Hot gas bypass models not available without electric heat. See Heater Replacement Parts Manual for units with electric heat.

# CONTROL PANEL

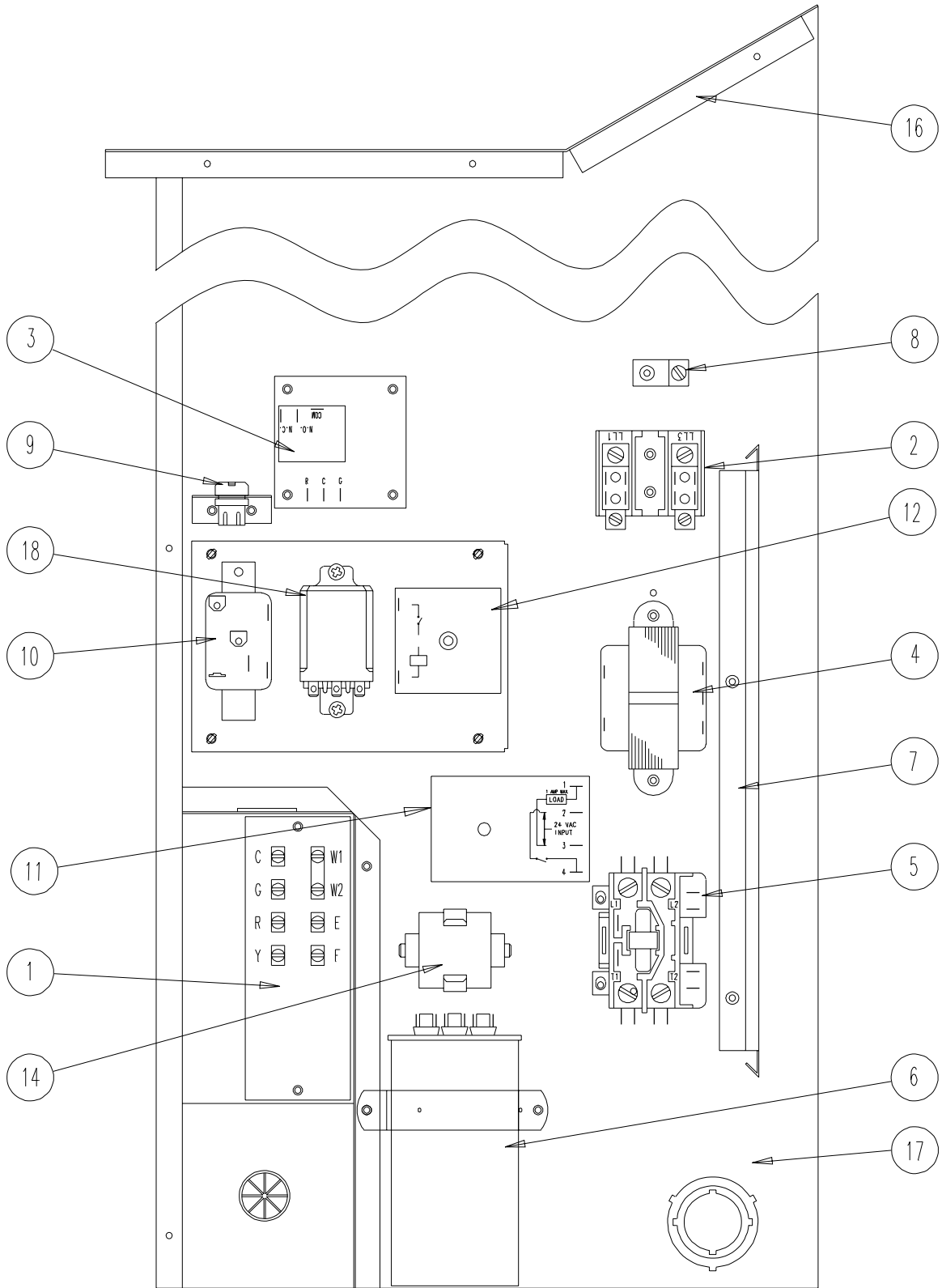

SEXP-332

# CONTROL PANEL

Drawing No.	Part No.	Description	WA301DA	WA361DA	WA301DB	WA361DB	WA301DC, WA361DC
1	8607-020	Low Voltage Terminal Strip	X	X	X	X	X
2	8607-013	Terminal Block 2 Pole	X	X			
2	8607-014	Terminal Block 3 Pole			X	X	X
2	8607-015	Phenolic Insulator					X
3	8201-056	Blower Control	X	X	X	X	
3	8201-032	Blower Relay					X
4	8407-035	Transformer	X	X	X	X	
4	8407-042	Transformer					X
5	8401-007	Compressor Contactor	X	X			
5	8401-002	Compressor Contactor			X	X	X
6	8552-050	Compressor Capacitor		X			
6	8552-002	Outdoor Motor Capacitor			X	X	X
6	8552-048	Compressor Capacitor	X				
7	135-122	Wire Shield	X	X	X	X	X
8	8611-006	Ground Terminal	X	X	X	X	X
9	3000-968	6 Pin Connector	X	X	X	X	X
10	8201-009	Relay SPDT	X	X	X	X	X
11	8201-089	Compressor TDR 10 sec. Off Delay	X	X	X	X	X
12	8201-050	Compressor TDR 5 min. Delay on Break	X	X	X	X	X
14	8551-005	Start Device (PTCR) (Optional)	X	X	X	X	X
16	117-137	Control Panel Top	X	X	X	X	X
17	117-123	Control Panel Top	X	X	X	X	X
18	8201-071	Relay 3PDT	X	X	X	X	X
NS	8615-038	Circuit Breaker 35 A 2 Pole (Optional) ①	X	X			
NS	8615-051	Circuit Breaker 25 A 3 Pole (Optional) ①				X	
NS	8615-054	Circuit Breaker 20 A 3 Pole (Optional) ①			X		
NS	8615-053	Pull Disconnect w/o Electric Heat (Optional) ①					X
NS	4095-118	Wiring Diagram	X	X			
NS	4095-221	Wiring Diagram			X	X	
NS	4095-315	Wiring Diagram					X

① Circuit breakers listed are for units without electric heat, "0Z" models. Hot gas bypass models not available without electric heat. See Heater Replacement Parts Manual for units with electric heat.

# BLOWER ASSEMBLY

Drawing No.	Part No.	Description	900-179	900-180
1	5152-051	Housing, Wheel and Cutoff (CW)	X	X
2	5152-052	Housing, Wheel and Cutoff	X	X
3	8105-029	Blower Motor (230/208)	X	
3	8105-033	Blower Motor (460)		X
4	8552-002	Capacitor	X	X
5	8200-031	Motor Mount	X	X
6	5451-011	Grommets	6	6
7	105-870	Back Brace	X	X
8	104-868	Side Angle	4	4
9	103-401	Front Brace	X	X

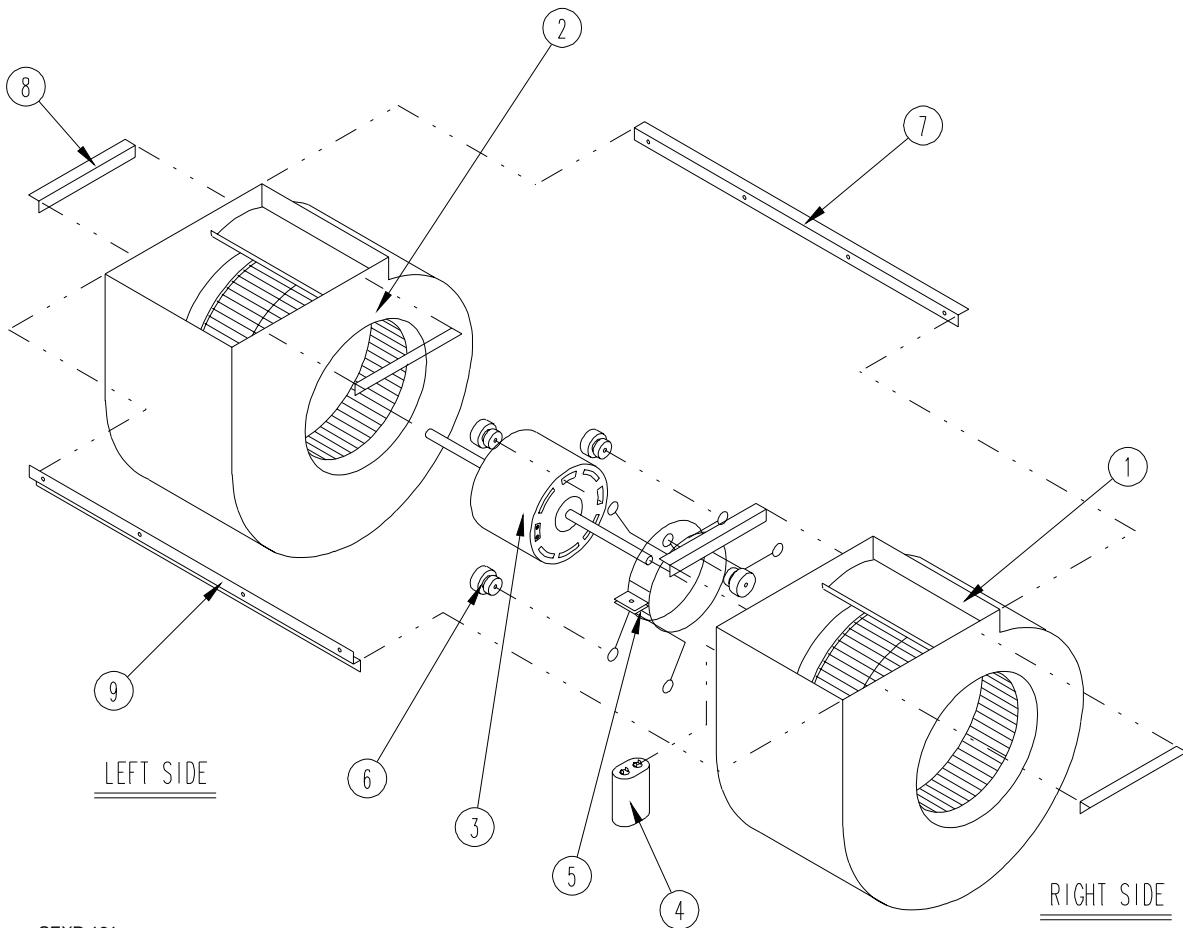

SEXP-161