Replacement Parts Manual

Wall Mounted Package Air Conditioner

Models: WA421 WA422D
 WA482 WA483D
 WA602 WA603D

General Notes

- Revised and/or additional pages may be issued from time to time.
- A complete and current manual consists of pages shown in the following contents section.

Important

- Contact the installing and/or local Bard distributor for all parts requirements. Make sure you have the complete model and serial number available from the unit rating plates.

Contents

Description	Page
Cabinet Components	
♦ Exploded View	1
♦ Usage List	2
Functional Components	
♦ Exploded View	3
♦ Usage List	4
♦ Usage List	5
Control Panel	
♦ Exploded View	6
♦ Usage List	7
♦ Usage List	8
Blower Assembly	
♦ Exploded View	9
♦ Usage List	9



BARD MANUFACTURING COMPANY
Bryan, Ohio 43506

Since 1914...Moving ahead, just as planned.

Manual: 2110-413I
Supersedes: 2110-413H
File: 2150-004, Tab 16
Date: 04-08-99

CABINET COMPONENTS

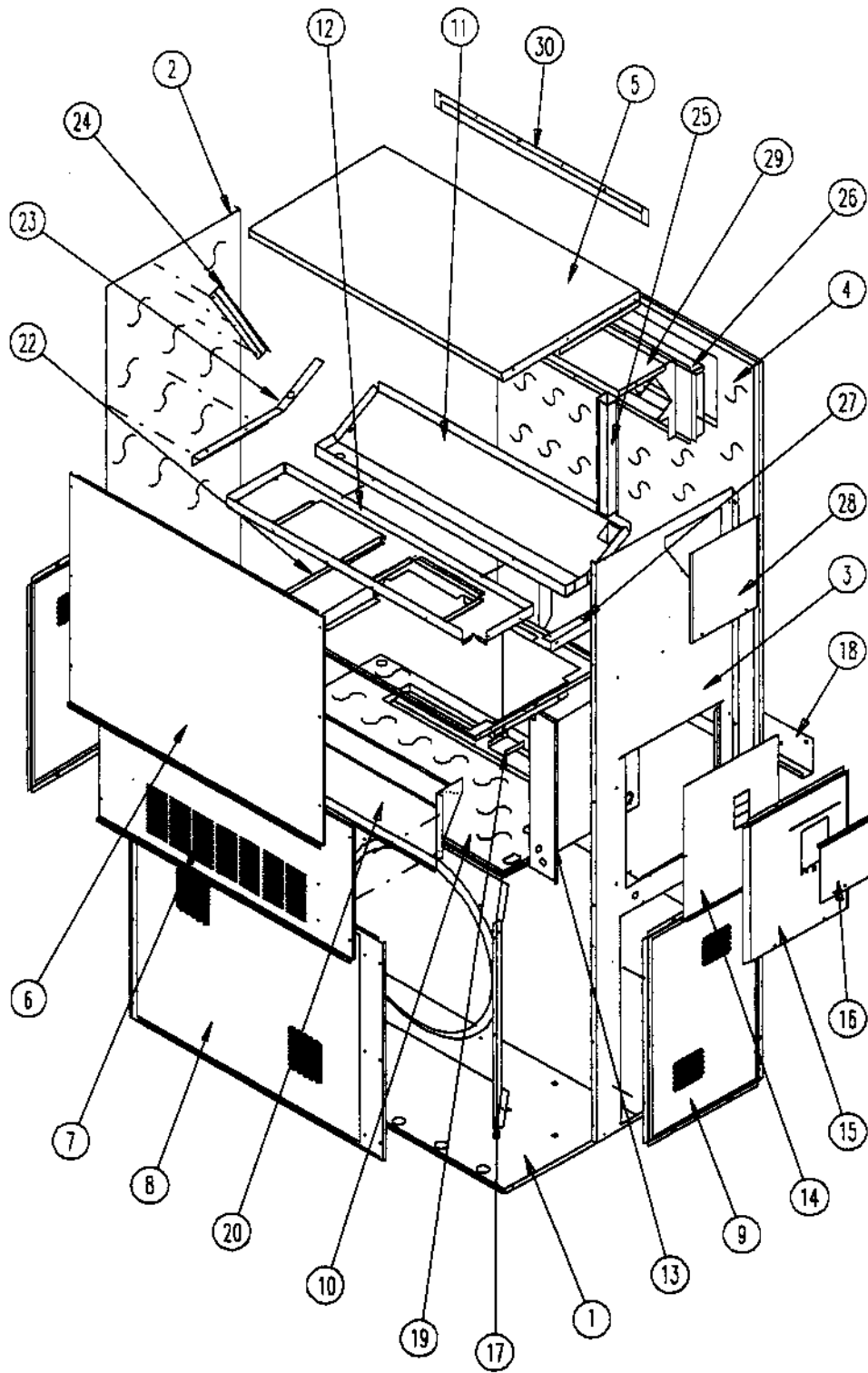

SEXP-175

CABINET COMPONENTS

Drawing No.	Part No.	Description	WA421-A,B,E	WA421-C,F	WA4222DA, B	WA422DC	WA482-A,B,E	WA482-C, F	WA483DA,B	WA483DC	WA602-A,B,E	WA602-C,F	WA603DA, B	WA603DC
1	S127Y214	Lower Base	X	X	X	X	X	X	X	X	X	X	X	X
2	S500-262-* ①	Left Side	X	X	X	X	X	X	X	X	X	X	X	X
3	S500-261-* ①	Right Side	X	X	X	X	X	X	X	X	X	X	X	X
4	S508-098	Back	X	X	X	X	X	X	X	X	X	X	X	X
5	S506-142-* ①	Top	X	X	X	X	X	X	X	X	X	X	X	X
6	S514-077-* ①	Upper Front	X	X	X	X	X	X	X	X	X	X	X	X
7	S552-224-* ①	Service Door	X	X	X	X	X	X	X	X	X	X	X	X
8	118-031-* ①	Condenser Grille	X	X	X	X	X	X	X	X	X	X	X	X
9	118-032-* ①	Side Grille	2	2	2	2	2	2	2	2	2	2	2	2
10	S521X258	Condenser Partition	X	X	X	X	X	X	X	X	X	X	X	X
11	123-083	Drain Pan	X	X	X	X	X	X	X	X	X	X	X	X
12	121X216	Blower Partition	X	X	X	X	X	X	X	X	X	X	X	X
13	Control Panel Assembly	See Control Panel Assembly Drawing & Parts List	X	X	X	X	X	X	X	X	X	X	X	X
14	S133-114	Control Panel Cover (Inner)	X		X		X		X		X		X	
14	S133-115	Control Panel Cover (Inner)		X		X		X		X		X		X
15	S533-113-* ①	Control Panel Cover (Outer)	X	X	X	X	X	X	X	X	X	X	X	X
16	S153-218-* ①	Disconnect Access Door	X	X	X	X	X	X	X	X	X	X	X	X
17	125-024	Fan Shroud	X	X	X	X	X	X	X	X	X	X	X	X
18	113-140	Bottom Mounting Bracket	X	X	X	X	X	X	X	X	X	X	X	X
19	137-209	Fill	X	X	X	X	X	X	X	X	X	X	X	X
20	962024	Fresh Air Damper Assembly	X	X	X	X	X	X	X	X	X	X	X	X
22	131X099	Filter Tray	X	X	X	X	X	X	X	X	X	X	X	X
23	105X877	Left Side Support	X	X	X	X	X	X	X	X	X	X	X	X
24	147-046-* ①	Left Evaporator Support	X	X	X	X	X	X	X	X	X	X	X	X
25	135-128	Raceway	2	2	2	2	2	2	2	2	2	2	2	2
26	111X034	Outlet Airframe Assembly	X	X	X	X	X	X	X	X	X	X	X	X
27	105X878	Right Side Support	X	X	X	X	X	X	X	X	X	X	X	X
28	S143-042-* ①	Right Side Cover Plate (Outer)	X	X	X	X	X	X	X	X	X	X	X	X
29	135-129	Heat Shield	X	X	X	X	X	X	X	X	X	X	X	X
30	113-150-* ①	Top Rain Flashing	X	X	X	X	X	X	X	X	X	X	X	X

① NOTE: Exterior cabinet parts are manufactured with various paint color options. To insure that you receive the proper paint color, you must include the complete model and serial number of the unit for which cabinet parts are being ordered.

FUNCTIONAL COMPONENTS

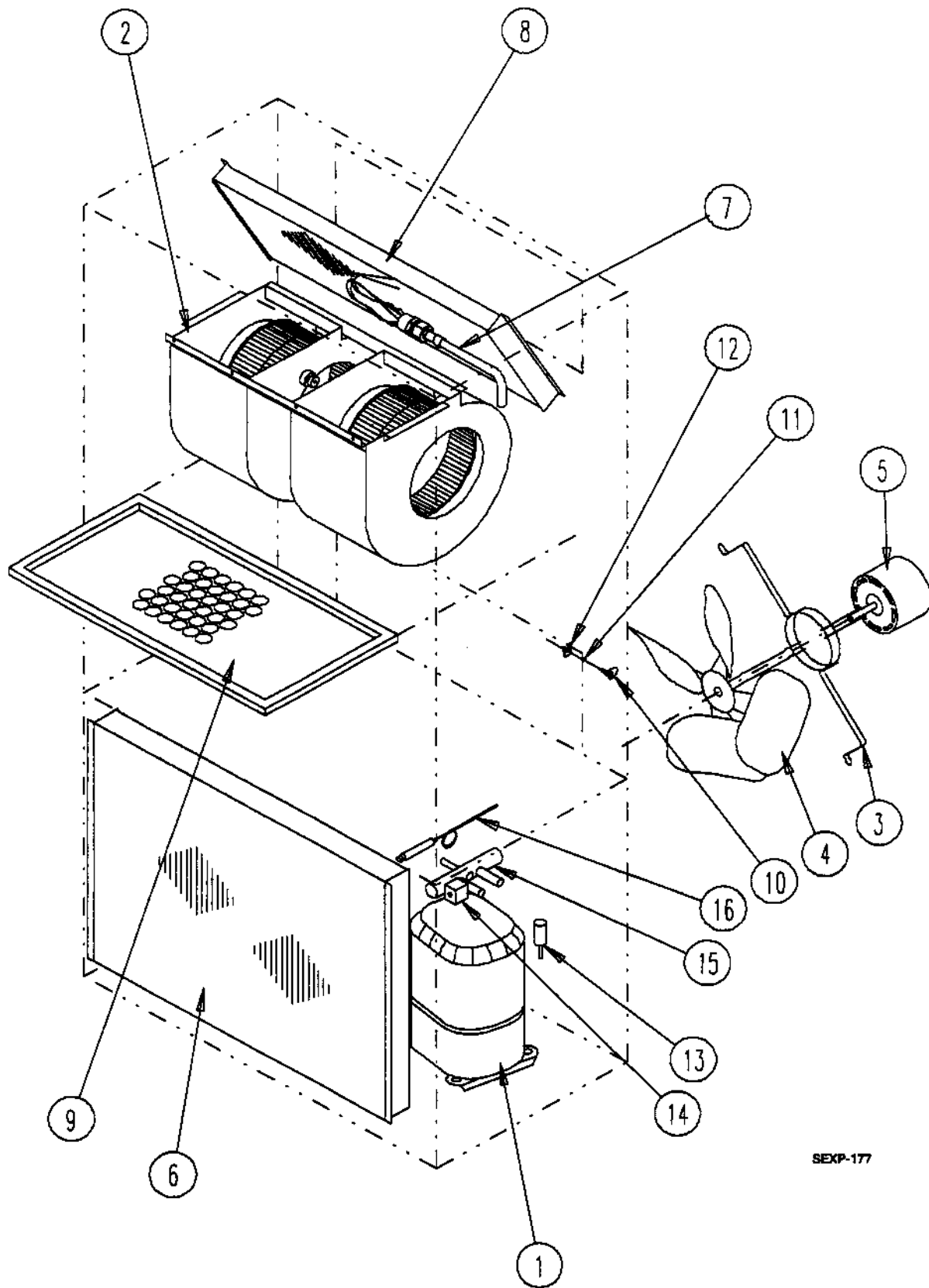

SEXP-177

This Exploded View references Tables on Page 4 and 5

FUNCTIONAL COMPONENTS

Drawing No.	Part No.	Description	WA421-A	WA421-B, E	WA421-C	WA421-F	WA422DA	WA422DB	WA422DC
1	8000-126	Compressor	X						
1	8000-127	Compressor		X				X	
1	8000-128	Compressor				X	X		X
2	S900-183	Blower Assembly	X	X		X	X	X	
2	S900-184	Blower Assembly			X				X
3	8200-004	Fan Motor Mount	X	X	X	X	X	X	X
4	5151-027	Fan Blade	X	X	X	X	X	X	X
5	8105-030	Condenser Motor			X				X
5	8105-039	Condenser Motor	X	X		X	X	X	
6	5051-078	Condenser Coil	X	X	X	X	X	X	X
7	5651-078	Expansion Valve					X	X	X
7	800-0203	Cooling Capillary Assembly	X	X	X	X			
8	5060-070	Evaporator Coil	X	X	X	X			
8	917-0042	Evaporator Coil					X	X	X
9	7004-016	Air Filter 1" Throw-Away	X	X	X	X	X	X	X
9	7003-030	Air Filter 1" Washable	X	X	X	X	X	X	X
9	7004-027	Air Filter 2" Pleated	X	X	X	X	X	X	X
10	1171-022	1/4" Turn Fastener	X	X	X	X	X	X	X
11	1171-024	1/4" Turn Retainer	X	X	X	X	X	X	X
12	1171-023	1/4" Receptacle	X	X	X	X	X	X	X
13	1804-0106	High Pressure Switch (Solder)	⊕	⊕	⊕	⊕			
14	5650-027	Solenoid Coil					X	X	X
15	5650-026	Three-Way Valve					X	X	X
16	800-0271	Drain Back Capillary					X	X	X
NS	1804-0107	Low Pressure Switch (Flare)	⊕	X	X	X			
NS	CMA-6	Low Ambient Control (Flare)	⊕	X	X	X			

NS - Not Shown

⊕ - Optional on these models

This Table references Exploded View on Page 3

FUNCTIONAL COMPONENTS

Dwg. No.	Part No.	Description	WA482-A	WA482-B,E	WA482-C	WA482-F	WA483DA	WA483DB	WA483DC	WA602-A	WA602-B,E	WA602-C	WA602-F	WA603DA	WA603DB	WA603DC
1	8000-153	Compressor								X				X		
1	8000-154	Compressor									X				X	
1	8000-155	Compressor										X	X			X
1	8000-149	Compressor	X				X									
1	8000-156	Compressor		X				X								
1	8000-157	Compressor			X	X			X							
2	S900-183	Blower Assembly	X	X		X	X	X								
2	S900-184	Blower Assembly			X				X							
2	S900-185	Blower Assembly								X	X					
2	S900-186	Blower Assembly										X	X	X	X	X
3	8200-004	Fan Motor Mount	X	X	X	X	X	X	X	X	X	X	X	X	X	X
4	5151-027	Fan Blade	X	X	X	X	X	X	X	X	X	X	X	X	X	X
5	8105-030	Condenser Motor			X				X			X				X
5	8105-039	Condenser Motor	X	X		X	X	X		X	X		X	X	X	
6	5051-074	Condenser Coil	X	X	X	X	X	X	X	X	X	X	X	X	X	X
7	5651-078	Expansion Valve					X	X	X							
7	5651-079	Expansion Valve												X	X	X
7	800-0204	Cooling Capillary Assembly	X	X	X	X										
7	800-209	Cool. Cap. Assy.(S/N before M95)								X	X	X	X			
7	800-23	Cool. Cap. Assy.(S/N starting M95)								X	X	X	X			
8	5060-0	Evaporator Coil	X	X	X	X										
8	5060-071	Evap. Coil (S/N before M95)								X	X	X	X			
8	5060-082	Evap. Coil (S/N starting M95)								X	X	X	X			
8	917-0042	Evaporator Coil					X	X	X							
8	917-0044	Evaporator Coil												X	X	X
9	7004-016	Air Filter 1" Throw-Away	X	X	X	X	X	X	X	X	X	X	X	X	X	X
9	7003-030	Air Filter 1" Washable	X	X	X	X	X	X	X	X	X	X	X	X	X	X
9	7004-027	Air Filter 2" Pleated	X	X	X	X	X	X	X	X	X	X	X	X	X	X
10	1171-022	1/4" Turn Fastener	X	X	X	X	X	X	X	X	X	X	X	X	X	X
11	1171-024	1/4" Turn Retainer	X	X	X	X	X	X	X	X	X	X	X	X	X	X
13	1804-0106	High Pressure Switch (Flare) ①	X	X	X	X	X	X	X	X	X	X	X	X	X	X
14	5650-027	Solenoid Coil					X	X	X					X	X	X
15	5650-026	Three-Way Valve					X	X	X					X	X	X
16	800-0272	Drain Back Capillary					X	X	X					X	X	X
NS	CMA-6	Low Ambient Control (Flare)	①	X	X	X	X				X	X	X	X		
NS	1804-0107	Low Pressure Switch (Flare) ①	X	X	X	X				X	X	X	X			

NS - Not Shown

① - Optional on these models

This Table references Exploded View on Page 3

This page left blank intentionally.

Control Panel

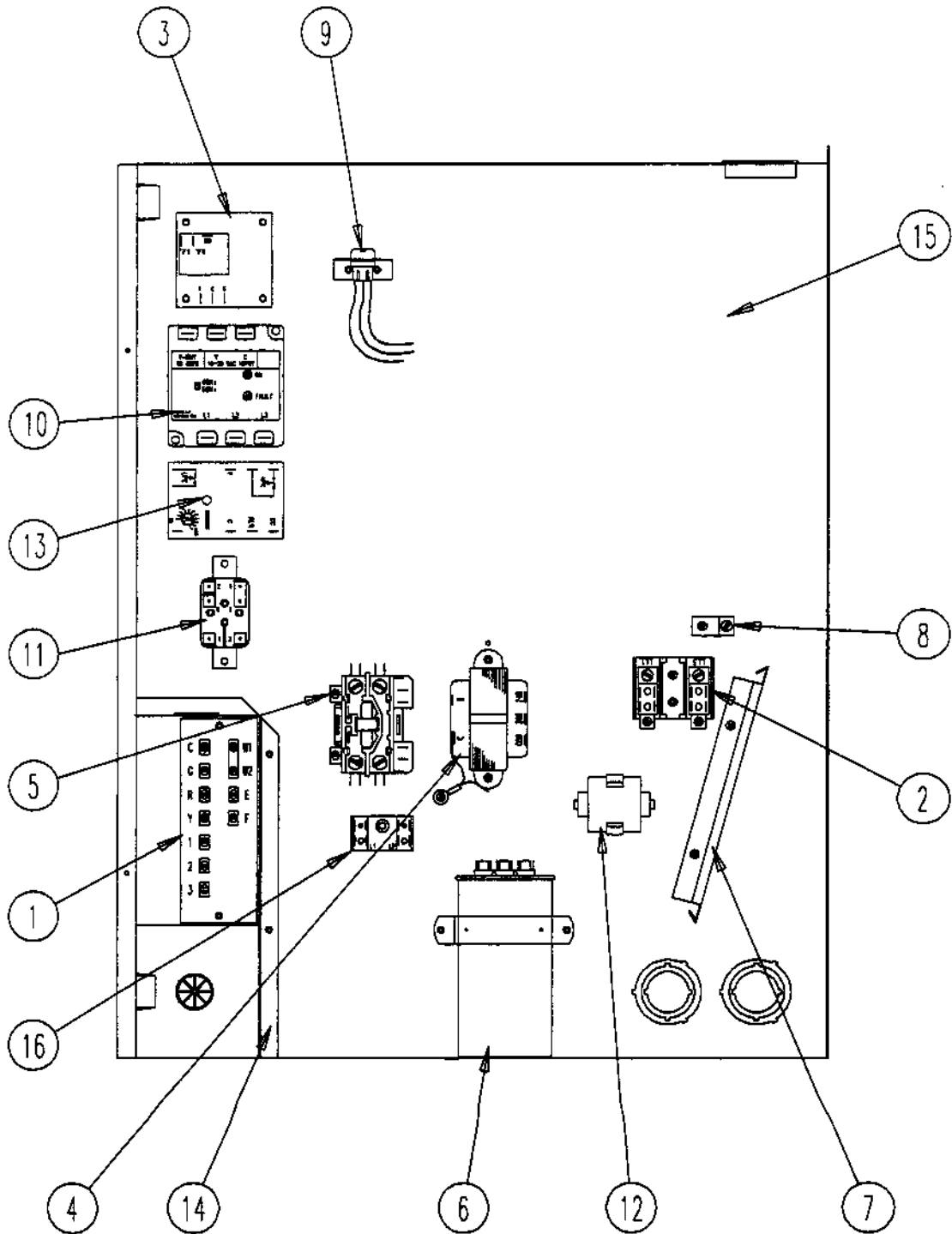

SEXP-325

CONTROL PANEL

Drawing No.	Part No.	Description	WA421-A	WA421-B	WA421-C	WA421-E	WA421-F	WA482-A	WA482-B	WA482-C	WA482-E	WA482-F	WA602-A	WA602-B	WA602-C	WA602-E	WA602-F	
1	8607-020	Low Voltage Terminal Strip	X	X	X	X	X	X	X	X	X							
2	8607-013	Terminal Block 2 Pole	X				2	X				2	X					2
2	8607-014	Terminal Block 3 Pole		X	X	X			X	X	X			X	X	X		
2	8607-015	Phenolic Insulator			X					X					X			
3	8201-056	Blower Control	X	X		X	X	X	X	X	X	X	X	X	X	X	X	X
3	8201-032	Blower Relay			X					X					X			
4	8407-034	Transformer	X	X		X	X	X	X		X	X	X	X		X	X	
4	8407-042	Transformer			X					X					X			
5	8401-002	Compressor Contactor		X	X	X	X		X	X	X	X		X	X	X	X	
5	8401-007	Compressor Contactor	X															
5	8401-016	Compressor Contactor						X					X					
6	8552-005	Outdoor Motor Capacitor		X		X	X		X		X	X		X		X	X	
6	8552-026	Outdoor Motor Capacitor			X					X					X			
6	8552-055	Compressor Capacitor	X															
6	8552-059	Compressor Capacitor						X										
6	8552-058	Caompressor Capacitor											X					
7	135-130	Wire Shield	X	X	X	X	X	X	X	X	X	X	X	X	X	X	X	X
8	8611-006	Ground Terminal	X	X	X	X	X	X	X	X	X	X	X	X	X	X	X	X
9	3000-978	6 Pin Connector	X	X	X	X	X	X	X	X	X	X	X	X	X	X	X	X
10	8201-085	Phase Monitor		X	X	X	X		X	X	X	X		X	X	X	X	
11	8201-062	Alarm Relay (Optional)	X	X	X	X	X	X	X	X	X	X	X	X	X	X	X	X
12	8551-005	Start Device (PTCR) (Optional)	X					X					X					
13	8201-087	Compressor Control Module	⓪	⓪	⓪	⓪	⓪	X	X	X	X	X	X	X	X	X	X	X
14	117X139	Low Voltage Box	X	X	X	X	X	X	X	X	X	X	X	X	X	X	X	X
15	117X143	Control Panel	X	X	X	X	X	X	X	X	X	X	X	X	X	X	X	X
16	8607-017	Terminal Block (Optional)	X	X	X	X	X	X	X	X	X	X	X	X	X	X	X	X
NS	4095-130	Wiring Diagram	X															
NS	4095-128	Wiring Diagram						X					X					
NS	4095-228	Wiring Diagram		X														
NS	4095-227	Wiring Diagram							X					X				
NS	4095-229	Wiring Diagram									X					X		
NS	4095-230	Wiring Diagram				X												
NS	4095-319	Wiring Diagram			X													
NS	4095-318	Wiring Diagram							X						X			
NS	4095-623	Wiring Diagram									X							X
NS	4095-622	Wiring Diagram					X											

⓪ Optional on these models.
 NS Not shown

CONTROL PANEL

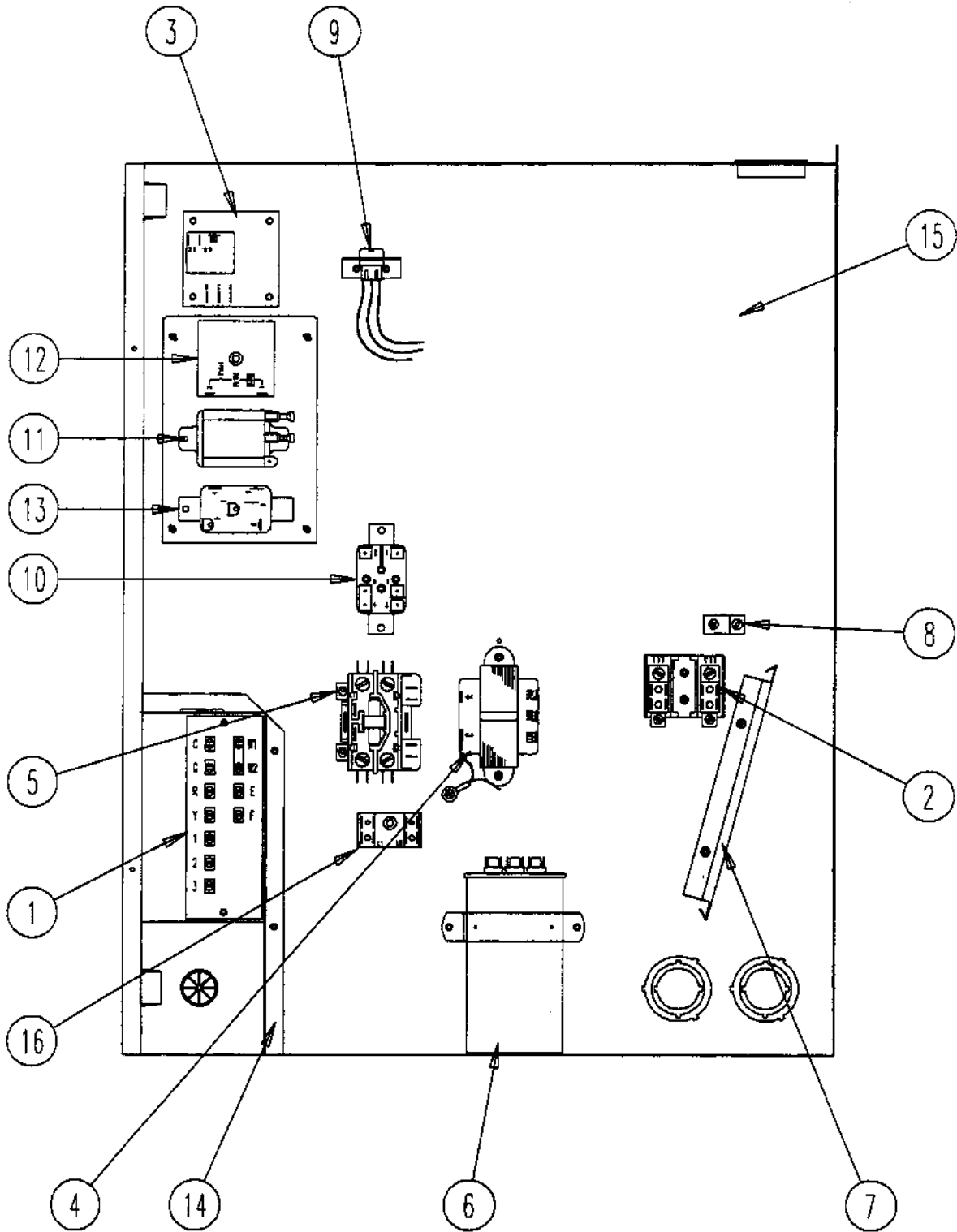

SEXP-326

CONTROL PANEL

Drawing			WA422DA	WA422DB	WA422DC	WA483DA	WA483DB	WA483DC	WA603DA	WA603DB	WA603DC
No.	Part No.	Description									
1	8607-020	Low Voltage Terminal Strip	X	X	X	X	X	X	X	X	X
2	8607-013	Terminal Block 2 Pole	X			X			X		
2	8607-014	Terminal Block 3 Pole		X	X		X	X		X	X
2	8607-015	Phenolic Insulator			X			X			X
3	8201-056	Blower Control	X	X		X	X		X	X	
3	8201-032	Blower Relay			X			X			X
4	8407-035	Transformer	X	X		X	X		X	X	
4	8407-042	Transformer			X			X			X
5	8401-002	Compressor Contactor		X	X		X	X		X	X
5	8401-016	Compressor Contactor				X			X		
5	5401-007	Compressor Contactor	X								
6	8552-005	Outdoor Motor Capacitor 10 MFD-370V		X			X			X	
6	8552-026	Outdoor Motor Capacitor 15 MFD-370V			X			X			X
6	8552-058	Compressor Capacitor 80/10 MFD-370V							X		
6	8552-059	Compressor Capacitor 60/10 MFD-370V				X					
6	8552-055	Compressor Capacitor 40/10 MFD-370V	X								
7	135-130	Wire Shield	X	X	X	X	X	X	X	X	X
8	8611-006	Ground Terminal	X	X	X	X	X	X	X	X	X
9	3000-978	6 Pin Connector	X	X	X	X	X	X	X	X	X
10	8201-034	Lockout Relay	X	X	X	X	X	X			
11	8201-071	Control Relay #1	X	X	X	X	X	X	X	X	X
12	8201-050	Compressor TDR	X	X	X	X	X	X	X	X	X
13	8201-062	Control Relay #2	X	X	X	X	X	X	X	X	X
14	117X139	Low Voltage Box	X	X	X	X	X	X	X	X	X
15	117X143	Control Panel	X	X	X	X	X	X	X	X	X
16	8607-017	Terminal Block (Optional)	X	X	X	X	X	X	X	X	X
NS	4095-118	Wiring Diagram	X								
NS	4095-121	Wiring Diagram				X			X		
NS	4095-220	Wiring Diagram					X			X	
NS	4095-221	Wiring Diagram		X							
NS	4095-315	Wiring Diagram			X						
NS	4095-316	Wiring Diagram						X			X

Ⓞ Optional on these models.
 NS Not shown

BLOWER ASSEMBLY

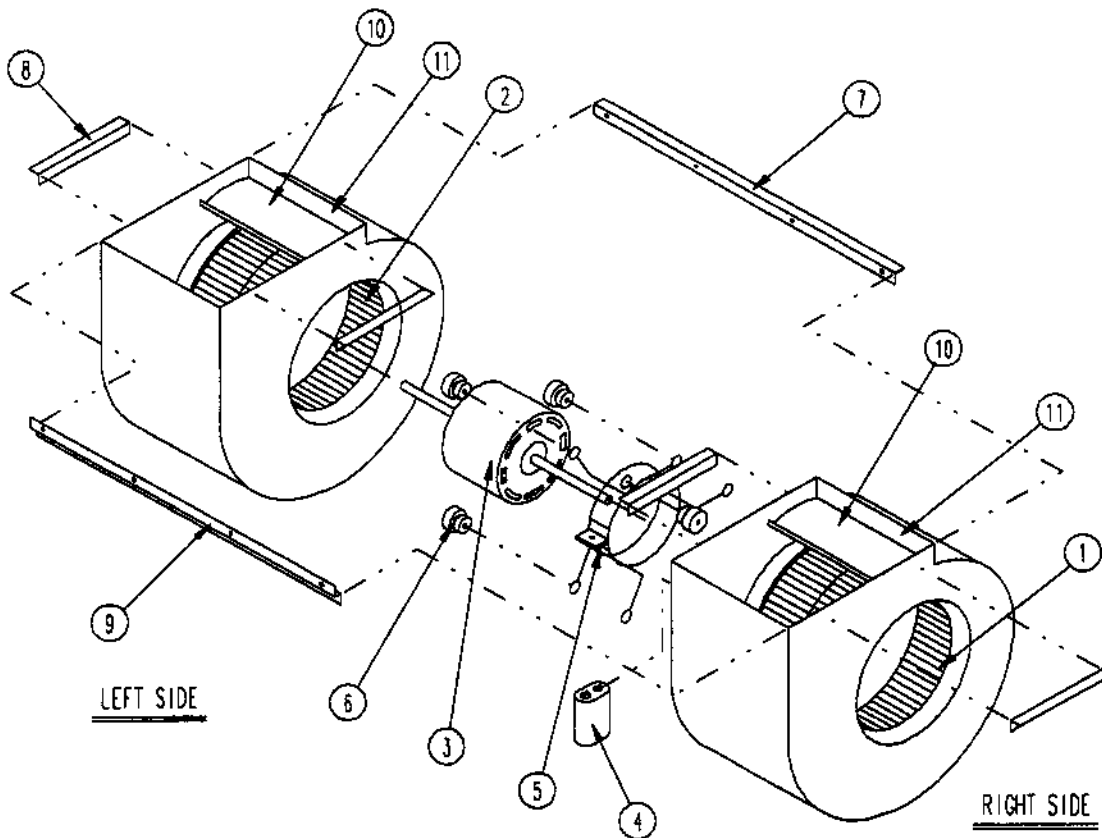

SEXP-17B

Drawing No.	Part No.	Description	900-183	900-184	900-185	900-186
1	5152-011	10 Inch Wheel (CW)			X	X
1	5152-057	9 Inch Wheel (CW)	X	X		
2	5152-012	10 Inch Wheel (CCW)			X	X
2	5152-058	9 Inch Wheel (CCW)	X	X		
3	8106-030	Blower Motor (230/208)	X		X	
3	8106-025	Blower Motor (460)		X		X
4	8552-005	Capacitor	X	X	X	X
5	8200-040	Motor Mount	X	X	X	X
6	5451-011	Grommets	6	6	6	6
7	105-880	Back Brace	X	X	X	X
8	105-881	Side Angle	4	4	4	4
9	103-389	Front Brace	X	X	X	X
10	151-101	Housing	2	2	2	2
11	144-166	Diffuser	2	2	2	2