REPLACEMENT PARTS MANUAL

WALL MOUNTED PACKAGE AIR CONDITIONER

Models: **WL421T WL482T
WL602T**

General Notes

- Revised and/or additional pages may be issued from time to time.
- A complete and current manual consists of pages shown in the following contents section.

Contents

<u>Description</u>	<u>Page</u>
Cabinet Components	
♦ Exploded View	1
♦ Usage List	2
Functional Components	
♦ Exploded View	3
♦ Usage List	4
Control Panel	
♦ Exploded View	5
♦ Usage List	6
Blower Assembly	
♦ Exploded View	7
♦ Usage List	7



BARD MANUFACTURING COMPANY
Bryan, Ohio 43506
Since 1914...Moving ahead, just as planned.

Manual: 2110-421B
Supersedes: 2110-421A
File: 2150-004 Tab 16
Date: 09-20-01

CABINET COMPONENTS

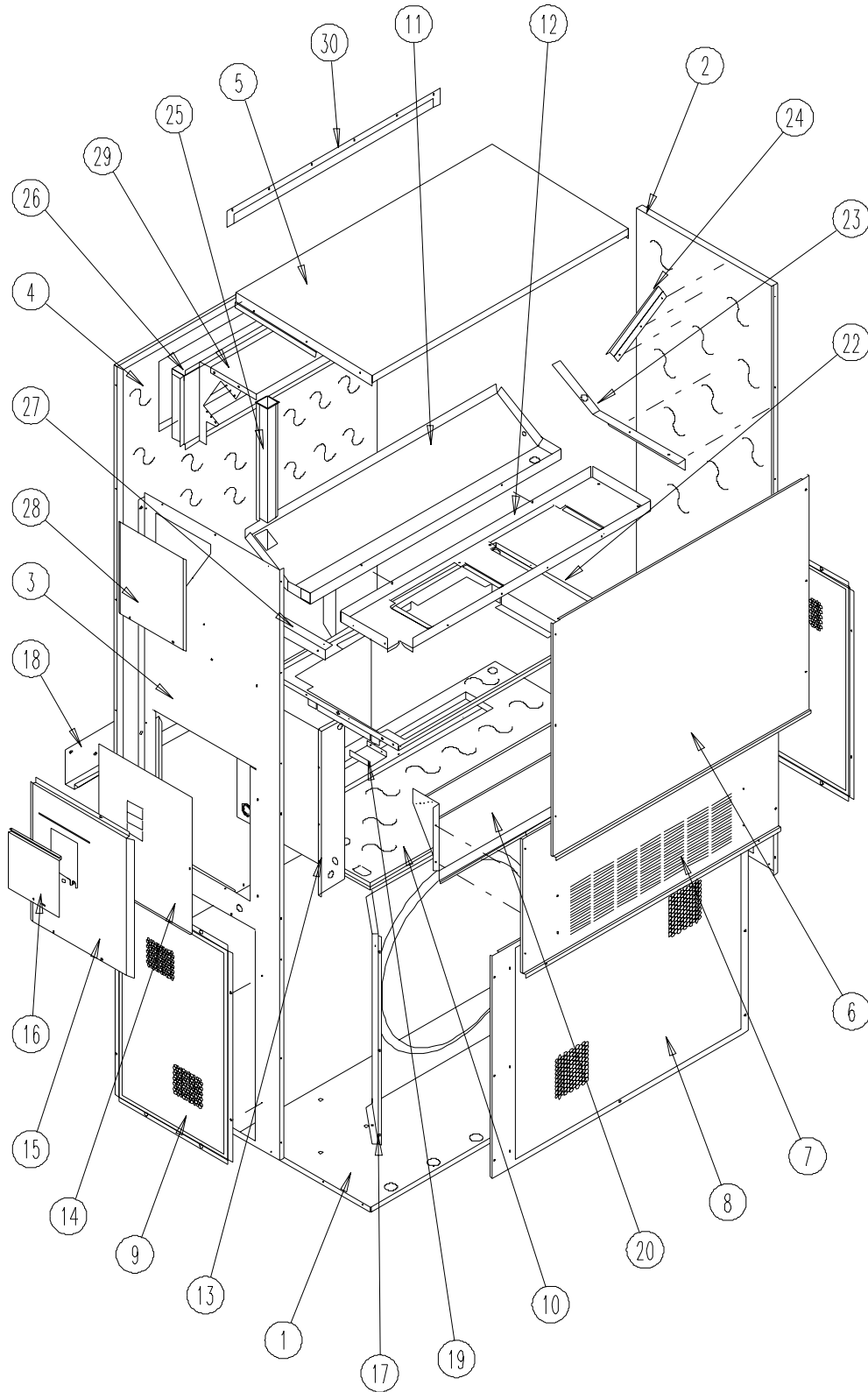

SEXP-236

CABINET COMPONENTS

Drawing No.	Part No.	Description	WL421TA	WL482TB	WL602TB	WL602TN
1	S127Y214	Lower Base	X	X	X	X
2	S500-320-* ①	Left Side	X	X	X	X
3	S500-319-* ①	Right Side	X	X	X	X
4	S508-098	Back	X	X	X	X
5	S506-142-* ①	Top	X	X	X	X
6	S514-077-* ①	Upper Front	X	X	X	X
7	S552-224	Service Door	X	X	X	X
8	118-031-* ①	Condenser Grille	X	X	X	X
9	118-032-* ①	Side Grille	2	2	2	2
10	S520Y258	Condenser Partition	X	X	X	X
11	123-091	Drain Pan	X	X	X	X
12	121Y216	Blower Partition	X	X	X	X
13	Control Panel Assy.	See Control Panel Assembly Drawing & Parts List	X	X	X	X
14	S133-114	Control Panel Cover (Inner)	X	X	X	
14	S133-115	Control Panel Cover (Inner)				X
15	S533-140-* ①	Control Panel Cover (Outer)	X	X	X	X
16	S153-218-* ①	Disconnect Access Door	X	X	X	X
17	125-024	Fan Shroud	X	X	X	X
18	113-140	Bottom Mounting Bracket	X	X	X	X
19	137-209	Fill	X	X	X	X
20	BFAD-5	Fresh Air Damper Assembly	X	X	X	X
22	131Y099	Filter Tray	X	X	X	X
23	105Y878	Left Side Support	X	X	X	X
24	147-046-* ①	Left Evaporator Support	X	X	X	X
25	135-128	Raceway	2	2	2	2
26	111Y034	Outlet Airframe Assembly	X	X	X	X
27	105Y877	Right Side Support	X	X	X	X
28	S143-042-* ①	Right Side Cover Plate (Outer)	X	X	X	X
29	135-129	Heat Shield	X	X	X	X
30	113-150-* ①	Top Rain Flashing	X	X	X	X

① Exterior cabinet parts are manufactured with various color options. To insure that you receive the proper color, you must include the complete models and serial number of the unit for which parts are being ordered.

FUNCTIONAL COMPONENTS

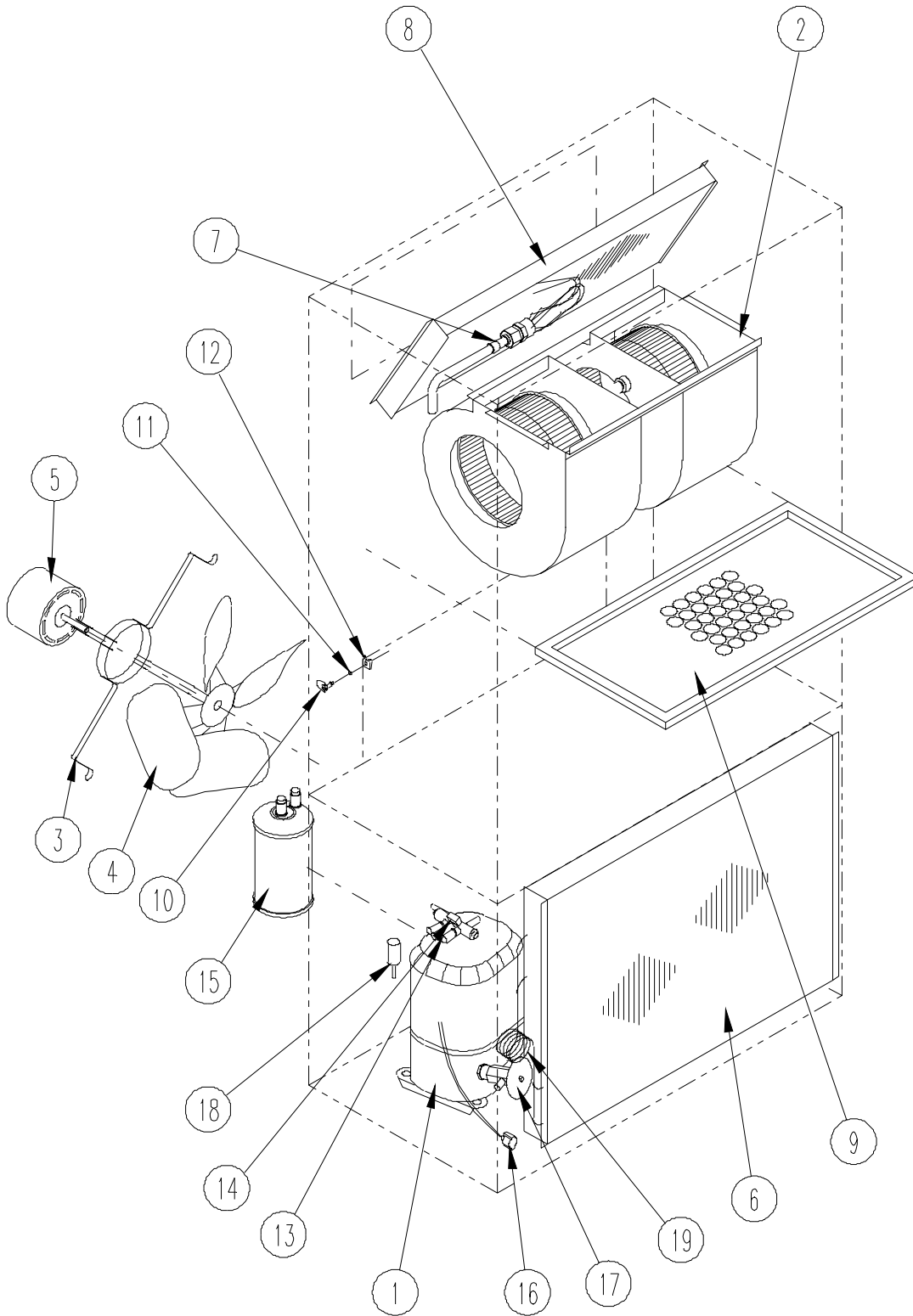

SEXP-237

FUNCTIONAL COMPONENTS

Drawing			WL421TA	WL482TB	WL602TB	WL602TN
No.	Part No.	Description				
1	8000-154	Compressor			X	
1	8000-209	Compressor				X
1	8000-126	Compressor	X			
1	8000-156	Compressor		X		
2	S900-183	Blower Assembly	X	X		
2	S900-185	Blower Assembly			X	X
3	8200-004	Fan Motor Mount	X	X	X	X
4	5151-027	Fan Blade	X	X	X	X
5	8105-042	Condenser Motor	X	X	X	X
6	5051-094	Condenser Coil		X	X	X
6	8051-093	Condenser Coil	X			
7	800-0204	Cooling Capillary Assembly		X		
7	800-0203	Cooling Capillary Assembly	X			
7	800-0234	Distributor Assembly			X	X
8	5060-070	Evaporator Coil	X	X		
8	5060-082	Evaporator Coil			X	X
9	7004-016	Air Filter 1" Throw Away	X	X	X	X
9	7003-030	Air Filter 1" Washable	X	X	X	X
9	7004-027	Air Filter 2" Pleated	X	X	X	X
10	1171-022	1/4 Turn Fastener	X	X	X	X
11	1171-024	1/4 Turn Retainer	X	X	X	X
12	1171-023	1/4 Receptacle	X	X	X	X
NS	1804-0106	High Pressure Switch (Flare)	①	X	X	X
NS	1804-0107	Low Pressure Switch (Flare)	X	X	X	X
NS	8406-087	Modulating Low Ambient Control	X	X	X	X

NS – Not Shown

① – Optional

CONTROL PANEL

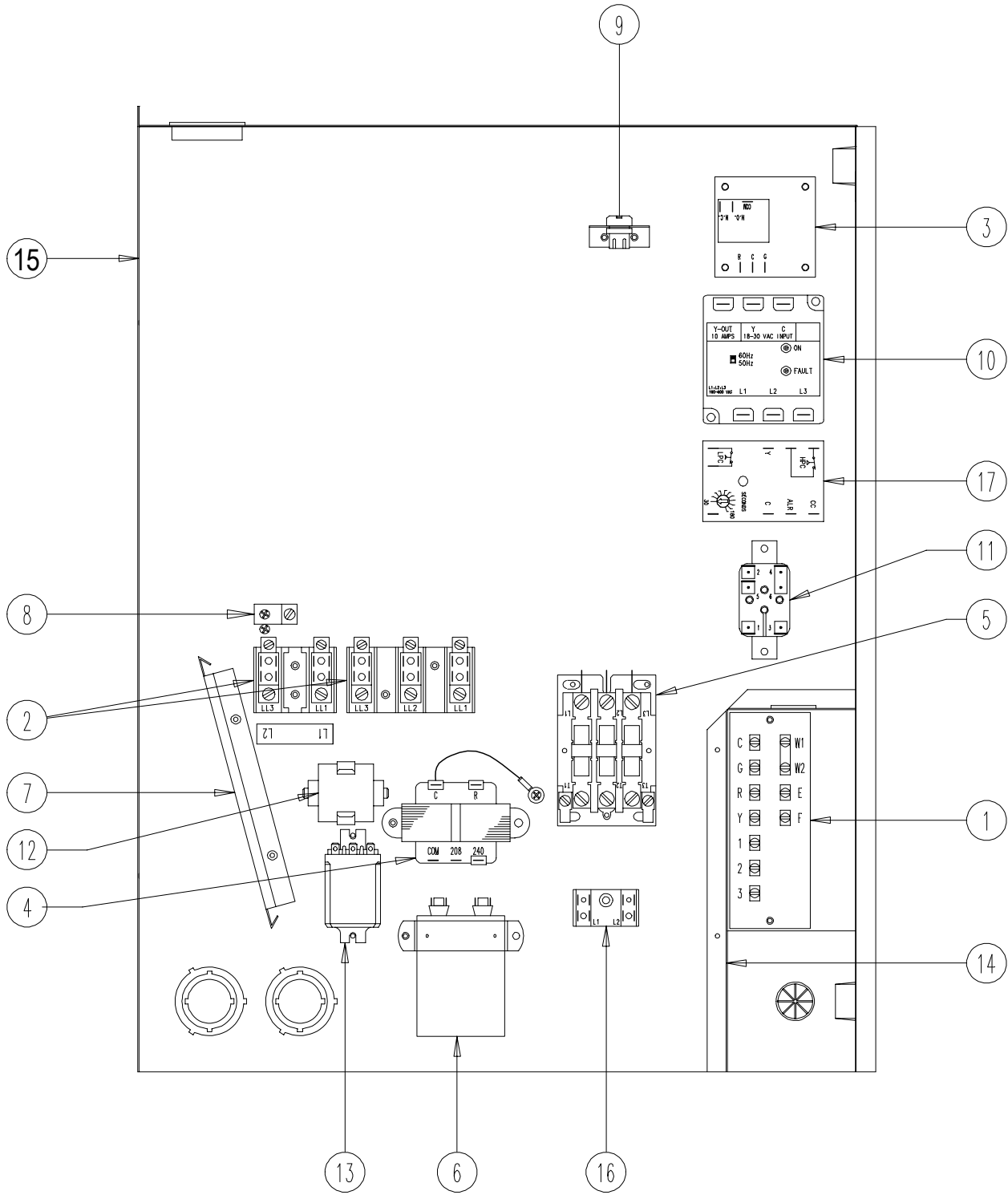

SEXP-251

CONTROL PANEL

Drawing No.	Part No.	Description	WL421TA	WL482TB	WL602TB	WL602TN
1	8607-020	Low Voltage Terminal Strip	X	X	X	X
2	8607-013	Terminal Block 2 Pole	2	X	X	3
2	8607-014	Terminal Block 3 Pole		X	X	
2	134-051	Phenolic Insulator				2
3	8201-056	Blower Control	X	X	X	X
4	8407-034	Transformer	X	X	X	X
5	8401-002	Compressor Contact		X	X	X
5	8401-007	Compressor Contact	X			
6	8552-005	Outdoor Motor Capacitor		X	X	X
6	8552-055	Compressor Capacitor	X			
7	135-130	Wire Shield	X	X	X	X
8	8611-006	Ground Terminal	X	X	X	X
9	3000-1066	6 Pin Connector	X	X	X	X
10	8301-085	Phase Monitor		X	X	X
11	8201-062	Alarm Relay	X	X	X	X
12	8552-003	Start Kit	X			
13	8201-074	Inverter Relay	X	X	X	X
14	117-139	Low Voltage Box	X	X	X	X
15	117-143	Control Panel	X	X	X	X
16	8607-017	Terminal Block	X	X	X	X
17	8201-087	Compressor Control Module	X	X	X	X
NS	4095-131	Wiring Diagram	X			
NS	4095-232	Wiring Diagram		X	X	
NS	4095-704	Wiring Diagram				X

NS – Not Shown

BLOWER ASSEMBLY

Drawing No.	Part No.	Description	900-183	900-185
1	5152-011	10 Inch Wheel (CW)		X
1	5152-057	9 Inch Wheel (CW)	X	
2	5152-012	10 Inch Wheel (CCW)		X
2	5152-058	9 Inch Wheel (CCW)	X	
3	8106-030	Blower Motor (230/208)	X	X
4	8552-005	Capacitor	X	X
5	8200-040	Motor Mount	X	X
6	5451-011	Grommets	6	6
7	105-880	Back Brace	X	X
8	105-881	Side Angle	4	4
9	103-389	Front Brace	X	X
10	151-101	Housing	2	2
11	144-166	Diffuser	2	2

