

---

# REPLACEMENT PARTS MANUAL

# WALL MOUNTED PACKAGE AIR CONDITIONER

Models: **WL301T, WL361T**

---

## General Notes

- Revised and/or additional pages may be issued from time to time.
- A complete and current manual consists of pages shown in the following contents section.

## Important

- Contact the installing and/or local Bard distributor for all parts requirements. Make sure you have the complete model and serial number available from the unit rating plate.

## Contents

Description	Page
Cabinet Components	
♦ Exploded View .....	1
♦ Usage List .....	2
Functional Components	
♦ Exploded View .....	3
♦ Usage List .....	4
Control Panel	
♦ Layout View .....	5
♦ Usage List .....	6
Blower Housing	
♦ Exploded View .....	7
♦ Usage List .....	7



BARD MANUFACTURING COMPANY  
Bryan, Ohio 43506  
*Since 1914...Moving ahead, just as planned.*

Manual: 2110-423B  
Supersedes: 2110-423A  
File: 2150-004, Tab 16  
Date: 09-03-02

# CABINET COMPONENTS

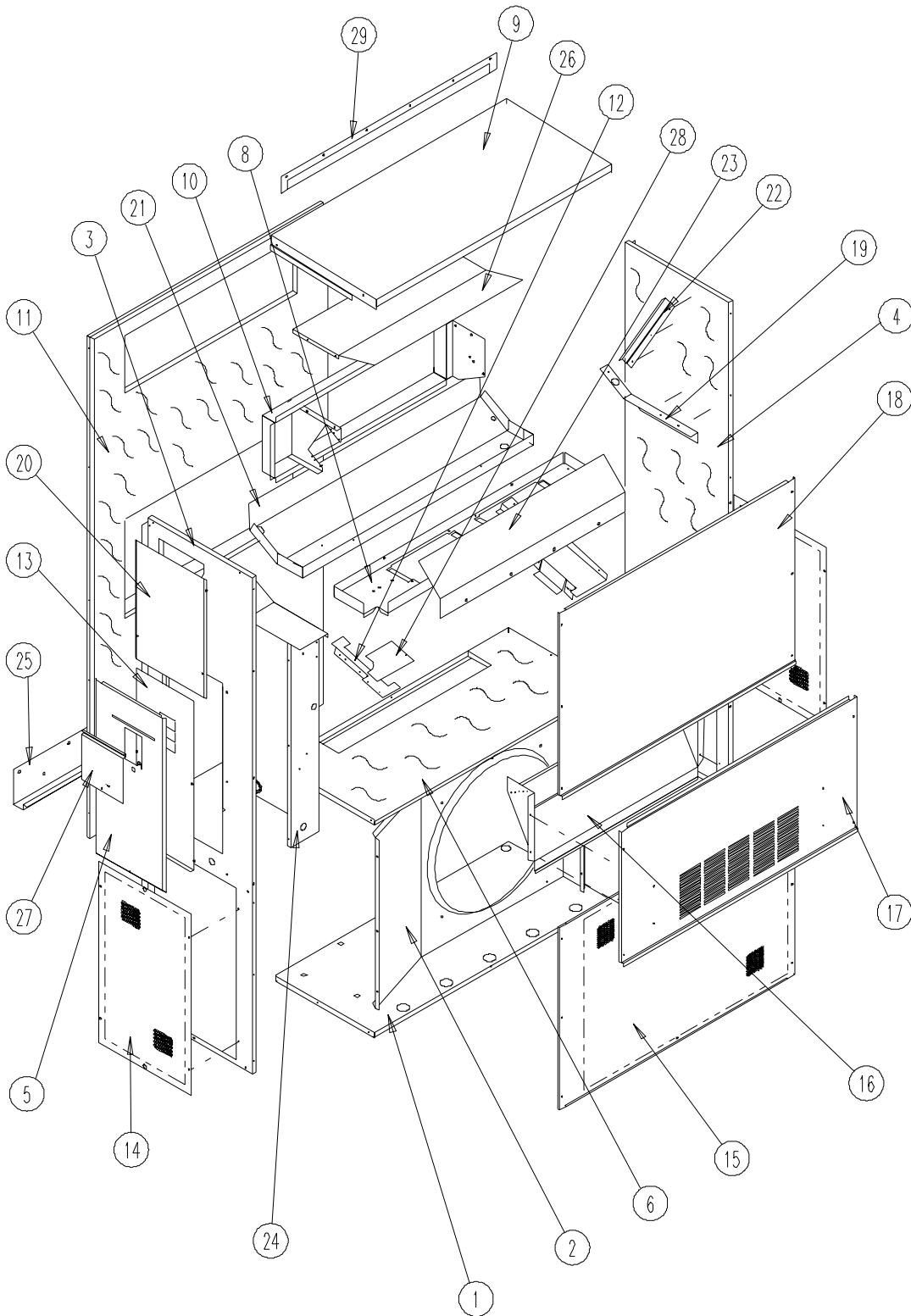

# CABINET COMPONENTS

Drawing No.	Part No.	Description	WL301TA, TB	WL301TN	WL361TA, TB	WL361TN
1	S127-199	Lower Base	X	X	X	X
2	125-022	Fan Shroud	X	X	X	X
3	S500-318-* (1)	Left Side	X	X	X	X
4	S500-317-* (1)	Right Side	X	X	X	X
5	S533-136-* (1)	Control Panel Cover (outer)	X	X	X	X
6	S521Y181	Condenser Partition	X	X	X	X
8	121Y182	Blower Partition	X	X	X	X
9	S506-130-* (1)	Top	X	X	X	X
10	S111Y030	Outlet Airframe Assembly	X	X	X	X
11	S508-088	Back	X	X	X	X
12	113Y195	Filter Bracket	2	2	2	2
13	S132-104	Control Panel Cover (inner)	X		X	
13	S132-110	Control Panel Cover (inner)		X		X
14	118-056-* (1)	Side Grille	2	2	2	2
15	118-047-* (1)	Condenser Grille	X	X	X	X
16	962014	Fresh Air Damper Assembly	X	X	X	X
17	S552-206-* (1)	Service Door	X	X	X	X
18	S514-072-* (1)	Upper Front	X	X	X	X
19	105Y850	Left Side Support	X	X	X	X
20	S143-034-* (1)	Side Cover Plate (outer)	X	X	X	X
21	S123-090	Drain Pan	X	X	X	X
22	147-044-* (1)	Right Evaporator Support	X	X	X	X
23	135-124	Air Baffle	X	X	X	X
24	Control Panel Assembly	(See Control Panel Assembly Drawing and Parts List)	X	X	X	X
25	113-140	Bottom Mounting Bracket	1	1	1	1
26	135Y123	Heat Shield	X	X	X	X
27	S153-218-* (1)	Disconnect Access Door	X	X	X	X
28	137-259	Fill Plate	X	X	X	X
29	113-149-* (1)	Top Rain Flashing	X	X	X	X

(1) Exterior cabinet parts are manufactured with various color options. To insure that you receive the proper color, must include the complete model and serial number of the unit for which parts are being ordered.

# FUNCTIONAL COMPONENTS

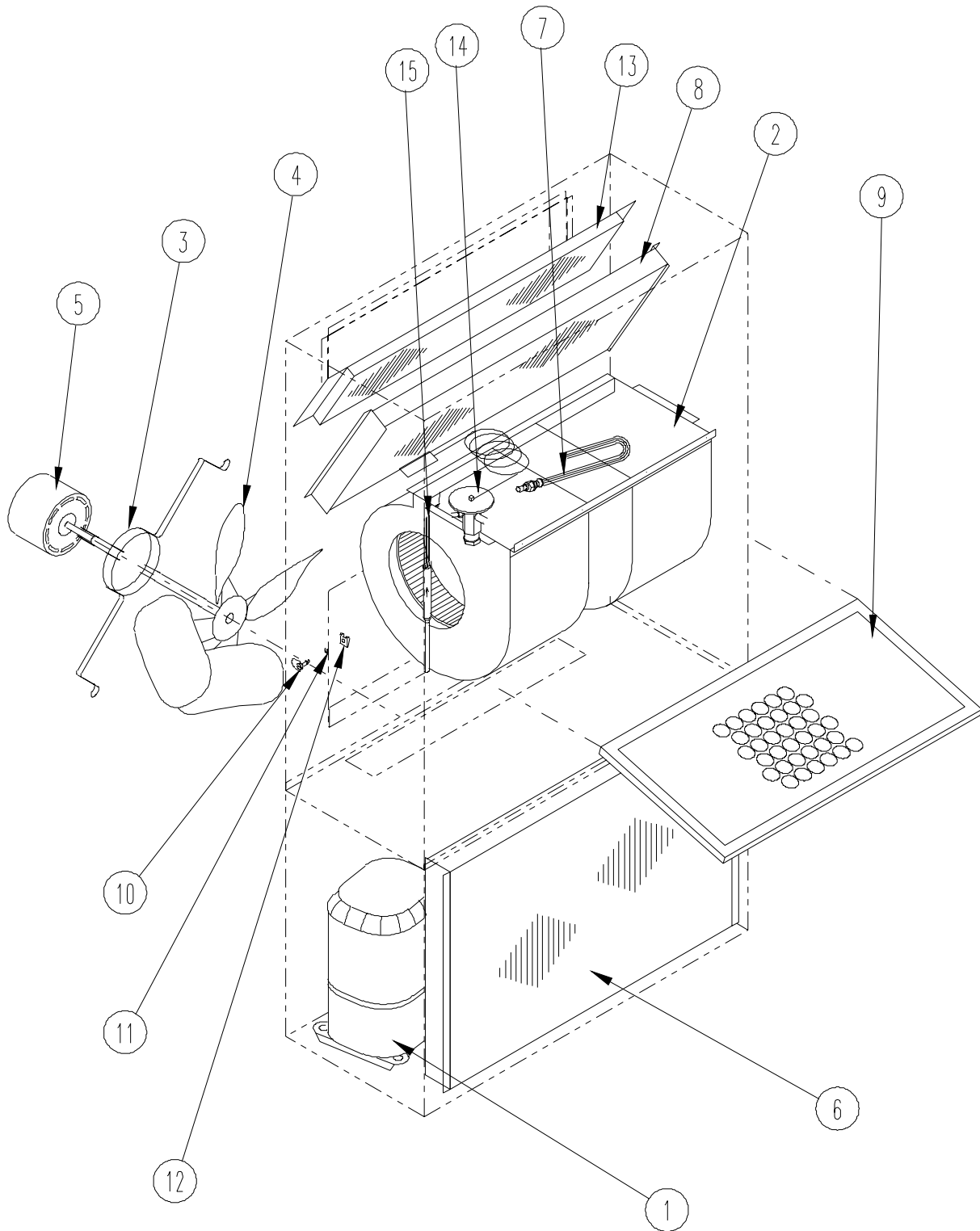

SEXP-228

## FUNCTIONAL COMPONENTS

Drawing No.	Part No.	Description	WL301TA	WL301TB	WL301TN	WL361TA	WL361TB	WL361TN
1	8000-125	Compressor				X		
1	8000-132	Compressor	X					
1	8000-133	Compressor					X	
1	8000-207	Compressor						X
1	8000-135	Compressor		X				
1	8000-210	Compressor			X			
2	S900-179	Blower Assembly	X	X	X	X	X	X
3	8200-001	Fan Motor Mount	X	X	X	X	X	X
4	5151-045	Fan Blade	X	X	X	X	X	X
5	8103-023	Condenser Motor	X	X	X	X	X	X
6	5051-089	Condenser Coil				X	X	X
6	5051-091	Condenser Coil	X	X	X			
7	800-0185	Cooling Capillary Assembly				X	X	X
7	800-0184	Cooling Capillary Assembly	X	X	X			
8	5060-064	Evaporator Coil	X	X	X	X	X	X
9	7004-019	Air Filter 1" Throw-Away	X	X	X	X	X	X
9	7003-031	Air Filter 1" Washable (Optional)	X	X	X	X	X	X
9	7004-026	Air Filter 2" Pleated (Optional)	X	X	X	X	X	X
10	1171-022	1/4" Turn Fastener	X	X	X	X	X	X
11	1171-024	1/4" Turn Retainer	X	X	X	X	X	X
12	1171-023	1/4" Receptacle	X	X	X	X	X	X
NS	1804-0106	High Pressure Switch (Flare)	X	X	X	X	X	X
NS	1804-0107	Low Pressure Switch (Flare)	X	X	X	X	X	X
NS	CMA-6	Low Ambient Control (Flare)	X	X	X	X	X	X
NS	8406-087	Modulating Low Ambient Control 60HZ Å	X	X	X	X	X	X

NS — Not Shown

Å — Optional

# CONTROL PANEL COMPONENTS

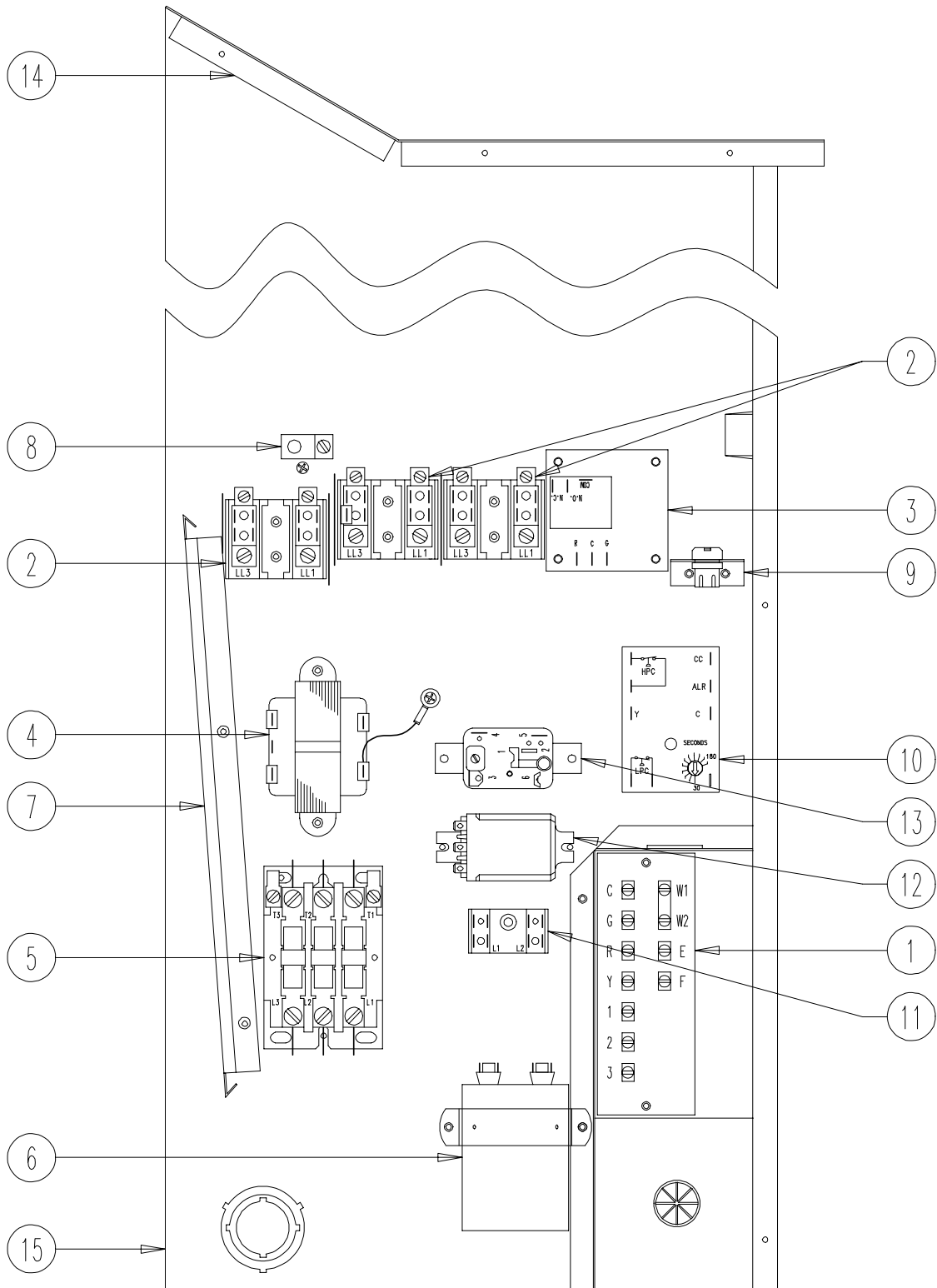

SEXP-248

## CONTROL PANEL COMPONENTS

Drawing			WL301TA	WL301TB	WL301TN	WL361TA	WL361TB	WL361TN
No.	Part No.	Description						
1	8607-020	Low Voltage Terminal Strip	X	X	X	X	X	X
2	8607-013	Terminal Block 2 Pole	2	X	3	2	X	3
2	8607-014	Terminal Block 3 Pole		X			X	
2	134-051	Phenolic Insulator			2			2
3	8201-056	Blower Control	X	X	X	X	X	X
4	8407-034	Transformer	X	X	X	X	X	X
5	8401-007	Compressor Contactor	X			X		
5	8401-002	Compressor Contactor		X	X		X	X
6	8552-048	Compressor Capacitor	X					
6	8552-050	Compressor Capacitor				X		
6	8552-002	Outdoor Motor Capacitor		X	X		X	X
7	135-122	Wire Shield	X	X	X	X	X	X
8	8611-006	Ground Terminal	X	X	X	X	X	X
9	3000-1066	6 Pin Connector	X	X	X	X	X	X
10	8201-087	Compressor Control Module	X	X	X	X	X	X
11	8607-017	Terminal Block (Optional - Shown)	X	X	X	X	X	X
12	8201-074	Inverter Relay	X	X	X	X	X	X
13	8201-062	Alarm Relay	X	X	X	X	X	X
14	117-137	Control Panel Top	X	X	X	X	X	X
15	117-123	Control Panel	X	X	X	X	X	X
NS	4095-131	Wiring Diagram	X			X		
NS	4095-233	Wiring Diagram		X			X	
NS	4095-703	Wiring Diagram			X			X

NS — Not Shown

# BLOWER ASSEMBLY

900-179

Drawing No.	Part No.	Description	
1	5152-051	Housing, Wheel and Cutoff (CW)	X
2	5152-052	Housing, Wheel and Cutoff	X
3	8105-029	Blower Motor (230/208)	X
4	8552-002	Capacitor	X
5	8200-031	Motor Mount	X
6	5451-011	Grommets	6
7	105-870	Back Brace	X
8	104-868	Side Angle	4

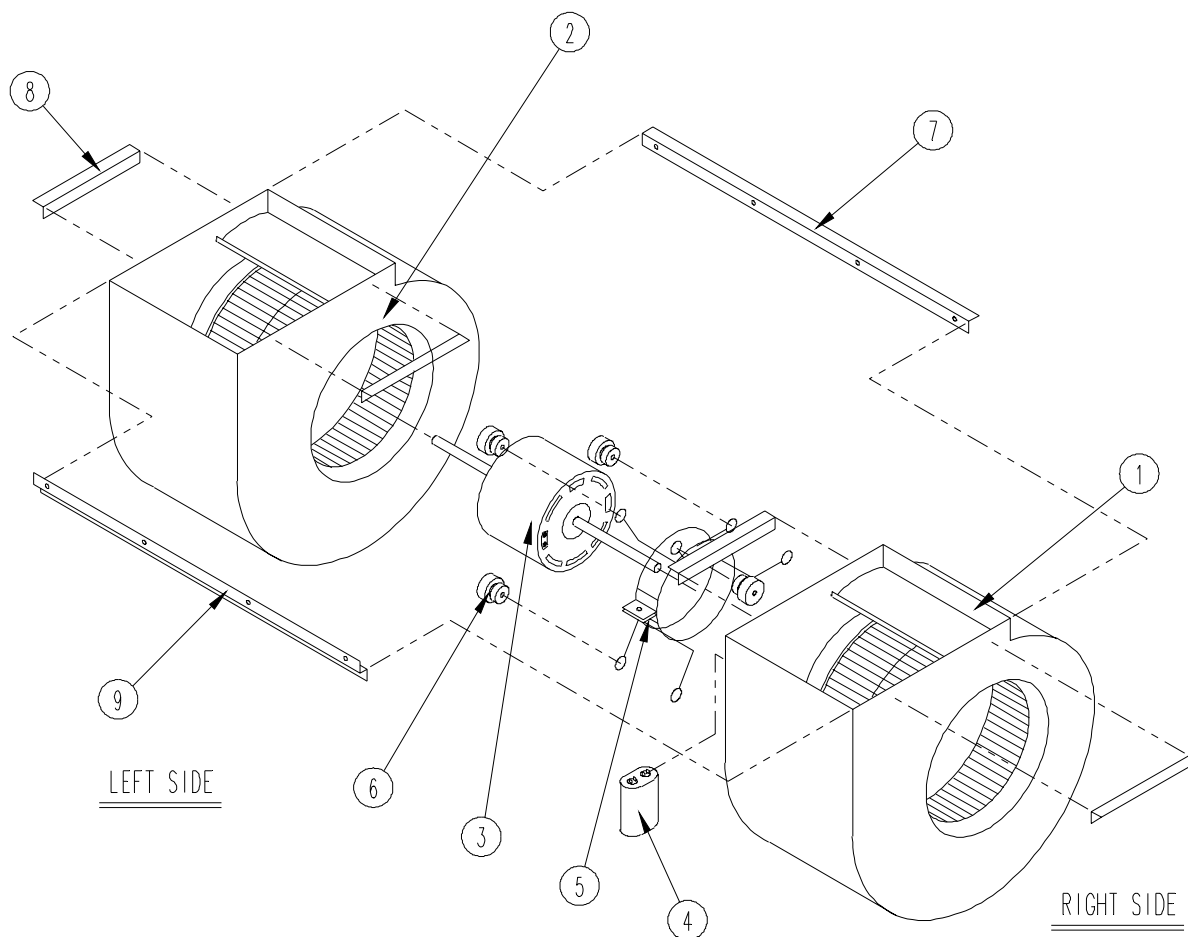

SEXP-161