Replacement Parts Manual

Wall Mounted Package Air Conditioner

Models: WL181, WL241

General Notes

- Revised and/or additional pages may be issued from time to time.
- A complete and current manual consists of pages shown in the following contents section.

Important

- Contact the installing and/or local Bard distributor for all parts requirements. Make sure you have the complete model and serial number available from the unit rating plates.

Contents

Description	Page
Cabinet Components	
• Exploded View	1
• Usage List	2
Functional Components	
• Exploded View	3
• Usage List	4
Control Panel	
• Exploded View	5
• Usage List	6
Blower Assembly	
• Exploded View	7
• Usage List	7



BARD MANUFACTURING COMPANY
Bryan, Ohio 43506

Since 1914...Moving ahead, just as planned.

Manual: 2110-425
File: 2150-004, Tab 16
Date: 01/20/97

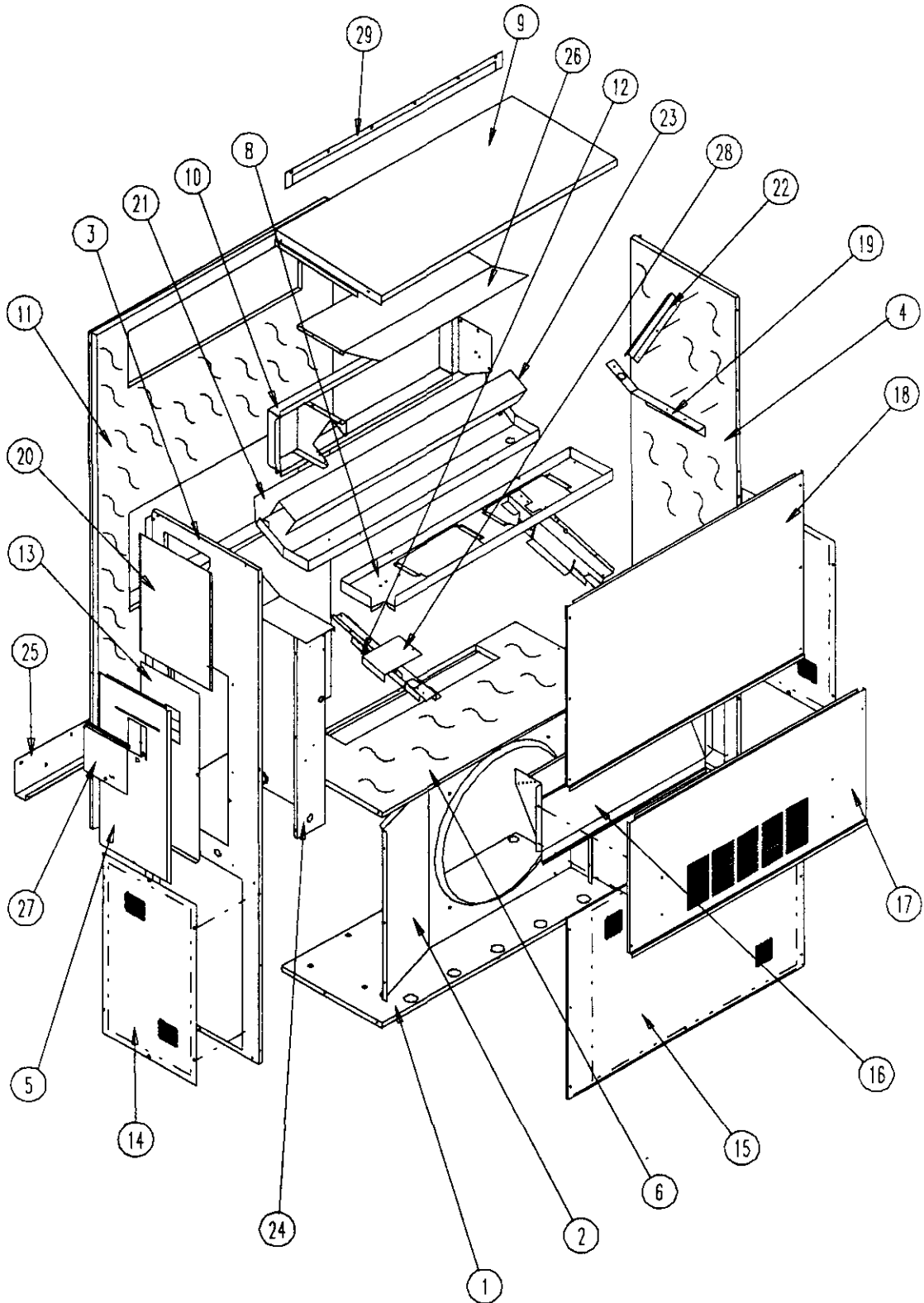

SEXP-255

Cabinet Components

Drawing No.	Part No.	Description	WL181-A	WL241-A, B
1	S127-204	Lower Base	X	X
2	125-023	Fan Shroud	X	X
3	S500-317-* ①	Right Side	X	X
4	S500-318-* ①	Left Side	X	X
5	S553-109-* ①	Control Panel Cover (Outer)	X	X
6	S520Y204	Condenser Partition	X	X
8	121Y190	Blower Partition	X	X
9	S506-137-* ①	Top	X	X
10	S111Y032	Outlet Airframe Assembly	X	X
11	S508-097	Back	X	X
12	113Y195	Filter Bracket	2	2
13	S132-104	Control Panel Cover (Inner)	X	X
14	118-028-* ①	Side Grille	2	2
15	118-030-* ①	Condenser Grille	X	X
16	962019	Fresh Air Damper Assembly	X	X
17	S552-213-* ①	Service Door	X	X
18	S514-076-* ①	Upper Front	X	X
19	105Y850	Right Side Support	X	X
20	S143-034-* ①	Right Side Cover Plate (Outer)	X	X
21	S123-092	Drain Pan	X	X
22	147-044	Left Evaporator Support	X	X
23	137-195	Bottom Evaporator Fill	X	X
24	Control Panel Assembly	See Control Panel Assembly Drawing and Parts List	X	X
25	113-140	Bottom Mounting Bracket	X	X
26	135Y127	Heat Shield	X	X
7	S153-218-* ①	Disconnect Access Door	X	X
28	137-259	Fill Plate	X	X
29	113-141-* ①	Top Rain Flashing	X	X

① **NOTE:** Exterior cabinet parts are manufactured with various paint color options. To insure that you receive the proper paint color, you must include the complete model and serial number of the unit for which cabinet parts are being ordered.

Functional Components

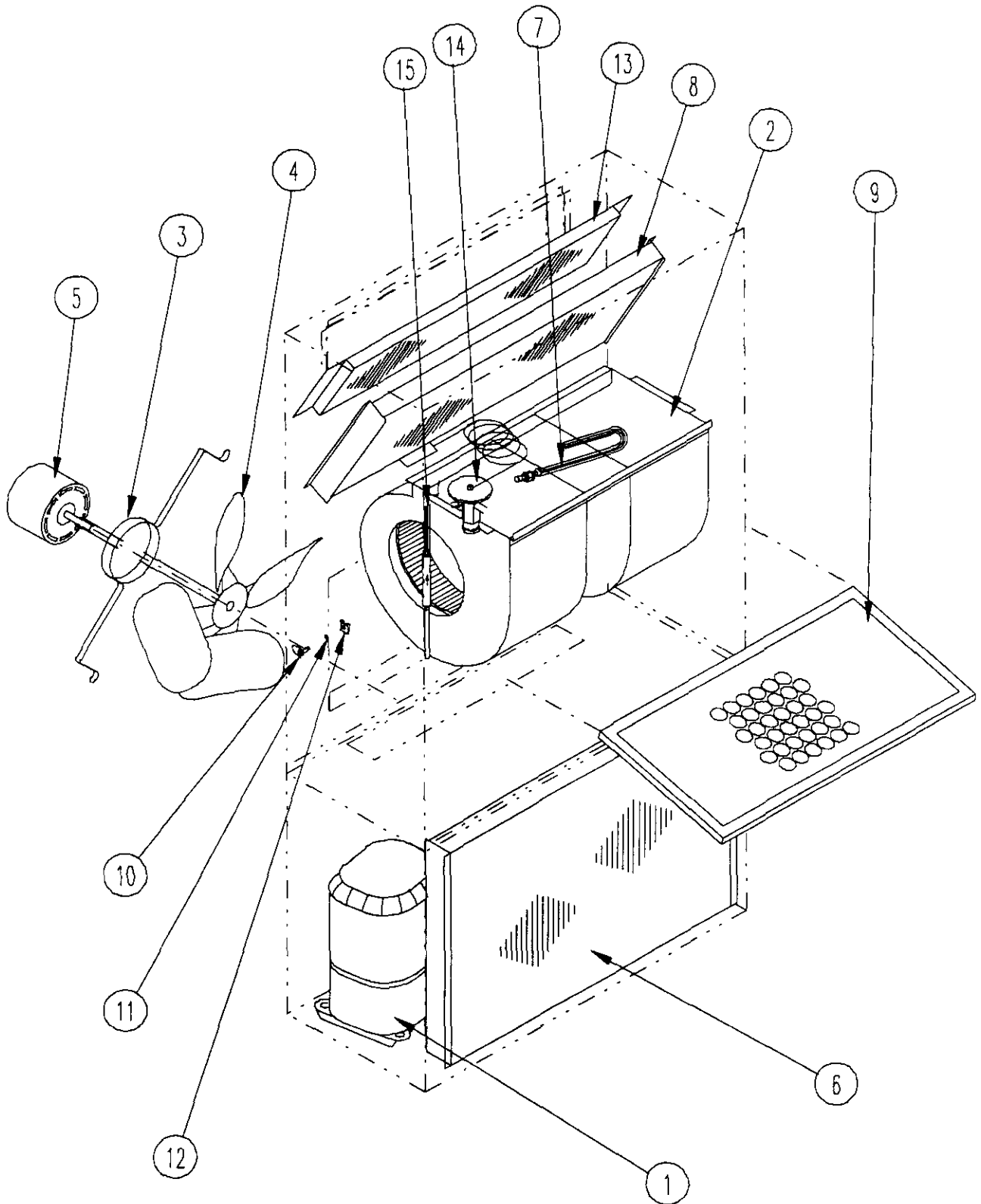

SEXP-228

Functional Components

Dwg. No.	Part No.	Description	WL181-A	WL241-A	WL241-B
1	8000-139	Compressor	X		
1	8000-140	Compressor		X	
1	8000-141	Compressor			X
2	S900-181	Blower Assembly	X	X	X
3	8200-001	Fan Motor Mount	X	X	X
4	5151-033	Fan Blade	X	X	X
5	8103-016	Condensor Motor	X	X	X
6	5051-092	Condensor Coil	X	X	X
7	800-0197	Cooling Capillary Assembly	X		
7	800-0198	Cooling Capillary Assembly		X	X
8	5060-066	Evaporator Coil		X	X
8	5060-067	Evaporator Coil	X		
9	7004-011	Air Filter 1" Throw-Away	X	X	X
9	7003-032	Air Filter 1" Washable ①	X	X	X
9	7004-025	Air Filter 2" Pleated ①	X	X	X
10	1171-022	1/4" Turn Fastener	X	X	X
11	1171-024	1/4" Turn Retainer	X	X	X
12	1171-023	1/4" Receptacle	X	X	X
NS	8406-055	High Pressure Switch (Solder) ①	X	X	X
NS	8406-061	Low Pressure Switch (Solder) ①	X	X	X
NS	8406-088	Low Ambient Control (Solder) ①	X	X	X
NS	1804-0106	High Pressure Switch (Flare) ①	X	X	X
NS	1804-0107	Low Pressure Switch (Flare) ①	X	X	X
IS	1804-0108	Low Ambient Control (Flare) ①	X	X	X

NS = Not Shown

① = Optional on these models

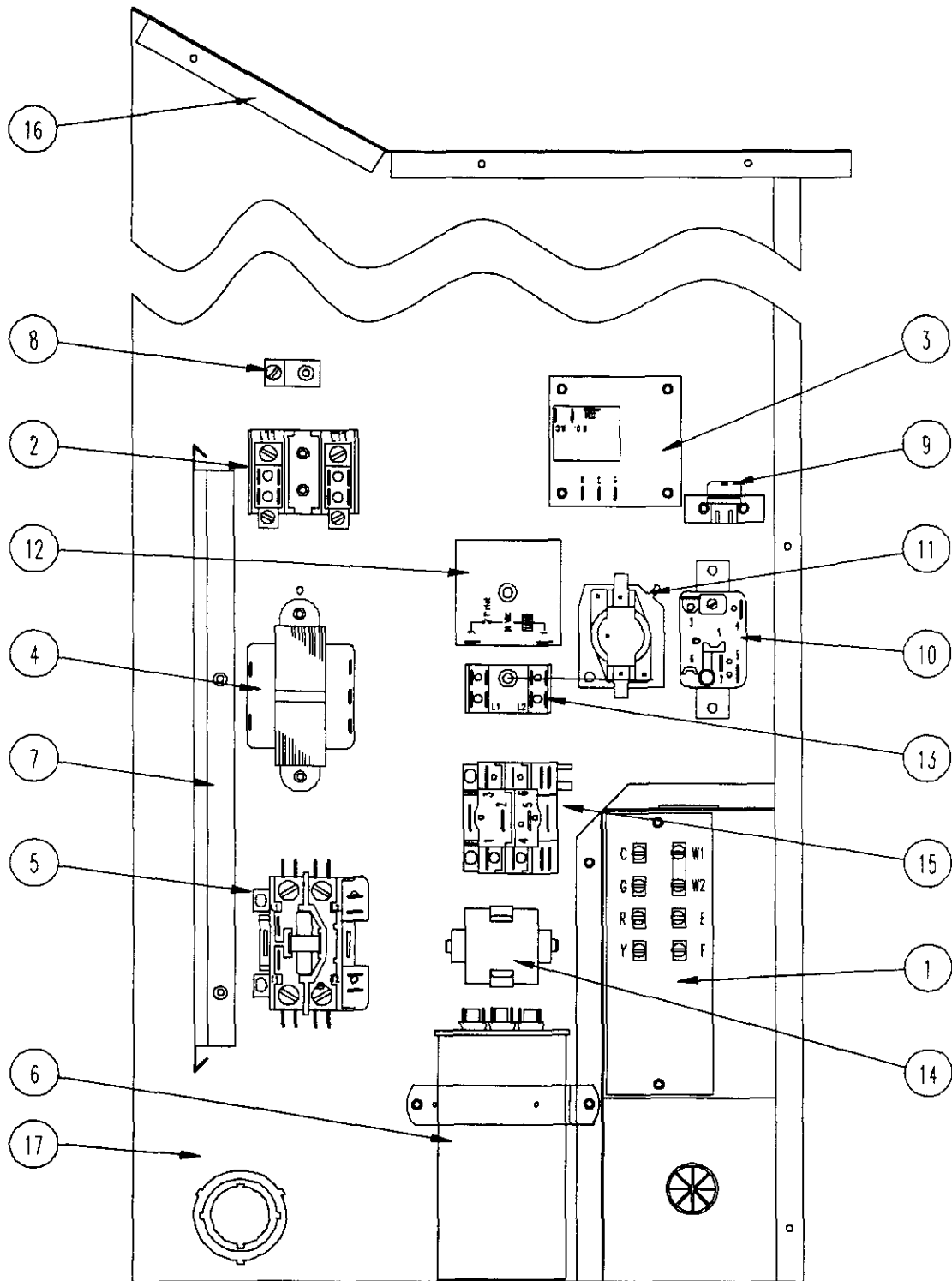

SEXP-229

Control Panel

Drawing			WL181-A	WL241-A	WL241-B
No.	Part No.	Description			
1	8607-020	Low Voltage Terminal Strip	X	X	X
2	8607-013	Terminal Block 2 Pole	X	X	
2	8607-014	Terminal Block 3 Pole			X
3	8201-056	Blower Control	X	X	X
4	8407-034	Transformer	X	X	X
5	8401-007	Compressor Contactor	X	X	
5	8401-002	Compressor Contactor			X
6	8552-046	Compressor Capacitor	X		
6	8552-047	Compressor Capacitor		X	
6	8552-002	Outdoor Motor Capacitor			X
7	135-122	Wire Shield	X	X	X
8	8611-006	Ground Terminal	X	X	X
9	3000-968	6 Pin Connector	X	X	X
10	8201-034	Lockout Relay (Optional)	X	X	X
11	8201-065	Low Pressure Bypass (TDR) (Optional)	X	X	X
12	8201-050	Compressor TDR (Optional)	X	X	X
12	8201-067	Compressor TDR Adj (Optional)	X	X	X
13	8201-062	Alarm Relay (Optional)	X	X	X
13	8607-017	Terminal Block (Optional) (Shown)	X	X	X
14	8551-005	Start Device (PTCR) (Optional)	X	X	X
16	117-137	Control Panel Top	X	X	X
17	117-123	Control Panel	X	X	X
	4095-111	Wiring Diagram	X	X	
	4095-211	Wiring Diagram			X

Blower Assembly

Drawing No.	Part No.	Description	900-181
1	5152-069	Housing, Wheel and Cutoff (CW)	X
2	5152-070	Housing, Wheel and Cutoff	X
3	8102-011	Blower Motor (230/208)	X
4	8552-002	Capacitor	X
5	8200-039	Motor Mount	X
6	5451-011	Grommets	6
7	105-869	Back Brace	X
8	105-868	Side Angle	4
9	103-400	Front Brace	X

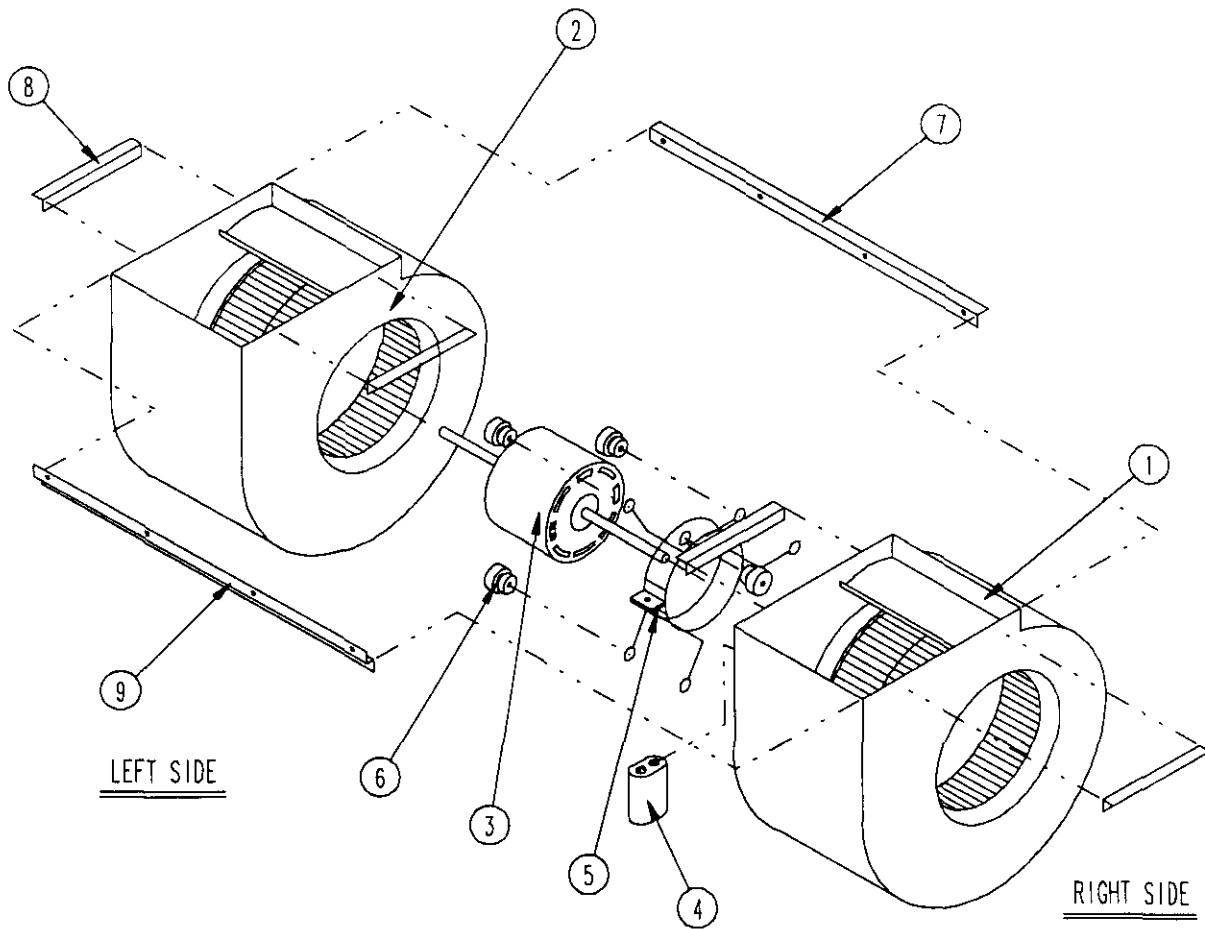

SEXP-181