

Replacement Parts Manual

Wall Mounted Cabinet Air Conditioner

Model: CT241

General Notes

- Revised and/or additional pages may be issued from time to time.
- A complete and current manual consists of pages shown in the following contents section.

Important

- Contact the installing and/or local Bard distributor for all parts requirements. Make sure you have the complete model and serial number available from the unit rating plates.

Contents

Description	Page
Cabinet Components	
♦ Exploded View	1
♦ Usage List	2
Functional Components	
♦ Exploded View	3
♦ Usage List	4
Control Panel	
♦ Exploded View	5
♦ Usage List	6



BARD MANUFACTURING COMPANY
Bryan, Ohio 43506

Since 1914...Moving ahead, just as planned.

Manual: 2110-428C
Supersedes: 2110-428B
File: Volume II, Tab 15
Date: 08-10-99

Cabinet Components

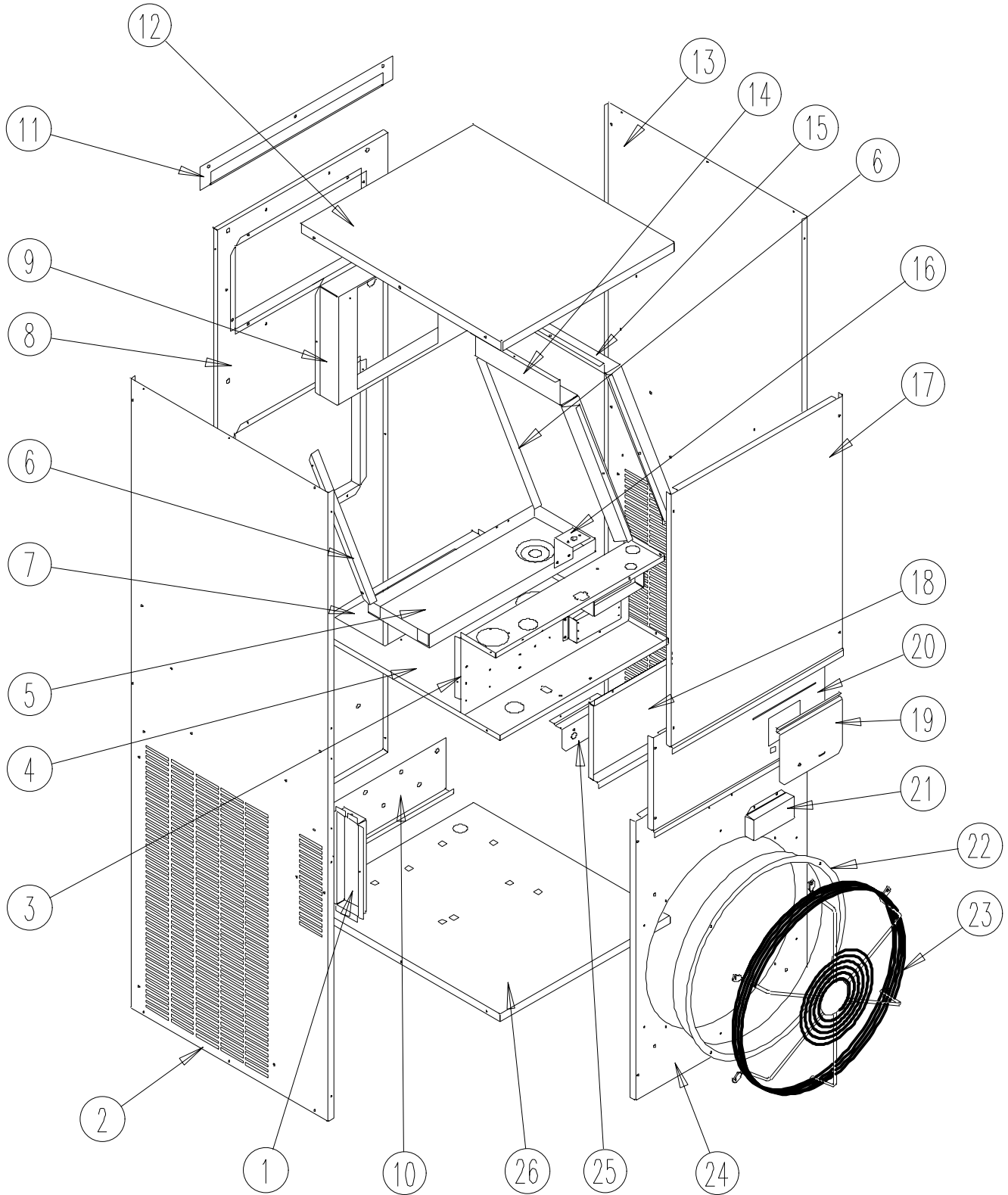

SEXP-279

This Exploded View references Table on Page 2

Cabinet Components

Drawing No.	Part No.	Description	CT241-A0Z	CT241-A02	CT241-A04	CT241-B0Z	CT241-B03
1	140-256	Bulb Support Box	X	X	X	X	X
2	501-350-* (1)	Left Side	X	X	X	X	X
3	Control Panel	(See Control Panel Assembly Drawing & Parts List)					
4	520-319	Condenser Partition	X	X	X	X	X
5	123-097	Drain Pan	X	X	X	X	X
6	104-1014	Support Angle	2	2	2	2	2
7	536-389	Exhaust Blank Off Plate	X	X	X	X	X
8	508-147	Back Assembly	X	X	X	X	X
9	110-051	Supply Box	X	X	X	X	X
10	112-241	Bottom Mounting Bracket	X	X	X	X	X
11	113-244-* (1)	Rain Flashing	X	X	X	X	X
12	507-212-* (1)	Top	X	X	X	X	X
13	501-349-* (1)	Right Side	X	X	X	X	X
14	164-558	Bottom Wire Channel	X	X	X	X	X
15	164-559	Top Wire Channel	X	X	X	X	X
16	113-142	Expansion Valve Mounting Bracket	X	X	X	X	X
17	553-301-* (1)	Blower Door	X	X	X	X	X
18	132-152	Inner Control Panel Door	X	X	X	X	X
19	153-303-* (1)	Circuit Breaker Door	X	X	X	X	X
20	553-302-* (1)	Outer Control Panel Door	X	X	X	X	X
21	143-062-* (1)	Service Port Cover	X	X	X	X	X
22	167-021-* (1)	Fan Venturi	X	X	X	X	X
23	7051-044	Fan Grille	X	X	X	X	X
24	153-300-* (1)	Condenser Access Panel	X	X	X	X	X
25	113-240-* (1)	Service Port Mounting Plate	X	X	X	X	X
26	126-291	Base	X	X	X	X	X

(1) Exterior cabinet parts are manufactured with various color options. To insure that you receive the proper paint color, you must include the complete model and serial number of the unit for which cabinets parts are being ordered.

This Table references Exploded View on Page 1

Functional Components

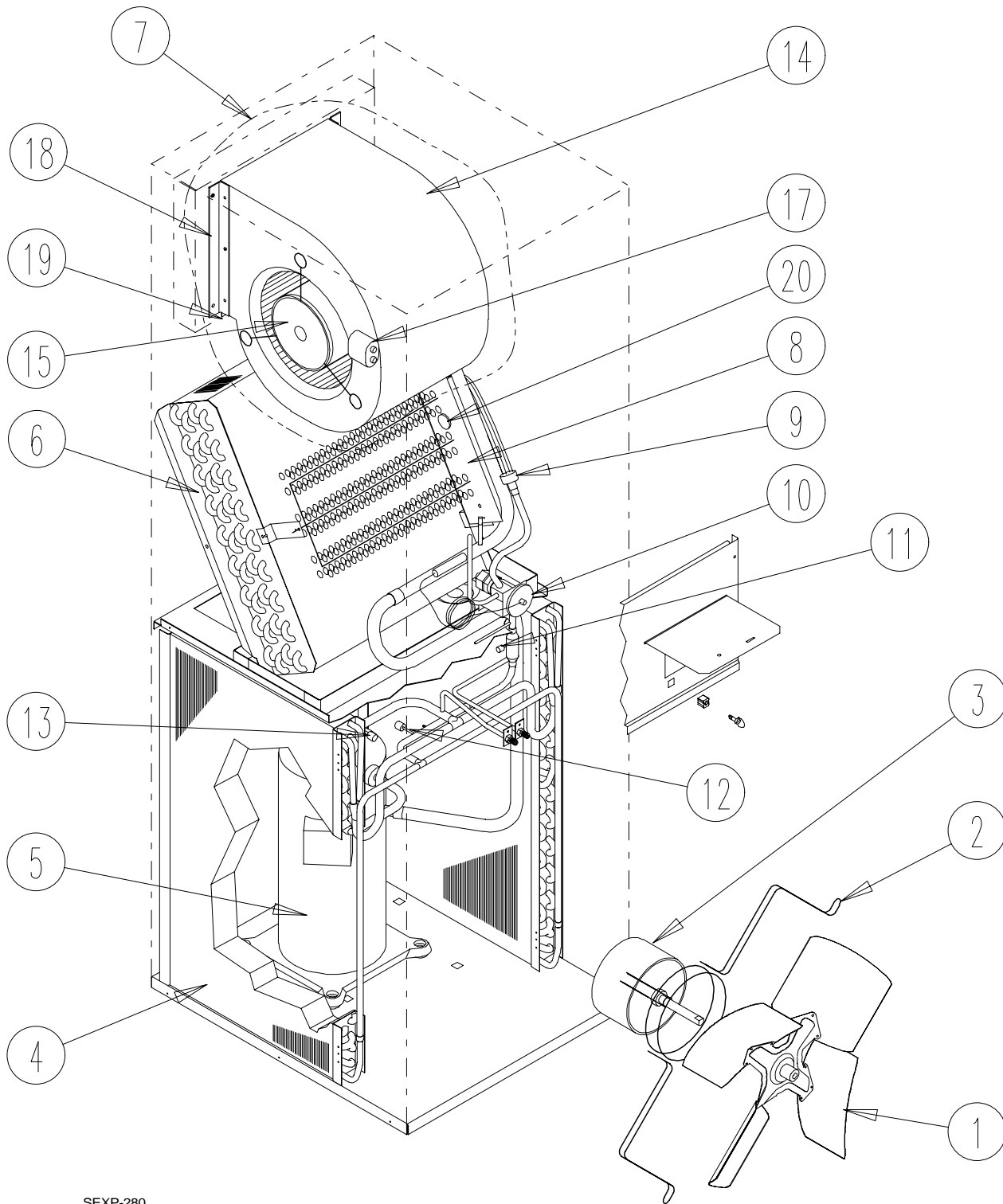

SEXP-280

This Exploded View references Table on Page 4

Functional Components

Drawing No.	Part No.	Description	CT241-A0Z	CT241-A02	CT241-A04	CT241-B0Z	CT241-B03
1	5151-053	Fan Blade 16"	X	X	X	X	X
2	8200-042	Motor Mount – Fan	X	X	X	X	X
3	8101-018	Motor Fan	X	X	X	X	X
4	5051-105	Condenser Coil	2	2	2	2	2
5	8000-171	Compressor ZR24K3-PFV	X	X	X		
5	8000-201	Compressor ZR24K3-TF5				X	X
6	5060-096	Evaporator Coil	X	X	X	X	X
7	900-229	Complete Blower Assembly	X	X	X	X	X
8	8604-111	2.0 KW Heat Strip 240-60-1		X			
8	8604-112	3.0 KW Heat Strip 240-60-3					X
8	8604-113	4.0 KW Heat Strip 240-60-1			X		
9	5625-007	Distributor	X	X	X	X	X
10	5651-148	Expansion Valve	X	X	X	X	X
11	8406-061	Low Pressure Switch	X	X	X	X	X
12	CMA-6 *	Low Ambient Control	X	X	X	X	X
13	8406-055	High Pressure Switch	X	X	X	X	X
14	5152-089	Blower Housing and Wheel	X	X	X	X	X
15	8104-013	Motor – Blower	X	X	X	X	X
17	8552-019	Capacitor 5 / 440V	X	X	X	X	X
18	104-1015	Angle – Side	2	2	2	2	2
19	104-1016	Angle – Bottom	X	X	X	X	X
20	8402-110	Limit Control L120-3.0		1	1		
20	8402-111	Limit Control L115–3.5					1

* Subject to equipment parts discount

This Table references Exploded View on Page 3

Control Panel

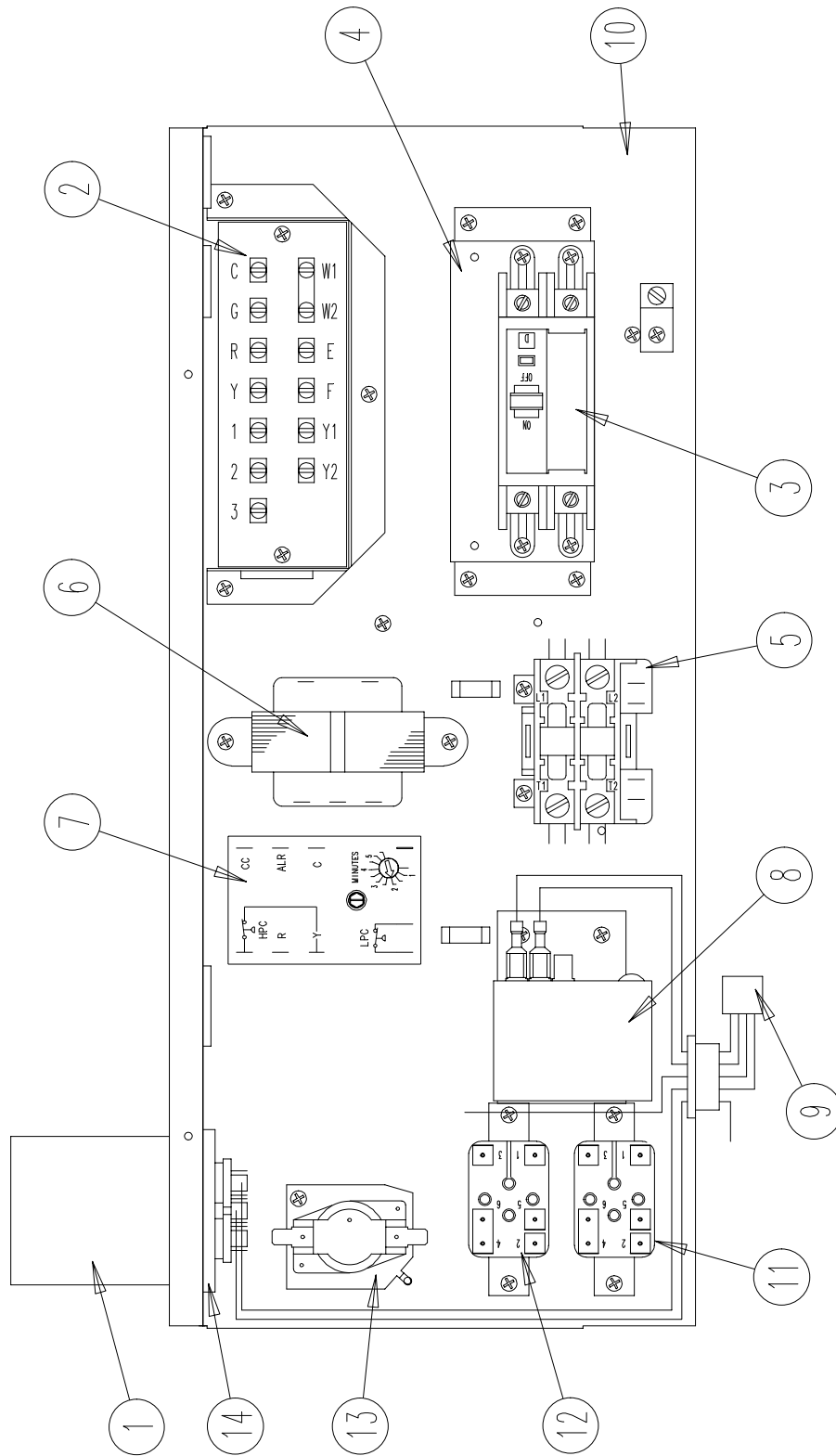

SEXP-282

This Exploded View references Table on Page 6

Control Panel

Drawing No.	Part No.	Description	CT241-A0Z	CT241-A02	CT241-A04	CT241-B0Z	CT241-B03
1	8552-050	Capacitor 40+5 / 370V	X	X	X		
1	8552-002	Capacitor 5 / 370V				X	X
2	8607-024	Terminal Board	X	X	X	X	X
3	8615-037	Circuit Breaker 30A	X	X	X		
3	8615-054	Circuit Breaker 20A				X	X
4	140-254	Circuit Breaker Mounting Plate	X	X	X	X	X
5	8401-006	Compressor Contactor 2 Pole	X	X	X		
5	8401-002	Compressor Contactor 3 Pole				X	X
6	8407-035	Transformer 50 VA	X	X	X	X	X
7	8201-088	Compressor Control Module	X	X	X	X	X
8	8408-036	Outdoor Thermostat	X	X	X	X	X
9	3000-1077	Outdoor Motor Wire Harness	X	X	X	X	X
10	516-205	Control Panel	X	X	X	X	X
11	8201-062	Alarm Relay	X	X	X	X	X
12	8201-009	Relay – Blower	X	X	X	X	X
13	8201-057	Time Delay Relay H30-75 C1-40		X	X		
13	8201-058	Time Delay Relay H1-30 C45-70					X
14	112-210	Capacitor Mounting Plate				X	X
NS	4104-100	Wiring Diagram 230/208-60-1 0 KW	X				
NS	4104-110	Wiring Diagram 230/208-60-1 2 KW		X			
NS	4104-120	Wiring Diagram 230/208-60-1 4 KW			X		
NS	4104-200	Wiring Diagram 230/208-60-3 0 KW				X	
NS	4104-210	Wiring Diagram 230/208-6-3 3 KW					X

NS = Not Shown

This Table references Exploded View on Page 5