REPLACEMENT PARTS MANUAL

WALL MOUNTED PACKAGE AIR CONDITIONER

Models: **WL182, WL242**

General Notes

- Revised and/or additional pages may be issued from time to time.
- A complete and current manual consists of pages shown in the following contents section.

Important

- Contact the installing and/or local Bard distributor for all parts requirements. Make sure you have the complete model and serial number available from the unit rating plates.

Contents

Description	Page
Cabinet Components	
♦ Exploded View	2
♦ Usage List	3
Functional Components	
♦ Exploded View	4
♦ Usage List	5
Control Panel	
♦ Exploded View	6
♦ Usage List	7
Blower Assembly	
♦ Exploded View	8
♦ Usage List	8



Climate Control Solutions

Bard Manufacturing Company, Inc.
Bryan, Ohio 43506
Since 1914...Moving ahead, just as planned.

Manual: 2110-444E
Supersedes: 2110-444D
File: Tab 16
Date: 11-15-07

CABINET COMPONENTS

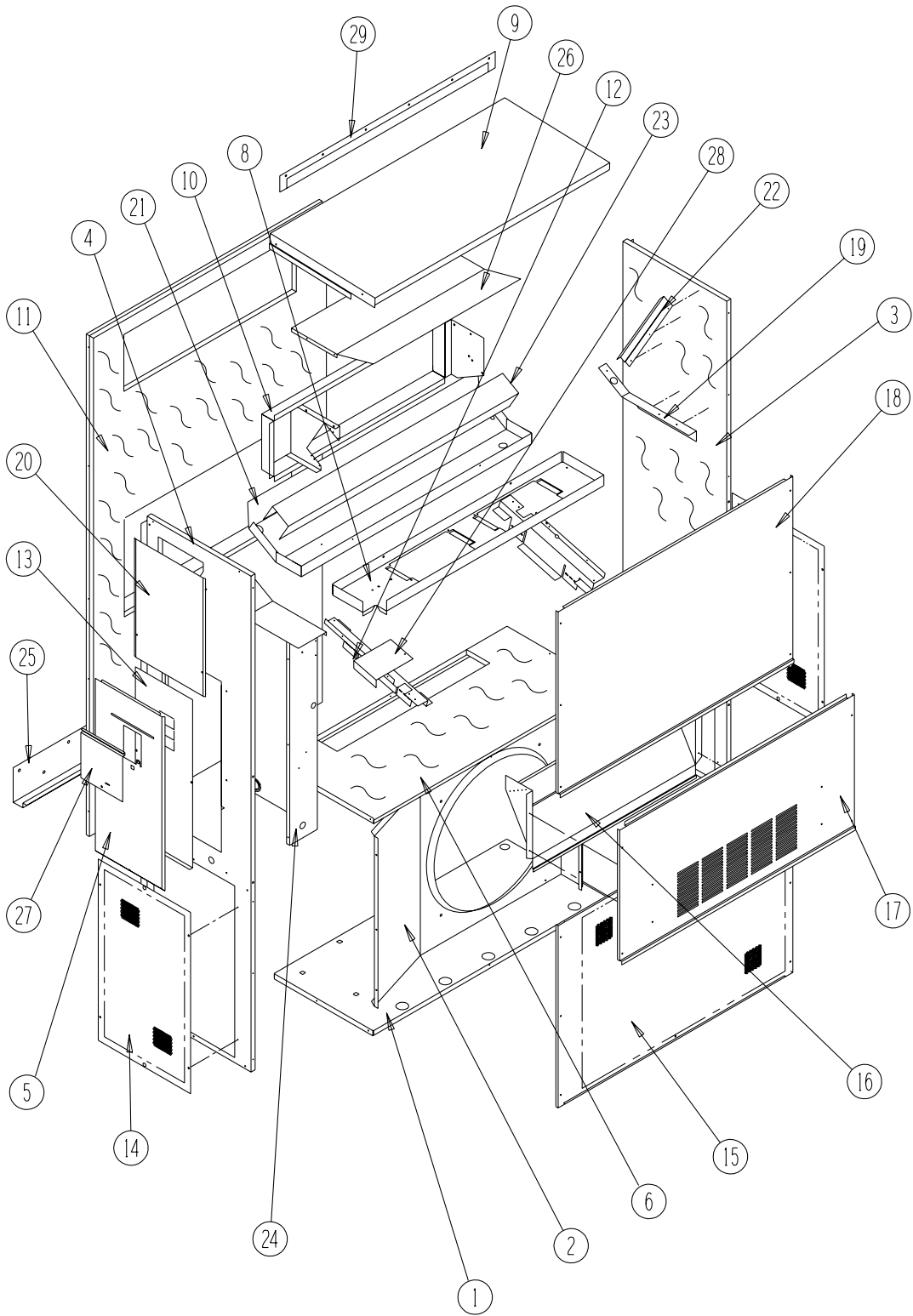

SEXP-255

CABINET COMPONENTS

Dwg. No.	Part Number	Description	WL182-A	WL242-A, -B, -D	WL242-F
1	S127-204	Lower Base	X	X	X
2	125-023	Fan Shroud	X	X	X
3	S500-317-* ①	Right Side	X	X	X
3	S500-458-* ②	Right Side	X	X	
4	S500-318-* ①	Left Side	X	X	X
4	S500-459-* ②	Left Side	X	X	
5	S533-109-* ①	Control Panel Cover (Outer)	X	X	X
5	S533-184-* ②	Control Panel Cover (Outer)	X	X	
6	S521Y204	Condenser Partition	X	X	X
8	121Y336	Blower Partition	X	X	X
9	S506-137-* ①	Top	X	X	X
9	S506-270-* ②	Top	X	X	
10	S111Y032	Outlet Air Frame Assembly	X	X	X
11	S508-097	Back	X	X	X
11	S508-208 ②	Back	X	X	
12	113Y195	Filter Bracket	2	2	2
13	S132-104	Control Panel Cover (Inner)	X	X	X
14	118-056-* ①	Side Grille	2	2	2
14	118-060-* ②	Side Grille	2	2	
15	118-051-* ①	Condenser Grille	X	X	X
15	118-071-* ②	Condenser Grille	X	X	
16	BFAD-2	Fresh Air Damper Assembly	X	X	X
17	S552-213-* ①	Service Door	X	X	X
17	S552-436-* ②	Service Door	X	X	
18	S514-076-* ①	Upper Front	X	X	X
18	S514-155-* ②	Upper Front	X	X	
19	105Y850	Side Support	X	X	X
20	S143-034-* ①	Right Side Cover Plate (Outer)	X	X	X
20	S143-103-* ②	Right Side Cover Plate (Outer)	X	X	
21	S123-092	Drain Pan	X	X	X
22	147-044	Left Evaporator Support	X	X	X
23	137-195	Bottom Evaporator Fill	X	X	X
24	Control Panel Assembly	See Control Panel Assembly Drawing and Parts List Assembly	X	X	X
25	113-140	Bottom Mounting Bracket	X	X	X
26	135Y127	Heat Shield	X	X	X
27	S153-218-* ①	Disconnect Access Door	X	X	X
27	S153-387-* ②	Disconnect Access Door	X	X	
28	137-259	Fill Plate	X	X	X
29	113-141-* ①	Top Rain Flashing	X	X	X
NS	S536-176	Cond. Part. Block Off Plate	X	X	X

① NOTE: Exterior cabinet parts are manufactured with various paint color options. To insure that you receive the proper paint color, you must include the complete model and serial number of the unit for which cabinet parts are being ordered.

② NOTE: Exterior cabinet parts are manufactured from aluminum Code "A".

FUNCTIONAL COMPONENTS

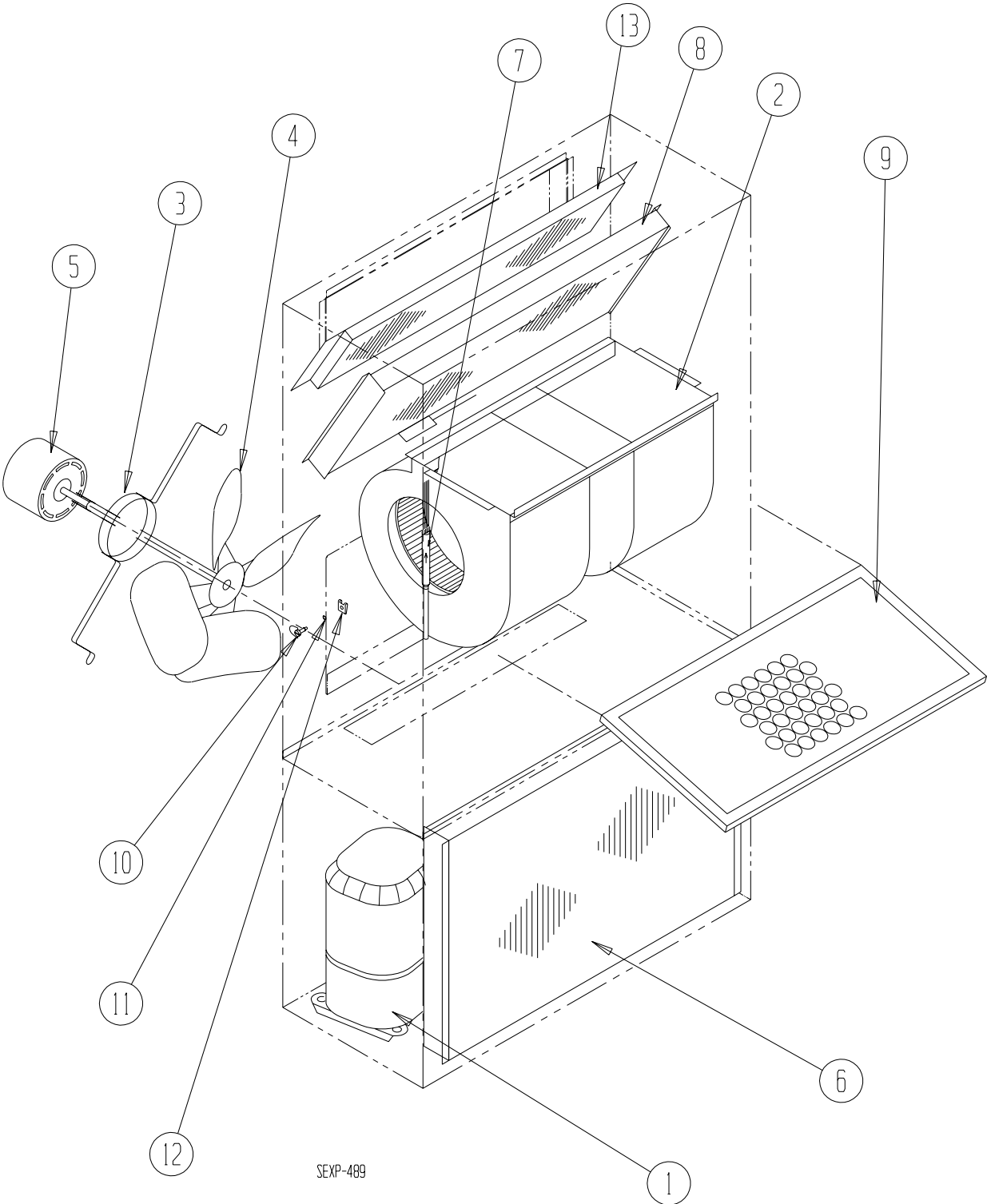

SEXP-489

FUNCTIONAL COMPONENTS

Dwg. No.	Part No.	Description	WL182-A	WL242-A	WL242-D	WL242-B	WL242-F
1	8000-139	Compressor	X				
1	8000-140	Compressor		X			
1	8000-141	Compressor				X	
1	8000-142	Compressor					X
1	8000-143	Compressor			X		
2	S900-248	Blower Assembly	X	X	X	X	X
3	8200-001	Fan Motor Mount	X	X	X	X	X
4	5151-033	Fan Blade	X	X	X	X	X
5	8103-016	Condensor Motor	X	X	X	X	X
6	5051-092BX	Condensor Coil	X	X	X	X	X
7	800-0197	Cooling Capillary Assembly	X				
7	800-0198	Cooling Capillary Assembly		X	X	X	X
8	5060-066BX	Evaporator Coil		X	X	X	X
8	5060-067BX	Evaporator Coil	X				
9	7004-011	Air Filter 1" Throw-Away	X	X	X	X	X
9	7003-032	Air Filter 1" Washable ①	X	X	X	X	X
9	7004-025	Air Filter 2" Pleated ①	X	X	X	X	X
10	1171-022	1/4" Turn Fastener	X	X	X	X	X
11	1171-024	1/4" Turn Retainer	X	X	X	X	X
12	1171-023	1/4" Receptacle	X	X	X	X	X
NS	1804-0106	High Pressure Switch (Flare) ①	X	X	X	X	X
NS	1804-0107	Low Pressure Switch (Flare) ①	X	X	X	X	X
NS	CMA-6	Low Ambient Control (Flare) ①	X	X	X	X	X

NS = Not Shown

① = Optional on these models

CONTROL PANEL

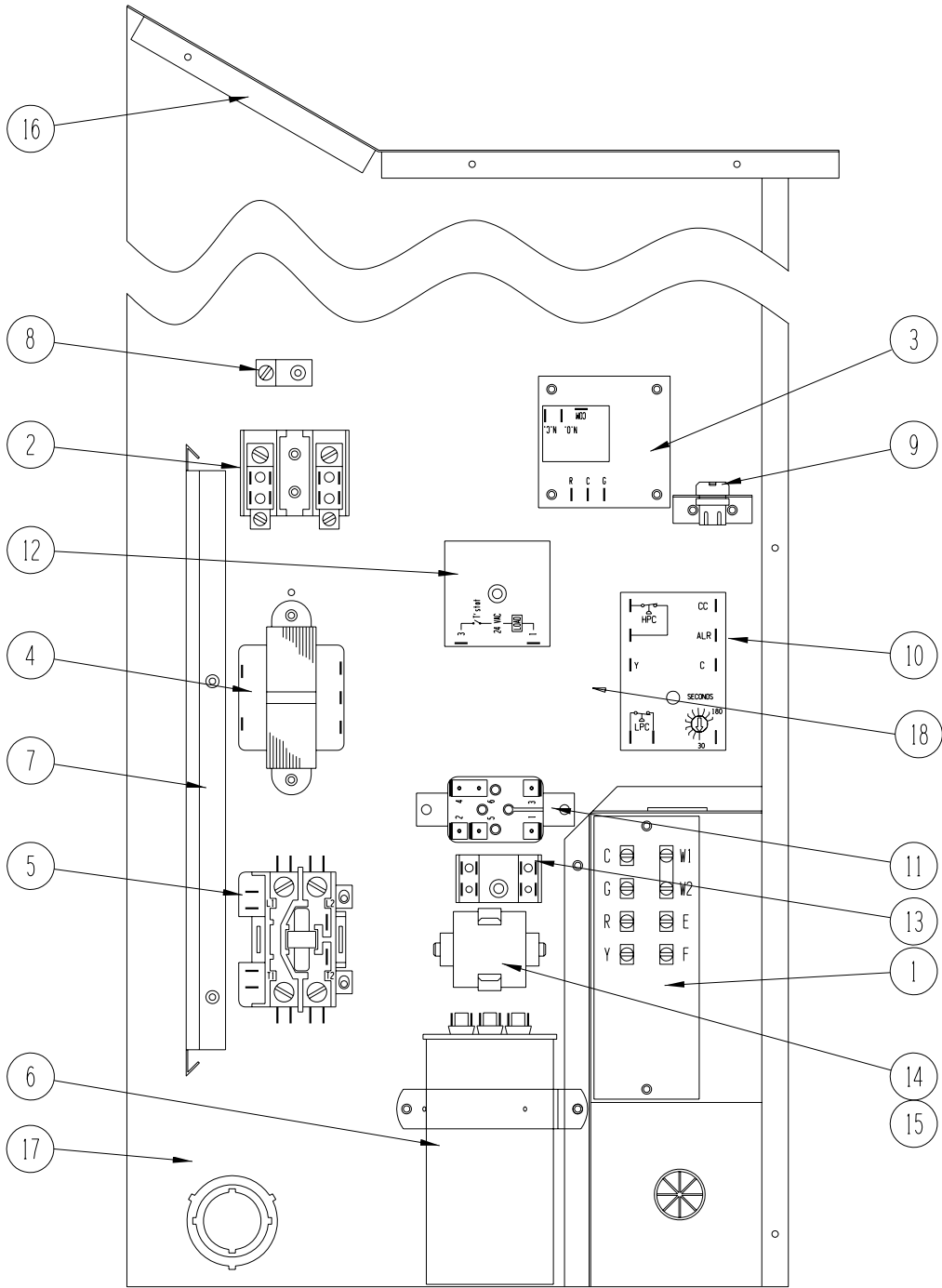

SEXP-323

CONTROL PANEL

Drawing No.	Part No.	Description	WL182-A	WL242-A, WL242-D	WL242-B	WL242-F
1	8607-020	Low Voltage Terminal Strip	X	X	X	X
2	8607-013	Terminal Block 2 Pole	X	X		2
2	8607-014	Terminal Block 3 Pole			X	
3	8201-056	Blower Control	X	X	X	X
4	8407-034	Transformer	X	X	X	X
5	8401-007	Compressor Contactor	X	X		
5	8401-002	Compressor Contactor			X	X
6	8552-046	Compressor Capacitor	X			
6	8552-047	Compressor Capacitor		X		
6	8552-002	Outdoor Motor Capacitor			X	X
7	135-122	Wire Shield	X	X	X	X
8	8611-006	Ground Terminal	X	X	X	X
9	3000-968	6-Pin Connector	X	X	X	X
10	8201-088	Compressor Control Module (Opt.)	X	X	X	X
11	8201-062	Alarm Relay (Optional)	X	X	X	X
12	8201-050	Compressor TDR (Optional)	X	X	X	X
13	8607-017	Terminal Block (Optional) (Shown)	X	X	X	X
14	8551-004	Start Device (PTCR) (Optional)	X	X	X	X
16	117Y137	Control Panel Top	X	X	X	X
17	117Y123	Control Panel	X	X	X	X
NS	4095-130	Wiring Diagram	X	X		
NS	4095-228	Wiring Diagram			X	
NS	4095-621	Wiring Diagram				X

NS = Not Shown

BLOWER ASSEMBLY

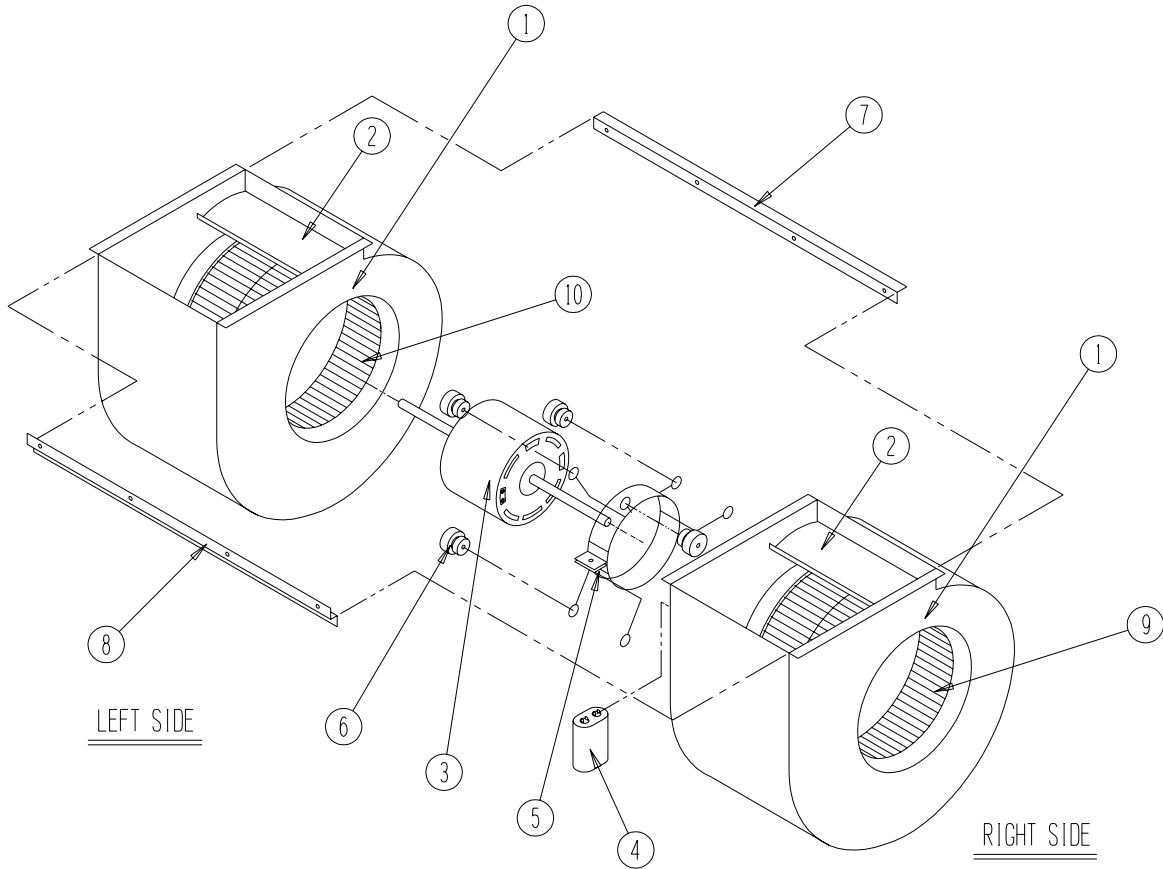

SEXP-346

Drawing No.	Part No.	Description	S900-248
1	151-115	Housing	X
2	144-183	Cutoff	X
3	8102-011	Blower Motor (230/208)	X
4	8552-002	Capacitor	X
5	8200-031	Motor Mount	X
6	5451-011	Grommets	6
7	105-1061	Back Brace	X
8	103-435	Front Brace	X
9	5152-092	Wheel 9-6 CW	X
10	5152-093	Wheel 9-6 CCW	X