REPLACEMENT PARTS MANUAL

WALL MOUNTED PACKAGE AIR CONDITIONER

MODEL: WE253-D
WE253-F

General Notes

- Revised and/or additional pages may be issued from time to time.
- A complete and current manual consists of pages shown in the following contents section.

Important

- Contact the installing and/or local Bard distributor for all parts requirements. Make sure you have the complete model and serial number available from the unit rating plates.

Contents

Description	Page
Cabinet Components	
♦ Exploded View	2
♦ Usage List	3
Functional Components	
♦ Exploded View	4
♦ Usage List	5
Control Panel	
♦ Exploded View	6
♦ Usage List	7
Blower Assembly	
♦ Exploded View	8
♦ Usage List	8



Climate Control Solutions

Bard Manufacturing Company, Inc.
Bryan, Ohio 43506

Since 1914...Moving ahead, just as planned.

Manual: 2110-448B
Supersedes: 2110-448A
File: 2150-004 Tab 16
Date: 10-22-10

CABINET COMPONENTS

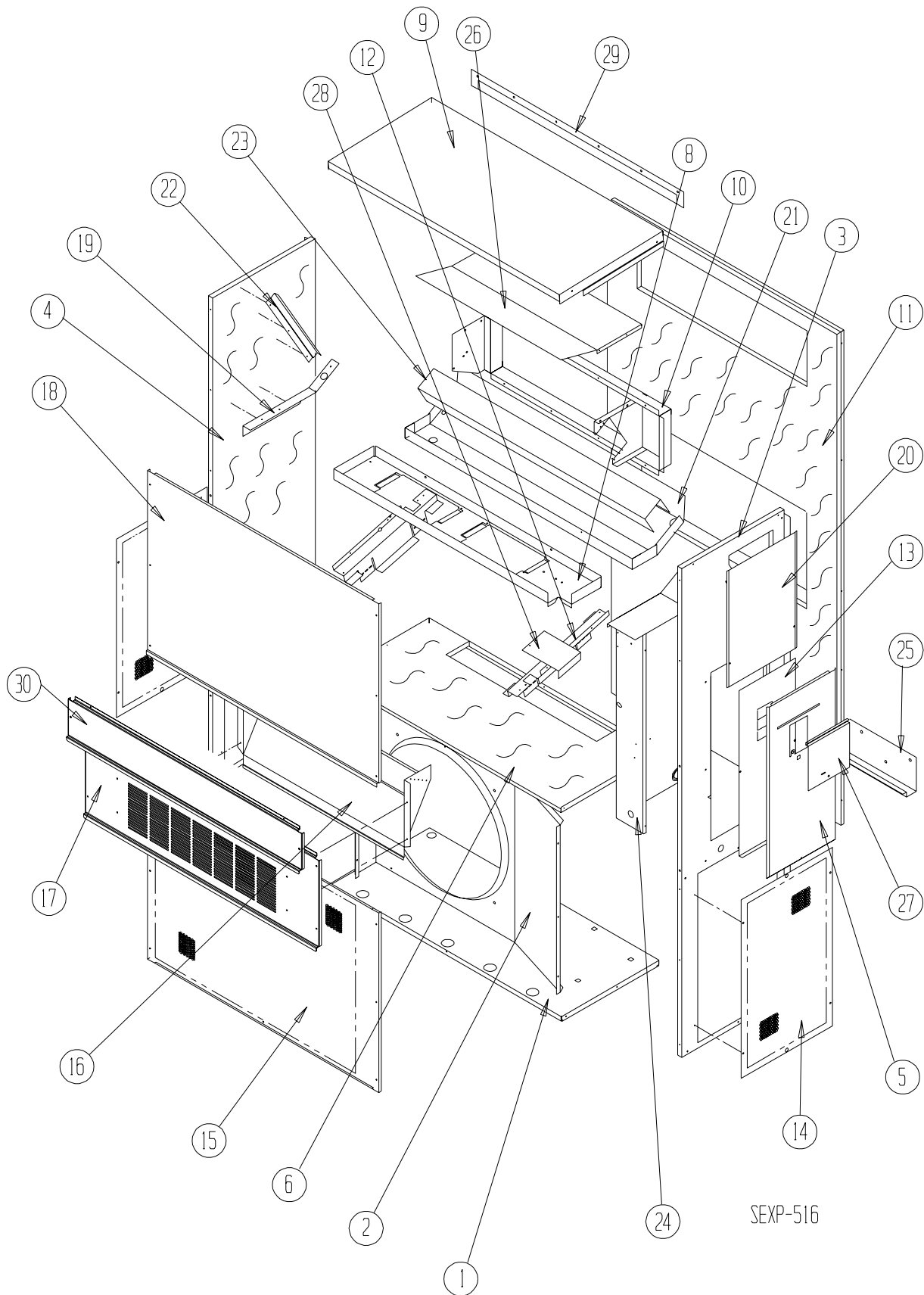

CABINET COMPONENTS

Dwg. No.	Part Number	Description	WE253-D	WE253-F
1	S127-204	Lower Base	X	X
1	S127-370 ③	Lower Base	X	X
2	125-023	Fan Shroud	X	X
2	125-056 ③	Fan Shroud	X	X
3	S500-228-* ①	Right Side	X	X
3	S500-441 ②	Right Side	X	X
3	S500-527 ②	Right Side	X	X
4	S500-229-* ①	Left Side	X	X
4	S500-442 ②	Left Side	X	X
4	S500X528 ③	Left Side	X	X
5	S533-109-* ①	Control Panel Cover (Outer)	X	X
5	S533-182 ②	Control Panel Cover (Outer)	X	X
5	S533-197 ③	Control Panel Cover (Outer)	X	X
6	S521X204	Condenser Partition	X	X
8	121X336	Blower Partition	X	X
9	S506-137-* ①	Top	X	X
9	S506-270 ②	Top	X	X
9	S506-276 ③	Top	X	X
10	S111X032	Outlet Air Frame Assembly	X	X
11	S508-097	Back	X	X
11	S508-208 ②	Back	X	X
11	S508-220 ③	Back	X	X
12	113X195	Filter Bracket	2	2
13	S132-104	Control Panel Cover (Inner)	X	
13	S132-172	Control Panel Cover (Inner)		X
14	118-056-* ①	Side Grille	2	2
14	118-060 ②	Side Grille	2	2
14	118-067 ③	Side Grille	2	2
15	118-050-* ①	Condenser Grille	X	X
15	118-070 ②	Condenser Grille	X	X
15	118-076 ③	Condenser Grille	X	X
16	BFAD-2	Fresh Air Damper Assembly	X	X
17	S552-451-* ①	Vent Option Door	X	X
17	S552-453-* ①	Vent Option Door with ERV	X	X
17	S552-454 ②	Vent Option Door	X	X
17	S552-460 ③	Vent Option Door	X	X
18	S514-163-* ①	Upper Front	X	X
18	S514-164 ②	Upper Front	X	X
18	S514-167 ③	Upper Front	X	X
19	105X850	Side Support	X	X
20	S143-034-* ①	Right Side Cover Plate (Outer)	X	X
20	S143-103 ②	Right Side Cover Plate (Outer)	X	X
20	S143-127 ③	Right Side Cover Plate (Outer)	X	X
21	S123-080	Drain Pan	X	X
22	147-044	Left Evaporator Support	X	X
23	137-195	Bottom Evaporator Fill	X	X
24	Control Panel Assembly	See Control Panel Assembly Drawing and Parts List Assembly	X	X
25	113-140	Bottom Mounting Bracket	X	X
26	135X127	Heat Shield	X	X
27	S153-218-* ①	Disconnect Access Door	X	X
27	S153-387 ②	Disconnect Access Door	X	X
27	S153-405 ③	Disconnect Access Door	X	X
28	137-259	Fill Plate	X	X
29	113-141-* ①	Top Rain Flashing	X	X
29	113-361 ③	Top Rain Flashing	X	X
30	S552-452-* ①	Filter Door	X	X
30	S552-455 ②	Filter Door	X	X
30	S552-461 ③	Filter Door	X	X
NS	S536-176	Cond. Part. Block Off Plate	X	X

① Exterior cabinet parts are manufactured with various paint color options. To insure that you receive the proper paint color, you must include the complete model and serial number of the unit for which cabinet parts are being ordered.

② Note: Exterior cabinet parts are manufactured from aluminum Code "A"

③ Note: Exterior cabinet parts are manufactured from stainless steel Code "S"

FUNCTIONAL COMPONENTS

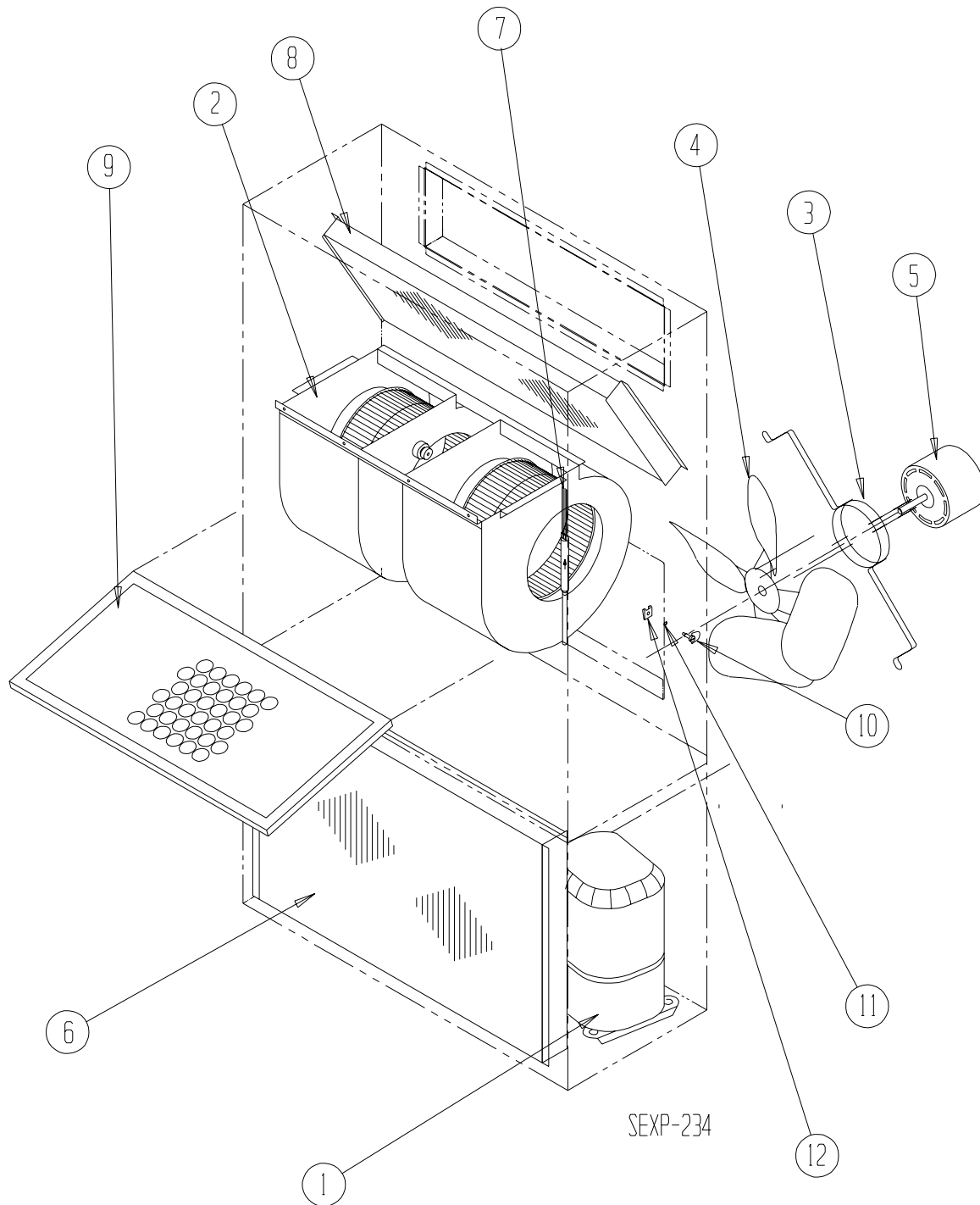

FUNCTIONAL COMPONENTS

Drawing No.	Part No.	Description	WE253-D	WE253-F
1	8000-369	Compressor	X	
1	8000-370	Compressor		X
2	S900-181	Blower Assembly	X	X
3	8200-001	Fan Motor Mount	X	X
4	5151-033	Fan Blade	X	X
5	8103-016	Condenser Motor	X	X
6	5051-071	Condenser Coil	X	X
7	800-0198	Cooling Capillary Assembly	X	X
8	5060-066	Evaporator Coil	X	X
9	7004-011	Air Filter 1" Throw Away	X	X
9	7003-032	Air Filter 1" Washable ①	X	X
9	7004-025	Air Filter 2" Pleated ①	X	X
10	1171-002	1/4 Turn Fastener	X	X
11	1171-024	1/4 Turn Retainer	X	X
12	1171-023	1/4 Receptacle	X	X
NS	1804-0106	High Pressure Switch (Flare)	X	X
NS	1804-0107	Low Pressure Switch (Flare) ①	X	X
NS	CMA-6	Low Ambient Control (Flare) ①	X	X
NS	5201-001	Liquid Line Filter Drier	X	X

NS = NOT SHOWN

① = Optional

CONTROL PANEL

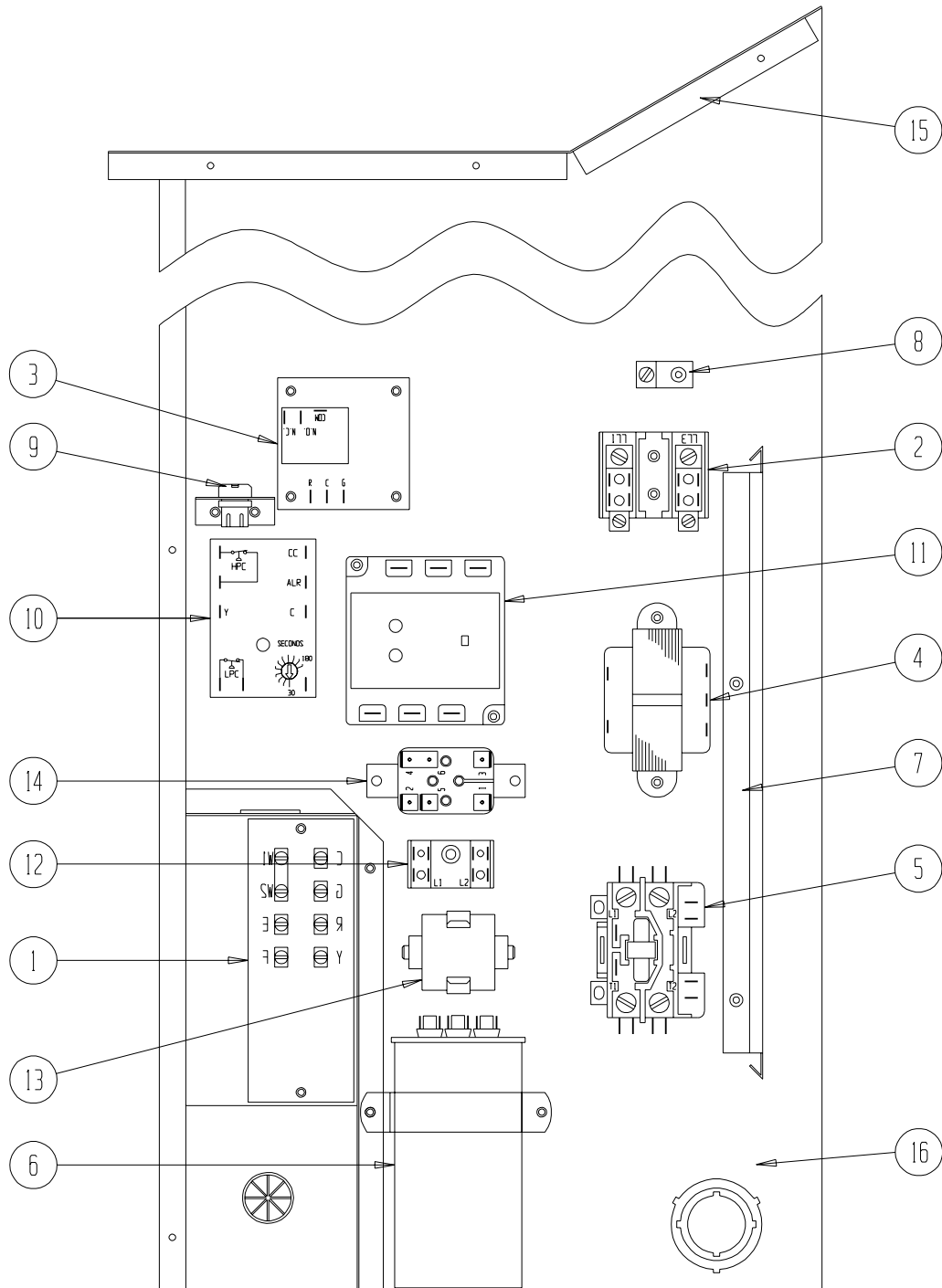

SEXP-291

CONTROL PANEL

Drawing No.	Part No.	Description	WE253-D	WE253-F
1	8607-020	Low Voltage Terminal Strip	X	X
2	8607-013	Terminal Block 2 Pole	X	2
3	8201-056	Blower Control	X	X
4	8407-034	Transformer	X	X
5	8401-007	Compressor Contactor	X	
5	8401-002	Compressor Contactor		X
6	8552-049	Compressor Capacitor	X	
6	8552-002	Outdoor Motor Capacitor		X
7	135-122	Wire Shield	X	X
8	8611-006	Ground Terminal	X	X
9	3000-968	6 Pin Connector	X	X
10	8201-088	Compressor Control Module	X	X
11	8201-085	Phase Monitor		X
12	8607-017	Terminal Block ① (shown)	X	X
13	8551-005	Start Device (PTCR) ① (shown)	X	
14	8201-062	Alarm Relay ① (shown)	X	X
15	117-137	Control Panel Top	X	X
16	117-123	Control Panel	X	X
NS	4095-128	Wiring Diagram	X	
NS	4095-620	Wiring Diagram		X

NS = Not Shown

① = Optional

BLOWER ASSEMBLY

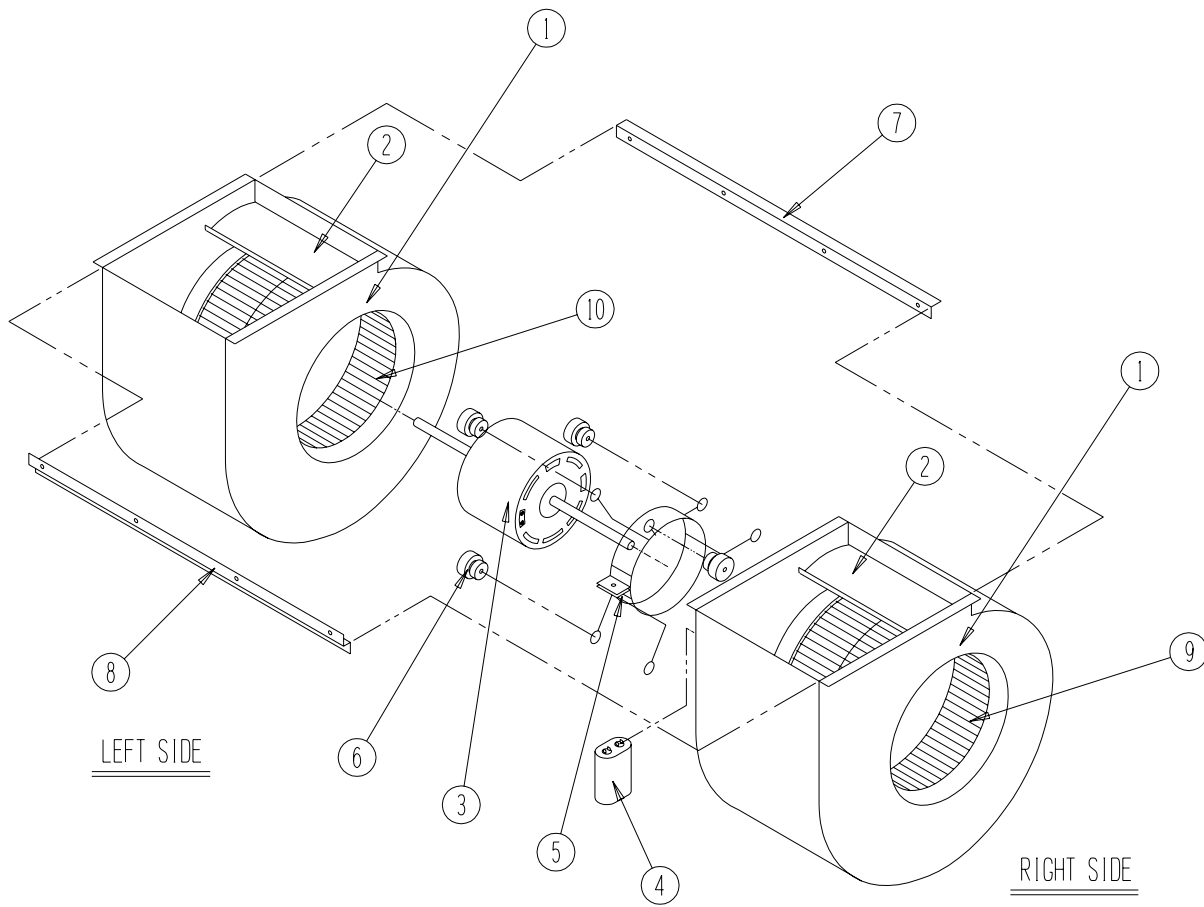

SEXP-346

Drawing No.	Part No.	Description	900-248
1	151-115	Housing	2
2	144-183	Cutoff	2
3	8102-011	Blower Motor (230/208)	X
4	8552-002	Capacitor	X
5	8200-031	Motor Mount	X
6	5451-011	Grommets	6
7	105-1061	Back Brace	X
8	103-435	Front Brace	X
9	5152-092	Wheel 9-6 CW	X
10	5152-093	Wheel 9-6 CCW	X