REPLACEMENT PARTS MANUAL

WALL MOUNTED PACKAGE AIR CONDITIONER

Models: **WE421**
WE482
WE602

General Notes

- Revised and/or additional pages may be issued from time to time.
- A complete and current manual consists of pages shown in the following contents section.

Important

- Contact the installing and/or local Bard distributor for all parts requirements. Make sure you have the complete model and serial number available from the unit rating plates.

Contents

Description	Page
Cabinet Components	
♦ Exploded View	1
♦ Usage List	2
Functional Components	
♦ Exploded View	3
♦ Usage List	4
Control Panel	
♦ Exploded View	5
♦ Usage List	6
Blower Assembly	
♦ Exploded View	7
♦ Usage List	7



CLIMATE CONTROL SOLUTIONS

BARD MANUFACTURING COMPANY
Bryan, Ohio 43506
Since 1914...Moving ahead, just as planned.

Manual: 2110-450B
Supersedes: 2110-450A
File: Tab 16
Date: 10-14-03

CABINET COMPONENTS

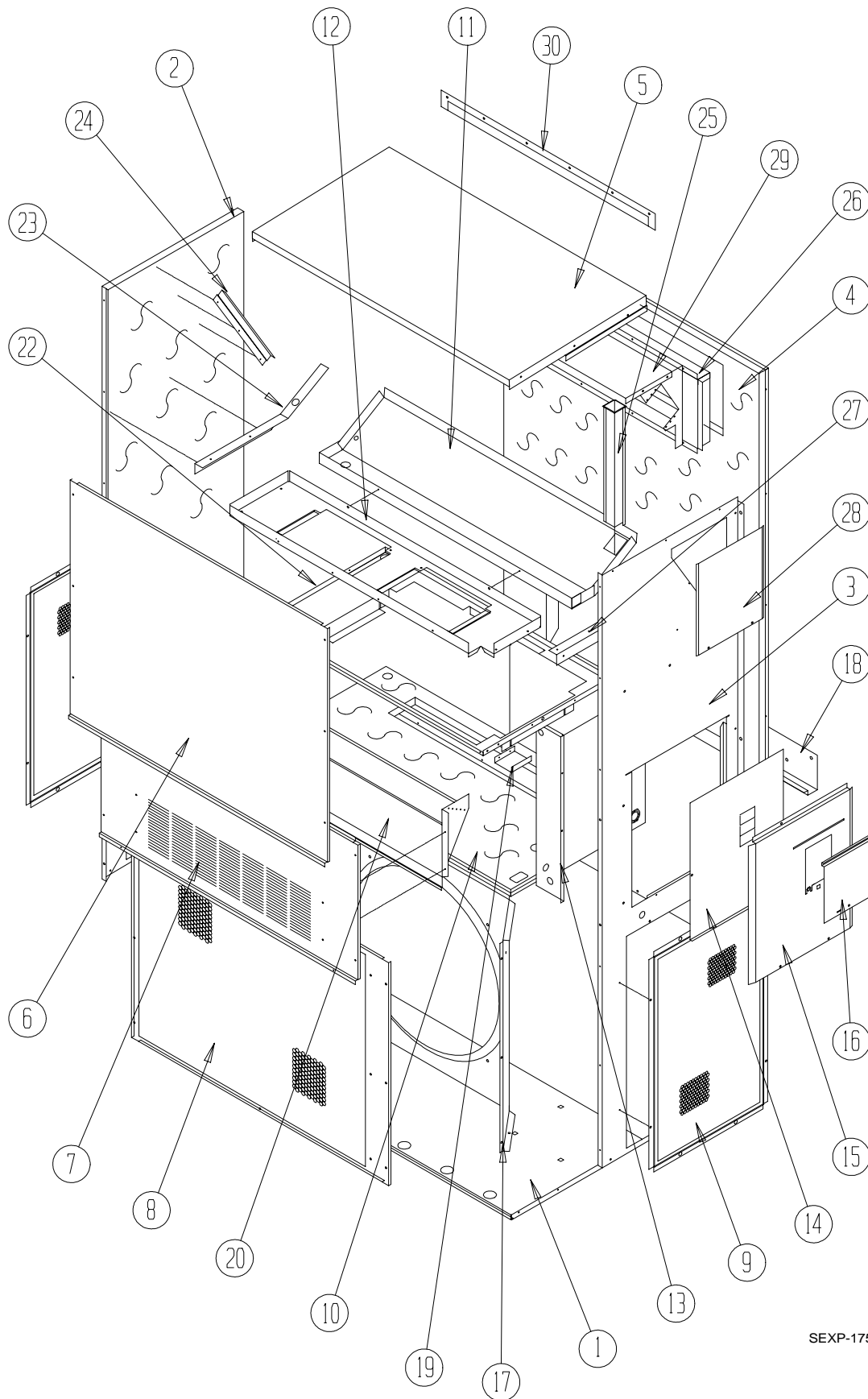

SEXP-175

CABINET COMPONENTS

Drawing No.	Part No.	Description	WE421-F	WE482-F	WE602-F
1	S127X214	Lower Base	X	X	X
2	S500-262-* ①	Left Side	X	X	X
3	S500-261-* ①	Right Side	X	X	X
4	S508-098	Back	X	X	X
5	S506-142-* ①	Top	X	X	X
6	S514-077-* ①	Upper Front	X	X	X
7	S552-224-* ①	Service Door	X	X	X
8	118-031-* ①	Condenser Grille	X	X	X
9	118-032-* ①	Side Grille	2	2	2
10	S521X258	Condenser Partition	X	X	X
11	123-083	Drain Pan	X	X	X
12	121X216	Blower Partition	X	X	X
13	Control Panel Assembly	See Control Panel Assembly Drawing & Parts List	X	X	X
14	S133-115	Control Panel Cover (Inner)	X	X	X
15	S533-113-* ①	Control Panel Cover (Outer)	X	X	X
16	S153-218-* ①	Disconnect Access Door	X	X	X
17	125-024	Fan Shroud	X	X	X
18	113-140	Bottom Mounting Bracket	X	X	X
19	137-209	Fill	X	X	X
20	BFAD-5	Fresh Air Damper Assembly	X	X	X
22	131X099	Filter Tray	X	X	X
23	105X877	Left Side Support	X	X	X
24	147-046-* ①	Left Evaporator Support	X	X	X
25	135-128	Raceway	2	2	2
26	111X034	Outlet Air Frame Assembly	X	X	X
27	105X878	Right Side Support	X	X	X
28	S143-042-* ①	Right Side Cover Plate (Outer)	X	X	X
29	135-129	Heat Shield	X	X	X
30	113-150-* ①	Top Rain Flashing	X	X	X

① NOTE: Exterior cabinet parts are manufactured with various paint color options. To insure that you receive the proper paint color, you must include the complete model and serial number of the unit for which cabinet parts are being ordered.

FUNCTIONAL COMPONENTS

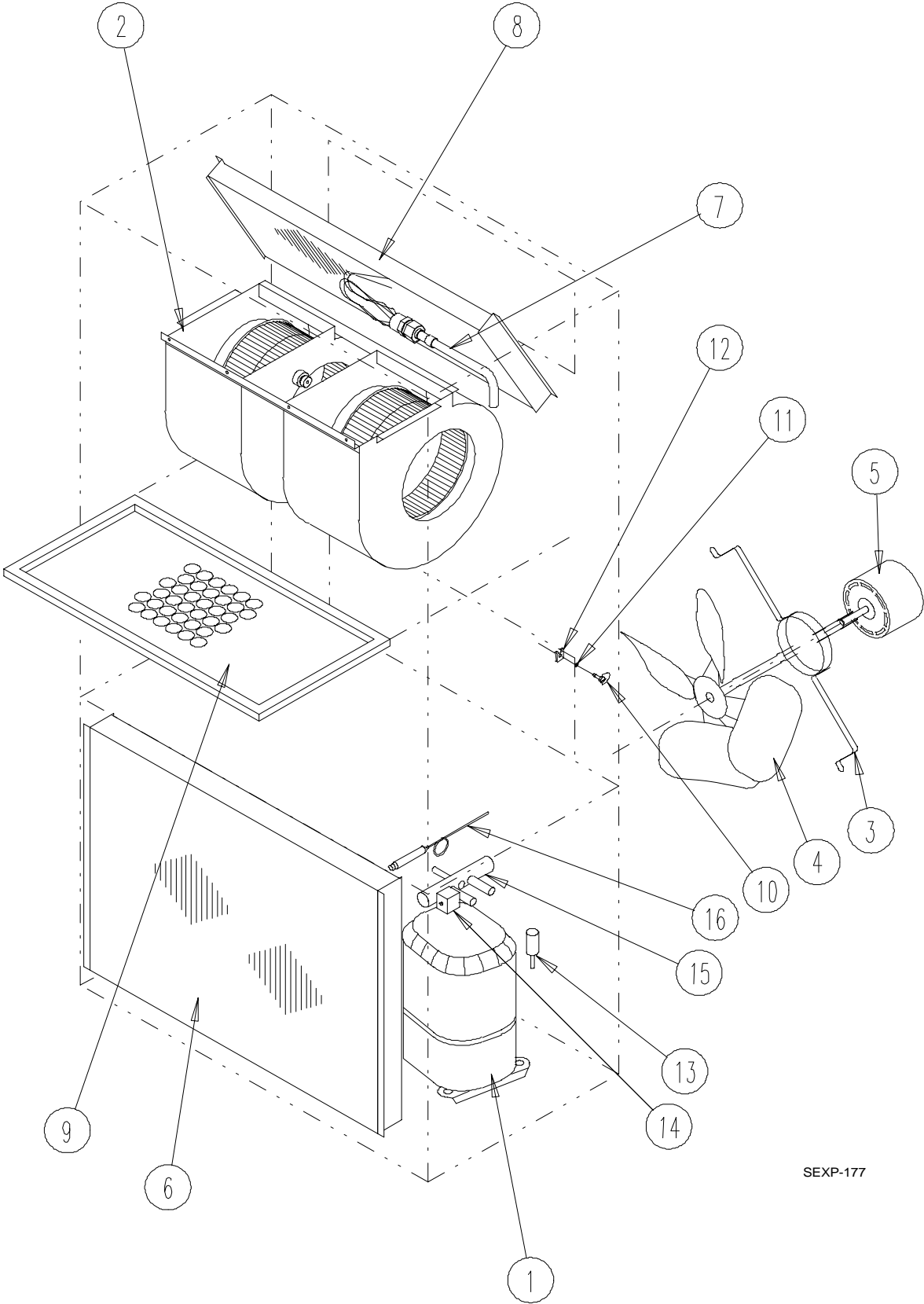

SEXP-177

FUNCTIONAL COMPONENTS

Drawing No.	Part No.	Description	WE421-F	WE482-F	WE602-F
1	8000-244	Compressor	X		
1	8000-245	Compressor		X	
1	8000-246	Compressor			X
2	S900-184	Blower Assembly	X		
2	S900-183	Blower Assembly		X	
2	S900-185	Blower Assembly			X
3	8200-004	Fan Motor Mount	X	X	X
4	5151-027	Fan Blade	X	X	X
5	8105-039	Condenser Motor	X	X	X
6	5051-078	Condenser Coil	X		
6	5051-074	Condenser Coil		X	X
7	800-0203	Cooling Capillary Assembly	X		
7	800-0232	Cooling Capillary Assembly		X	X
8	5060-070	Evaporator Coil	X		
8	5060-082	Evaporator Coil		X	X
9	7004-016	Air Filter 1" Throw-Away	X	X	X
9	7003-030	Air Filter 1" Washable	X	X	X
9	7004-027	Air Filter 2" Pleated	X	X	X
10	1171-022	1/4 Turn Fastener	X	X	X
11	1171-024	1/4 Turn Retainer	X	X	X
12	1171-023	1/4 Turn Receptacle	X	X	X
13	1804-0106	High Pressure Switch (Flare)	X	X	X
NS	1804-0107	Low Pressure Switch (Flare) ①	X	X	X
NS	CMA-6	Low Ambient Control (Flare) ①	X	X	X
NS	5201-001	Liquid Line Filter Drier	X	X	X

NS – Not Shown

① – Optional

CONTROL PANEL

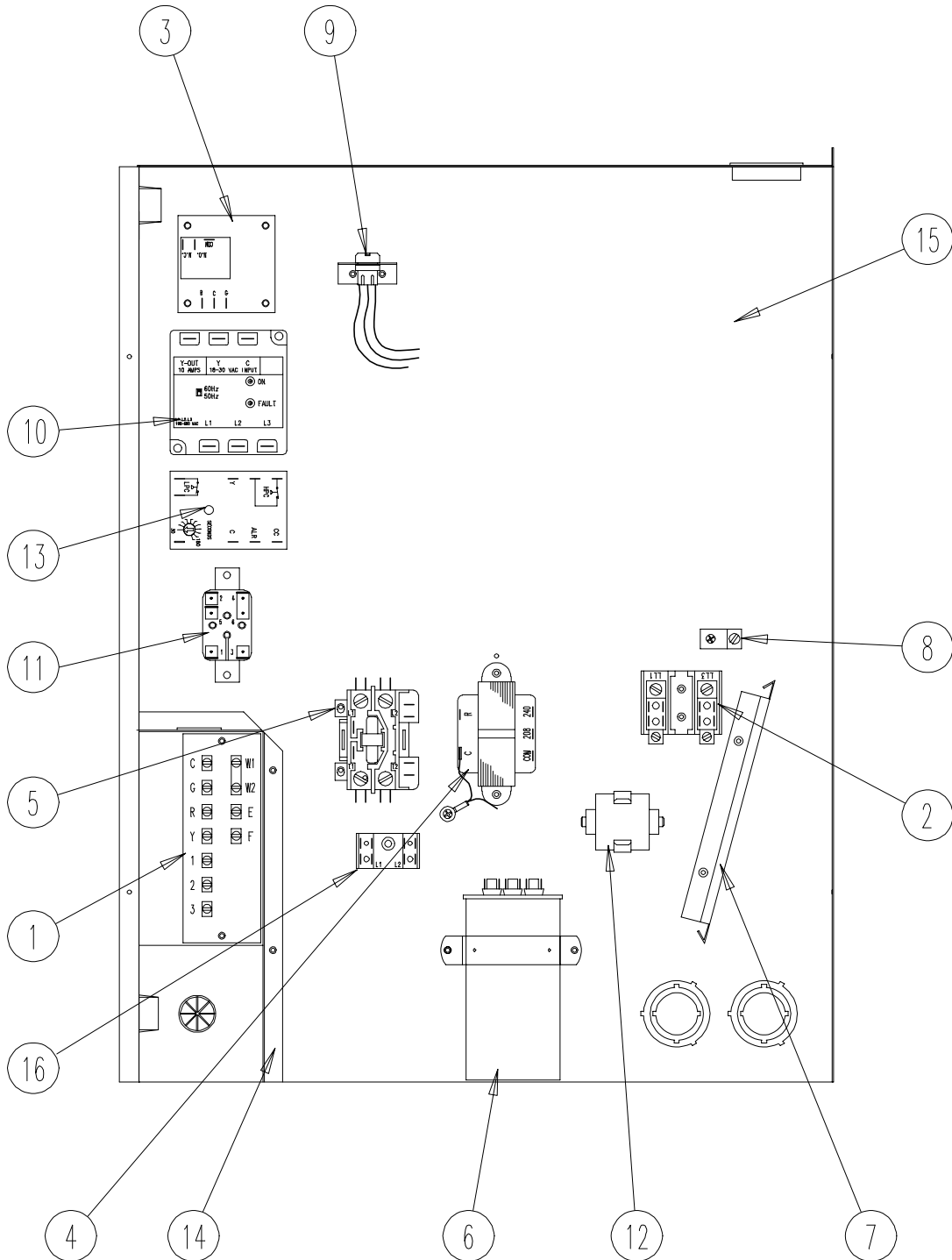

SEXP-325

CONTROL PANEL

Drawing No.	Part No.	Description	WE421-F	WE482-F	WE602-F
1	8607-020	Low Voltage Terminal Strip	X		
2	8607-013	Terminal Block 2 Pole	2	2	2
3	8201-056	Blower Control	X	X	X
4	8407-034	Transformer	X	X	X
5	8401-002	Compressor Contactor	X	X	X
6	8552-005	Outdoor Motor Capacitor	X	X	X
7	135-130	Wire Shield	X	X	X
8	8611-006	Ground Terminal	X	X	X
9	3000-978	6 Pin Connector	X	X	X
10	8201-085	Phase Monitor	X	X	X
11	8201-062	Alarm Relay (Optional)	X	X	X
13	8201-088	Compressor Control Module	X	X	X
14	117X139	Low Voltage Box	X	X	X
15	117X143	Control Panel	X	X	X
16	8607-017	Terminal Block (Optional)	X	X	X
NS	8615-053	Pull Disconnect	X	X	X
NS	4095-623	Wiring Diagram		X	X
NS	4095-622	Wiring Diagram	X		

NS - Not shown

BLOWER ASSEMBLY

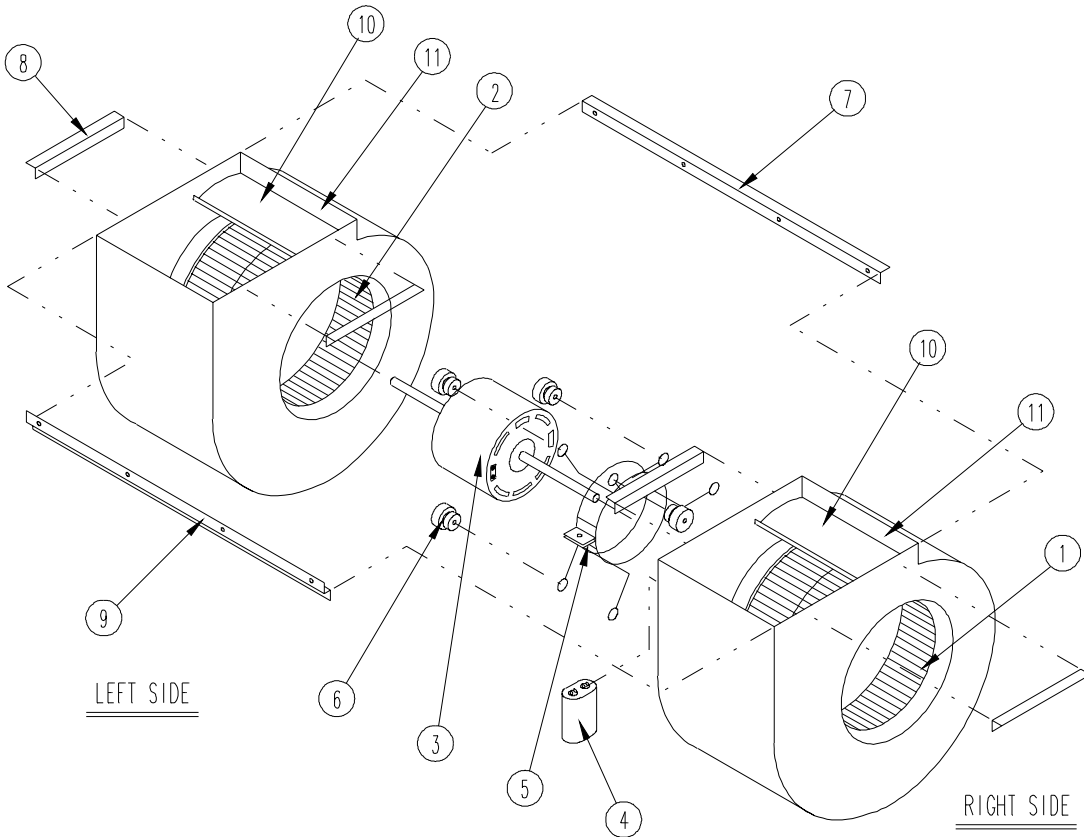

SEXP-178

Drawing No.	Part No.	Description	900-183	900-185
1	5152-011	10 Inch Wheel (CW)		X
1	5152-057	9 Inch Wheel (CW)	X	
2	5152-012	10 Inch Wheel (CCW)		X
2	5152-058	9 Inch Wheel (CCW)	X	
3	8106-030	Blower Motor (230/208)	X	X
4	8552-005	Capacitor	X	X
5	8200-040	Motor Mount	X	X
6	5451-011	Grommets	6	6
7	105-880	Back Brace	X	X
8	105-881	Side Angle	4	4
9	103-389	Front Brace	X	X
10	151-101	Housing	2	2
11	144-166	Diffuser	2	2