REPLACEMENT PARTS MANUAL

WALL MOUNTED PACKAGE AIR CONDITIONER

Models: **WA381** **WA424D**
 WA423 **WA485D**
 WA484 **WA604D**
 WA491 **WA602**

General Notes

- Revised and/or additional pages may be issued from time to time.
- A complete and current manual consists of pages shown in the following contents section.

Important

- Contact the installing and/or local Bard distributor for all parts requirements. Make sure you have the complete model and serial number available from the unit rating plates.

Contents

Description	Page
Cabinet Components	
♦ Exploded View	1
♦ Usage List	2
♦ Usage List	3
Functional Components	
♦ Exploded View	4
♦ Usage List	5
♦ Usage List	6
Control Panel	
♦ Exploded View	7
♦ Usage List	8
♦ Usage List	9
♦ Blank Page	10
♦ Exploded View	11
♦ Usage List	12
Blower Assembly	
♦ Exploded View	13
♦ Usage List	13



BARD MANUFACTURING COMPANY
Bryan, Ohio 43506

Since 1914...Moving ahead, just as planned.

Manual: 2110-452B
Supersedes: 2110-452A
File: Tab 16
Date: 07-23-04

CABINET COMPONENTS

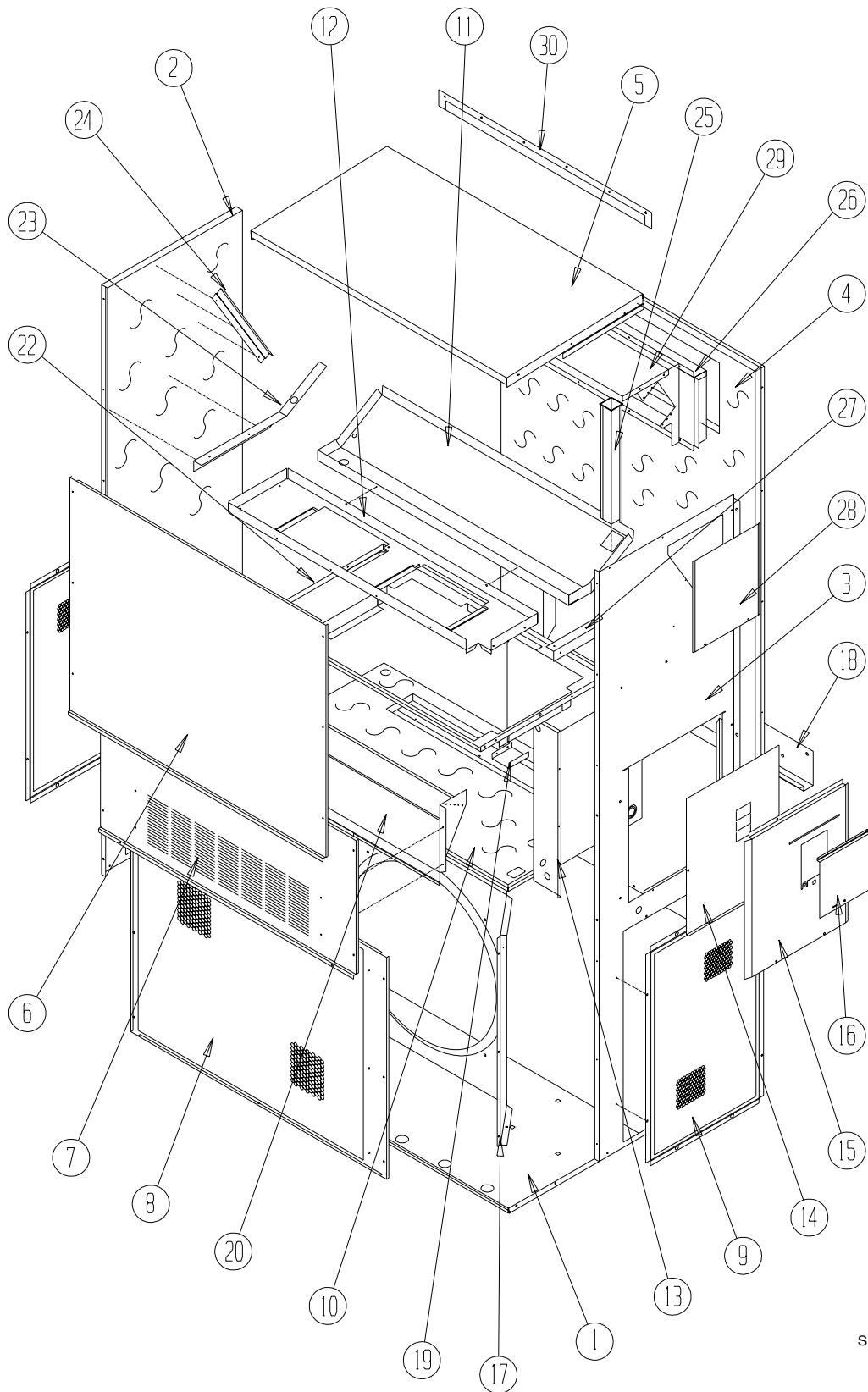

SEXP-175

This drawing is referenced in Tables on Pages 2 and 3

CABINET COMPONENTS

Drawing No.	Part No.	Description	WA381-A, B	WA381-C	WA423-A,B,E	WA423-C,F	WA424DA, B	WA424DC	WA484-A,B,E	WA484-C, F	WA485DA,B	WA485DC
1	S127X214	Lower Base	X	X	X	X	X	X	X	X	X	X
2	S500-262-* ①	Left Side	X	X	X	X	X	X	X	X	X	X
3	S500-261-* ①	Right Side	X	X	X	X	X	X	X	X	X	X
4	S508-098	Back	X	X	X	X	X	X	X	X	X	X
5	S506-142-* ①	Top	X	X	X	X	X	X	X	X	X	X
6	S514-077-* ①	Upper Front	X	X	X	X	X	X	X	X	X	X
7	S552-224-* ①	Service Door	X	X	X	X	X	X	X	X	X	X
8	118-048-* ①	Condenser Grille	X	X	X	X	X	X	X	X	X	X
9	118-057-* ①	Side Grille	2	2	2	2	2	2	2	2	2	2
10	S521X258	Condenser Partition	X	X	X	X	X	X	X	X	X	X
11	123-083	Drain Pan			X	X	X	X	X	X	X	X
11	12 -102	Drain Pan	X	X								
12	121X216	Blower Partition			X	X	X	X	X	X	X	X
13	Control Panel	See Control Panel Assembly Assembly Drawing & Parts List	X	X	X	X	X	X	X	X	X	X
14	S133-114	Control Panel Cover (Inner)	X		X		X		X		X	
14	S13 -171	Control Panel Cover (Inner)		X		X		X		X		X
15	S533-113-* ①	Control Panel Cover (Outer)	X	X	X	X	X	X	X	X	X	
16	S153-218-* ①	Dicsonnect Access Door	X	X	X	X	X	X	X	X	X	X
17	125-024	Fan Shroud	X	X	X	X	X	X	X	X	X	X
18	113-140	Bottom Mounting Bracket	X	X	X	X	X	X	X	X	X	X
19	137-209	Fill	X	X	X	X	X	X	X	X	X	X
20	BFAD-5	Fresh Air Damper Assembly	X	X	X	X	X	X	X	X	X	X
22	131X099	Filter Tray	X	X	X	X	X	X	X	X	X	X
23	105X877	Left Side Support	X	X	X	X	X	X	X	X	X	X
24	147-046-* ①	Left Evaporator Support	X	X	X	X	X	X	X	X	X	X
25	135-128	Raceway	2	2	2	2	2	2	2	2	2	2
26	111X034	Oulet Airframe Assembly	X	X	X	X	X	X	X	X	X	X
27	105X878	Right Side Support	X	X	X	X	X	X	X	X	X	X
28	S143-042-* ①	Right Side Cover Plate (Outer)	X	X	X	X	X	X	X	X	X	X
29	135-129	Heat Shield	X	X	X	X	X	X	X	X	X	X
30	113-150-* ①	Top Rain Flashing	X	X	X	X	X	X	X	X	X	X

① NOTE: Exterior cabinet parts are manufactured with various paint color options. To insure that you receive the proper paint color, you must include the complete model and serial number of the unit for which cabinet parts are being ordered.

This Table is references drawing on Page 1

CABINET COMPONENTS

Drawing No.	Part No.	Description	WA491-A, B	WA491-C	WA602-A,B,E	WA602-C,F	WA604DA, B	WA604DC
1	S127X214	Lower Base	X	X	X	X	X	X
2	S500-262-* ①	Left Side	X	X	X	X	X	X
3	S500-261-* ①	Right Side	X	X	X	X	X	X
4	S508-098	Back	X	X	X	X	X	X
5	S506-142-* ①	Top	X	X	X	X	X	X
6	S514-077-* ①	Upper Front	X	X	X	X	X	X
7	S552-224-* ①	Service Door	X	X	X	X	X	X
8	118-031-* ①	Condenser Grille	X	X	X	X	X	X
9	118-032-* ①	Side Grille	2	2	2	2	2	2
10	S521X258	Condenser Partition	X	X	X	X	X	X
11	123-083	Drain Pan			X	X	X	X
11	123-102	Drain Pan	X	X				
12	121X216	Blower Partition	X	X	X	X	X	X
13	Control Panel Assembly	See Control Panel Assembly Drawing & Parts List	X	X	X	X	X	X
14	S133-114	Control Panel Cover (Inner)	X		X		X	
14	S133-114	Control Panel Cover (Inner)		X		X		X
15	S533-114 ①	Control Panel Cover (Outer)	X	X	X	X	X	X
16	S153-218-* ①	Dicconnect Access Door	X	X	X	X	X	X
17	125-024	Fan Shroud	X	X	X	X	X	X
18	113-140	Bottom Mounting Bracket	X	X	X	X	X	
19	137-209	Fill	X	X	X	X	X	X
20	BFAD-5	Fresh Air Damper Assembly	X	X	X	X	X	X
22	131X099	Filter Tray	X	X	X	X	X	X
23	105X877	Left Side Support	X	X	X	X	X	X
24	147-046-* ①	Left Evaporator Support	X	X	X	X	X	X
25	135-128	Raceway	2	2	2	2	2	2
26	111X034	Outlet Airframe Assembly	X	X	X	X	X	X
27	105X878	Right Side Support	X	X	X	X	X	X
28	S143-042-* ①	Right Side Cover Plate (Outer)	X	X	X	X	X	X
29	135-129	Heat Shield	X	X	X	X	X	X
30	113-150-* ①	Top Rain Flashing	X	X	X	X	X	X

① NOTE: Exterior cabinet parts are manufactured with various paint color options. To insure that you receive the proper paint color, you must include the complete model and serial number of the unit for which cabinet parts are being ordered.

This Table is references drawing on Page 1

FUNCTIONAL COMPONENTS

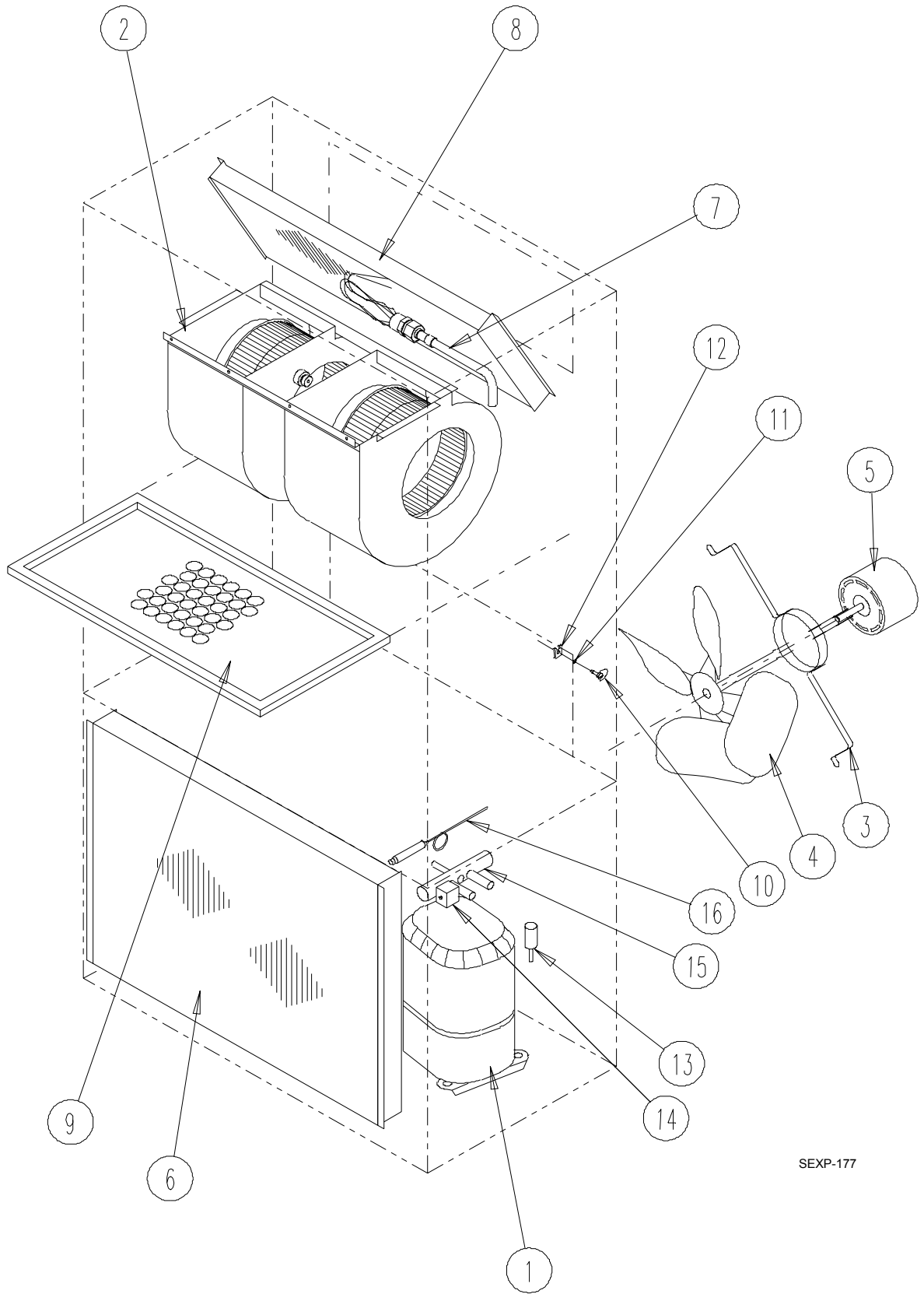

SEXP-177

This Exploded View references Tables on Page 5 and 6

FUNCTIONAL COMPONENTS

Drawing			WA381-A	WA381-B	WA381-C	WA423-A	WA423-B, E	WA423-C	WA423-F	WA424DA	WA424DB	WA424DC	WA491-A	WA491-B	WA491-C
No.	Part No.	Description													
1	8000-253	Compressor				X				X					
1	8000-205	Compressor					X				X				
1	8000-206	Compressor						X	X			X			
1	8000-251	Compressor	X												
1	8000-163	Compressor		X											
1	8000-164	Compressor			X										
1	8000-218	Compressor											X		
1	8000-219	Compressor												X	
1	8000-220	Compressor													X
2	S900-183	Blower Assembly				X	X			X	X				
2	S900-184	Blower Assembly						X				X			
2	S900-242	Blower Assembly	X	X									X	X	
2	S900-243	Blower Assembly			X										X
3	8200-004	Fan Motor Mount	X	X	X	X	X	X	X	X	X	X	X	X	X
4	5151-027	Fan Blade	X	X	X	X	X	X	X	X	X	X	X	X	X
5	8105-030	Condenser Motor			X			X				X			X
5	8105-039	Condenser Motor	X	X		X	X		X	X	X		X	X	
6	5051-078	Condenser Coil	X	X	X	X	X	X	X	X	X	X			
6	5051-074	Condenser Coil											X	X	X
7	5651-078	Expansion Valve								X	X	X			
7	800-0319	Cooling Capillary Assembly				X	X	X	X						
7	800-0313	Distributor Assembly	X	X	X										
7	800-0314	Distributor Assembly											X	X	X
8	5060-070	Evaporator Coil	X	X	X										
8	917-004	Evaporator Coil								X	X	X			
8	5060-084	Evaporator Coil											X	X	X
8	5060-113	Evaporator Coil				X	X	X	X						
9	7004-016	Air Filter 1" Throw-Away	X	X	X	X	X	X	X	X	X	X	X	X	X
9	7003-030	Air Filter 1" Washable	X	X	X	X	X	X	X	X	X	X	X	X	X
9	7004-027	Air Filter 2" Pleated	X	X	X	X	X	X	X	X	X	X	X	X	X
10	1171-022	1/4 Turn Fastener	X	X	X	X	X	X	X	X	X	X	X	X	X
11	1171-024	1/4 Turn Retainer	X	X	X	X	X	X	X	X	X	X	X	X	X
12	1171-023	1/4 Receptacle	X	X	X	X	X	X	X	X	X	X	X	X	X
13	1804-0106	High Pressure Switch (Flare)	X	X	X	①	①	①	①				X	X	X
14	5650-043	Solenoid Coil								X	X	X			
15	5650-036	Three-Way Valve								X	X	X			
16	800-0271	Drain Back Capillary								X	X	X			
NS	1804-0107	Low Pressure Switch (Flare) ①	X	X	X	X	X	X	X				X	X	X
NS	CMA-6	Low Ambient Control (Flare) ①	X	X	X	X	X	X	X				X	X	X

NS – Not Shown

①– Optional on these models

This Table references Exploded View on Page 4

FUNCTIONAL COMPONENTS

Dwg. No.	Part No.	Description	WA484-A	WA484-B,E	WA484-C	WA484-F	WA485DA	WA485DB	WA485DC	WA602-A	WA602-B,E	WA602-C	WA602-F	WA604DA	WA604DB	WA604DC
1	8000-153	Compressor							X					X		
1	8000-154	Compressor								X					X	
1	8000-155	Compressor									X	X				X
1	8000-236	Compressor	X				X									
1	8000-221	Compressor		X				X								
1	8000-222	Compressor			X	X			X							
2	S900-183	Blower Assembly	X	X		X	X	X								
2	S900-184	Blower Assembly			X				X							
2	S900-185	Blower Assembly								X	X		X	X	X	
2	S900-186	Blower Assembly										X				X
3	8200-004	Fan Motor Mount	X	X	X	X	X	X	X	X	X	X	X	X	X	X
4	5151-027	Fan Blade	X	X	X	X	X	X	X	X	X	X	X	X	X	X
5	8105-030	Condenser Motor			X			X					X			X
5	8105-039	Condenser Motor	X	X		X	X	X	X	X	X		X	X	X	X
6	5051-074	Condenser Coil	X	X	X	X	X	X	X	X	X	X	X	X	X	X
7	5651-078	Expansion Valve					X	X	X							
7	5651-079	Expansion Valve												X	X	X
7	800-0204	Cooling Capillary Assembly	X	X	X	X										
7	800-0209	Cool. Cap. Assy.(S/N before M95)								X	X	X	X			
7	800-0234	Distributor Assy.(S/N starting M95)								X	X	X	X			
8	5060-070	Evaporator Coil	X	X	X	X										
8	5060-071	Evap. Coil (S/N before M95)								X	X	X	X			
8	5060-082	Evap. Coil (S/N starting M95)								X	X	X	X			
8	917-0042	Evaporator Coil					X	X	X							
8	917-0044	Evaporator Coil												X	X	X
9	7004-016	Air Filter 1" Throw-Away	X	X	X	X	X	X	X	X	X	X	X	X	X	X
9	7003-030	Air Filter 1" Washable	X	X	X	X	X	X	X	X	X	X	X	X	X	X
9	7004-027	Air Filter 2" Pleated	X	X	X	X	X	X	X	X	X	X	X	X	X	X
10	1171-022	1/4 Turn Fastener	X	X	X	X	X	X	X	X	X	X	X	X	X	X
11	1171-024	1/4 Turn Retainer	X	X	X	X	X	X	X	X	X	X	X	X	X	X
13	1804-0106	High Pressure Switch (Flare) ①	X	X	X	X	X	X	X	X	X	X	X	X	X	X
14	5650-043	Solenoid Coil					X	X	X					X	X	X
15	5650-036	Three-Way Valve					X	X	X					X	X	X
16	800-0272	Drain Back Capillary					X	X	X					X	X	X
NS	CMA-6	Low Ambient Control (Flare)	①	X	X	X	X				X	X	X	X		
NS	1804-0107	Low Pressure Switch (Flare) ①	X	X	X	X				X	X	X	X			

NS – Not Shown

① – Optional on these models

This Table references Exploded View on Page 4

CONTROL PANEL

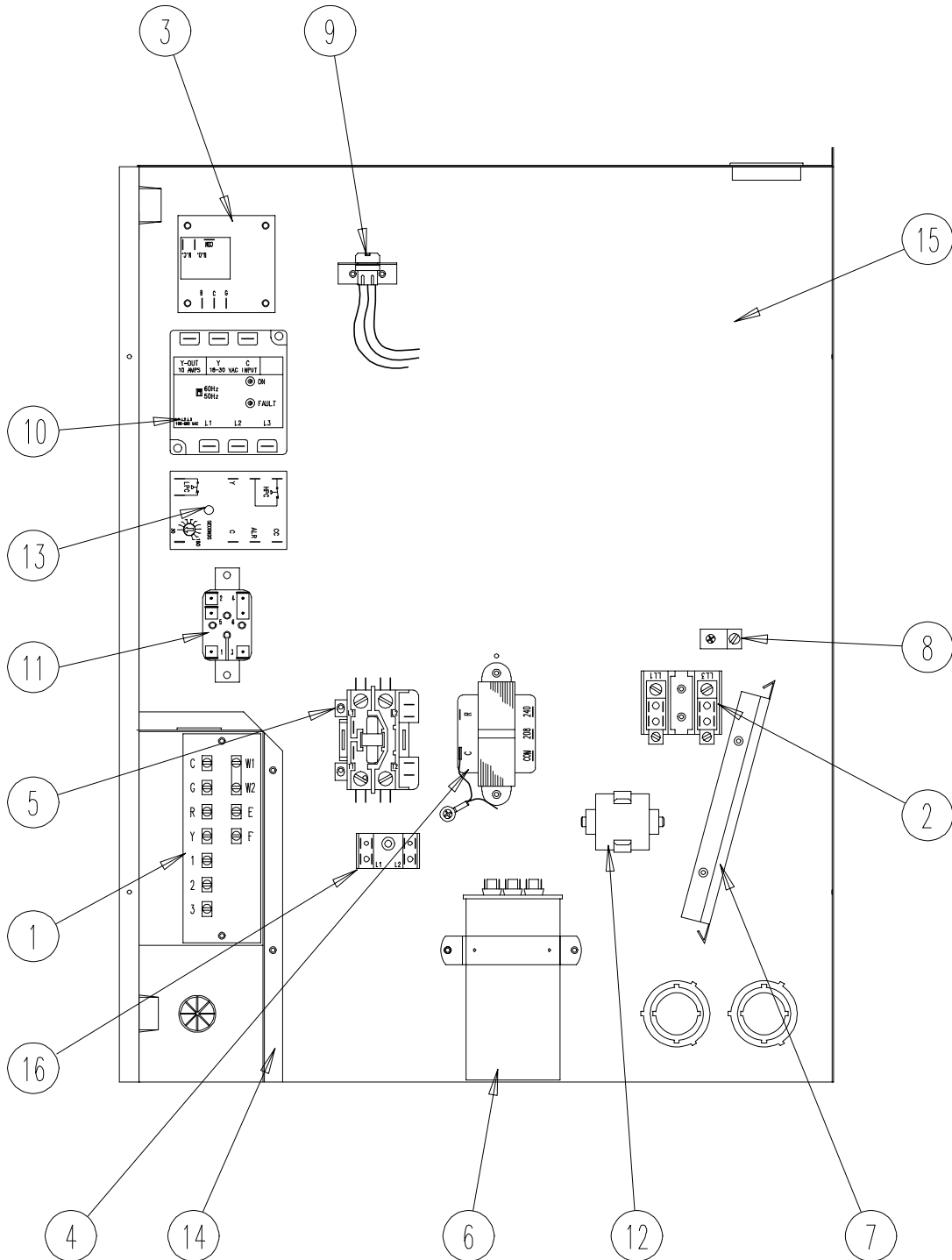

This drawing is referenced in Tables on Pages 8 and 9

SEXP-325

CONTROL PANEL

Drawing No.	Part No.	Description	WA381-A	WA381-B	WA381-C	WA423-A	WA423-B	WA423-C	WA423-E	WA423-F	WA484-A	WA484-B	WA484-C	WA484-E	WA484-F
1	8607-020	Low Voltage Terminal Strip	X	X	X	X	X	X	X	X	X	X	X	X	
2	8607-013	Terminal Block 2 Pole	X			X	X	X		2	X				2
2	8607-014	Terminal Block 3 Pole		X	X	X	X	X			X	X	X		
2	8607-015	Phenolic Insulator			X			X				X			
3	8201-056	Blower Control	X	X		X	X		X	X	X	X		X	X
3	8201-032	Blower Relay			X			X					X		
4	8407-034	Transformer	X	X		X	X		X	X	X	X		X	X
4	8407-042	Transformer			X			X					X		
5	8401-002	Compressor Contactor		X	X		X	X	X	X		X	X	X	X
5	8401-025	Compressor Contactor	X			X					X				
6	8552-005	Outdoor Motor Capacitor		X			X		X	X		X		X	X
6	8552-026	Outdoor Motor Capacitor			X			X					X		
6	8552-055	Compressor Capacitor	X			X					X				
6	8552-072	Compressor Capacitor													
7	135-130	Wire Shield	X	X	X	X	X	X	X	X	X	X	X	X	X
8	8611-006	Ground Terminal	X	X	X	X	X	X	X	X	X	X	X	X	X
9	3000-97	6 Pin Connector	X	X	X	X	X	X	X	X	X	X	X	X	X
10	8201-08	Phase Monitor		X	X		X	X	X	X		X	X	X	X
11	8201-062	Alarm Relay (Optional)	X	X	X	X	X	X	X	X	X	X	X	X	X
12	8551-005	Start Device (PTCR) (Optional)	X			X					X				
13	8201-088	Compressor Control Module	X	X	X	①	①	①	①	①	X	X	X	X	X
14	117X139	Low Voltage Box	X	X	X	X	X	X	X	X	X	X	X	X	X
15	117X143	Control Panel	X	X	X	X	X	X	X	X	X	X	X	X	X
16	8607-017	Terminal Block (Optional)	X	X	X	X	X	X	X	X	X	X	X	X	X
NS	8615-038	Circuit Breaker 35 A 2 Pole ②	X			X					X				
NS	8615-040	Circuit Breaker 50 A 2 Pole ②					X		X			X		X	
NS	8615-042	Circuit Breaker 35 A 3 Pole ②										X			
NS	8615-052	Circuit Breaker 30 A 3 Pole ②		X									X		
NS	8615-053	Pull Disconnect ②			X			X		X			X		X
NS	4095-137	Wiring Diagram				X									
NS	4095-128	Wiring Diagram	X								X				
NS	4095-234	Wiring Diagram					X								
NS	4095-227	Wiring Diagram		X								X			
NS	4095-229	Wiring Diagram												X	
NS	4095-238	Wiring Diagram							X						
NS	4095-321	Wiring Diagram					X								
NS	4095-318	Wiring Diagram			X								X		
NS	4095-623	Wiring Diagram													X
NS	4095-631	Wiring Diagram								X					

① Optional on these models.

② Circuit breakers listed are for units without electric heat."0Z" models. Hot gas bypass models not available without electric heat. See Heater Replacement Parts Manual for units with electric heat.

NS = Not shown

This Table is references drawing on Page 7

CONTROL PANEL

Drawing No.	Part No.	Description	WA491-A	WA491-B	WA491-C	WA602-A	WA602-B	WA602-C	WA602-E	WA602-F
2	8607-013	Terminal Block 2 Pole	X			X				2
2	8607-014	Terminal Block 3 Pole		X	X		X	X	X	
2	8607-015	Phenolic Insulator			X			X		
3	8201-056	Blower Control	X	X		X	X		X	X
3	8201-032	Blower Relay			X			X		
4	8407-034	Transformer	X	X		X	X		X	X
4	8407-042	Transformer			X			X		
5	8401-002	Compressor Contactor		X	X		X	X	X	X
5	8401-025	Compressor Contactor	X			X				
6	8552-005	Outdoor Motor Capacitor		X			X		X	X
6	8552-026	Outdoor Motor Capacitor			X			X		
6	8552-059	Compressor Capacitor	X							
6	8552-058	Compressor Capacitor				X				
7	135-130	Wire Shield	X	X	X	X	X	X	X	X
8	8611-006	Ground Terminal	X	X	X	X	X	X	X	X
9	3000-978	6 Pin Connector	X	X	X	X	X	X	X	X
10	8201-085	Phase Monitor		X	X		X	X	X	X
11	8201-062	Alarm Relay (Optional)	X	X	X	X	X	X	X	X
12	8551-005	Start Device (PTCR) (Optional)	X			X				
13	8201-088	Compressor Control Module	X	X	X	X	X	X	X	X
14	117X139	Low Voltage Box	X	X	X	X	X	X	X	X
15	117X143	Control Panel	X	X	X	X	X	X	X	X
16	8607-017	Terminal Block (Optional)	X	X	X	X	X	X	X	X
NS	8615-040	Circuit Breaker 50 A 2 Pole ②	X							
NS	8615-043	Circuit Breaker 40 A 3 Pole ②		X						
NS	8615-053	Pull Disconnect ②			X			X		X
NS	8615-041	Circuit Breaker 60 A 2 Pole ②				X				
NS	8615-044	Circuit Breaker 45 A 3 Pole ②					X		X	
NS	4095-128	Wiring Diagram	X			X				
NS	4095-227	Wiring Diagram		X			X			
NS	4095-229	Wiring Diagram							X	
NS	4095-318	Wiring Diagram			X			X		
NS	4095-623	Wiring Diagram								X

② Circuit breakers listed are for units without electric heat."0Z" models. Hot gas bypass models not available without electric heat. See Heater Replacement Parts Manual for units with electric heat.
 NS = Not shown

This Table is references drawing on Page 7

**This page left blank
intentionally.**

CONTROL PANEL

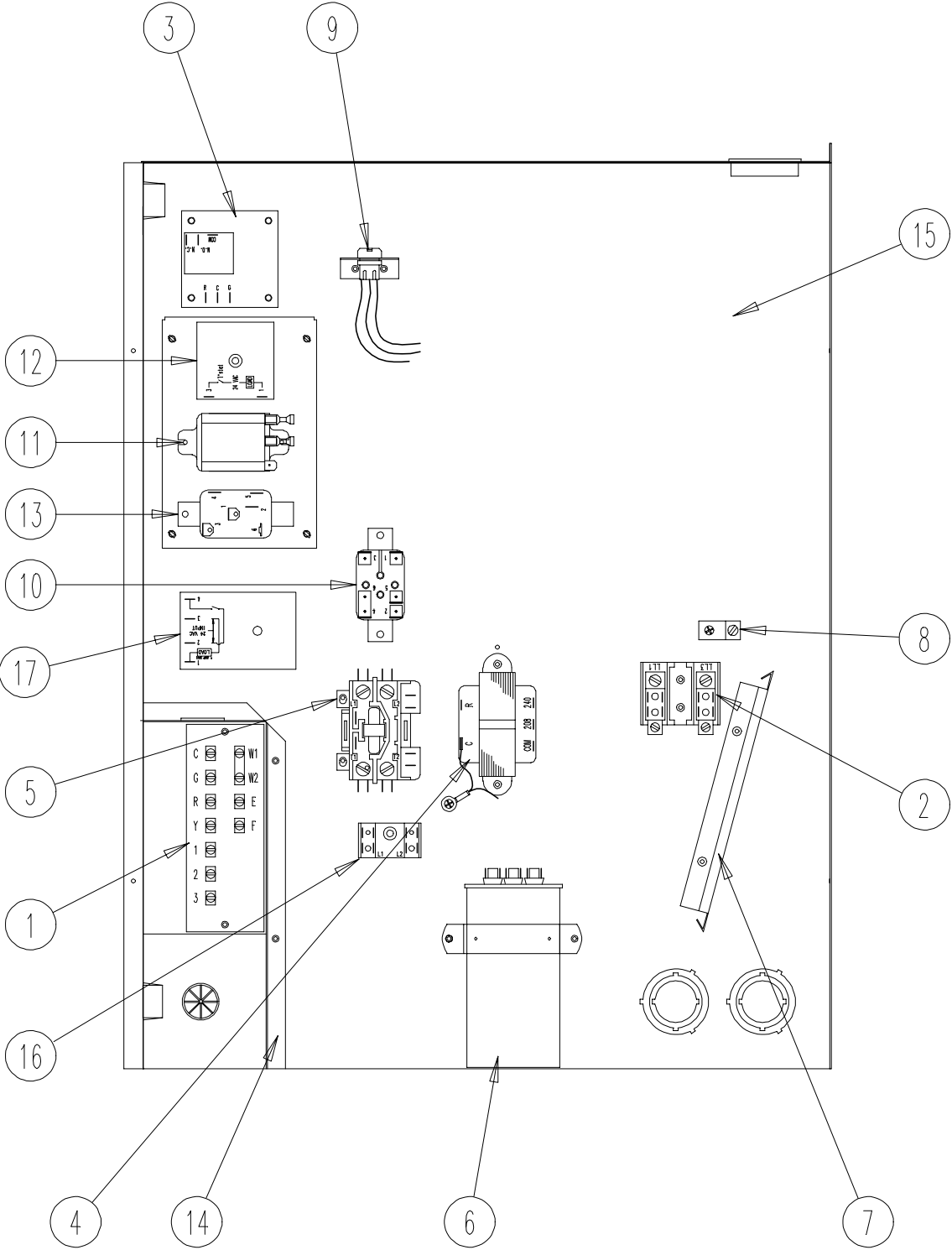

SEXP-326

CONTROL PANEL

Drawing			WA424DA	WA424DB	WA424DC	WA485DA	WA485DB	WA485DC	WA604DA	WA604DB	WA604DC
No.	Part No.	Description									
1	8607-020	Low Voltage Terminal Strip	X	X	X	X	X	X	X	X	X
2	8607-013	Terminal Block 2 Pole	X			X			X		
2	8607-014	Terminal Block 3 Pole		X	X		X	X		X	X
2	8607-015	Phenolic Insulator			X			X			X
3	8201-056	Blower Control	X	X		X	X		X	X	
3	8201-032	Blower Relay			X			X			X
4	8407-035	Transformer	X	X		X	X		X	X	
4	8407-042	Transformer			X			X			X
5	8401-002	Compressor Contactor		X	X		X	X		X	X
5	8401-016	Compressor Contactor				X			X		
5	5401-007	Compressor Contactor	X								
6	8552-005	Outdoor Motor Capacitor 10 MFD-370V		X			X			X	
6	8552-026	Outdoor Motor Capacitor 15 MFD-370V			X			X			X
6	8552-058	Compressor Capacitor 80/10 MFD-370V							X		
6	8552-072	Compressor Capacitor 50/10 MFD-370V				X					
6	8552-055	Compressor Capacitor 40/10 MFD-370V	X								
7	135-130	Wire Shield	X	X	X	X	X	X	X	X	X
8	8611-006	Ground Terminal	X	X	X	X	X	X	X	X	X
9	3000-978	6 Pin Connector	X	X	X	X	X	X	X	X	X
10	8201-034	Lockout Relay	X	X	X	X	X	X			
11	8201-071	Control Relay #1	X	X	X	X	X	X	X	X	X
12	8201-050	Compressor TDR 5 Min. Delay on Break	X	X	X	X	X	X	X	X	X
13	8201-062	Control Relay #2	X	X	X	X	X	X	X	X	X
14	117X139	Low Voltage Box	X	X	X	X	X	X	X	X	X
15	117X143	Control Panel	X	X	X	X	X	X	X	X	X
16	8607-017	Terminal Block (Optional)	X	X	X	X	X	X	X	X	X
17	8201-089	Time Delay Relay 10 Sec. Delay Off	X	X	X	X	X	X	X	X	X
NS	8615-040	Circuit Breaker 50 A 2 Pole ②	X			X					
NS	8615-042	Circuit Breaker 35 A 3 Pole ②		X			X				
NS	8615-053	Pull Disconnect ②			X			X			X
NS	8615-041	Circuit Breaker 60A 2 Pole ②							X		
NS	8615-044	Circuit Breaker 45A 3 Pole ②								X	
NS	4095-136	Wiring Diagram	X								
NS	4095-121	Wiring Diagram				X			X		
NS	4095-220	Wiring Diagram		X			X			X	
NS	4095-316	Wiring Diagram			X			X			X

② Circuit breakers listed are for units without electric heat."0Z" models. Hot gas bypass models not available without electric heat. See Heater Replacement Parts Manual for units with electric heat.

NS = Not shown

BLOWER ASSEMBLY

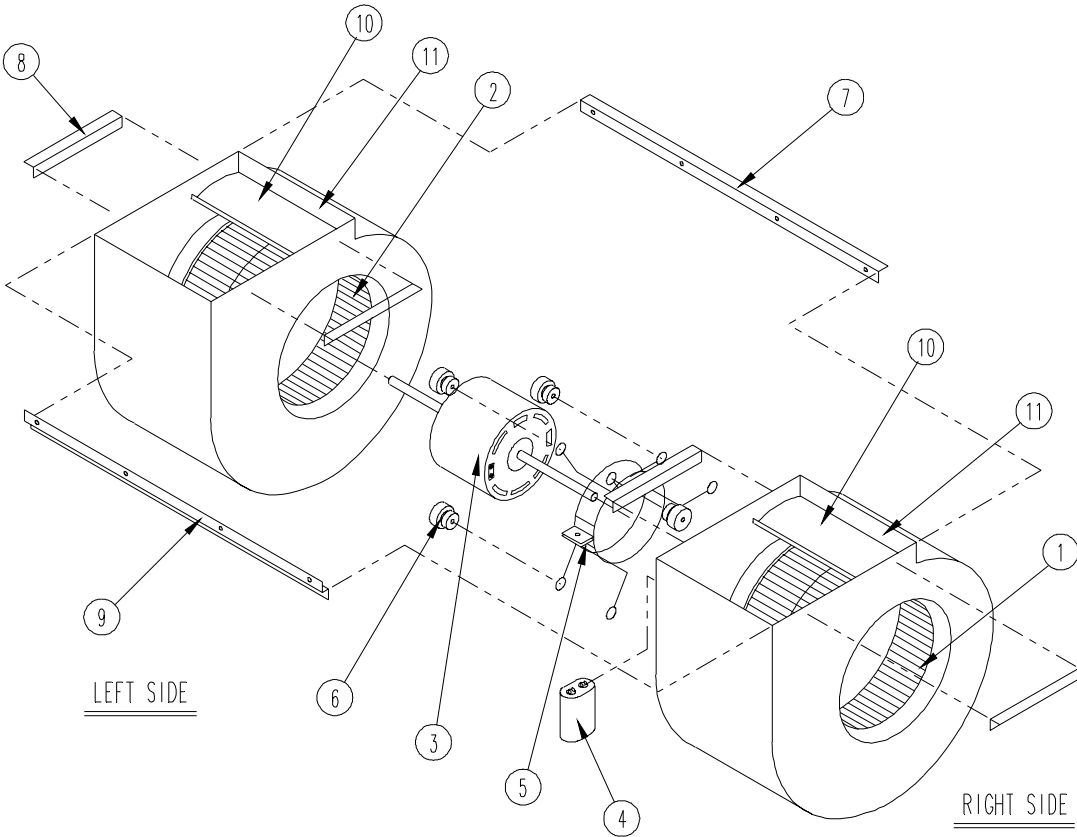

SEXP-178

Drawing No.	Part No.	Description	900-183	900-184	900-185	900-186	900-242	900-243
1	5152-011	10 Inch Wheel (CW)			X	X	X	X
1	5152-057	9 Inch Wheel (CW)	X	X				
2	5152-0212	10 Inch Wheel (CCW)			X	X	X	X
2	5152-058	9 Inch Wheel (CCW)	X	X				
3	8106-030	Blower Motor (230/208)	X		X			
3	8106-025	Blower Motor (460)		X		X		
3	8104-012	Blower Motor (230/208)					X	
3	8104-014	Blower Motor (460)						X
4	8552-005	Capacitor	X	X	X	X	X	X
5	8200-040	Motor Mount	X	X	X	X	X	X
6	5451-011	Grommets	6	6	6	6	6	6
7	105-881	Back Brace	X	X	X	X	X	X
8	105-880	Side Angle	4	4	4	4	4	4
9	103-389	Front Brace	X	X	X	X	X	X
10	151-101	Housing	2	2	2	2	2	2
11	144-166	Diffuser	2	2	2	2	2	2