

---

# REPLACEMENT PARTS MANUAL

# WALL MOUNTED PACKAGE AIR CONDITIONER

Models: **WL423**  
**WL484**  
**WL602**



## General Notes

- Revised and/or additional pages may be issued from time to time.
- A complete and current manual consists of pages shown in the following contents section.

## Important

- Contact the installing and/or local Bard distributor for all parts requirements. Make sure you have the complete model and serial number available from the unit rating plates.

## Contents

Description	Page
Cabinet Components	
♦ Exploded View .....	2
♦ Usage List .....	3
Functional Components	
♦ Exploded View .....	4
♦ Usage List .....	5
Control Panel	
♦ Exploded View .....	6
♦ Usage List .....	7
Blower Assembly	
♦ Exploded View .....	8
♦ Usage List .....	8



BARD MANUFACTURING COMPANY, INC.  
Bryan, Ohio 43506

*Since 1914...Moving ahead, just as planned.*

Manual: 2110-454B  
Supersedes: 2110-454A  
File: Tab 16  
Date: 07-10-06

# CABINET COMPONENTS

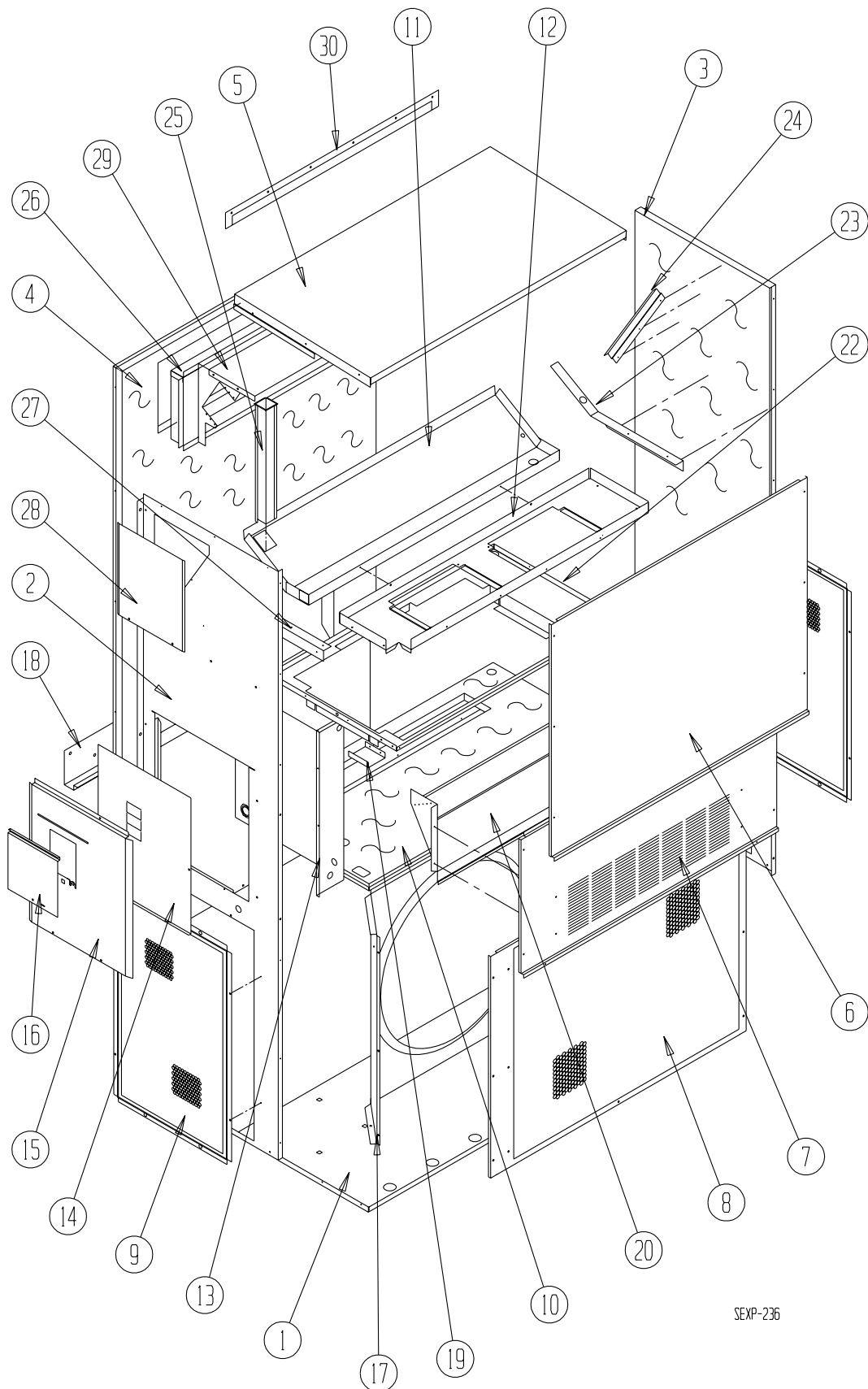

SEXP-236

# CABINET COMPONENTS

Drawing No.	Part No.	Description	WL423-A, B	WL423-C	WL484-A, B	WL484-C, -F	WL602-A, B	WL602-C, F
1	S127Y214	Lower Base	X	X	X	X	X	X
2	S500-319-* ①	Right Side	X	X	X	X	X	X
3	S500-320-* ①	Left Side	X	X	X	X	X	X
4	S508-098	Back	X	X	X	X	X	X
5	S506-142-* ①	Top	X	X	X	X	X	X
6	S514-077-* ①	Upper Front	X	X	X	X	X	X
7	S552-224-* ①	Service Door	X	X	X	X	X	X
8	118-049-* ①	Condenser Grille	X	X	X	X	X	X
9	118-057-* ①	Side Grille	2	2	2	2	2	2
10	S520Y258	Condenser Partition	X	X	X	X	X	X
11	123-091	Drain Pan	X	X	X	X	X	X
12	121Y216	Blower Partition	X	X	X	X	X	X
13	Control Panel Assembly	See Control Panel Assembly Drawing & Parts List	X	X	X	X	X	X
14	S133-114	Control Panel Cover (Inner)	X		X		X	
14	S133-171	Control Panel Cover (Inner)		X		X		X
15	S533-140-* ①	Control Panel Cover (Outer)	X	X	X	X	X	X
16	S153-218-* ①	Disconnect Access Door	X	X	X	X	X	X
17	125-024	Fan Shroud	X	X	X	X	X	X
18	113-140	Bottom Mounting Bracket	X	X	X	X	X	X
19	137-209	Fill	X	X	X	X	X	X
20	BFAD-5	Fresh Air Damper Assembly	X	X	X	X	X	X
22	131Y099	Filter Tray	X	X	X	X	X	X
23	105Y878	Left Side Support	X	X	X	X	X	X
24	147-046-* ①	Left Evaporator Support	X	X	X	X	X	X
25	135-128	Raceway	2	2	2	2	2	2
26	111Y034	Outlet Air Frame Assembly	X	X	X	X	X	X
27	105Y877	Right Side Support	X	X	X	X	X	X
28	S143-042-* ①	Right Side Cover Plate (Outer)	X	X	X	X	X	X
29	135-129	Heat Shield	X	X	X	X	X	X
30	113-150-* ①	Top Rain Flashing	X	X	X	X	X	X
NS	S536-498	Condenser Partition Block Off Plate	X	X	X	X	X	X

① Exterior cabinet parts are manufactured with various paint color options. To insure that you receive the proper paint color, you must include the complete model and serial number of the unit for which cabinet parts are being ordered.

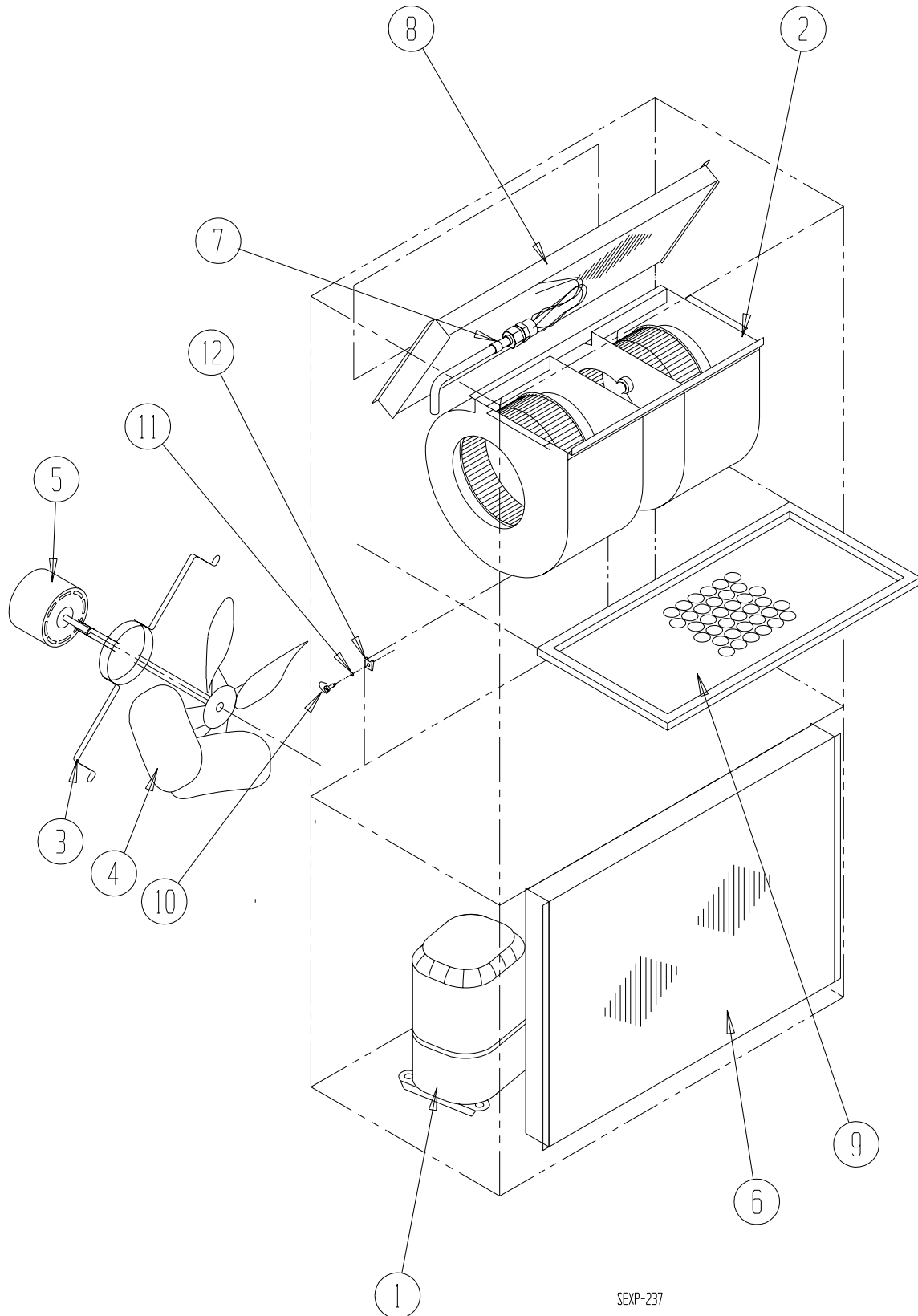

NS = Not Shown

# FUNCTIONAL COMPONENTS



SEXP-237

# FUNCTIONAL COMPONENTS

Drawing No.	Part No.	Description	WL423-A	WL423-B	WL423-C	WL484-A	WL484-B	WL484-C	WL602-A	WL602-B	WL602-C	WL602-F	WL484-F
1	8000-153	Compressor								X			
	8000-154	Compressor									X		
1	8000-155	Compressor										X	
1	8000-253	Compressor	X										
1	8000-205	Compressor		X									
1	8000-206	Compressor			X								
1	8000-236	Compressor				X							
1	8000-221	Compressor					X						
1	8000-222	Compressor						X					X
2	S900-183	Blower Assembly	X	X		X	X						X
2	S900-184	Blower Assembly			X			X					
2	S900-185	Blower Assembly							X	X		X	
2	S900-186	Blower Assembly									X		
3	8200-004	Fan Motor Mount	X	X	X	X	X	X	X	X	X	X	X
4	5151-027	Fan Blade	X	X	X	X	X	X	X	X	X	X	X
5	8105-030	Condenser Motor			X			X			X		
5	8105-039	Condenser Motor	X	X		X	X		X	X		X	X
6	5051-093BX	Condenser Coil				X	X	X	X	X	X	X	X
6	5051-094BX	Condenser Coil	X	X	X								
7	800-0204	Cooling Capillary Assembly				X	X	X					X
7	800-0318 	Cooling Capillary Assembly	X	X	X								
7	800-0234	Distributor Assembly							X	X	X	X	
8	5060-070BX	Evaporator Coil				X	X	X					X
8	5060-082BX	Evaporator Coil							X	X	X	X	
8	5060-113BX	Evaporator Coil	X	X	X								
9	7004-016	Air Filter 1" Throw-Away	X	X	X	X	X	X	X	X	X	X	X
9	7003-030	Air Filter 1" Washable	X	X	X	X	X	X	X	X	X	X	X
9	7004-027	Air Filter 2" Pleated	X	X	X	X	X	X	X	X	X	X	X
10	1171-022	1/4 Turn Fastener	X	X	X	X	X	X	X	X	X	X	X
11	1171-024	1/4 Turn Retainer	X	X	X	X	X	X	X	X	X	X	X
12	1171-023	1/4 Turn Receptacle	X	X	X	X	X	X	X	X	X	X	X
13	CMA-6	Low Ambient Control	X	X	X	X	X	X	X	X	X	X	X
NS	1804-0106	High Pressure Switch (Flare)	X	X	X	X	X	X	X	X	X	X	X
NS	1804-0107	Low Pressure Switch (Flare)	X	X	X	X	X	X	X	X	X	X	X

NS = Not Shown

# CONTROL PANEL

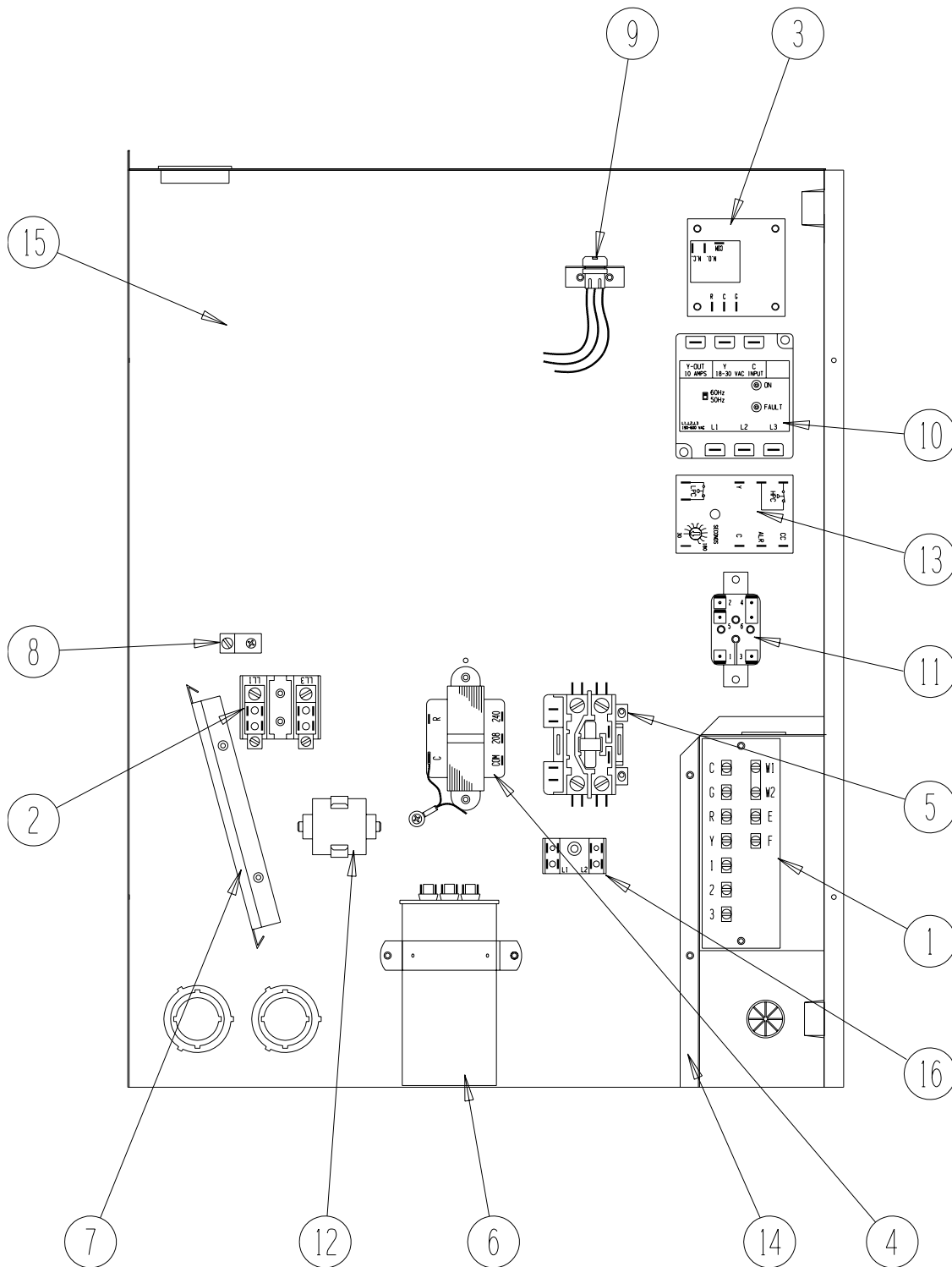

SEXP-324

# CONTROL PANEL

Drawing No.	Part No.	Description	WL423-A	WL423-B	WL423-C	WL484-A	WL484-B	WL484-C	WL602-A	WL602-B	WL602-C	WL602-F	WL484-F
1	8607-020	Low Voltage Terminal Strip	X	X	X	X	X	X	X	X	X	X	X
2	8607-013	Terminal Block 2 Pole	X			X			X			2	2
2	8607-014	Terminal Block 3 Pole		X	X		X	X		X	X		
2	8607-015	Phenolic Insulator			X			X			X		
3	8201-056	Blower Control	X	X		X	X		X	X		X	X
3	8201-032	Blower Relay			X			X			X		
4	8407-034	Transformer	X	X		X	X		X	X		X	X
4	8407-042	Transformer			X			X			X		
5	8401-002	Compressor Contactor		X	X		X	X		X	X	X	X
5	8401-025	Compressor Contactor	X			X			X				
6	8552-005	Outdoor Motor Capacitor		X			X			X		X	X
6	8552-026	Outdoor Motor Capacitor			X			X			X		
6	8552-055	Compressor Capacitor	X										
6	8552-058	Compressor Capacitor							X				
6	8552-072	Compressor Capacitor				X							
7	135-130	Wire Shield	X	X	X	X	X	X	X	X	X	X	X
8	8611-006	Ground Terminal	X	X	X	X	X	X	X	X	X	X	X
9	3000-978	6 Pin Connector	X	X	X	X	X	X	X	X	X	X	X
10	8201-085	Phase Monitor		X	X		X	X		X	X	X	X
11	8201-062	Alarm Relay (Optional)	X	X	X	X	X	X	X	X	X	X	X
12	8551-005	Start Device (PTRC) (Optional)	X			X			X				
13	8201-088	Compressor Control Module	X	X	X	X	X	X	X	X	X	X	X
14	117-139	Low Voltage Box	X	X	X	X	X	X	X	X	X	X	X
15	117-143	Control Panel	X	X	X	X	X	X	X	X	X	X	X
16	8607-017	Terminal Block (Optional)	X	X	X	X	X	X	X	X	X	X	X
NS	4095-137	Wiring Diagram	X										
NS	4095-128	Wiring Diagram				X			X				
NS	4095-234	Wiring Diagram		X									
NS	4095-227	Wiring Diagram					X			X			
NS	4095-321	Wiring Diagram			X								
NS	4095-318	Wiring Diagram						X			X		
NS	4095-623	Wiring Diagram										X	
NS	4095-631	Wiring Diagram											X

NS = Not Shown

# BLOWER ASSEMBLY

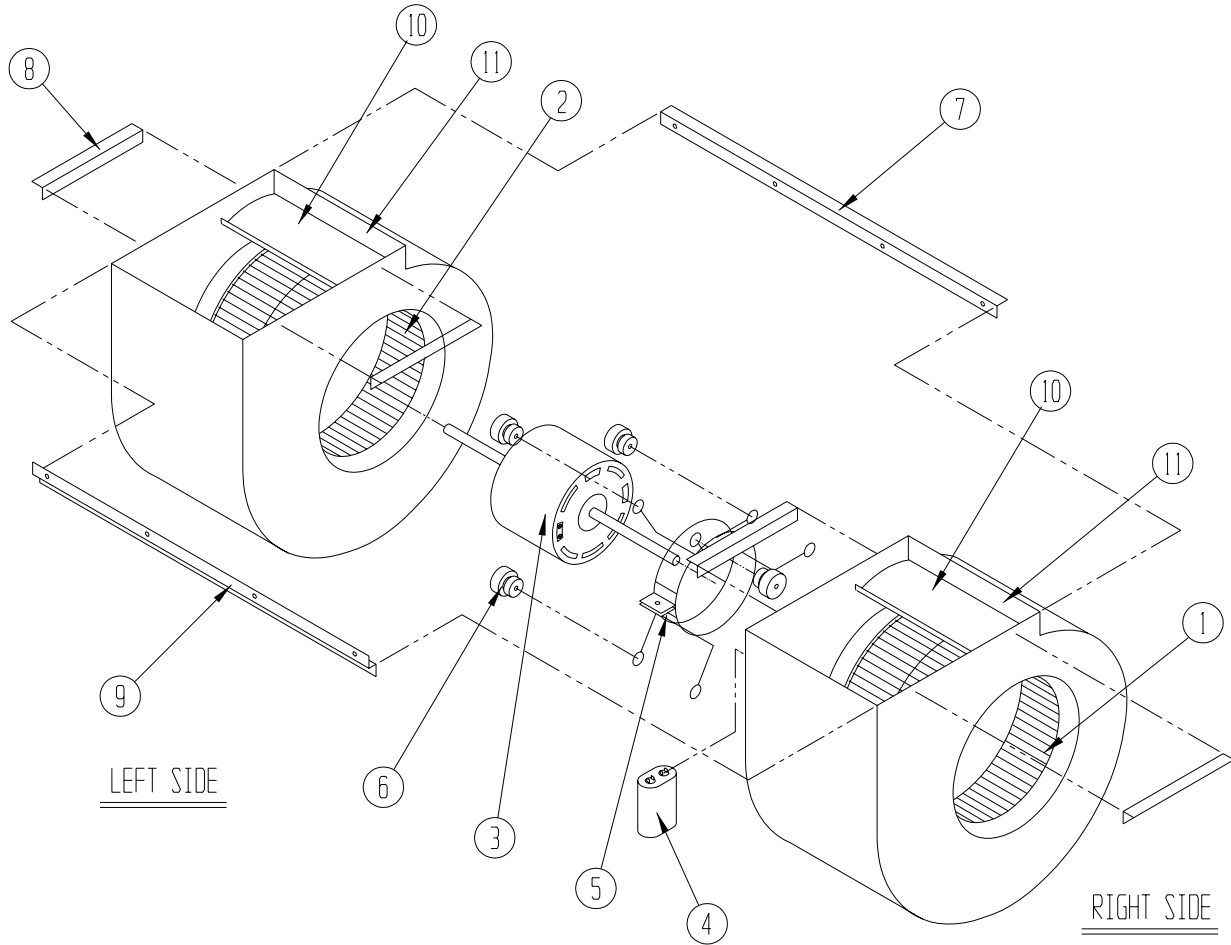

SEXP-178

Drawing No.	Part No.	Description	900-183	900-184	900-185	900-186
1	5152-011	10 Inch Wheel (CW)			X	X
1	5152-057	9 Inch Wheel (CW)	X	X		
2	5152-012	10 Inch Wheel (CCW)			X	X
2	5152-058	9 Inch Wheel (CCW)	X	X		
3	8106-030	Blower Motor (230/208)	X		X	
3	8106-025	Blower Motor (460)		X		X
4	8552-005	Capacitor	X	X	X	X
5	8200-040	Motor Mount	X	X	X	X
6	5451-011	Grommets	6	6	6	6
7	105-881	Back Brace	X	X	X	X
8	105-880	Side Angle	4	4	4	4
9	103-389	Front Brace	X	X	X	X
10	151-101	Housing	2	2	2	2
11	144-166	Diffuser	2	2	2	2